



PSA PASSIVE SYSTEM ALLIANCE
WALSIN TECHNOLOGY CORPORATION

Metal Oxide Varistor

www.passivecomponent.com



Product Portfolio



IEC-63 Nominal Resistance/ Capacitance

E1	100																							
E3	100				220				470															
E6	100	150	220	330	470	680																		
E12	100	120	150	180	220	270	330	390	470	560	680	820												
E24	100	110	120	130	150	160	180	200	220	240	270	300	330	360	390	430	470	510	560	620	680	750	820	910
E96	100	102	121	124	147	150	178	182	215	221	261	267	316	324	383	392	464	475	562	576	681	698	825	845
	105	107	127	130	154	158	187	191	226	232	274	280	332	340	402	412	487	499	590	604	715	732	866	887
	110	113	133	137	162	165	196	200	237	243	287	294	348	357	422	432	511	523	619	634	750	768	909	931
	115	118	140	143	169	174	205	210	249	255	301	309	365	374	442	453	536	549	649	665	787	806	953	976

E6: $\sqrt[6]{10} \approx 1.46$ E12: $\sqrt[12]{10} \approx 1.21$
 E1 series resistance: 1Ω, 10Ω, 100Ω, 1000Ω, 10000Ω, 100000Ω

INDEX

Subject	Page
Varistors-5D Series	3
Varistors-7D Series	4
Varistors-10D Series	5
Varistors-14D Series	6
Varistors-20D Series	7
Varistors-25D Series	8
Varistors-5E 、 7E Series	9
Varistors-10E 、 14E Series	10
Varistors-18E 、 20E Series	11
V-I Curve	12
Packing Specification (5Ø - 25Ø Series)	15
Taping Specifications - 5Ø and 7Ø	16
Taping Specifications - 10Ø and 14Ø	17
Taping Specifications - 18Ø and 20Ø	18
Big Size Varistor - 32D Series	19
Big Size Varistor - 34mm Single Series	20
Big Size Varistor - 34mm Dual Series	21
Big Size Varistor - 40D Series	22
Big Size Varistor - 53D Series	23
Packing of Big MOV and Soldering Profile of MOV.....	25

*The specifications are subject to change or our products in it may be discontinued without advance notice. Please check with our sales representatives or product engineers before ordering.

*This catalog has only typical specifications because there is no space for detailed specifications. Therefore, please approve our product specifications or transact the approval sheet for product specification before ordering.

■ **HOW TO ORDER**

SR	241	K	10	D	S	20C	N	E	E	N
Type Code	Varistor Voltage	Tolerance	Disk Size code	Disk type	Lead style	Lead Cutting & Taping Code	Lead space+Tol. (mm)	Lead Material (mm)	Coating	Special code
SR: Walsin Varistor	(DC volt) (From 180 to 112) Two significant digits Followed by no. of zeros 180=18volt 101=100volt 102=1000volt	K :±10%	05:5mm 07:7mm 10:10mm 14:14mm 18:18mm 20:20mm 25:25mm	D:Standard E:High Energy	S: Straight Lead L: Inline Crimped O: Outward Crimped I: Inward Crimped	Taping AMD:P=25.4mm, Ammo TMD:P=25.4mm, Reel Please refer: Taping Specifications Bulk 20C:20mm Min 3EA:3.5±0.5mm 05A:5.0±0.5mm 3EB:3.5±1.0mm 05B:5.0±1.0mm	5:5.0±0.5 E:5.0±0.8 F:5.0±1.0 7:7.5±0.5 M:7.5±0.8 N:7.5±1.0 R:10.0±0.5 0:10.0±1.0 T:10.0±0.8	D:0.6 CP wire E:0.8 CP wire F:1.0 CP wire	E:Epoxy coating	N:N/A

■ **DIMENSIONS QUICK REFERENCE** :If specific item's dimensions, please contact sales

Series	5D,5E	7D,7E	10D,10E	14D,14E	18E	20D,20E	25D
Dmax	7.0	9.0	12.0	16.5	20.0	22.5	28.0
d*	0.6	0.6	0.8	0.8	0.8	1.0	1.0
W**	5.0	5.0	7.5	7.5	7.5	10.0	12.7
Hmax	12.5	14.5	19.0	22.5	26.0	29.0	36.5
H1max	10.0	12.0	17.0	20.5	24.0	28.0	34.0
Tmax	4.9	4.9	8.5	8.5	9.0	9.0	9.5

* ±0.05 ** ±1.0

(Unit: mm)

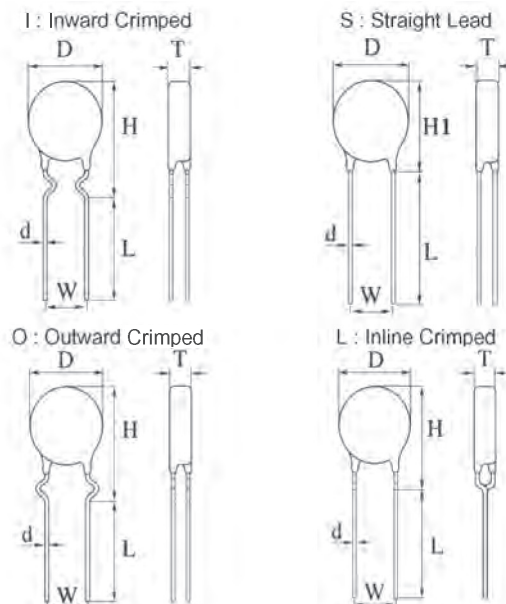

Remark:
The lead length (L) is 20mm minimum unless requested by customers; please refer to lead cutting code in "How to Order".

CHARACTERISTICS

- High performance transient voltage suppression
- Short response time to surge voltage
- Low standby power dissipation
- Excellent clamping characteristics
- High performance withstanding surge currents
- High reliability
- UL, cUL, VDE and CQC recognized

DEFINITION OF VARISTOR TERMS

Rated RMS Voltage, Rated DC Voltage :

The maximum designated values of power system voltage that may be applied continuously between the terminals of a device.

Varistor Voltage :

Test characteristic that is used to classify varistors by type. A test current of 1mA DC is typically used to determine varistor voltage classification type. Varistor voltage clamping characteristics can be defined at various test levels.

Rated Peak Single Pulse Transient Current :

Maximum surge current, 8/20 μ s waveform which a varistor is rated to withstand for a single surge.

Rated Single Pulse Transient Energy :

Maximum allowable energy for a single impulse (see specified waveforms).

Maximum Clamping Voltage :

Measured peak voltage across the device terminals when a current impulse of specified amplitude and waveform is conducted through the varistor.

Typical Capacitance :

Typical capacitance values are measured at a test frequency of 1kHz. Capacitance values are only for reference purpose only, not subject to outgoing inspection.

APPLICATIONS

- Surge protection in:
 - Consumer electronics
 - Industrial electronics
 - Communication electronics
 - Measuring and controlling systems
 - Electronic home appliances
- Protection against surges induced by lightning striking incoming power lines.
- Suppression of surges caused by switching inductive loads such as transformers, relays and coils.
- Protection of rectification diodes, SCRs, power transistors, semiconductor devices, etc

GENERAL CHARACTERISTICS

Storage Temperature : -40°C to +125°C

Operating Ambient Temperature : -40°C to +85°C (without derating)

Maximum Voltage-Temperature Coefficient : < -0.05% / °C

Insulation Resistance : 1000 Mega-ohm minimum

Hi Pot (Leads To Case, 1 Min.) : 2500 VDC

Typical Response Time : <25 Nano-seconds

Epoxy Rating : 94V-0

Current / Energy Derating (>85°C) : -2.5% / °C

DC Leakage Current : 200 μ A maximum (at rated DC working voltage)

Solderability : MIL-STD-202F

Power Dissipation Ratings(P, in-watts) :

Disc Size	11Vac~40Vac	50Vac~680Vac
5mm	0.01	0.15
7mm	0.02	0.25
10mm	0.05	0.4
14mm	0.1	0.6
18mm	--	0.8
20mm	0.2	1.0
25mm	--	1.2
32mm	--	1.6
34mm(single)	--	2.1
34mm(dual)	--	2.73
40mm	--	2.1
53mm	--	2.5

All definitions are according to IEEE specifications C62.33.

ENERGY DERATING VERSUS TEMPERATURE

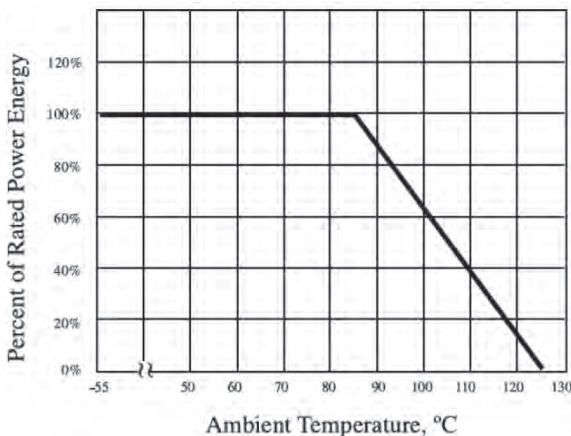

PEAK CURRENT PER PULSE VERSUS PULSE DURATION

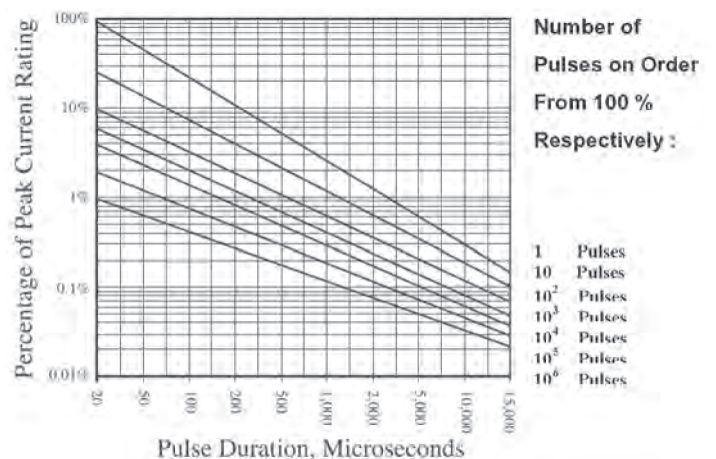

Type Number	Maximum Allowable Voltage		Varistor Voltage		Withstanding Surge Current (8/20 μs)		Max. Clamping Voltage (8/20 μs)		Maximum Energy		Typical Capacitance	Safety Approval	
	Acrms	DC	DC Volts		1 time	2 times	Vc	Ip	2ms	10/1000μs	@1kHz		
	Volts	Volts	Min	Max	Amps		Volts	Amps	Joules		pF		
SR180K05D	11	14	16	20	100	50	36	1	0.4	0.6	1500	△	☆
SR220K05D	14	18	20	24	100	50	43	1	0.6	0.8	1260	△	☆
SR270K05D	17	22	24	30	100	50	53	1	0.7	0.9	1050	△	☆
SR330K05D	20	26	30	36	100	50	65	1	0.9	1.2	850	△	☆
SR390K05D	25	31	35	43	100	50	77	1	1.1	1.3	600	△	☆
SR470K05D	30	38	42	52	100	50	93	1	1.4	1.6	500	△	☆
SR560K05D	35	45	50	62	100	50	110	1	1.5	1.9	400	△	☆
SR680K05D	40	56	61	75	100	50	135	1	1.8	2.3	360	△	☆
SR820K05D	50	66	74	90	400	200	135	5	2.4	3.0	350	△	☆
SR101K05D	60	85	90	110	400	200	165	5	2.4	3.5	320	△	☆
SR121K05D	75	102	108	132	400	200	200	5	3.0	5.0	250	△	☆
SR151K05D	95	127	135	165	400	200	250	5	3.5	5.5	180	△	☆
SR181K05D	120	160	170	207	400	200	320	5	4.2	8.0	155	△	☆
SR201K05D	130	175	185	225	400	200	340	5	5.0	8.5	140	△	☆
SR221K05D	140	180	198	242	400	200	360	5	6.0	9.0	125	△	☆
SR241K05D	150	200	216	264	400	200	395	5	6.5	10.0	115	△	☆
SR271K05D	180	230	255	311	400	200	475	5	7.5	11.0	105	△	☆
SR301K05D	195	250	270	330	400	200	525	5	8.0	11.5	95	△	☆
SR331K05D	210	275	297	363	400	200	540	5	8.5	11.7	85	△	☆
SR361K05D	230	300	324	396	400	200	595	5	9.0	13.0	80	△	☆
SR391K05D	250	330	351	429	400	200	650	5	10	15	75	△	☆
SR431K05D	275	370	387	473	400	200	710	5	11	16	65	△	☆
SR471K05D	300	385	423	517	400	200	775	5	13	19	55	△	☆
SR511K05D	320	420	459	561	400	200	865	5	15	21	39	△	☆
SR561K05D	360	470	522	638	400	200	960	5	17	25	36	△	☆
SR621K05D	390	505	558	682	400	200	1040	5	19	27	33	△	☆
SR681K05D	420	560	612	748	400	200	1120	5	21	30	30	△	☆

Remark:

1. Please refer "How to Order" for details
2. All parts approved as follows:
 - (1) △: **UL 1449** recognized (File # E309297).
 - (2) ☆: **cUL** (CSA 22.2 #1 certified, File # E309297).
 - (3) **CQC** recognized for all part numbers (CQC04001010926)

Type Number	Maximum Allowable Voltage		Varistor Voltage		Withstanding Surge Current (8/20 μs)		Max. Clamping Voltage (8/20 μs)		Maximum Energy		Typical Capacitance	Safety Approval	
	Acrms	DC	DC Volts		1 time	2 times	Vc	Ip	2ms	10/1000μs	@1kHz		
	Volts	Volts	Min	Max	Amps		Volts	Amps	Joules		pF		
SR180K07D	11	14	16	20	250	125	36	2.5	0.8	1	2900	△	☆◇
SR220K07D	14	18	20	24	250	125	43	2.5	0.9	1.3	2400	△	☆◇
SR270K07D	17	22	24	30	250	125	53	2.5	1	1.4	1800	△	☆◇
SR330K07D	20	26	30	36	250	125	65	2.5	1.2	1.7	1500	△	☆◇
SR390K07D	25	31	35	43	250	125	77	2.5	1.5	2.1	1230	△	☆◇
SR470K07D	30	38	42	52	250	125	93	2.5	1.8	2.5	950	△	☆◇
SR560K07D	35	45	50	62	250	125	110	2.5	2.2	3.1	890	△	☆◇
SR680K07D	40	56	61	75	250	125	135	2.5	2.5	3.8	850	△	☆◇
SR820K07D	50	66	74	90	1200	600	135	10	3.5	5.5	830	△	☆◇
SR101K07D	60	85	90	110	1200	600	165	10	4	6.5	730	△	☆◇
SR121K07D	75	102	108	132	1200	600	200	10	5	7.8	570	△	☆◇
SR151K07D	95	127	135	165	1200	600	250	10	6.5	9.7	400	△	☆◇
SR181K07D	120	160	170	207	1200	600	300	10	8.8	12	305	△	☆◇
SR201K07D	130	175	185	225	1200	600	340	10	10	13	275	△	☆◇
SR221K07D	140	180	198	242	1200	600	360	10	11	14	250	△	☆◇
SR241K07D	150	200	216	264	1200	600	395	10	11	16	230	△	☆◇
SR271K07D	180	230	255	311	1200	600	455	10	12	18	205	△	☆◇
SR301K07D	195	250	270	330	1200	600	505	10	13	19	185	△	☆◇
SR331K07D	210	275	297	363	1200	600	540	10	14	20	170	△	☆◇
SR361K07D	230	300	324	396	1200	600	595	10	15	25	155	△	☆◇
SR391K07D	250	330	351	429	1200	600	650	10	17	26	145	△	☆◇
SR431K07D	275	370	387	473	1200	600	710	10	20	28	130	△	☆◇
SR471K07D	300	385	423	517	1200	600	775	10	21	30	115	△	☆◇
SR511K07D	320	420	459	561	1200	600	850	10	23	32	88	△	☆◇
SR561K07D	360	470	522	638	1200	600	960	10	27	39	85	△	☆◇
SR621K07D	390	505	558	682	1200	600	1040	10	29	43	82	△	☆◇
SR681K07D	420	560	612	748	1200	600	1120	10	32	45	78	△	☆◇

Remark:

1. Please refer "How to Order" for details
2. All parts approved as follows:
 - (1) △: **UL 1449** recognized (File # E309297).
 - (2) ☆: **cUL** (CSA 22.2 #1 certified, File # E309297).
 - (3) ◇: **VDE/CECC 42000/42200/42201**, IEC 61051-1/61051-2/61051-2- (Certificate # 40010090)
 - (4) **CQC** recognized for all part numbers (CQC04001010927)

Type Number	Maximum Allowable Voltage		Varistor Voltage		Withstanding Surge Current (8/20 μ s)		Max. Clamping Voltage (8/20 μ s)		Maximum Energy		Typical Capacitance	Safety Approval
	Acrms	DC	DC Volts		1 time	2 times	Vc	Ip	2ms	10/1000 μ s	@1kHz	
	Volts	Volts	Min	Max	Amps		Volts	Amps	Joules		pF	
SR180K10D	11	14	16	20	500	250	36	5	1.5	2.1	6000	△ ☆ ◇
SR220K10D	14	18	20	24	500	250	43	5	2	2.5	5000	△ ☆ ◇
SR270K10D	17	22	24	30	500	250	53	5	2.5	3	4000	△ ☆ ◇
SR330K10D	20	26	30	36	500	250	65	5	3	4	3500	△ ☆ ◇
SR390K10D	25	31	35	43	500	250	77	5	3.5	4.6	3100	△ ☆ ◇
SR470K10D	30	38	42	52	500	250	93	5	4.5	5.5	2800	△ ☆ ◇
SR560K10D	35	45	50	62	500	250	110	5	5.5	7	2400	△ ☆ ◇
SR680K10D	40	56	61	75	500	250	135	5	6.5	8.2	2100	△ ☆ ◇
SR820K10D	50	66	74	90	2500	1250	135	25	8	12	1600	△ ☆ ◇
SR101K10D	60	85	90	110	2500	1250	165	25	10	15	1400	△ ☆ ◇
SR121K10D	75	102	108	132	2500	1250	200	25	12	18	1200	△ ☆ ◇
SR151K10D	95	127	135	165	2500	1250	250	25	16	22	1100	△ ☆ ◇
SR181K10D	120	160	170	207	2500	1250	300	25	18.5	27.5	700	△ ☆ ◇
SR201K10D	130	175	185	225	2500	1250	340	25	20	30	640	△ ☆ ◇
SR221K10D	140	180	198	242	2500	1250	360	25	23	32	600	△ ☆ ◇
SR241K10D	150	200	216	264	2500	1250	395	25	25	35	560	△ ☆ ◇
SR271K10D	180	230	255	311	2500	1250	455	25	30	40	500	△ ☆ ◇
SR301K10D	195	250	270	330	2500	1250	505	25	32	42.5	450	△ ☆ ◇
SR331K10D	210	275	297	363	2500	1250	540	25	33.5	44.5	415	△ ☆ ◇
SR361K10D	230	300	324	396	2500	1250	595	25	35	47	380	△ ☆ ◇
SR391K10D	250	330	351	429	2500	1250	650	25	40	60	350	△ ☆ ◇
SR431K10D	275	370	387	473	2500	1250	710	25	45	65	310	△ ☆ ◇
SR471K10D	300	385	423	517	2500	1250	775	25	46	70	280	△ ☆ ◇
SR511K10D	320	420	459	561	2500	1250	840	25	47	71	260	△ ☆ ◇
SR561K10D	360	470	522	638	2500	1250	910	25	48	72	240	△ ☆ ◇
SR621K10D	390	505	558	682	2500	1250	1025	25	49	73	150	△ ☆ ◇
SR681K10D	420	560	612	748	2500	1250	1120	25	50	74	130	△ ☆ ◇
SR751K10D	460	615	675	825	2500	1250	1240	25	51	75	120	△ ☆ ◇
SR781K10D	485	640	702	858	2500	1250	1290	25	52	80	120	△ ☆ ◇
SR821K10D	510	675	738	902	2500	1250	1350	25	55	85	110	△ ☆ ◇
SR911K10D	550	745	819	1001	2500	1250	1400	25	60	93	90	△ ☆ ◇
SR102K10D	625	825	900	1100	2500	1250	1620	25	65	102	80	△ ☆ ◇
SR112K10D	680	895	962	1175	2500	1250	1800	25	70	115	70	△ ☆ ◇

Remark:

1. Please refer "How to Order" for details
2. All parts approved as follows:
 - (1) △: **UL 1449** recognized (File # E309297).
 - (2) ☆: **cUL** (CSA 22.2 #1 certified, File # E309297).
 - (3) ◇: **VDE/CECC 42000/42200/42201**, IEC 61051-1/61051-2/61051-2-2 (Certificate # 40010090)
 - (4) **CQC** recognized for all part numbers (CQC04001010928)

Type Number	Maximum Allowable Voltage		Varistor Voltage		Withstanding Surge Current (8/20 μs)		Max. Clamping Voltage (8/20 μs)		Maximum Energy		Typical Capacitance	Safety Approval
	Acrms	DC	DC Volts		1 time	2 times	Vc	Ip	2ms	10/1000μs	@1kHz	
	Volts	Volts	Min	Max	Amps		Volts	Amps	Joules		pF	
SR180K14D	11	14	16	20	1000	500	36	10	3.5	4	15000	△ ☆ ◇ #
SR220K14D	14	18	20	24	1000	500	43	10	4	5	12000	△ ☆ ◇ #
SR270K14D	17	22	24	30	1000	500	53	10	5	6	8500	△ ☆ ◇ #
SR330K14D	20	26	30	36	1000	500	65	10	6	7.5	7200	△ ☆ ◇ #
SR390K14D	25	31	35	43	1000	500	77	10	7	8.6	6300	△ ☆ ◇ #
SR470K14D	30	38	42	52	1000	500	93	10	8.5	10	5500	△ ☆ ◇ #
SR560K14D	35	45	50	62	1000	500	110	10	10	11	4800	△ ☆ ◇ #
SR680K14D	40	56	61	75	1000	500	135	10	12	14	4000	△ ☆ ◇ #
SR820K14D	50	66	74	90	4500	2500	135	50	15	22	3300	△ ☆ ◇ #
SR101K14D	60	85	90	110	4500	2500	165	50	20	30	2900	△ ☆ ◇ #
SR121K14D	75	102	108	132	4500	2500	200	50	22	34	2600	△ ☆ ◇ #
SR151K14D	95	127	135	165	4500	2500	250	50	30	45	2000	△ ☆ ◇ #
SR181K14D	120	160	170	207	4500	2500	300	50	33	53	1400	△ ☆ ◇ #
SR201K14D	130	175	185	225	4500	2500	340	50	38	60	1370	△ ☆ ◇ #
SR221K14D	140	180	198	242	4500	2500	360	50	40	60	1150	△ ☆ ◇ #
SR241K14D	150	200	216	264	4500	2500	395	50	45	66	1060	△ ☆ ◇ #
SR271K14D	180	230	255	311	4500	2500	455	50	52	72	950	△ ☆ ◇ #
SR301K14D	195	250	270	330	4500	2500	505	50	56	78	890	△ ☆ ◇ #
SR331K14D	210	275	297	363	4500	2500	545	50	63	87	800	△ ☆ ◇ #
SR361K14D	230	300	324	396	4500	2500	595	50	70	98	725	△ ☆ ◇ #
SR391K14D	250	330	351	429	4500	2500	650	50	72	102	665	△ ☆ ◇ #
SR431K14D	275	370	387	473	4500	2500	710	50	75	115	600	△ ☆ ◇ #
SR471K14D	300	385	423	517	4500	2500	775	50	80	125	570	△ ☆ ◇ #
SR511K14D	320	420	459	561	4500	2500	840	50	82	128	530	△ ☆ ◇ #
SR561K14D	360	470	522	638	4500	2500	910	50	85	139	480	△ ☆ ◇ #
SR621K14D	390	505	558	682	4500	2500	1025	50	88	142	270	△ ☆ ◇ #
SR681K14D	420	560	612	748	4500	2500	1120	50	90	142	240	△ ☆ ◇ #
SR751K14D	460	615	675	825	4500	2500	1240	50	100	143	210	△ ☆ ◇ #
SR781K14D	485	640	702	858	4500	2500	1290	50	105	148	205	△ ☆ ◇ #
SR821K14D	510	675	738	902	4500	2500	1350	50	110	157	200	△ ☆ ◇ #
SR911K14D	550	745	819	1001	4500	2500	1400	50	120	175	175	△ ☆ ◇ #
SR102K14D	625	825	900	1100	4500	2500	1620	50	130	190	145	△ ☆ ◇ #
SR112K14D	680	895	962	1175	4500	2500	1800	50	140	215	140	△ ☆ ◇ #

Remark:

1. Please refer "How to Order" for details
2. All parts approved as follows:
 - (1) △: **UL 1449** recognized (File # E309297).
 - (2) ☆: **cUL** (CSA 22.2 #1 certified, File # E309297).
 - (3) ◇: **VDE/CECC 42000/42200/42201**, IEC 61051-1/61051-2/61051-2-2 (Certificate # 40010090)
 - (4) #: **VDE/IEC 60950-1,Annex Q** (Certificate # 40010090)
 - (5) **CQC** recognized for all part numbers (CQC04001010929)

Type Number	Maximum Allowable Voltage		Varistor Voltage		Withstanding Surge Current (8/20 μ s)		Max. Clamping Voltage (8/20 μ s)		Maximum Energy		Typical Capacitance	Safety Approval
	Acrms	DC	DC Volts		1 time	2 times	Vc	Ip	2ms	10/1000 μ s	@1kHz	
	Volts	Volts	Min	Max	Amps		Volts	Amps	Joules		pF	
SR390K20D	25	31	35	43	2000	1000	77	20	24	26	10000	△ ☆ ◇
SR470K20D	30	38	42	52	2000	1000	93	20	30	33	9350	△ ☆ ◇
SR560K20D	35	45	50	62	2000	1000	110	20	35	38	8000	△ ☆ ◇
SR680K20D	40	56	61	75	2000	1000	135	20	40	43	6800	△ ☆ ◇
SR820K20D	50	66	74	90	6500	4000	135	100	37	48	5600	△ ☆ ◇
SR101K20D	60	85	90	110	6500	4000	165	100	38	50	4700	△ ☆ ◇
SR121K20D	75	102	108	132	6500	4000	200	100	40	55	4100	△ ☆ ◇
SR151K20D	95	127	135	165	6500	4000	250	100	50	70	3200	△ ☆ ◇
SR181K20D	120	160	170	207	6500	4000	300	100	60	85	2500	△ ☆ ◇
SR201K20D	130	175	185	225	6500	4000	340	100	70	95	2200	△ ☆ ◇
SR221K20D	140	180	198	242	6500	4000	360	100	75	100	2000	△ ☆ ◇
SR241K20D	150	200	216	264	6500	4000	395	100	82	110	1900	△ ☆ ◇
SR271K20D	180	230	255	311	6500	4000	455	100	90	127	1700	△ ☆ ◇
SR301K20D	195	250	270	330	6500	4000	505	100	100	135	1540	△ ☆ ◇
SR331K20D	210	275	297	363	6500	4000	540	100	110	148	1400	△ ☆ ◇
SR361K20D	230	300	324	396	6500	4000	595	100	120	163	1320	△ ☆ ◇
SR391K20D	250	330	351	429	6500	4000	650	100	130	180	1210	△ ☆ ◇
SR431K20D	275	370	387	473	6500	4000	710	100	140	190	1120	△ ☆ ◇
SR471K20D	300	385	423	517	6500	4000	775	100	150	220	1000	△ ☆ ◇
SR511K20D	320	420	459	561	6500	4000	840	100	152	222	950	△ ☆ ◇
SR561K20D	360	470	522	638	6500	4000	910	100	154	226	900	△ ☆ ◇
SR621K20D	390	505	558	682	6500	4000	1025	100	158	228	770	△ ☆ ◇
SR681K20D	420	560	612	748	6500	4000	1120	100	160	230	700	△ ☆ ◇
SR751K20D	460	615	675	825	6500	4000	1240	100	175	255	640	△ ☆ ◇
SR781K20D	485	640	702	858	6500	4000	1290	100	180	265	590	△ ☆ ◇
SR821K20D	510	675	738	902	6500	4000	1350	100	190	282	510	△ ☆ ◇
SR911K20D	550	745	819	1001	6500	4000	1400	100	215	310	430	△ ☆ ◇
SR102K20D	625	825	900	1100	6500	4000	1620	100	230	342	380	△ ☆ ◇
SR112K20D	680	895	962	1175	6500	4000	1800	100	250	383	340	△ ☆ ◇

Remark:

1. Please refer "How to Order" for details
2. All parts approved as follows:
 - (1) △: **UL 1449** recognized (File # E309297).
 - (2) ☆: **cUL** (CSA 22.2 #1 certified, File # E309297).
 - (3) ◇: **VDE/CECC 42000/42200/42201**, IEC 61051-1/61051-2/61051-2-2 (Certificate # 40010090)
 - (4) **CQC** recognized for all part numbers (CQC04001010931)

Type Number	Maximum Allowable Voltage		Varistor Voltage		Withstanding Surge Current (8/20 μ s)		Max. Clamping Voltage (8/20 μ s)		Maximum Energy		Typical Capacitance	Safety Approval
	Acrms	DC	DC Volts		1 time	2 times	Vc	Ip	2ms	10/1000 μ s	@1kHz	
	Volts	Volts	Min	Max	Amps		Volts	Amps	Joules		pF	
SR181K25D	120	160	170	207	18000	12000	300	100	90	180	3900	△ ☆
SR201K25D	130	175	185	225	18000	12000	340	100	100	200	3600	△ ☆
SR221K25D	140	180	198	242	18000	12000	360	100	105	225	3300	△ ☆
SR241K25D	150	200	216	264	18000	12000	395	100	110	235	3050	△ ☆
SR271K25D	180	230	255	311	18000	12000	455	100	120	245	2600	△ ☆
SR301K25D	195	250	270	330	18000	12000	505	100	125	255	2400	△ ☆
SR331K25D	210	275	297	363	18000	12000	545	100	130	270	2200	△ ☆
SR361K25D	230	300	324	396	18000	12000	595	100	160	315	2050	△ ☆
SR391K25D	250	330	351	429	18000	12000	650	100	175	342	1900	△ ☆
SR431K25D	275	370	387	473	18000	12000	710	100	190	370	1700	△ ☆
SR471K25D	300	385	423	517	18000	12000	775	100	200	390	1600	△ ☆
SR511K25D	320	420	459	561	18000	12000	840	100	210	422	1400	△ ☆
SR561K25D	360	470	522	638	18000	12000	910	100	215	460	1200	△ ☆
SR621K25D	390	505	558	682	18000	12000	1025	100	225	495	1800	△ ☆
SR681K25D	420	560	612	748	18000	12000	1120	100	230	515	1100	△ ☆
SR751K25D	460	615	675	825	18000	12000	1240	100	250	530	1000	△ ☆
SR781K25D	485	640	702	858	18000	12000	1290	100	260	540	980	△ ☆
SR821K25D	510	675	738	902	18000	12000	1350	100	270	550	920	△ ☆
SR911K25D	550	745	819	1001	18000	12000	1400	100	300	600	880	△ ☆
SR102K25D	625	825	900	1100	18000	12000	1620	100	340	630	760	△ ☆
SR112K25D	680	895	962	1175	18000	12000	1800	100	390	700	650	△ ☆

Remark:

1. Please refer "How to Order" for details
2. All parts approved as follows:
 - (1) △: **UL 1449** recognized (File # E309297).
 - (2) ☆: **cUL** (CSA 22.2 #1 certified, File # E309297).
 - (3) **CQC** recognized for all part numbers(CQC04001010932)

Type Number	Maximum Allowable Voltage		Varistor Voltage		Withstanding Surge Current (8/20 μ s)		Max. Clamping Voltage (8/20 μ s)		Maximum Energy	Typical Capacitance	Safety Approval	
	Acrms	DC	DC Volts		1 time	2 times	Vc	Ip	10/1000 μ s	@1kHz		
	Volts	Volts	Min	Max	Amps		Volts	Amps	Joules	pF		
SR820K05E	50	66	74	90	800	600	135	5	3.5	355	△	☆
SR181K05E	120	160	170	207	800	600	320	5	8	130	△	☆
SR201K05E	130	175	185	225	800	600	340	5	8.5	120	△	☆
SR221K05E	140	180	198	242	800	600	360	5	9	110	△	☆
SR241K05E	150	200	216	264	800	600	395	5	10.5	100	△	☆
SR271K05E	180	230	255	311	800	600	475	5	11	90	△	☆
SR301K05E	195	250	270	330	800	600	525	5	12	84	△	☆
SR331K05E	210	275	297	363	800	600	540	5	13	75	△	☆
SR361K05E	230	300	324	396	800	600	595	5	16	69	△	☆
SR391K05E	250	330	351	429	800	600	650	5	17	63	△	☆
SR431K05E	275	370	387	473	800	600	710	5	20	57	△	☆
SR471K05E	300	385	423	517	800	600	775	5	21	50	△	☆
SR511K05E	320	420	459	561	800	600	865	5	22	35	△	☆
SR561K05E	360	470	522	638	800	600	960	5	23	32	△	☆
SR621K05E	390	505	558	682	800	600	1040	5	25	30	△	☆
SR681K05E	420	560	612	748	800	600	1120	5	26	27	△	☆

Remark:

- Please refer "How to Order" for details
- All parts approved as follows:
 - △: **UL 1449** recognized (File # E309297).
 - ☆: **cUL** (CSA 22.2 #1 certified, File # E309297).
 - ◇: **VDE/CECC 42000/42200/42201**, IEC 61051-1/61051-2/61051-2-2 (Certificate # 40003435)
 - #: **VDE/IEC 60950-1,Annex Q** (Certificate # 40003435)
 - CQC** recognized for all part numbers (CQC04001010926 ~ CQC04001010931)

Type Number	Maximum Allowable Voltage		Varistor Voltage		Withstanding Surge Current (8/20 μ s)		Max. Clamping Voltage (8/20 μ s)		Maximum Energy	Typical Capacitance	Safety Approval		
	Acrms	DC	DC Volts		1 time	2 times	Vc	Ip	10/1000 μ s	@1kHz			
	Volts	Volts	Min	Max	Amps		Volts	Amps	Joules	pF			
SR820K07E	50	66	74	90	1750	1250	135	10	7.0	790	△	☆	◇
SR181K07E	120	160	170	207	1750	1250	320	10	16.0	210	△	☆	◇
SR201K07E	130	175	185	225	1750	1250	340	10	17.5	200	△	☆	◇
SR221K07E	140	180	198	242	1750	1250	360	10	19.0	190	△	☆	◇
SR241K07E	150	200	216	264	1750	1250	395	10	21.0	170	△	☆	◇
SR271K07E	180	230	255	311	1750	1250	475	10	24.0	150	△	☆	◇
SR301K07E	195	250	270	330	1750	1250	525	10	26.0	140	△	☆	◇
SR331K07E	210	275	297	363	1750	1250	540	10	28.0	130	△	☆	◇
SR361K07E	230	300	324	396	1750	1250	595	10	32.0	123	△	☆	◇
SR391K07E	250	330	351	429	1750	1250	650	10	35.0	116	△	☆	◇
SR431K07E	275	370	387	473	1750	1250	710	10	40.0	108	△	☆	◇
SR471K07E	300	385	423	517	1750	1250	775	10	42.0	100	△	☆	◇
SR511K07E	320	420	459	561	1750	1250	865	10	46.0	78	△	☆	◇
SR561K07E	360	470	522	638	1750	1250	960	10	47.0	75	△	☆	◇
SR621K07E	390	505	558	682	1750	1250	1040	10	51.0	72	△	☆	◇
SR681K07E	420	560	612	748	1750	1250	1120	10	57.0	69	△	☆	◇

1. Please refer "How to Order" for details

2. Safety approval: please refer to "Remark" above.

Type Number	Maximum Allowable Voltage		Varistor Voltage		Withstanding Surge Current (8/20 μs)		Max. Clamping Voltage (8/20 μs)		Maximum Energy	Typical Capacitance	Safety Approval	
	Acrms	DC	DC Volts		1 time	2 times	Vc	Ip	10/1000μs	@1kHz		
	Volts	Volts	Min	Max	Amps		Volts	Amps	Joules	pF		
SR820K10E	50	66	74	90	3500	2500	135	25	14	1780	△	☆◇
SR181K10E	120	160	170	207	3500	2500	320	25	33	460	△	☆◇
SR201K10E	130	175	185	225	3500	2500	340	25	35	430	△	☆◇
SR221K10E	140	180	198	242	3500	2500	360	25	39	410	△	☆◇
SR241K10E	150	200	216	264	3500	2500	395	25	42	380	△	☆◇
SR271K10E	180	230	255	311	3500	2500	475	25	49	350	△	☆◇
SR301K10E	195	250	270	330	3500	2500	525	25	53	320	△	☆◇
SR331K10E	210	275	297	363	3500	2500	540	25	58	300	△	☆◇
SR361K10E	230	300	324	396	3500	2500	595	25	65	285	△	☆◇
SR391K10E	250	330	351	429	3500	2500	650	25	70	270	△	☆◇
SR431K10E	275	370	387	473	3500	2500	710	25	80	255	△	☆◇
SR471K10E	300	385	423	517	3500	2500	775	25	85	230	△	☆◇
SR511K10E	320	420	459	561	3500	2500	865	25	92	210	△	☆◇
SR561K10E	360	470	522	638	3500	2500	960	25	97	170	△	☆◇
SR621K10E	390	505	558	682	3500	2500	1040	25	107	146	△	☆◇
SR681K10E	420	560	612	748	3500	2500	1120	25	110	136	△	☆◇
SR751K10E	460	615	675	825	3500	2500	1240	25	115	124	△	☆◇
SR781K10E	485	640	702	858	3500	2500	1290	25	120	120	△	☆◇
SR821K10E	510	675	738	902	3500	2500	1350	25	125	110	△	☆◇
SR911K10E	550	745	819	1001	3500	2500	1400	25	130	90	△	☆◇
SR102K10E	625	825	900	1100	3500	2500	1620	25	145	80	△	☆◇
SR112K10E	680	895	962	1175	3500	2500	1800	25	155	70	△	☆◇

1. Please refer "How to Order" for details

2. Safety approval: please refer to "Remark" on page 9.

Type Number	Maximum Allowable Voltage		Varistor Voltage		Withstanding Surge Current (8/20 μs)		Max. Clamping Voltage (8/20 μs)		Maximum Energy	Typical Capacitance	Safety Approval	
	Acrms	DC	DC Volts		1 time	2 times	Vc	Ip	10/1000μs	@1kHz		
	Volts	Volts	Min	Max	Amps		Volts	Amps	Joules	pF		
SR820K14E	50	66	74	90	6000	5000	135	50	28	3310	△	☆◇#
SR181K14E	120	160	170	207	6000	5000	320	50	56	800	△	☆◇#
SR201K14E	130	175	185	225	6000	5000	340	50	70	770	△	☆◇#
SR221K14E	140	180	198	242	6000	5000	360	50	78	740	△	☆◇#
SR241K14E	150	200	216	264	6000	5000	395	50	84	700	△	☆◇#
SR271K14E	180	230	255	311	6000	5000	475	50	99	640	△	☆◇#
SR301K14E	195	250	270	330	6000	5000	525	50	107	620	△	☆◇#
SR331K14E	210	275	297	363	6000	5000	540	50	115	580	△	☆◇#
SR361K14E	230	300	324	396	6000	5000	595	50	140	540	△	☆◇#
SR391K14E	250	330	351	429	6000	5000	650	50	150	500	△	☆◇#
SR431K14E	275	370	387	473	6000	5000	710	50	165	460	△	☆◇#
SR471K14E	300	385	423	517	6000	5000	775	50	175	400	△	☆◇#
SR511K14E	320	420	459	561	6000	5000	865	50	190	350	△	☆◇#
SR561K14E	360	470	522	638	6000	5000	960	50	210	320	△	☆◇#
SR621K14E	390	505	558	682	6000	5000	1040	50	215	270	△	☆◇#
SR681K14E	420	560	612	748	6000	5000	1120	50	225	250	△	☆◇#
SR751K14E	460	615	675	825	6000	5000	1240	50	230	230	△	☆◇#
SR781K14E	485	640	702	858	6000	5000	1290	50	235	210	△	☆◇#
SR821K14E	510	675	738	902	6000	5000	1350	50	240	190	△	☆◇#
SR911K14E	550	745	819	1001	6000	5000	1400	50	255	170	△	☆◇#
SR102K14E	625	825	900	1100	6000	5000	1620	50	290	165	△	☆◇#
SR112K14E	680	895	962	1175	6000	5000	1800	50	310	140	△	☆◇#

1. Please refer "How to Order" for details

2. Safety approval: please refer to "REMARK" ON PAGE 9.

Type Number	Maximum Allowable Voltage		Varistor Voltage		Withstanding Surge Current (8/20 μs)		Max. Clamping Voltage (8/20 μs)		Maximum Energy	Typical Capacitance	Safety Approval	
	Acrms	DC	DC Volts		1 time	2 times	Vc	Ip	10/1000μs	@1kHz		
	Volts	Volts	Min	Max	Amps		Volts	Amps	Joules	pF		
SR820K18E	50	66	74	90	8000	5000	135	75	46	3500	△ ☆ ◇ #	
SR181K18E	120	160	170	207	9000	6000	320	75	70	1600	△ ☆ ◇ #	
SR201K18E	130	175	185	225	9000	6000	340	75	130	1270	△ ☆ ◇ #	
SR221K18E	140	180	198	242	9000	6000	360	75	135	1220	△ ☆ ◇ #	
SR241K18E	150	200	216	264	9000	6000	395	75	140	1200	△ ☆ ◇ #	
SR271K18E	180	230	255	311	9000	6000	475	75	150	1050	△ ☆ ◇ #	
SR301K18E	195	250	270	330	9000	6000	525	75	170	1010	△ ☆ ◇ #	
SR331K18E	210	275	297	363	9000	6000	540	75	190	950	△ ☆ ◇ #	
SR361K18E	230	300	324	396	9000	6000	595	75	215	870	△ ☆ ◇ #	
SR391K18E	250	330	351	429	9000	6000	650	75	240	800	△ ☆ ◇ #	
SR431K18E	275	370	387	473	9000	6000	710	75	260	730	△ ☆ ◇ #	
SR471K18E	300	385	423	517	9000	6000	775	75	290	660	△ ☆ ◇ #	
SR511K18E	320	420	459	561	9000	6000	865	75	314	570	△ ☆ ◇ #	
SR561K18E	360	470	522	638	9000	6000	960	75	320	520	△ ☆ ◇ #	
SR621K18E	390	505	558	682	9000	6000	1040	75	330	470	△ ☆ ◇ #	
SR681K18E	420	560	612	748	9000	6000	1120	75	340	430	△ ☆ ◇ #	
SR751K18E	460	615	675	825	9000	6000	1240	75	360	390	△ ☆ ◇ #	
SR781K18E	485	640	702	858	9000	6000	1290	75	365	370	△ ☆ ◇ #	
SR821K18E	510	675	738	902	9000	6000	1350	75	388	310	△ ☆ ◇ #	
SR911K18E	550	745	819	1001	9000	6000	1400	75	405	280	△ ☆ ◇ #	
SR102K18E	625	825	900	1100	9000	6000	1620	75	450	250	△ ☆ ◇ #	
SR112K18E	680	895	962	1175	9000	6000	1800	75	500	230	△ ☆ ◇ #	

1. Please refer "How to Order" for details

2. Safety approval: please refer to "Remark" on page 9.

Type Number	Maximum Allowable Voltage		Varistor Voltage		Withstanding Surge Current (8/20 μs)		Max. Clamping Voltage (8/20 μs)		Maximum Energy	Typical Capacitance	Safety Approval	
	Acrms	DC	DC Volts		1 time	2 times	Vc	Ip	10/1000μs	@1kHz		
	Volts	Volts	Min	Max	Amps		Volts	Amps	Joules	pF		
SR820K20E	50	66	74	90	10000	6500	135	100	56	5300	△ ☆ ◇ #	
SR181K20E	120	160	170	207	12000	7500	320	100	135	1800	△ ☆ ◇ #	
SR201K20E	130	175	185	225	12000	7500	340	100	140	1700	△ ☆ ◇ #	
SR221K20E	140	180	198	242	12000	7500	360	100	155	1600	△ ☆ ◇ #	
SR241K20E	150	200	216	264	12000	7500	395	100	170	1500	△ ☆ ◇ #	
SR271K20E	180	230	255	311	12000	7500	475	100	190	1300	△ ☆ ◇ #	
SR301K20E	195	250	270	330	12000	7500	525	100	210	1200	△ ☆ ◇ #	
SR331K20E	210	275	297	363	12000	7500	540	100	228	1100	△ ☆ ◇ #	
SR361K20E	230	300	324	396	12000	7500	595	100	275	1050	△ ☆ ◇ #	
SR391K20E	250	330	351	429	12000	7500	650	100	305	1000	△ ☆ ◇ #	
SR431K20E	275	370	387	473	12000	7500	710	100	330	950	△ ☆ ◇ #	
SR471K20E	300	385	423	517	12000	7500	775	100	350	900	△ ☆ ◇ #	
SR511K20E	320	420	459	561	12000	7500	865	100	382	800	△ ☆ ◇ #	
SR561K20E	360	470	522	638	12000	7500	960	100	395	760	△ ☆ ◇ #	
SR621K20E	390	505	558	682	12000	7500	1040	100	410	710	△ ☆ ◇ #	
SR681K20E	420	560	612	748	12000	7500	1120	100	423	670	△ ☆ ◇ #	
SR751K20E	460	615	675	825	12000	7500	1240	100	435	620	△ ☆ ◇ #	
SR781K20E	485	640	702	858	12000	7500	1290	100	450	580	△ ☆ ◇ #	
SR821K20E	510	675	738	902	12000	7500	1350	100	460	530	△ ☆ ◇ #	
SR911K20E	550	745	819	1001	12000	7500	1400	100	510	470	△ ☆ ◇ #	
SR102K20E	625	825	900	1100	12000	7500	1620	100	560	425	△ ☆ ◇ #	
SR112K20E	680	895	962	1175	12000	7500	1800	100	620	380	△ ☆ ◇ #	

1. Please refer "How to Order" for details

2. Safety approval: please refer to "Remark" on page 9.

V-I Curve for SR180K~680K05D(E) Series

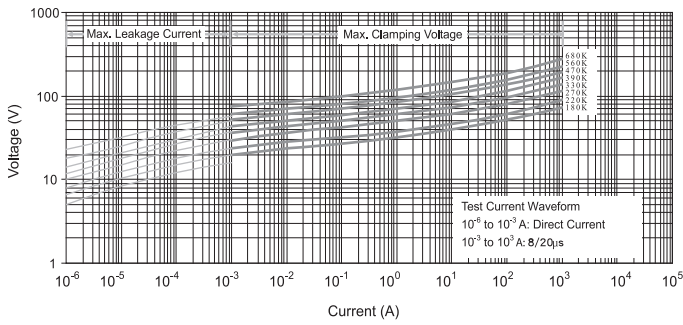

V-I Curve for SR180K~680K07D(E) Series

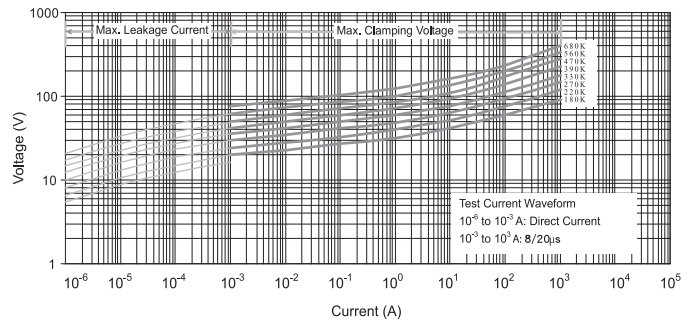

V-I Curve for SR820K~431K05D(E) Series

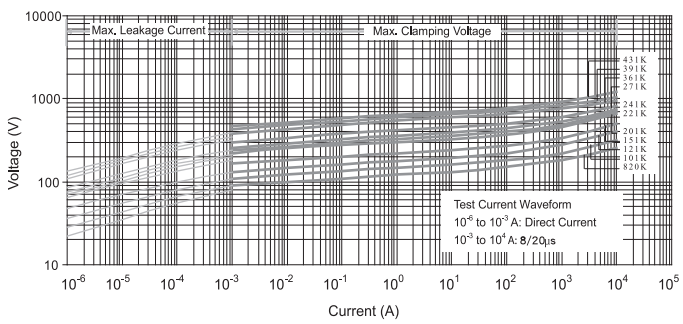

V-I Curve for SR820K~431K07D(E) Series

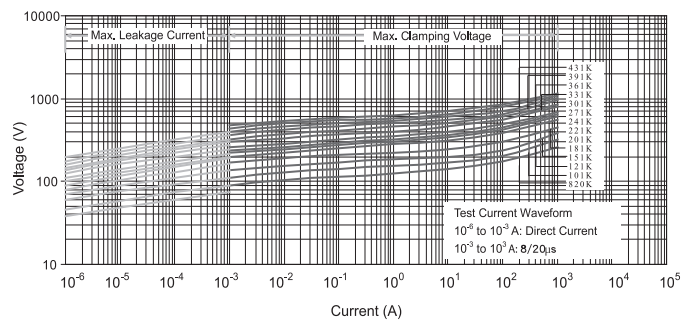

V-I Curve for SR471K~561K05D(E) Series

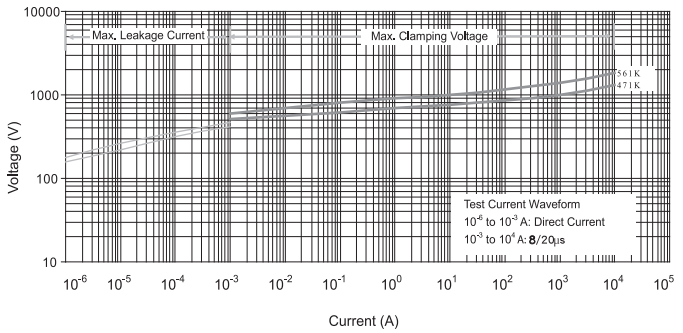

V-I Curve for r SR471K~561K07D(E) Series

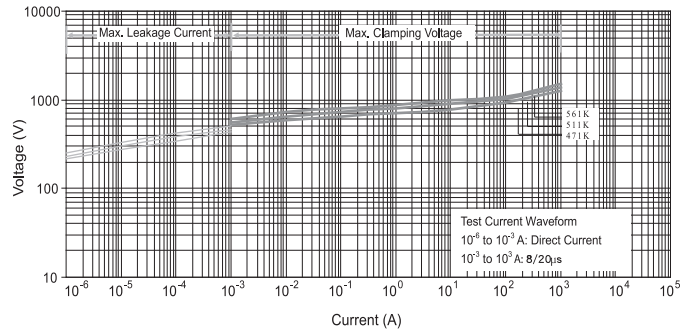

V-I Curve for SR180K~680K10D(E) Series

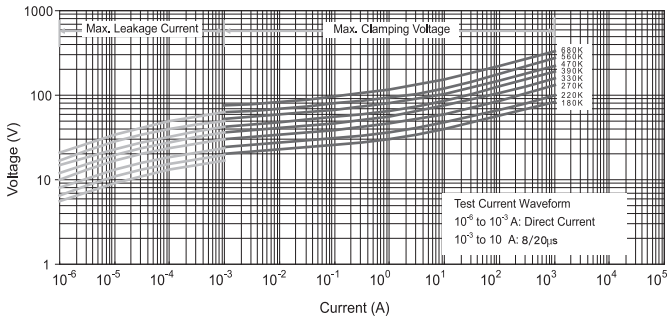

V-I Curve for SR180K ~ 680K14D(E) Series

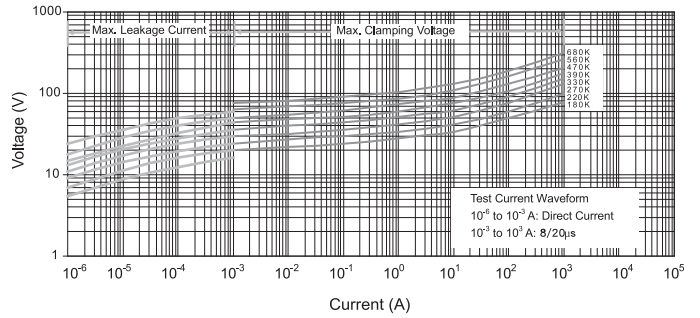

V-I Curve for SR820K ~ 431K10D(E) Series

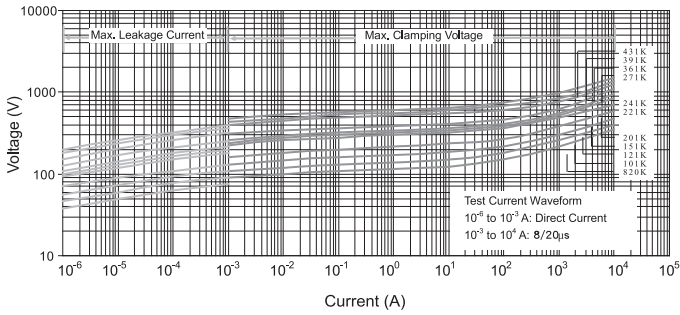

V-I Curve for SR820K~431K14D(E) Series

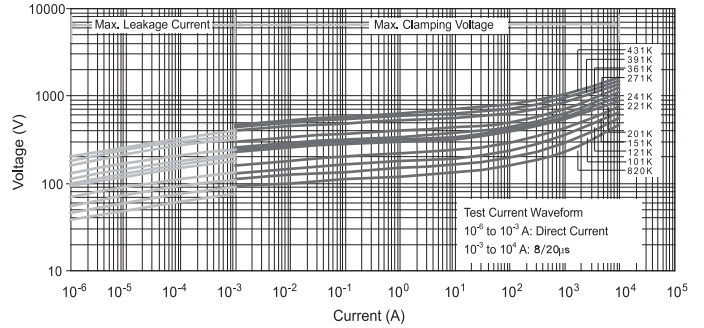

V-I Curve for 471K~112K10D (E) Series

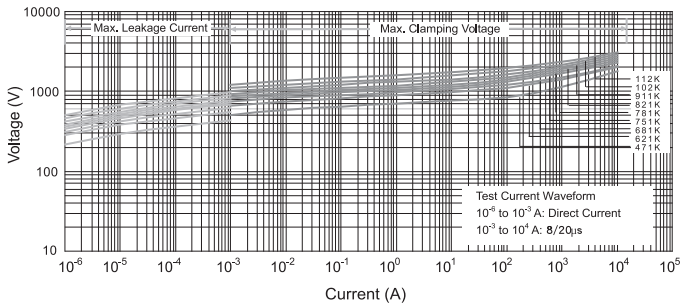

V-I Curve for SR471K ~ 112K14D(E) Series

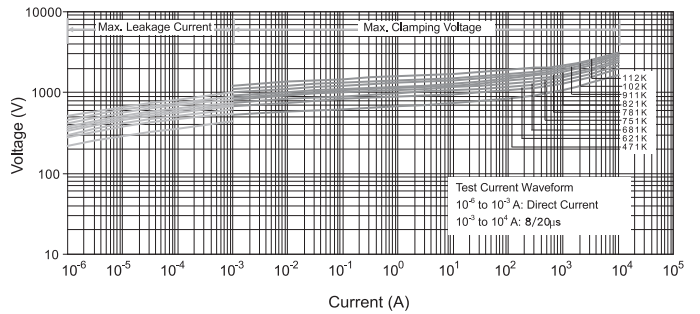

V-I Curve for SR820K~ 431K18E Series

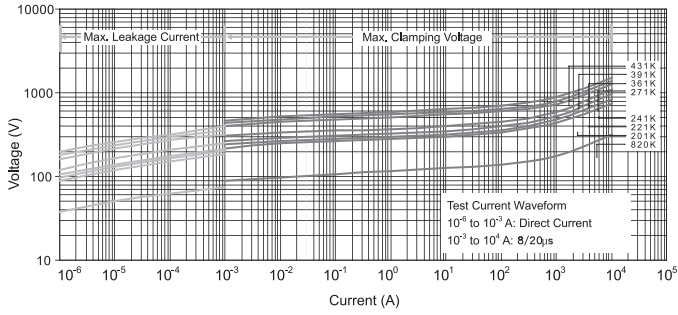

V-I Curve for SR820K~ 431K20DE Series

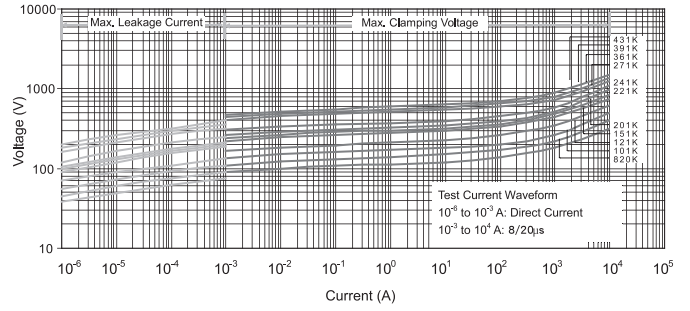

V-I Curve for SR471K~ 112K18E Series

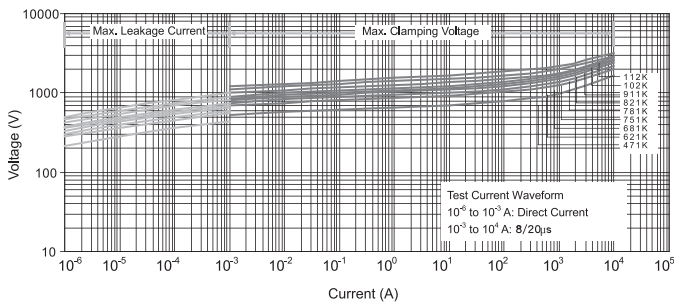

V-I Curve for SR471K~ 112K20D(E) Series

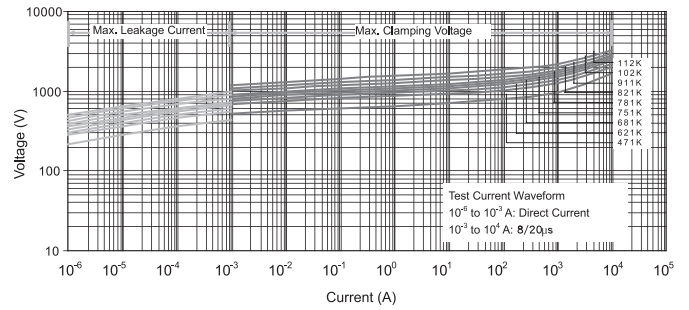

V-I Curve for SR201K~ 431K25D Series

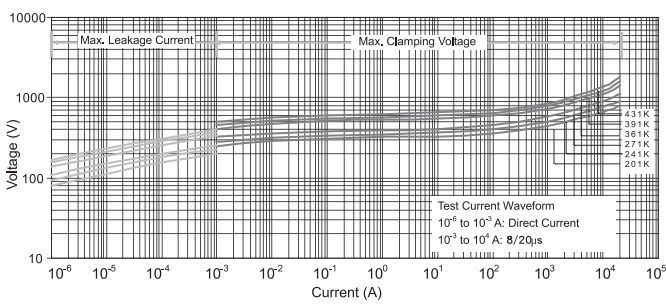

V-I Curve for SR471K~ 951K25D Series

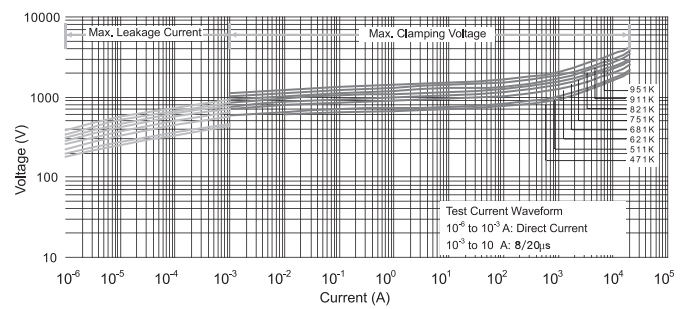

A. Bulk packing:

Disk size mm	Varistor Voltage	Q'ty pcs/bag	Q'ty pcs/Carton
5Ø	All	1000	10000
7Ø	All	500	5000
10Ø	180K-471K	500	5000
	Above 511K	300	3000
14Ø	180K-751K	300	3000
	Above 821K	200	2000
18Ø	All	200	2000
20Ø	180K-621K	100	1000
	Above 681K	50	500
25Ø	181K-621K	50	500
	Above 681K	30	300

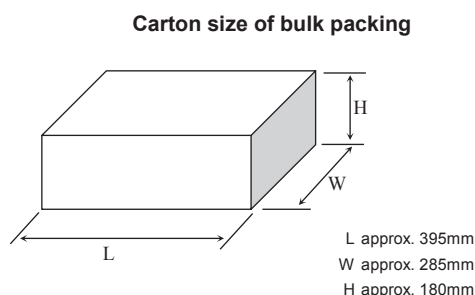

B. Tape and Reel:

Disk size mm	Varistor Voltage	AMMO BOX		REEL		
		PCS / BOX	BOX / CARTON	PCS / REEL	REELS / BOX	BOX / CARTON
5Ø	≤431K	1500	10	1500	2	5
5Ø	≥471K	1000	10	1000	2	5
7Ø	≤431K	1500	10	1500	2	5
7Ø	≥471K	1000	10	1000	2	5
10Ø	≤431K	500	10	500	2	5
10Ø	≥471K	300	10	300	2	5
14Ø	≤431K	500	8	500	2	5
14Ø	≥471K	300	8	300	2	5
18Ø	≤431K	500	8	500	2	5
18Ø	≥471K	300	8	300	2	5
20Ø	≤431K	500	8	500	2	5
20Ø	≥471K	300	8	300	2	5

Note: Ammo box and reel quantities may vary. Please contact sales for details.

■ Dimensions of Ammo Box and Reel:

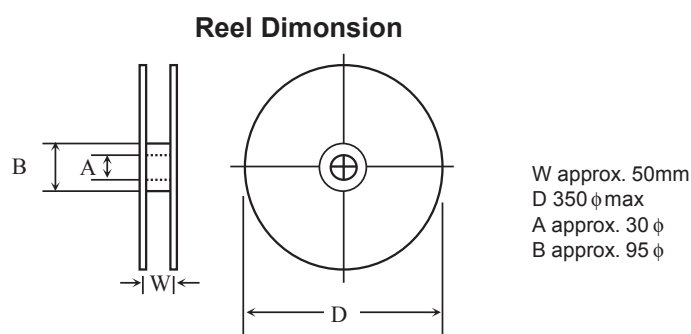
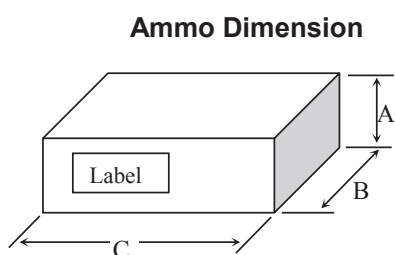

Disk size	A (max.)	B (max.)	C (max.)
5 Ø	50mm	270mm	350mm
7 Ø	50mm	270mm	350mm
10 Ø	70mm	270mm	370mm
14 Ø	70mm	270mm	370mm
18 Ø, 20 Ø	70mm	270mm	370mm

■ Taping Code:

Varistor series	Lead spacing	Packing type	Lead type			
			Straight	Outward crimped	Inward crimped	Inline crimped
5D,5E	5 mm	Ammo Reel	JNE, KNE		JNC, KNC	
7D,7E	5 mm	Ammo Reel	JNE, KNE		JNC, KNC	
10D,10E	7.5 mm	Ammo Reel	AMG, TMG		AMD, TMD	
14D,14E	7.5 mm	Ammo Reel	AMG, TMG		AMD, TMD	
18E	7.5 mm	Ammo Reel	AMG, TMG		AMD, TMD	
20D,20E	7.5/10 mm	Ammo Reel	AMG, TMG		AMD, TMD	

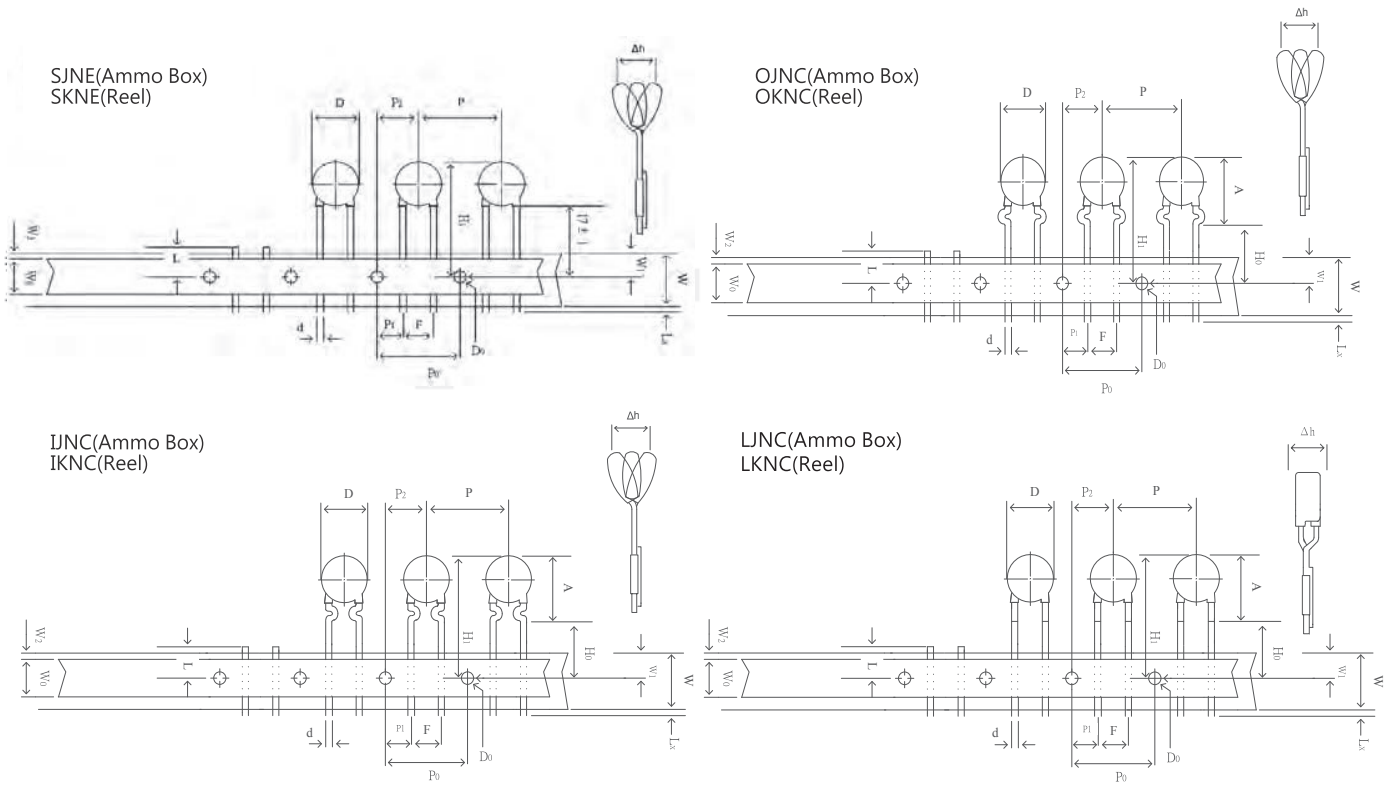

Item	Disk Size				
	5Ø (5D, 5E)		7Ø (7D, 7E)		
Taping Code	SJNE, SKNE	JNC, KNC	SJNE, SKNE	JNC, KNC	
Body Diameter	D	7Max	7Max	9Max	9Max
Lead Wire Diameter	d	0.6±0.05	0.6±0.05	0.6±0.05	0.6±0.05
Pitch of Component	P	12.7±1	12.7±1	12.7±1	12.7±1
Feed Hole Pitch	P ₀	12.7±0.3	12.7±0.3	12.7±0.3	12.7±0.3
Feed Hole Center to Lead	P ₁	3.85±0.7	3.85±0.7	3.85±0.7	3.85±0.7
Lead to Lead Distance (Center to Center)	F	5.0±0.8	5.0±0.8	5.0±0.8	5.0±0.8
Component Alignment	Δh	2.0Max	2.0Max	2.0Max	2.0Max
Base paper Tape Width	W	18+1.0/-0.5	18+1.0/-0.5	18+1.0/-0.5	18+1.0/-0.5
Adhesive Tape Width	W ₀	10Min	10Min	10Min	10Min
Hole Position	W ₁	9±0.5	9±0.5	9±0.5	9±0.5
Adhesive Tape Border	W ₂	1.5Max	1.5Max	1.5Max	1.5Max
Component Height	H ₁	30Max	30Max	32Max	32Max
Lead-Wire Clinch Height	H ₀	—	16±0.5	—	16±0.5
Lead-Wire Protrusion	L _x	1.0Max	1.0Max	1.0Max	1.0Max
Feed Hole Diameter	D ₀	4±0.2	4±0.2	4±0.2	4±0.2
Total Tape Thickness	t	< 0.7	< 0.7	< 0.7	< 0.7
Length of Clipped Lead	L	11Max	11Max	11Max	11Max
Component Height from Seating Plane	A	—	13Max	—	15Max
Hole Center to Component Center	P ₂	6.35±0.7	6.35±0.7	6.35±0.7	6.35±0.7

Based on EIA-468-B Specification

All dimensions are in millimeters.

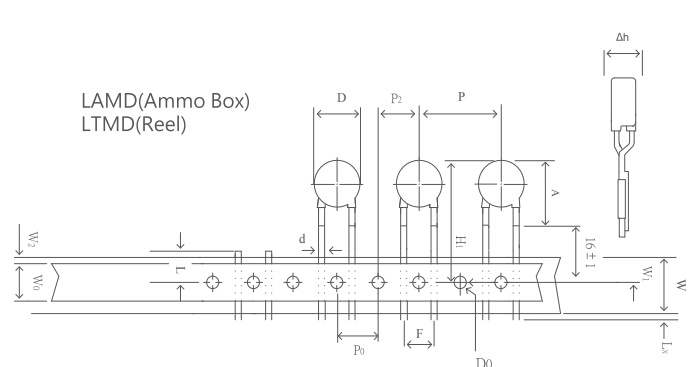
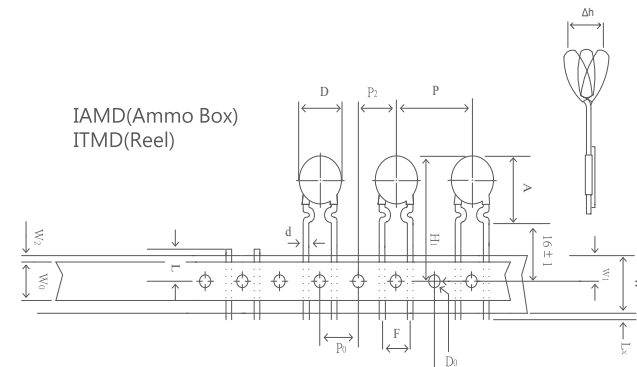
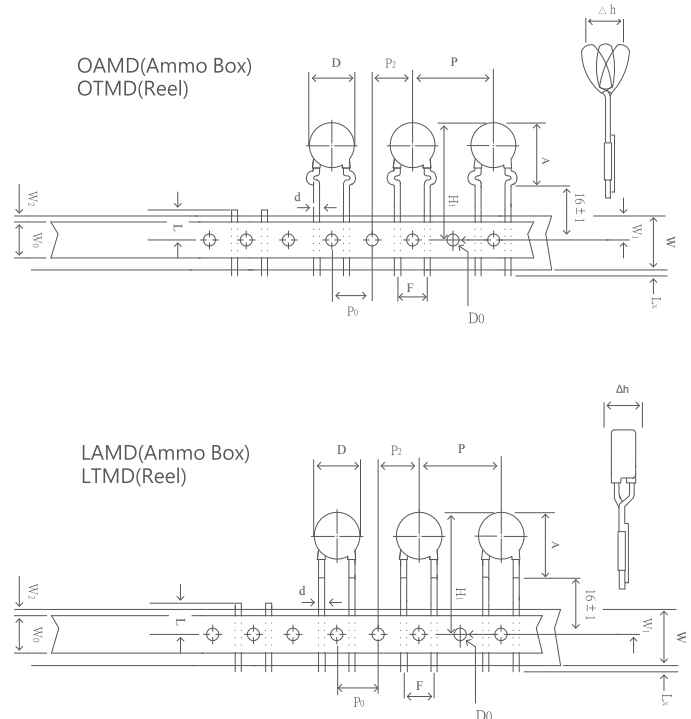
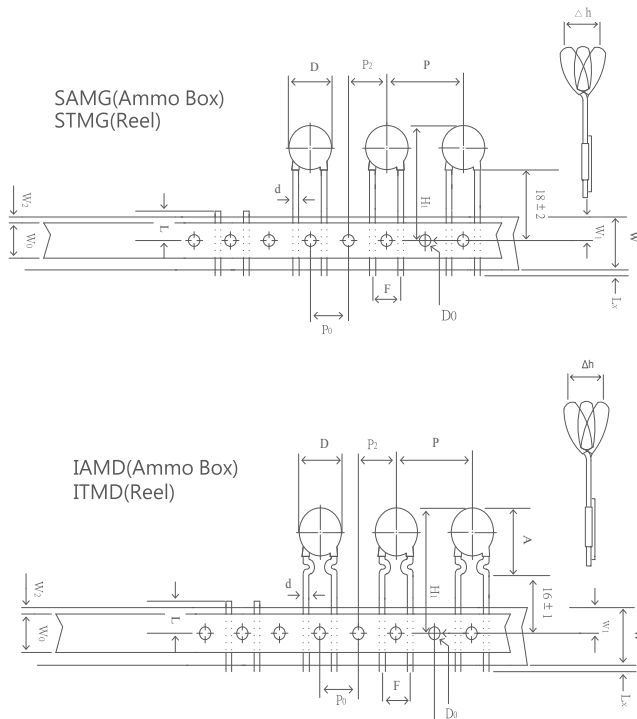

Item		Disk Size				
		10Ø (10D, 10E)			14Ø (14D, 14E)	
Taping Code		SAMG, STMG	OAMD, OTMD IAMD, ITMD	LAMD, LTMD	SAMG, STMG	AMD, TMD
Body Diameter	D	14Max	14Max	14Max	17.5Max	17.5Max
Lead Wire Diameter	d	0.8±0.05	0.8±0.05	0.8±0.05	0.8±0.05	0.8±0.05
Pitch of Component	P	25.4±1	25.4±1	25.4±1	25.4±1	25.4±1
Hole Center to Component Center	P2	12.7±0.3	12.7±0.3	12.7±0.3	12.7±0.3	12.7±0.3
Feed Hole Pitch	P0	12.7±0.3	12.7±0.3	12.7±0.3	12.7±0.3	12.7±0.3
Lead to Lead Distance (Center to Center)	F	7.5±0.8	7.5±0.8	7.5±0.8	7.5±0.8	7.5±0.8
Component Alignment	Δh	2.0Max	2.0Max	2.0Max	2.0Max	2.0Max
Base paper Tape Width	W	18+1.0/-0.5	18+1.0/-0.5	18+1.0/-0.5	18+1.0/-0.5	18+1.0/-0.5
Adhesive Tape Width	W0	10Min	10Min	10Min	10Min	10Min
Hole Position	W1	9±0.5	9±0.5	9±0.5	9±0.5	9±0.5
Adhesive Tape Border	W2	1.5Max	1.5Max	1.5Max	1.5Max	1.5Max
Component Height	H1	33Max	38.5Max	35.5Max	37Max	40Max
Lead-Wire Protrusion	Lx	1.0Max	1.0Max	1.0Max	1.0Max	1.0Max
Feed Hole Diameter	D0	4±0.2	4±0.2	4±0.2	4±0.2	4±0.2
Total Tape Thickness	t	< 0.7	< 0.7	< 0.7	< 0.7	< 0.7
Length of Clipped Lead	L	11Max	11Max	11Max	11Max	11Max
Component Height from Seating Plane	A	—	19.5Max	19.5Max	—	22.5Max

Based on EIA-468-B Specification
All dimensions are in millimeters.

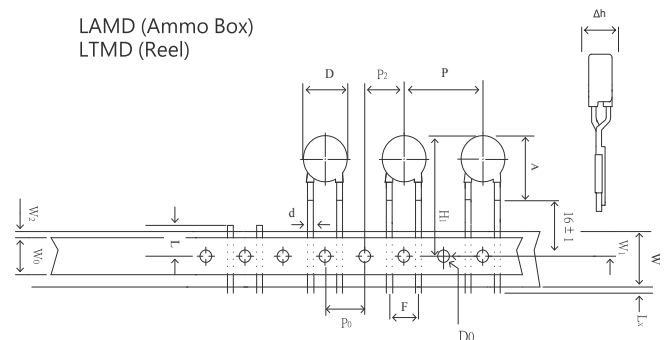
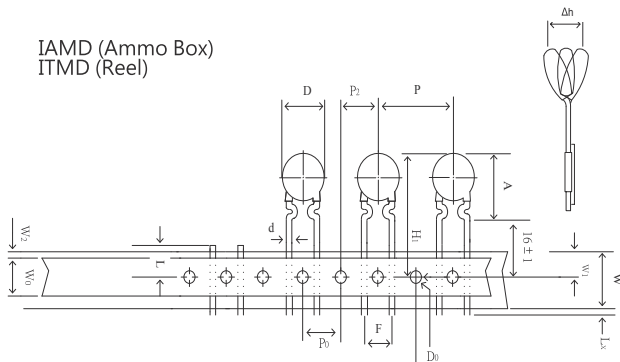
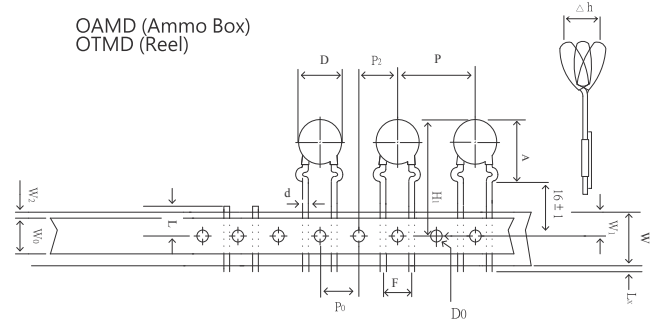
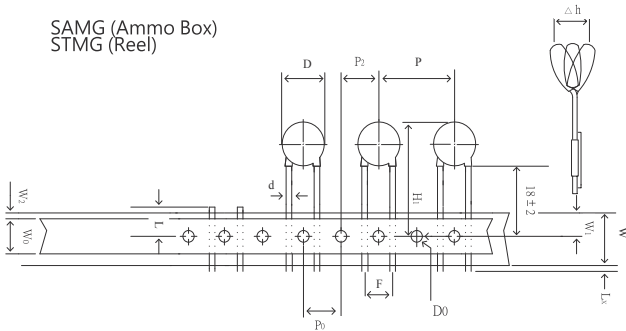

Item		Disk Size					
		20Ø (20D, 20E), 18Ø (18E)			20Ø (20D, 20E)		
		Lead Spacing 7.5 mm			Lead Spacing 10.0 mm		
Taping Code		SAMG STMG	OAMD, OTMD IAMD, ITMD	LAMD LTMD	SAMG STMG	OAMD, OTMD IAMD, ITMD	LAMD LTMD
Body Diameter	D	24Max*	24Max*	24Max*	24Max	24Max	24Max
Lead Wire Diameter	d	0.8±0.05	0.8±0.05	0.8±0.05	0.8±0.05	1.0±0.05	0.8±0.05
Pitch of Component	P	25.4±1	25.4±1	25.4±1	25.4±1	25.4±1	25.4±1
Feed Hole Pitch	P ₀	12.7±0.3	12.7±0.3	12.7±0.3	12.7±0.3	12.7±0.3	12.7±0.3
Hole Center to Component Center	P ₂	12.7±0.3	12.7±0.3	12.7±0.3	12.7±0.3	12.7±0.3	12.7±0.3
Lead to Lead Distance (Center to Center)	F	7.5±0.8	7.5±0.8	7.5±0.8	10.0±1.0	10.0±1.0	10.0±1.0
Component Alignment	Δh	2.0Max	2.0Max	2.0Max	2.0Max	2.0Max	2.0Max
Base paper Tape Width	W	18+1.0/-0.5	18+1.0/-0.5	18+1.0/-0.5	18+1.0/-0.5	18+1.0/-0.5	18+1.0/-0.5
Adhesive Tape Width	W ₀	10Min	10Min	10Min	10Min	10Min	10Min
Hole Position	W ₁	9±0.5	9±0.5	9±0.5	9±0.5	9±0.5	9±0.5
Adhesive Tape Border	W ₂	1.5Max	1.5Max	1.5Max	1.5Max	1.5Max	1.5Max
Component Height	H ₁	48Max*	48Max*	48Max*	48Max	48Max	48Max
Lead-Wire Protrusion	L _x	1.0Max	1.0Max	1.0Max	1.0Max	1.0Max	1.0Max
Feed Hole Diameter	D ₀	4±0.2	4±0.2	4±0.2	4±0.2	4±0.2	4±0.2
Total Tape Thickness	t	< 0.7	< 0.7	< 0.7	< 0.7	< 0.7	< 0.7
Length of Clipped Lead	L	11Max	11Max	11Max	11Max	11Max	11Max
Component Height from Seating Plane	A	—	29Max*	28Max*	—	29Max	28Max

Based on EIA-468-B Specification

* For 18Ø, D=22max, H1=46max and A=26max.

All dimensions are in millimeters.

Straight Leads Part Number No Suffix

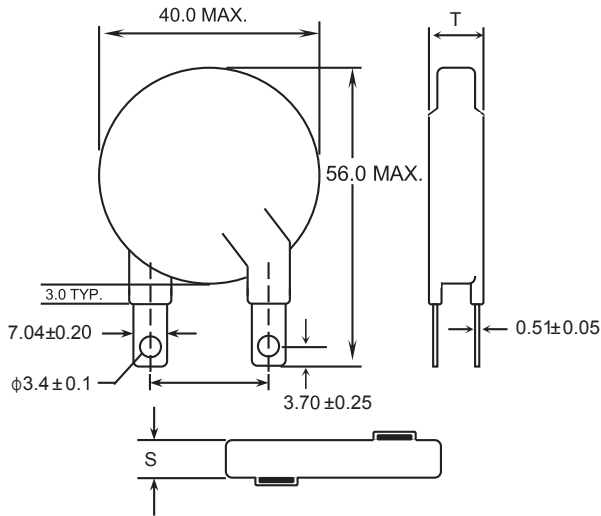

90° Bend Leads Part Number Suffix "Q"

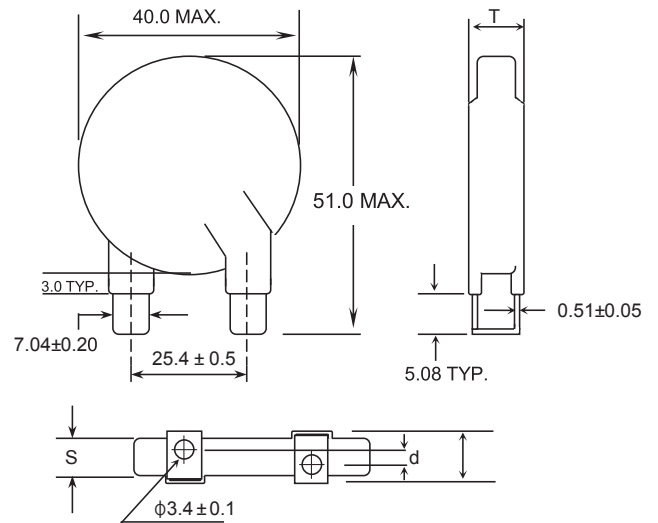

Part Number	Maximum Ratings					Electrical Characteristics					Tmax.	s	d
	Continuous Rated Voltage		Rated Single Pulse Transient			Varistor Voltage @ 1mA DC		Maximum Clamping Voltage @ Test Current 8/20µs		Typical Capacitance @1KHZ 25°C			
	AC RMS Volts	DC Volts	Energy	8/20µs Peak		Min Volts	Max Volts	Volts	Amps	PF			
			10/1000µs Jules	1 time Kamps	2 times Kamps								
mm	mm	mm	mm	mm									
SR201K32D□	130	175	210	30	20	184	224	340	200	4700	7.5	2.5±1.0	5.7±1.0
SR221K32D□	140	180	225	30	20	198	242	360	200	4300	7.5	2.5±1.0	5.5±1.0
SR241K32D□	150	200	240	30	20	216	264	395	200	4000	7.5	2.8±1.0	5.4±1.0
SR271K32D□	180	230	255	30	20	255	311	455	200	3500	8.5	2.8±1.0	5.2±1.0
SR331K32D□	210	275	300	30	20	297	363	550	200	3000	9.0	3.1±1.0	4.8±1.0
SR361K32D□	230	300	315	30	20	324	396	595	200	2800	9.0	3.3±1.0	4.6±1.0
SR391K32D□	250	330	330	30	20	351	429	650	200	2500	9.0	3.6±1.0	4.4±1.0
SR431K32D□	275	370	360	30	20	387	473	710	200	2200	9.0	3.6±1.0	4.2±1.0
SR471K32D□	300	385	380	30	20	423	517	775	200	2000	9.7	3.8±1.0	4.2±1.0
SR511K32D□	320	420	430	30	20	459	561	840	200	1900	9.7	3.8±1.0	4.0±1.0
SR621K32D□	390	505	470	30	20	558	682	1025	200	1600	9.7	4.3±1.0	3.9±1.0
SR681K32D□	420	560	495	30	20	612	748	1120	200	1500	9.7	4.6±1.0	3.6±1.0
SR751K32D□	460	615	520	30	20	675	825	1240	200	1400	10.5	4.8±1.0	3.3±1.0
SR781K32D□	485	640	550	30	20	702	858	1290	200	1300	10.5	4.8±1.0	3.1±1.0
SR821K32D□	510	675	580	30	20	738	902	1355	200	1200	10.5	5.1±1.0	2.9±1.0
SR911K32D□	550	745	620	30	20	819	1001	1500	200	1150	11.5	5.6±1.0	2.5±1.0
SR951K32D□	575	765	650	30	20	855	1043	1570	200	1100	11.5	5.6±1.0	2.3±1.0
SR102K32D□	625	825	680	30	20	900	1100	1650	200	1000	12.0	5.8±1.0	2.1±1.0
SR112K32D□	680	895	760	30	20	962	1175	1815	200	900	12.0	6.4±1.0	2.1±1.0

□ - Part Number Suffix Code (ie: SR 201K32DML)

Q - 90° Bend Lead

F - Un-Coated Disk - with Leads

ML - One Side coated Disk - with one Left Orientation Lead only

NL - Uncoated Disk - with one Left Orientation Lead only

L - Straight Lead - Left Side Lead Orientation

R - Uncoated Disk - without Leads

M - One Side Coated Disk - with one Right Orientation Lead only

N - Uncoated Disk - with one Right Orientation Lead only

UL 1449 recognized (File # E309297)

cUL (CSA 22.2 #1 certified, File # E309297)

Straight Leads Part Number No Suffix

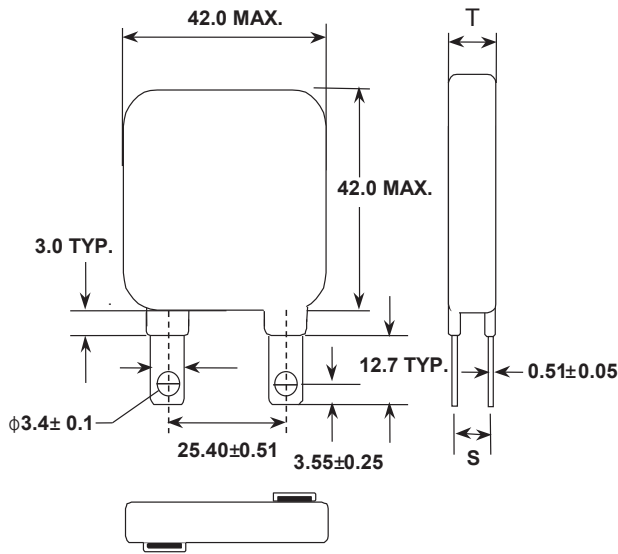

90° Bend Leads Part Number Suffix " Q "

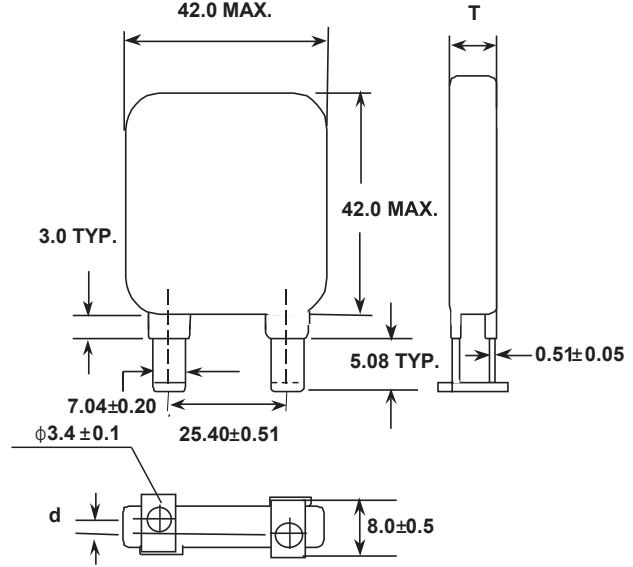

Part Number	Maximum Ratings					Electrical Characteristics						Tmax.	s	d
	Continuous Rated Voltage		Rated Single Pulse Transient			Varistor Voltage @ 1mA DC		Maximum Clamping Voltage @ Test Current 8/20µs		Typical Capacitance @1KHZ 25°C				
	AC RMS Volts	DC Volts	Energy	8/20µs Peak		Min Volts	Max Volts	Volts	Amps	PF				
			10/1000µs Jules	1 time Kamps	2 times Kamps									
SR201K34R□	130	175	310	40	25	185	225	340	300	10000	7.5	2.5±1.0	5.7±1.0	
SR221K34R□	140	180	330	40	25	198	242	360	300	9000	7.5	2.5±1.0	5.5±1.0	
SR241K34R□	150	200	360	40	25	216	264	395	300	8000	7.5	2.8±1.0	5.4±1.0	
SR271K34R□	180	230	390	40	25	255	311	455	300	7100	8.5	2.8±1.0	5.2±1.0	
SR301K34R□	195	250	405	40	25	270	330	505	300	6500	9.0	3.0±1.0	5.0±1.0	
SR331K34R□	210	275	430	40	25	297	363	550	300	6000	9.0	3.1±1.0	4.8±1.0	
SR361K34R□	230	300	460	40	25	324	396	595	300	5600	9.0	3.3±1.0	4.6±1.0	
SR391K34R□	250	330	490	40	25	351	429	650	300	5000	9.0	3.6±1.0	4.4±1.0	
SR431K34R□	275	370	550	40	25	387	473	710	300	4500	9.0	3.6±1.0	4.2±1.0	
SR471K34R□	300	385	600	40	25	423	517	775	300	4000	9.7	3.8±1.0	4.2±1.0	
SR511K34R□	320	420	640	40	25	459	561	840	300	3800	9.7	3.8±1.0	4.0±1.0	
SR561K34R□	360	470	710	40	25	522	638	910	300	3500	9.7	4.0±1.0	4.0±1.0	
SR621K34R□	390	505	800	40	25	558	682	1025	300	3200	9.7	4.3±1.0	3.9±1.0	
SR681K34R□	420	560	910	40	25	612	748	1120	300	2900	9.7	4.6±1.0	3.6±1.0	
SR751K34R□	460	615	980	40	25	675	825	1240	300	2700	10.5	4.8±1.0	3.3±1.0	
SR781K34R□	485	640	1020	40	25	702	858	1290	300	2500	10.5	5.1±1.0	3.1±1.0	
SR821K34R□	510	675	1100	40	25	738	902	1355	300	2300	10.5	5.6±1.0	2.9±1.0	
SR911K34R□	550	745	1150	40	25	819	1001	1500	300	2100	11.5	5.6±1.0	2.5±1.0	
SR951K34R□	575	765	1200	40	25	855	1045	1570	300	1900	11.5	5.6±1.0	2.3±1.0	
SR102K34R□	625	825	1250	40	25	900	1100	1650	300	1700	12.0	5.8±1.0	2.1±1.0	
SR112K34R□	680	895	1350	40	25	962	1175	1815	300	1500	12.0	6.4±1.0	2.1±1.0	

□ - Part Number Suffix Code (ie: SR201K34RML)

No suffix - Straight Lead

Q - 90° Bend Lead

F - Un-Coated Disk - with Leads

ML - One Side coated Disk - with one Left Orientation Lead only

NL - Uncoated Disk - with one Left Orientation Lead only

L - Straight Lead - Left Side Lead Orientation

R - Uncoated Disk - without Leads

M - One Side Coated Disk - with one Right Orientation Lead only

N - Uncoated Disk - with one Right Orientation Lead only

UL 1449 recognized (File # E309297)

cUL (CSA 22.2 #1 certified, File # E309297)

Straight Leads Part Number No Suffix

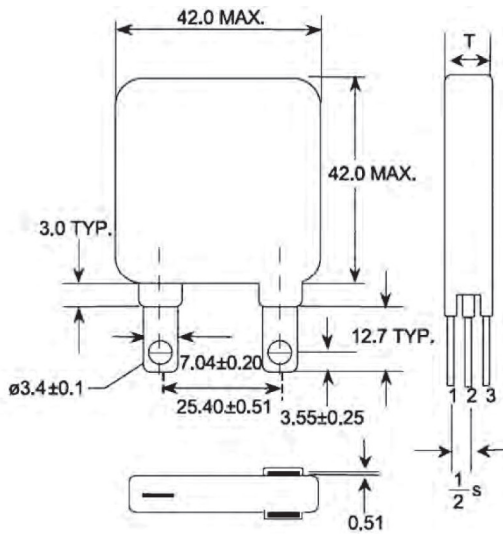

90° Bend Leads Part Number Suffix "Q"

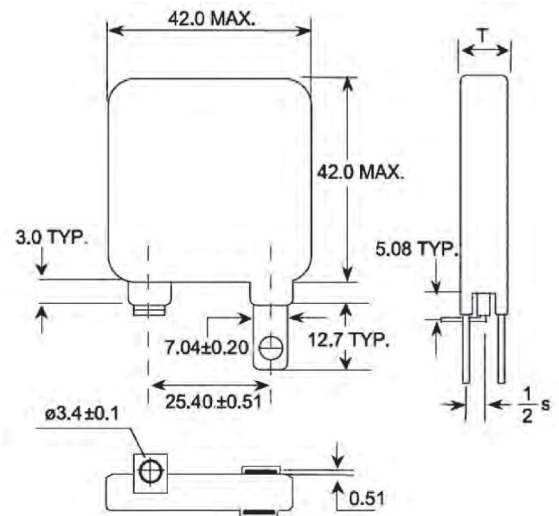

Part Number	Maximum Ratings							Electrical Characteristics					Tmax.	s
	Continuous Rated Voltage		Rated Single Pulse Transient				Varistor Voltage @ 1mA DC		Maximum Clamping Voltage @ Test Current 8/20µs		Typical Capacitance @1KHZ 25°C			
	AC RMS Volts	DC Volts	Energy 10/1000µs Jules	8/20µs Peak				Min Volts	Max Volts	Volts	Amps	PF		
				Lead 1-2 or 2-3		Lead 1-3								
			1 time Kamps	2 times Kamps	1 time Kamps	2 times Kamps						mm	mm	
SR201K34RD□	130	175	310	40	25	80	50	185	225	340	300	7900	9.1	4.1±1.0
SR221K34RD□	140	180	330	40	25	80	50	198	242	360	300	7200	9.2	4.2±1.0
SR241K34RD□	150	200	360	40	25	80	50	216	264	395	300	6600	9.3	4.6±1.0
SR271K34RD□	180	230	390	40	25	80	50	255	311	455	300	5600	9.5	4.8±1.0
SR301K34RD□	195	250	405	40	25	80	50	270	330	505	300	5200	10.5	5.2±1.0
SR331K34RD□	210	275	430	40	25	80	50	297	363	550	300	4800	11.3	5.4±1.0
SR361K34RD□	230	300	460	40	25	80	50	324	396	595	300	4400	11.5	5.8±1.0
SR391K34RD□	250	330	490	40	25	80	50	351	429	650	300	4100	11.6	6.2±1.0
SR431K34RD□	275	370	550	40	25	80	50	387	473	710	300	3800	11.9	6.5±1.0
SR471K34RD□	300	385	600	40	25	80	50	423	517	775	300	3400	12.8	6.9±1.0
SR511K34RD□	320	420	640	40	25	80	50	459	561	840	300	3200	13.1	7.2±1.0
SR561K34RD□	360	470	710	40	25	80	50	522	638	910	300	2700	13.4	7.7±1.0
SR621K34RD□	390	505	800	40	25	80	50	558	682	1025	300	2600	13.6	8.2±1.0
SR681K34RD□	420	560	910	40	25	80	50	612	748	1120	300	2400	13.9	8.8±1.0
SR751K34RD□	460	615	980	40	25	80	50	675	825	1240	300	2200	15.3	9.3±1.0
SR781K34RD□	485	640	1020	40	25	80	50	702	858	1290	300	2100	15.5	9.6±1.0
SR821K34RD□	510	675	1100	40	25	80	50	738	902	1355	300	2000	15.5	10.1±1.0
SR911K34RD□	550	745	1150	40	25	80	50	819	1001	1500	300	1800	17.0	11.1±1.0
SR951K34RD□	575	765	1200	40	25	80	50	855	1045	1570	300	1700	17.2	11.3±1.0
SR102K34RD□	625	825	1250	40	25	80	50	900	1100	1650	300	1600	18.0	11.8±1.0
SR112K34RD□	680	895	1350	40	25	80	50	962	1175	1815	300	1500	18.6	13.0±1.0

□ - Part Number Suffix Code (ie: SR201K34RDQ)

No suffix - Straight Lead

Q - 90° Bend Lead

UL 1449 recognized (File # E309297)

cUL (CSA 22.2 #1 certified, File # E309297)

Straight Leads Part Number No Suffix

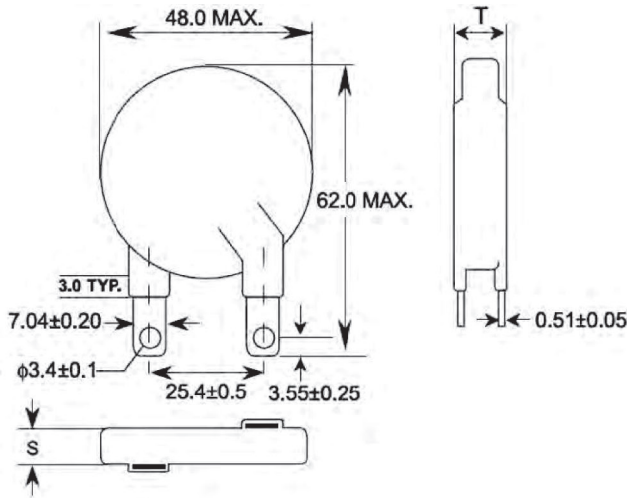

90° Bend Leads Part Number Suffix "Q"

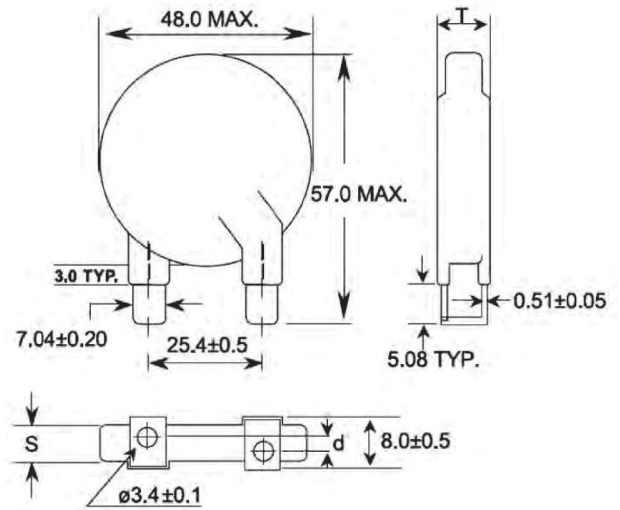

Part Number	Maximum Ratings					Electrical Characteristics					Tmax.	s	d
	Continuous Rated Voltage		Rated Single Pulse Transient			Varistor Voltage @ 1mA DC		Maximum Clamping Voltage @ Test Current 8/20µs		Typical Capacitance @1KHZ 25°C			
	AC RMS Volts	DC Volts	Energy	8/20µs Peak		Min Volts	Max Volts	Volts	Amps	PF			
			10/1000µs Jules	1 time Kamps	2 times Kamps								
SR201K40D□	130	175	310	40	25	185	225	340	300	10000	7.5	2.5±1.0	5.7±1.0
SR221K40D□	140	180	330	40	25	198	242	360	300	9000	7.5	2.5±1.0	5.5±1.0
SR241K40D□	150	200	360	40	25	216	264	395	300	8000	7.5	2.8±1.0	5.4±1.0
SR271K40D□	180	230	390	40	25	255	311	455	300	7100	8.5	2.8±1.0	5.2±1.0
SR331K40D□	210	275	460	40	25	297	363	550	300	6000	9.0	3.1±1.0	4.8±1.0
SR361K40D□	230	300	475	40	25	324	396	595	300	5600	9.0	3.3±1.0	4.6±1.0
SR391K40D□	250	330	490	40	25	351	429	650	300	5000	9.0	3.6±1.0	4.4±1.0
SR431K40D□	275	370	550	40	25	387	473	710	300	4500	9.0	3.6±1.0	4.2±1.0
SR471K40D□	300	385	600	40	25	423	517	775	300	4000	9.7	3.8±1.0	4.2±1.0
SR511K40D□	320	420	640	40	25	459	561	840	300	3800	9.7	3.8±1.0	4.0±1.0
SR621K40D□	390	505	800	40	25	558	682	1025	300	3300	9.7	4.3±1.0	3.9±1.0
SR681K40D□	420	560	910	40	25	612	748	1120	300	3000	9.7	4.6±1.0	3.6±1.0
SR751K40D□	460	615	920	40	25	675	825	1240	300	2600	10.5	4.8±1.0	3.3±1.0
SR781K40D□	485	640	930	40	25	702	858	1290	300	2500	10.5	4.8±1.0	3.1±1.0
SR821K40D□	510	675	940	40	25	738	902	1355	300	2300	10.5	5.1±1.0	2.9±1.0
SR911K40D□	550	745	960	40	25	819	1001	1500	300	2200	11.5	5.6±1.0	2.5±1.0
SR951K40D□	575	765	1000	40	25	855	1043	1570	300	2000	11.5	5.6±1.0	2.3±1.0
SR102K40D□	625	825	1055	40	25	900	1100	1650	300	1900	12.0	5.8±1.0	2.1±1.0
SR112K40D□	680	895	1155	40	25	962	1175	1815	300	1800	12.0	6.4±1.0	2.1±1.0

□ - Part Number Suffix Code (ie: SR201K40DQ)

No suffix - Straight Lead

Q - 90° Bend Lead

F - Un-Coated Disk - with Leads

ML - One Side coated Disk - with one Left Orientation Lead only

NL - Uncoated Disk - with one Left Orientation Lead only

L - Straight Lead - Left Side Lead Orientation

R - Uncoated Disk - without Leads

M - One Side Coated Disk - with one Right Orientation Lead only

N - Uncoated Disk - with one Right Orientation Lead only

UL 1449 recognized (File # E309297)

cUL (CSA 22.2 #1 certified, File # E309297)

Straight Leads Part Number No Suffix

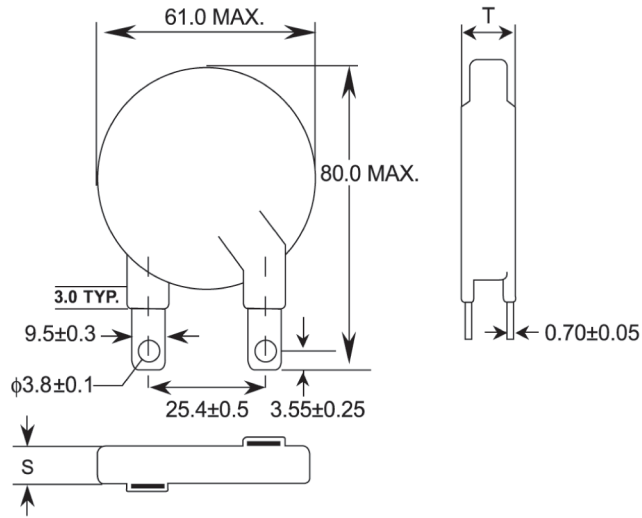

90° Bend Leads Part Number Suffix "Q"

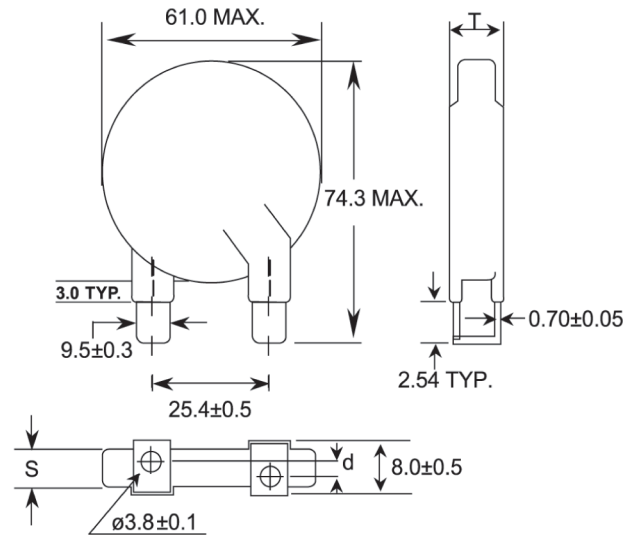

Part Number	Maximum Ratings					Electrical Characteristics					Tmax.	s	d
	Continuous Rated Voltage		Rated Single Pulse Transient			Varistor Voltage @ 1mA DC		Maximum Clamping Voltage @ Test Current 8/20µs		Typical Capacitance @1KHZ 25°C			
	AC RMS Volts	DC Volts	Energy	8/20µs Peak		Min Volts	Max Volts	Volts	Amps	PF			
			10/1000µs Jules	1 time KAmps	2 times KAmps								
SR201K53D□	130	175	490	70	45	185	225	340	500	15000	7.5	2.5±1.0	5.7±1.0
SR221K53D□	140	180	530	70	45	198	242	360	500	13800	7.5	2.5±1.0	5.5±1.0
SR241K53D□	150	200	570	70	45	216	264	395	500	12500	7.5	2.8±1.0	5.4±1.0
SR271K53D□	180	230	630	70	45	255	311	455	500	11000	8.5	2.8±1.0	5.2±1.0
SR331K53D□	210	275	680	70	45	297	363	550	500	9000	9.0	3.1±1.0	4.8±1.0
SR361K53D□	230	300	730	70	45	324	396	595	500	8500	9.0	3.3±1.0	4.6±1.0
SR391K53D□	250	330	880	70	45	351	429	650	500	7500	9.0	3.6±1.0	4.4±1.0
SR431K53D□	275	370	950	70	45	387	473	710	500	7000	9.0	3.6±1.0	4.2±1.0
SR471K53D□	300	385	1000	70	45	423	517	775	500	6500	9.7	3.8±1.0	4.2±1.0
SR511K53D□	320	420	1100	70	45	459	561	840	500	6000	9.7	3.8±1.0	4.0±1.0
SR561K53D□	360	470	1200	70	45	522	638	910	500	5600	9.7	4.3±1.0	4.0±1.0
SR621K53D□	390	505	1300	70	45	558	682	1025	500	5200	9.7	4.3±1.0	3.9±1.0
SR681K53D□	420	560	1500	70	45	612	748	1120	500	4800	9.7	4.6±1.0	3.6±1.0
SR751K53D□	460	615	1600	70	45	675	825	1240	500	4300	10.5	4.6±1.0	3.3±1.0
SR781K53D□	485	640	1650	70	45	702	858	1290	500	3900	10.5	4.8±1.0	3.1±1.0
SR821K53D□	510	675	1800	70	45	738	902	1355	500	3700	10.5	5.1±1.0	2.9±1.0
SR911K53D□	550	745	2000	70	45	819	1001	1500	500	3300	11.5	5.6±1.0	2.5±1.0
SR951K53D□	575	765	2100	70	45	855	1043	1570	500	3200	11.5	5.6±1.0	2.3±1.0
SR102K53D□	625	825	2200	70	45	900	1100	1650	500	3000	11.5	5.8±1.0	2.1±1.0
SR112K53D□	680	895	2500	70	45	962	1175	1815	500	2800	11.5	6.4±1.0	2.1±1.0
SR122K53D□	750	970	2700	70	45	1062	1300	1980	500	2700	12.6	7.0±1.0	1.5±1.0

□ - Part Number Suffix Code (ie: SR201K53DQ)

No suffix - Straight Lead

Q - 90° Bend Lead

F - Un-Coated Disk - with Leads

ML - One Side coated Disk - with one Left Orientation Lead only

NL - Uncoated Disk - with one Left Orientation Lead only

L - Straight Lead - Left Side Lead Orientation

R - Uncoated Disk - without Leads

M - One Side Coated Disk - with one Right Orientation Lead only

N - Uncoated Disk - with one Right Orientation Lead only

UL 1449 recognized (File # E309297)

cUL (CSA 22.2 #1 certified, File # E309297)

V-I Curve for SR201K~431K32D Series

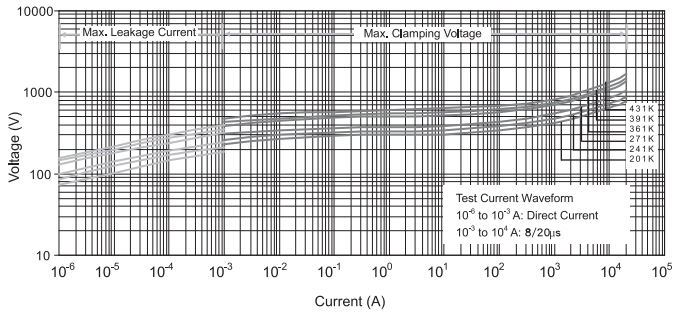

V-I Curve for SR471K~951K32D Series

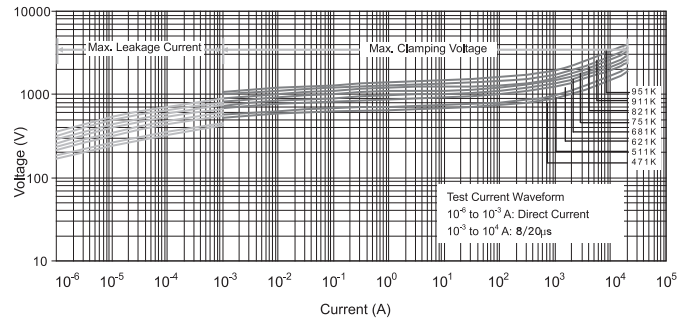

V-I Curve for SR201K~431K34R Series

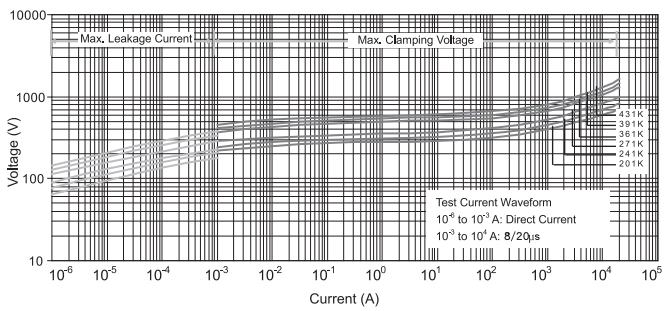

V-I Curve for SR471K~951K34R Series

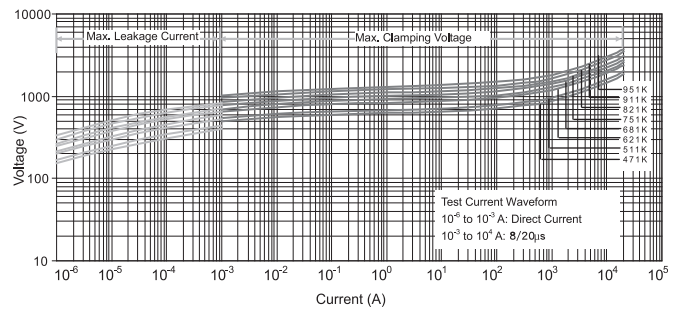

V-I Curve for SR201K~431K40D Series

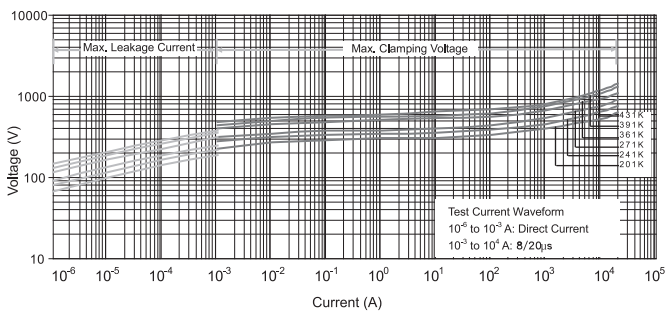

V-I Curve for SR471K~951K40D Series

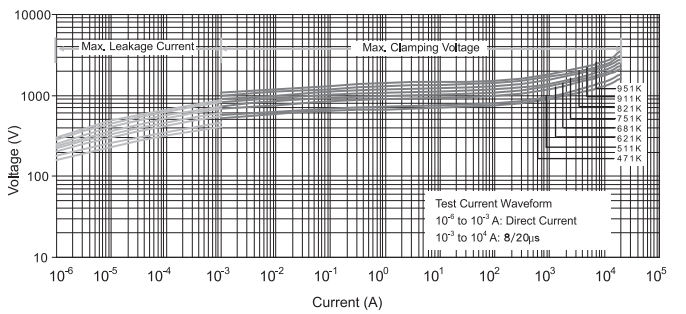

V-I Curve for SR201K~431K53D Series

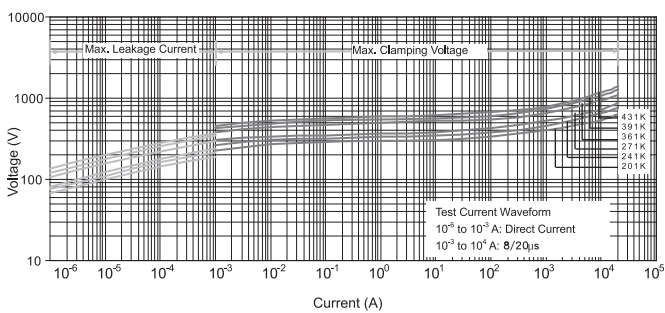

V-I Curve for SR471K~951K53D Series

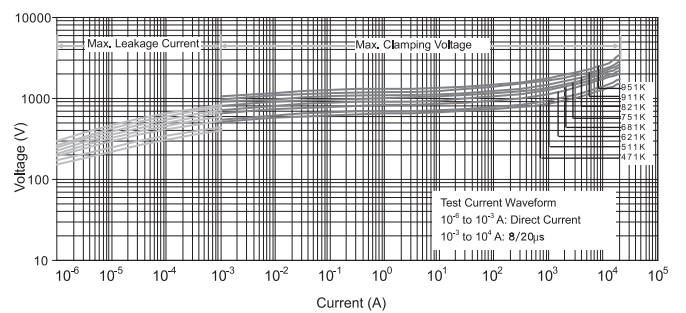

■ Packing Specification of Big MOV (32~53mm)

Disk size mm	Varistor Voltage	Q'ty PCS/BOX	Q'ty PCS/CARTON
32D	201K~391K	80	320
	431K~621K	60	240
	681K~122K	40	160
34R	201K~391K	80	320
	431K~621K	60	240
	681K~122K	40	160
40D	201K~391K	80	320
	431K~621K	60	240
	681K~122K	40	160
53D	201K~391K	80	320
	431K~621K	60	240
	681K~122K	40	160

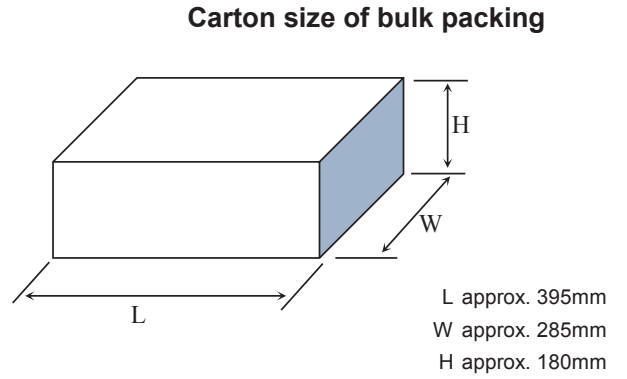

Please consult sales for detail specification

■ Wave Soldering Profile

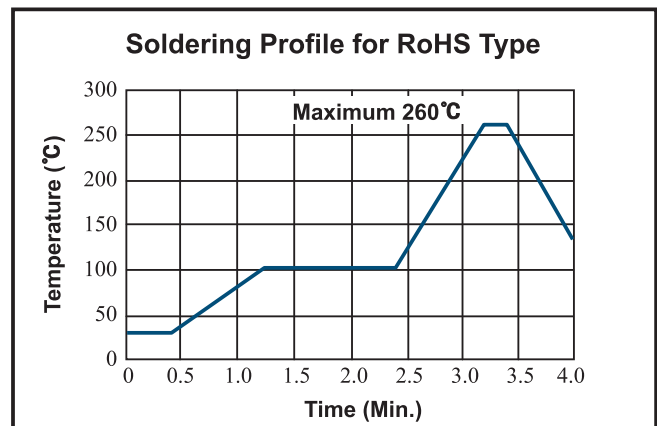
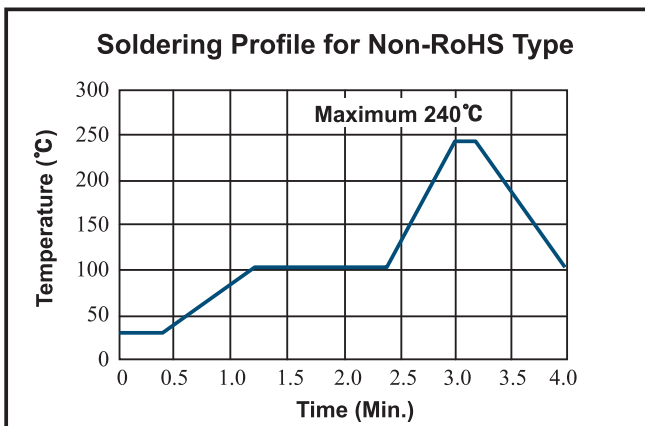

Taiwan - Yang-Mei Plant / Sales Office

Walsin Technology Corporation
566-1, Kao-Shi Road, Yang-Mei, Tao-Yuan, Taiwan
Tel: +886-3-475-8711 Fax: +886-3-475-7130 Email: info@passivecomponent.com

China - Dalang Plant / Sales Office

Dongguan Walsin Tech. Electronics CO., Ltd.
Xiniupo Administrative Zone, Dalang Town, Dongguan City, Guangdong Province 523799
Tel: +86-769-831-15168 Fax: +86-769-831-15188 Email: shchen@passivecomponent.com

China - Suzhou Plant / Sales Office

Suzhou Walsin Technology Electronics Co., Ltd.
No. 369, Changyan Street, Suzhou Industrial Park, Jiangsu Province 215126
Tel: +86-512-628-36888 Fax: +86-512-628-37888 Email: shchen@passivecomponent.com

China - Guangzhou Plant / Sales Office

Pan Overseas (Guangzhou) Electronic Co., Ltd.
No. 277, Hong Ming Road, Eastern Section, Guangzhou Economic and Technology, Development Zone, China
Tel: +86-20-8223-7476 Fax: +86-20-8223-7475 Email: shchen@passivecomponent.com

Germany - Munich Sales Office

Walsin Technology Corporation Europe
Bretonischer Ring 6, Pavillon 3, 85630 Grasbrunn, Germany
Tel: +49-(0)89-9308-6475 Fax: +49-(0)89-9308-6464 Email: aw@passivecomponent.com

Netherlands- Sales Office

Walsin Technology Europe
Westblaak 180, 3012 KN, Rotterdam, the Netherlands
Email: alexysin@passivecomponent.com

Singapore - Sales Office

WTC Singapore Sales Office, Singapore
24 Sin Ming Lane Midview City, #04-100, Singapore 573970
Contact: Morris Liew
Tel: +65-6262 3997 Email: morrisliew@sg.passivecomponent.com

Malaysia - Sales Office

Walsin Technology Corporation, Malaysia
1st Floor, No.19, Jalan Puteri 5/8, Bandar Puteri Puchong, Puchong, 47100, Selangor, Malaysia
Contact: Arthur Ling
Tel: +6016-2217-948 Fax: +603-8051-7060 Email: arthurling@passivecomponent.com

United States - West Coast Sales Office

Walsin Technology Corporation, USA
Contact: FC Tseng
Tel: +1-214-708-5182 E-mail: fctsens@passivecomponent.com

JAPAN - Sales Office

PSA BLDG. 3F, 6-1-6 Chuou, Yamato-Shi, Kanagawa, 242-0021 Japan
Tel: +81-46-204-8806 Fax: +81-46-204-8955 Email: sales@kamaya.co.jp

