



SFI ELECTRONICS TECHNOLOGY INC

# OVER VOLTAGE PROTECTION

ORIGINAL MANUFACTURER



CATALOGUE  
CERAMIC TECHNOLOGY

# Overview

## Content

OVERVIEW

OVERVIEW

### Company Overview

Company Information.....	2
Product Overview.....	3
Over Voltage Pulse Introduction.....	4
Inner Structure & Certification.....	5
Operation Theory & Function Diagram.....	6
Application Fields.....	7
Product Identified .....	8
Surge Definition.....	9
Characteristic Definition.....	10

### CSPD Family

SHV Series(LED Lighting / AC Power).....	12~15
SHA Series(Automotive Application).....	16
SHA Series(Automotive Load Dump Test Standard).....	17
SHA Series(Automotive).....	18~19
SHN Series(Telecom / Ethernet Non-PoE Application).....	20
SHN Series(Telecom / Ethernet with PoE).....	21
SHN Series(Telecom / Ethernet).....	22
SHC Series(Bigger Current).....	23~25
SEA Series(Automotive ESD).....	26
SEH Series(Ultra Low Capacitance).....	27

### SGD Family

SGD Introduction.....	29
STS Series (TVS Diode).....	30
SGD Footprint.....	31
STS Series (TVS General Used).....	32
STA Series (TVS Diode for Automotive) .....	33
STN Series (TVS Diode High Power).....	34
STD Series (Ultra Low capacitance).....	35~37

### MLV Family

A Series(General Used).....	39
C Series(General Used).....	40~41
E Series(General Used / Control Capacitance).....	42~43

### Others

Series size table.....	44~45
------------------------	-------

# Overview

## Company Information



### Introduction

#### SFI

is a professional manufacturer in full range over voltage products in mono-chip, multilayer chip and advanced varistor. We have the largest production capability and production line of the over voltage protection components to supply customer the circuit protection in the world market.

Material : Ceramic & Semi-conductor  
Termination : Nickel Barrier (Ag/Ni/Sn)  
Size Ceramic : 0201~6050 (inch)  
Size Semi-conductor : 0201~0603(inch)  
Meet RoHS compliant.  
Certification :  
ISO9001:2015  
ISO14001: 2015  
IATF16949 :2016  
ISO14064-1:2018



Technischer  
Überwachungsverein  
File No.B101736 0001



Underwriters  
Laboratories

File No.:E334409



#### Advanced Techniques Applied

In order to meet the market trend and fast market change, we build our R&D team to control reliability and stability of the products. We have been utilizing the advanced material and manufacturing techniques on producing the electronic elements and parts. In Taiwan, we are the first company to launch the Zinc Oxide based Ceramic Semiconductor devices with full range and with the highly advanced multilayer formation technologies to apply the high density circuit assemblies. We obtained many kinds of patents for excellent product designs.

SFI's Varistors with high reliability can protect the electronics systems from over voltages by limited surge voltages and absorbing energy. They are used to safeguard the components to ensure more electromagnetic compatibility and to suppress transients caused by electrostatic discharge. In other words, they have the added advantage of greater surge current and energy handling capabilities as well as EMI / RFI attenuation.

SFI's Varistors have established themselves as a secure and low-cost means of protection in general-purpose use.



# Overview

## Product Overview

### Series Table

Type	Transient	Series	Main Application	Standard	Max. Value Parameter	Remark
General	Surge/ESD	MLV-C MLV-A	All	IEC61000-4-5 IEC61000-4-2	Basic	
	ESD	MLV-E	ALL	IEC61000-4-2	ESD 8KV/15KV	
Enhance	Load Dump	SHA	Auto Power ECU	ISO7637-2 Pulse 5 ISO16750	Load Dump 160J	Can replace TVS ,MOV
	Surge	SHC	Industrial Control	IEC61000-4-5	Surge Current : 20KA (8/20 μs)	Can replace MOV , MLV
		SHN	Network Security	IEC61000-4-5 K21	Surge Voltage : 4~8KV (10/700 μs)	Can replace GDT, Sidactor
		SHV SHR (Ring Wave)	LED Lighting Power	IEC61000-4-5 IEC61000-4-12	Breakdown Voltage : 470V / Surge : 100~3000A	Can replace MOV, GDT
New Design	ESD	SEA	Auto CAN BUS	ISO10605 ISO7637-2 Pulse 1, 2, 3	ESD 30KV	Can replace TVS
		TVS(STA)	Auto CAN BUS	ISO10605	ESD 30KV	Can replace TVS
		TVS(STS)	Mobile	IEC61000-4-2	Clamping Voltage <12.5V	Can replace TVS
		TVS(STN)	Telecom Ethernet (PHY Sided)		ESD 15KV L-L 2KV/40 ohm	Can replace TVS
		TVS(STD)	High Speed		ESD 15KV	Can replace TVS
		SEH	Ultra High Speed		Breakdown voltage : 100V / Cap. 0.2pF	Can replace TVS
Ultra Low Capacita nce	ESD	STD	Fast Transmitting	IEC61000-4-2	ESD 30 KV Cap. 0.05 pF	Can replace TVS

(\*) Remark : Dual function products are under developing

# Overview

## Over Voltage Pulse Introduction

### Environment

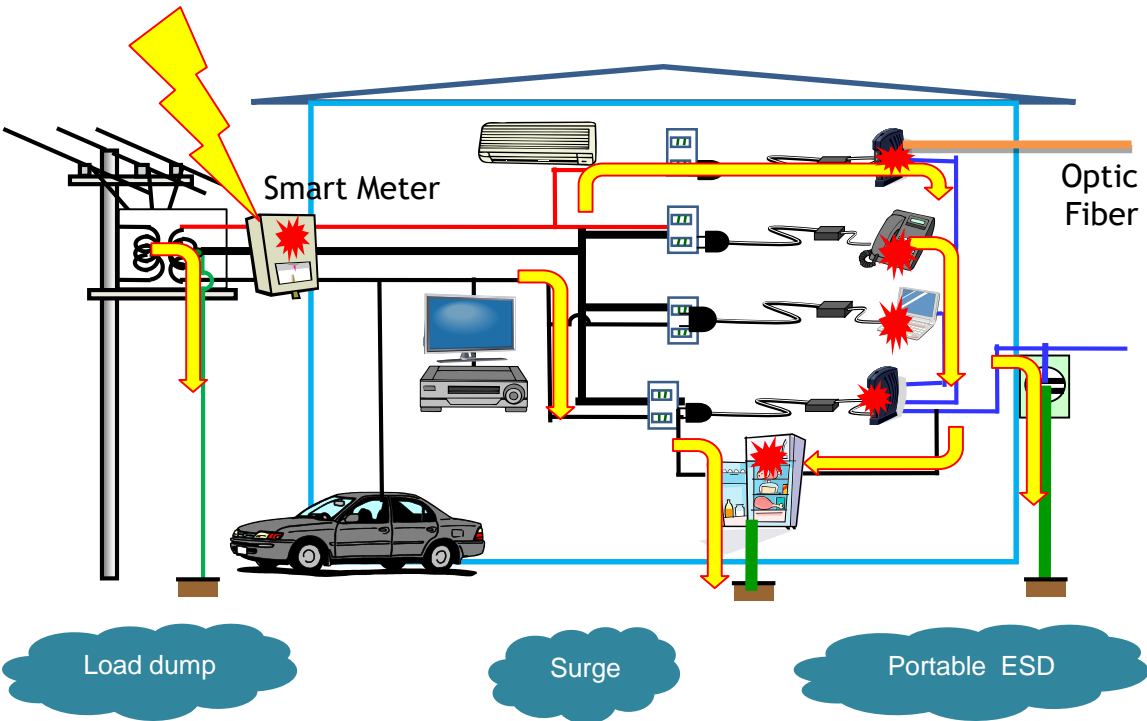

### Energy vs Time

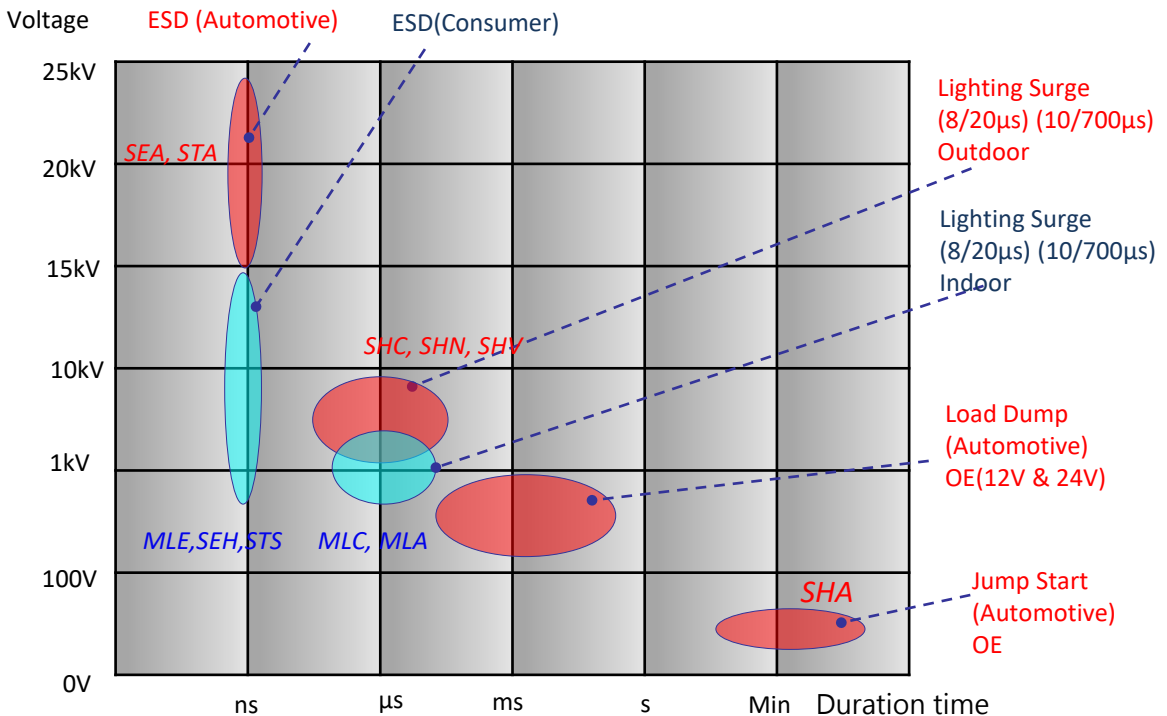



# Overview

## Inner Structure & Certification

### Multilayer Inner Structure

Multilayer Surface Mount Varistors are made from semi-conducting ceramics by highly advanced multilayer formation technologies, which could offer strong protection, excellent transient energy absorption and internal heat dissipation. The devices are chip form without leads. Eliminating lead inductance and guaranteeing a faster speed response time of less than 0.5ns, which make them fast enough to ensure reliable protection against ESD pulse and other specific transient events. These transient suppression devices are significantly smaller footprints and lower profiles than traditional zener diodes or radial MOVs.

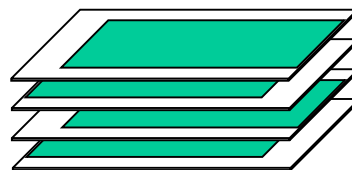

Multilayer formation technologies

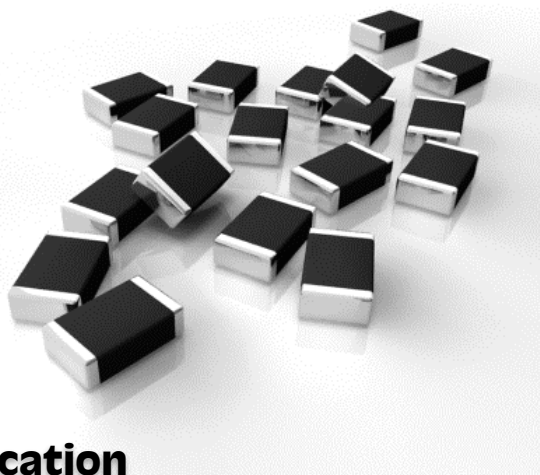
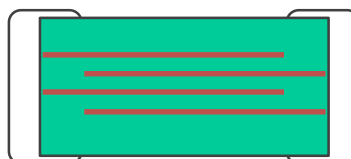
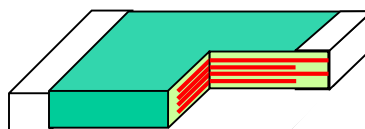

### Certification



A. ISO 9001 : 2015



B. ISO 14001 : 2015



C. IATF 16949-2016

# Overview

## Operation Theory & Function Diagram

### Voltage Dependent Characteristic

Transient voltage suppressors (Varistors) are voltage-dependent electrical resistors with symmetrical V/I characteristic and breakdown region. Their resistance value decreases with increasing voltage, and thus “short-circuiting” further rises in over voltage.

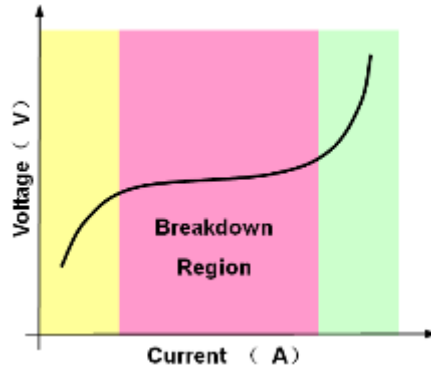

### The Prevention Over Voltage

In other words, as long as the voltage increases above the threshold of the Transient voltage suppressors, the suppressor will draw a rapidly increasing current; then the over voltage is considerably attenuated away from the protected circuit, that is why the inherent protection of equipment should be supplemented by including specific components which will raise the withstand capabilities to required level. Varistors provide protection against all kinds of over voltage and prevent electronic equipment from being damaged by transient events.

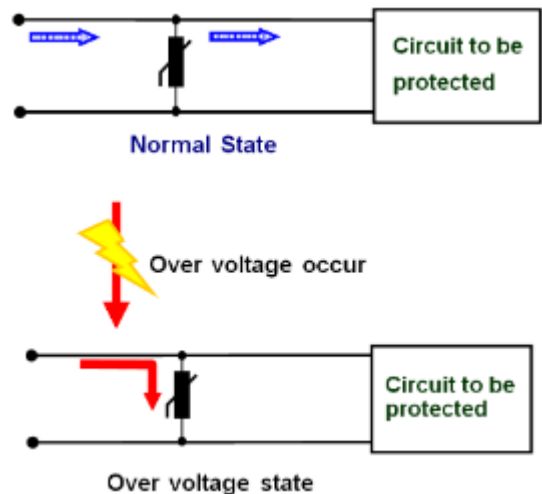

### The Function Diagram

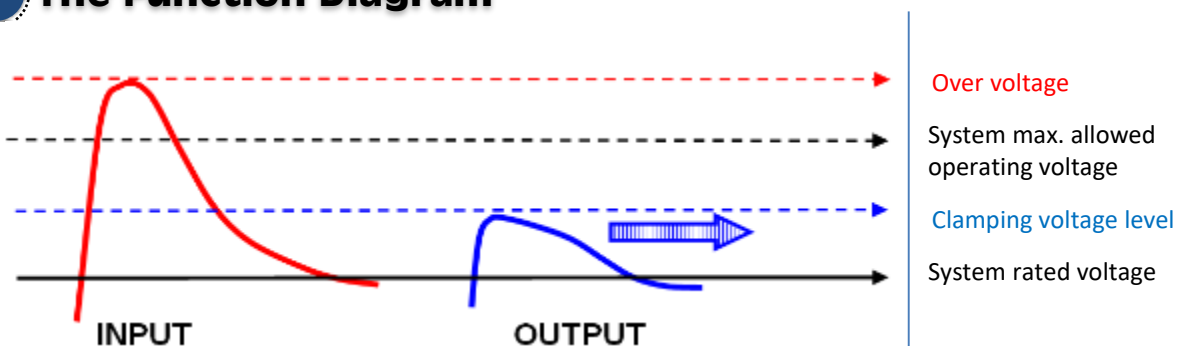

# Overview

## Application Filed

OVERVIEW

OVERVIEW

### Multilayer Inner Structure



### Suggestion Table

	Issue	SHA	SHC	SHV/R	SHN	SEA	MLE	SEH	STS	STA	STN	STD	MLC/A
Automotive	Load Dump/ESD	V				V				V			V
Industry & IP Cam	Surge / ESD		V		V		V	V	V		V		V
Telecom & I cloud	Surge/ESD		V		V		V	V	V		V		V
Consumer & Computer	ESD						V	V	V				V
Mobile	ESD						V	V	V				
LED Lighting	Surge/ESD/ Ring		V	V			V						
Ultra Fast Transmitted	ESD											V	



# Overview

## Product Identified

### Ceramic CSPD Family

Series	Function	Character	Application
SHN	Surge	Size (Inch) : 0805~1812 Breakdown Voltage : 12V~75V Surge Voltage : 1.5KV~8KV(10/700μs)	Telecom Equipment Ex : Ethernet 、 PoE 、 Hub 、 Router 、 RJ45 Connector
SHC	Surge	Size (Inch) : 0805~4032 Breakdown Voltage : 12V~100V Surge Current : 250A~20KA(8/20 μs)	DC Power Ex : DC 、 Low voltage AC 、 Base Station
SHA SEA	Load Dump ESD	Size (Inch) : 0402~0805(ESD Auto) Size (Inch) : 0805~6050(Load Dump) Working Voltage : 12V~60V Load Dump : 1.5J~300J(Pulse 5A) ESD robustness : 25KV	Automotive Ex : All ECU 、 CAN Bus 、 other Control I/O
SHV	Surge	Size (Inch) : 0604~3220 Breakdown Voltage : 170V~680V Surge Current : 20A~3000A(8/20μs)	AC Power Ex : LED Lamp 、 others
SHR	Ring Wave	Size (Inch) : 0604 Breakdown Voltage : 270V Ring Wave : 2.5KV	LED Power Ex : LED DOB
SEH	ESD	Size (Inch) : 0402~0603 Working Voltage : 5V~24V Surge Current : 5A~10A(8/20μs) Capacitance : 0.2pF	Ultra high speed protection Ex : Antenna 、 HDMI 、 DP 、 USB3.0

### Semiconductor SGD Family

Series	Function	Character	Application
STS	ESD	Size (Inch) : 0201~0603 Working Voltage : 3.3V~12V Surge Current : 3A~18A(8/20μs) Capacitance : 0.3 pF~30pF	Normal I/O protection Ex : Video 、 Audio 、 DVI 、 USB2.0/USB3.0
STN	ESD Line to Line (10/700us)	Size (Inch) : 0402 Working Voltage : 5V Surge Current : 7A~15A(8/20μs) Capacitance : 0.8pF~1.5pF	Signal speed Ex : Ethernet 、 USB2.0
STA	ESD	Size (Inch) : 0402~0603 Working Voltage : 3.3V~12V Surge Current : 3A~8A(8/20μs) Capacitance : 0.35pF~17pF	Auto ECU control line Ex : Data line
STD	ESD	Size (Inch) : 0201~0603 Working Voltage : 6V~24V ESD ability : ±15KV(contact) ; ±25KV(air) Capacitance : 0.05pF	Speed line Ex : USB 3.1 、 Ethernet 10G 、 Wifi 6

### Ceramic MLV Family

Series	Function	Character	Application
ML MLA	ESD Surge	Size (Inch) : 0402~2220 Working Voltage : 5V~82V Surge Current : 20A~1200A(8/20μs)	Normal I/O protection Ex : Video 、 Audio 、 DVI 、 USB2.0
MLE	ESD	Size (Inch) : 0201~0805 Working Voltage : 5V~24V Surge Current : 5A~10A(8/20μs) Capacitance : 0.8pF~100pF	Signal speed Ex : Video 、 Audio 、 DVI 、 VGA 、 USB2.0 、 D-DUB

# Overview

## Surge Definition

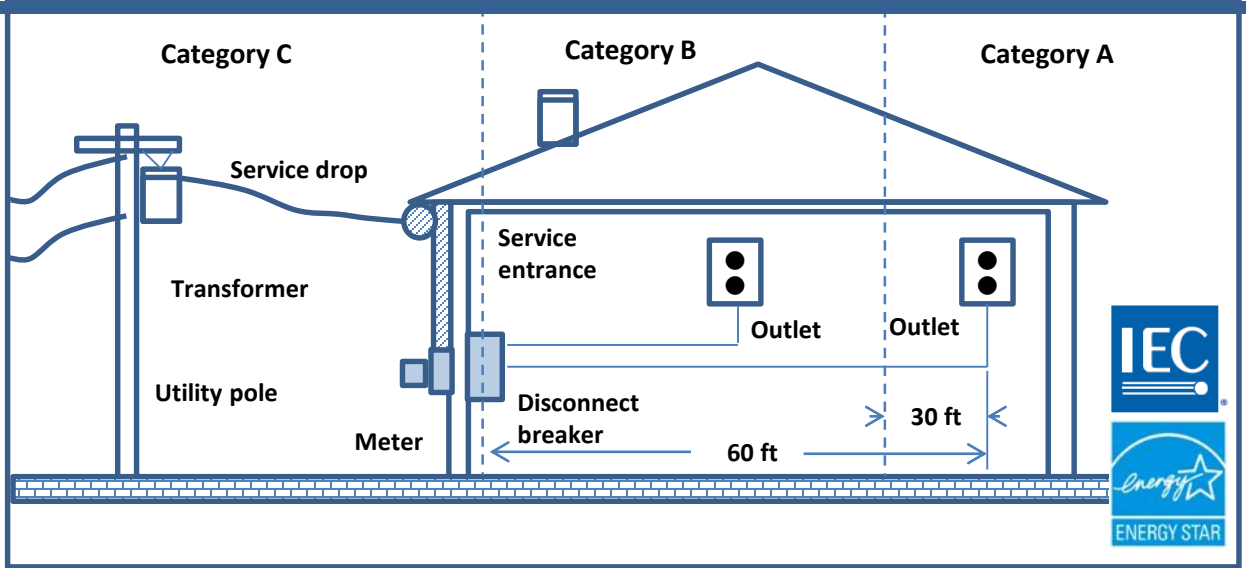

Category C : Service entrance, more severe environment : 10KV, 10KA surge.

Category B : Downstream, 30 ft from category C, less severe environment : 6KV, 3KA surge.

Category A : Further downstream, 60 ft from category C, least severe environment : 6KV, 0.5KA surge.

Category	Voltage 1.2/50 $\mu$ s	Current 8/20 $\mu$ s	Impedance $\Omega$	Application
C(Outdoor)	6KV	3KA	2	Outdoor Commercial , Industrial / Parking
B	6KV	3KA	2	Lighting near Service Entrance
A(Indoor)	6KV	0.5KA	12	Indoor /Offices/ Retail

	United States	Europe / America	Taiwan	China
Surge Immunity 1.2/50 $\mu$ s and 8/20 $\mu$ s LED light bulbs inside	IEEE62.41.2 Ring wave 2.5KV 100KHz Class A	IEC/EN61547 (IEC61000-4-5) 500V/250A,1KV/500A	CNS14676-5 (IEC/EN61000-4-5) 500V/250A 1KV/500A	GB/T18595 (IEC/EN61547) 500V/250A 1KV/500A
Surge Immunity 1.2/50 $\mu$ s and 8/20 $\mu$ s LED outdoor Luminaires	IEEE62.41.2 (Category C) 6KV/3KA 20KV/10KA	IEC/EN61547 IEC/EN61000-4-5 4KV/2KA, 6KV/3KA, 10KV/5KA	IEC/EN61000-4-5 4KV/2KA	IEC/EN61000-4-5 4KV/2KA
Safety	UL8750, UL1310 UL1993, UL1598	IEC/EN62560,IEC/EN60598 IEC/EN61347,IEC/EN62031	CNS STD.	GB24819-2009 IEC62031

Character	Test Level		
	Device		
	Self-ballasted Lamp & Semi-luminaries	Luminaries & independent auxiliaries	
		< =25W	> 25W
Surge waveform	1.2/50 $\mu$ s	1.2/50 $\mu$ s	1.2/50 $\mu$ s
Line to Line	1.0KV	1.0KV	1.0KV
Line to Ground	1.0KV	1.0KV	2.0KV

# Overview

## Characteristic Definition

Characteristic Definition Characteristics	Test Method or Description
Max. Working Voltage	Maximum steady-state DC operating voltage the device can maintain and typical leakage current at 25°C not exceed 50 μA.
Varistor Voltage (BDV)	With the specified measuring current of 1mA DC applied. Tolerance of breakdown voltage : 5~8V= ±20%; 12~18V= ±15%; 18~430V= ±10%
Max. Clamping Voltage	Maximum peak voltage across the TVS measured at a specified pulse current (A) and waveform 8/20μs.
Surge Current	Maximum peak current within Varistor voltage change of ±10% may be applied with the specified waveform 8/20μs.
Surge Shift ΔV/V	The shift of Varistor voltage after suffering the specified surge current.
Energy Absorption	Maximum energy within the Varistor voltage change of ±10% may be dissipated with a specified waveform 10/1000μs.
Typical Capacitance	Device Capacitance measured with the zero voltage bias 0.5V <sub>RMS</sub> 1KHz; under 100pF measure at 1MHz; Surge series the capacitance is only for reference. The tolerance is 100%
Nonlinear exponent α	$\alpha = [ \log ( V_{1mA} / V_{0.1mA} ) / \log ( I_{1mA} / I_{0.1mA} ) ]$
Leakage Current	Typical leakage current at 25°C < 50μA; Maximum leakage 200μA
Cut-off Frequency	It is named of cut-off frequency for the frequency of -3dB insertion loss.

※Standard Test Condition :

Environmental condition under which every measuring is done without doubt on the measuring results. Unless specially specified, temperature, relative humidity are 5 to 35°C, 45 to 85 % RH.

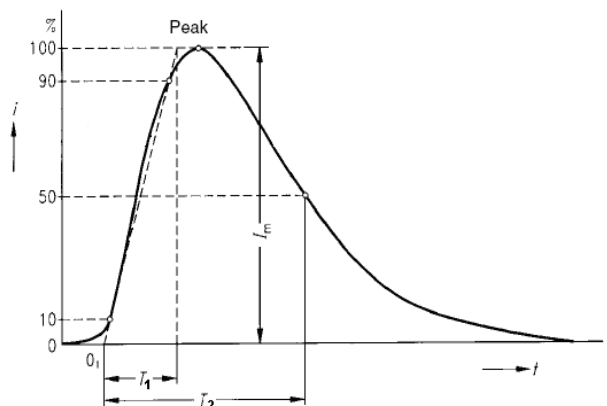
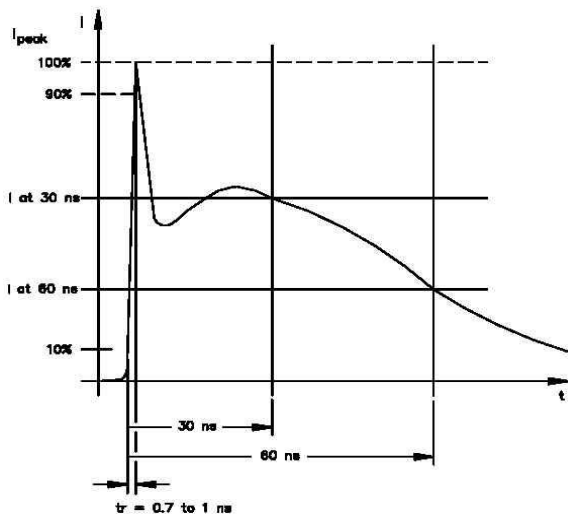

※ 8/20μs waveform current (A)

※ 10/700μs waveform current (V)

※ IEC61000-4-2 ESD protection waveform current  
 ※ ISO10605 ESD Automotive protection waveform current

IEC 61000-4-5, EN 61000-4-5, This generator complies with UL 1449 August 15, 1996 Table B1.1

# CSPD Family

SHV SHR

SHA SEA

SHN

SHC

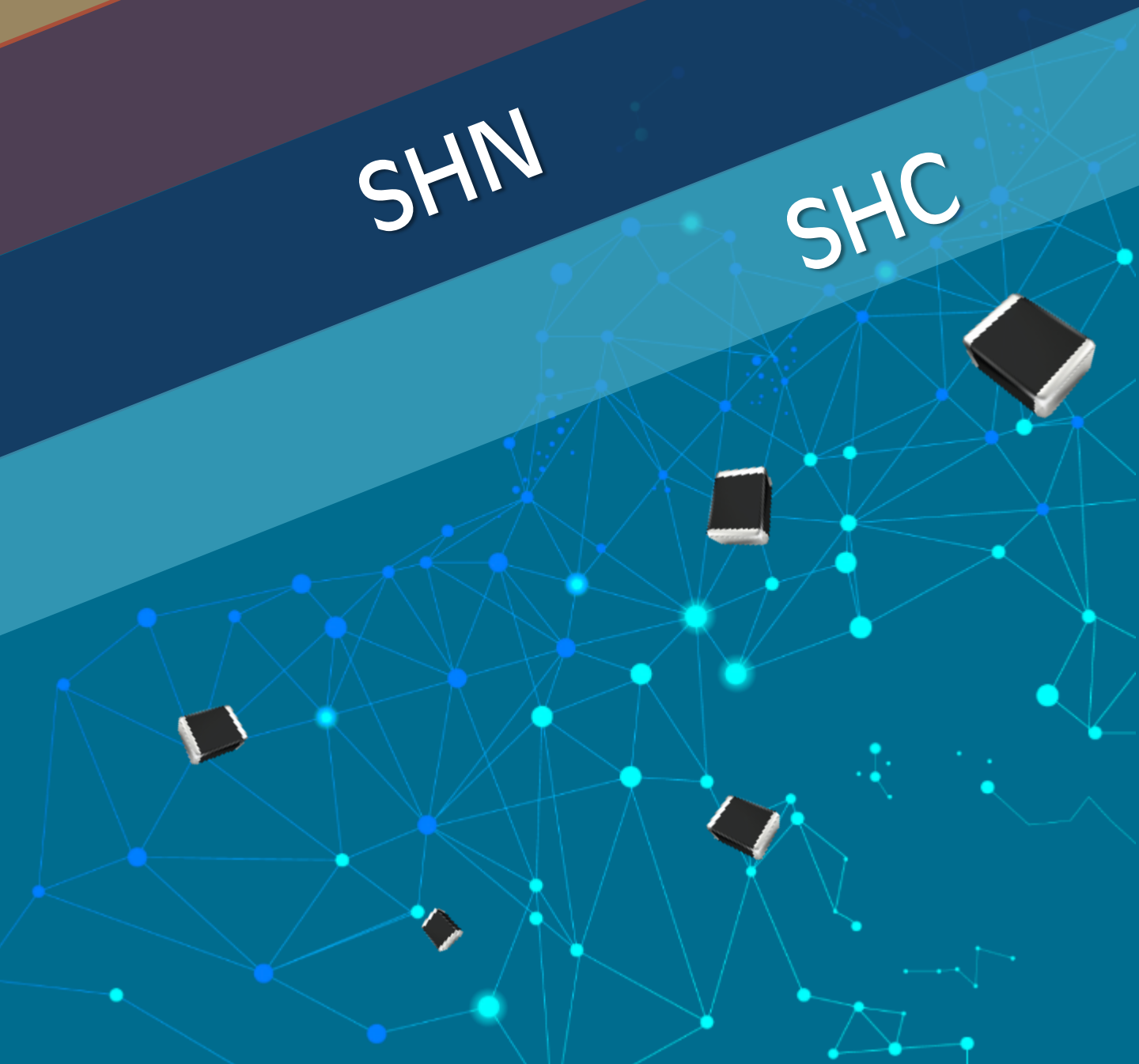

# CSPD Family

CERAMIC

## SHV Series (LED Lighting / AC Power)

CSPD SHV

CSPD SHV

### Requirement

LED Lighting is generally driven in two ways: switch-type drive and linear drive. Although the switch-type drive can obtain good current control accuracy and high overall efficiency, due to production efficiency and application requirements, linear drive applications have gradually become the mainstream in recent years. Most of the traditional LED lighting surge solutions are used. MOV (DIP Varistor) protects, when a surge voltage (flow) occurs, MOV will quickly decrease from high impedance to low impedance, providing a conduction path to conduct energy to the earth, but MOV still has some problems, such as excessive volume. It is not easy to assemble, and the product is more susceptible to cracking.

### Description

SFI has developed a dedicated SHV series of multi-function overvoltage protectors for LED lighting.

**SHV** provides "small size SMD patch" packaging, which is the world's smallest chip package with high collapse pressure and high flow capacity. It has passed UL and TUV certification and has been mass-produced SHV protection components. LED manufacturers use.

### Features

- Size : 0806~3220(Inch)
- Meet : IEC61000-4-5  
1.2/50  $\mu$ s or 8/20  $\mu$ s
- BDV : 170V~680V
- Peak surge : 3000A(max.)
- Operating temperature : 125°C.
- UL 1449 /TUV approval**
- Bi-directional clamping
- SMD package, non-combustible**

### Application Area

-LED Lighting

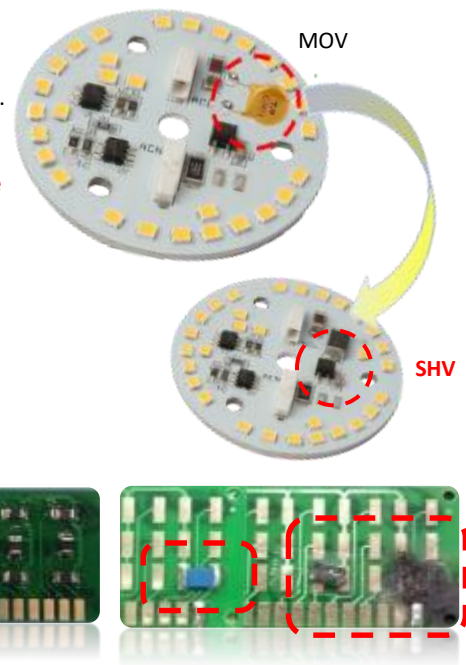

### Reference Application Circuit

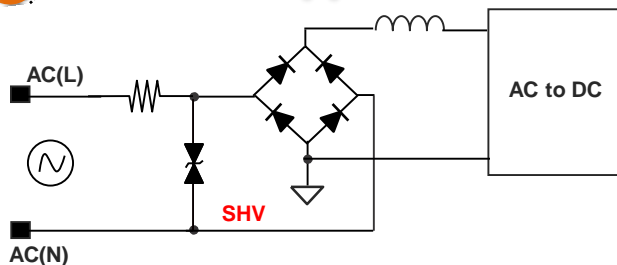

### Comparison with Other Solution

	SFI SHV	LixxxIFxxx	EPXXX
Construction	Displaced electrodes	Displaced electrodes	Plastic encapsulated
Size compare	0806 available(inch)	3220(inch)	3225(inch)
UL test compare (Need pass 15 times)	Pass	Pass	Pass
High temperature	Good	Bad	Bad
High humidity	Good	Bad	Bad
Termination	Ag/Ni/ Sn	Ag/Pt	Tinned copper

The current overvoltage surge protection parts are using plastic epoxy, after thermal shock, products will be degraded and burned. SHV series won't have situation such this.

High humidity and high temperature (Reliable)

After IEC environment test condition at 85°C and high humidity 40°C 95% load test, the variation of BDV is under 10%



# CSPD Family

CERAMIC

SHV Series (LED Lighting / AC Power)

## Specification ( for UL Certification )



All specification is base on datasheets and subject to change without notice.

Size	Part No.	Working Voltage		Breakdown Voltage	Clamping Voltage	Surge Current	Typical Cap.
		V <sub>AC</sub>	V <sub>DC</sub>	V <sub>B</sub> (1mA)	V <sub>C</sub> (max.)	I <sub>peak</sub> (8/20μS)	C(1KHz)
0604	0604SV271-600A	175V	225V	270V (±10%)	450V	60A	40pF
	0604SV431-300A	275V	350V	430V (±10%)	705V	30A	15pF
0806	0806SV241-201A	150V	200V	240V (±10%)	395V	200A	95pF
	0806SV271-101A	175V	225V	270V (±10%)	450V	100A	50pF
1206	1206SV241-351A	150V	200V	240V (±10%)	395V	350A	180pF
1208	1208SV471-401A	300V	385V	470V (±10%)	775V	100A	30pF
1210	1210SV171-251S	95V	135V	170V (±10%)	250V	250A	195pF
	1210SV241-201A	139V	195V	240V (±10%)	395V	200A	110pF
	1210SV271-801A	175V	225V	270V (±10%)	450V	800A	350pF
	1210SV391-201A	250V	320V	390V (±10%)	647V	200A	105pF
	1210SV471-251A	300V	385V	470V (±10%)	775V	250A	100pF
	1210SV471-401A	300V	385V	470V (±10%)	775V	400A	160pF
1812	1812SV271-102A	175V	225V	270V (±10%)	450V	1000A	600pF
	1812SV271-501A	175V	225V	270V (±10%)	450V	500A	275pF
	1812SV511-501A	315V	410V	510V (±10%)	845V	500A	220pF
	1812SV511-801A	315V	410V	510V (±10%)	845V	800A	330pF
2220	2220SV241-801A	139V	195V	240V (±10%)	395V	800A	430pF
	2220SV271-501A	175V	225V	270V (±10%)	450V	500A	390pF
	2220SV391-501A	250V	320V	390V (±10%)	647V	500A	235pF
	2220SV391-801A	250V	320V	390V (±10%)	647V	800A	320pF
3220	3220SV271-801A	175V	225V	270V (±10%)	450V	1000A	550pF
	3220SV431-801A	275V	350V	430V (±10%)	705V	1000A	490pF
	3220SV471-801A	300V	385V	470V (±10%)	775V	1000A	450pF
	3220SV681-102A	420V	560V	680V (±10%)	1120V	1000A	1300pF

CSPD SHV

CSPD SHV

# CSPD Family

CERAMIC

SHV Series (LED Lighting / AC Power)

CSPD SHV

CSPD SHV

## Specification ( for TUV Certification )



All specification is base on datasheets and subject to change without notice.

Size	Part No.	Working Voltage		Breakdown Voltage	Clamping Voltage	Surge Current	Typical Cap.
		V <sub>AC</sub>	V <sub>DC</sub>	V <sub>B</sub> (1mA)	V <sub>c</sub> (max.)	I <sub>peak</sub> (8/20μS)	C(1KHz)
0806	0806SV511-700A	315V	410V	510V (±10%)	845V	70A	20pF
1206	1206SV471-201A	300V	385V	470V (±10%)	775V	200A	55pF
1210	1210SV431-501A	275V	350V	430V (±10%)	705V	500A	200pF

## SHV-UL + TUV Series Specification



All specification is base on datasheets and subject to change without notice.

Size	Part No.	Working Voltage		Breakdown Voltage	Clamping Voltage	Surge Current	Typical Cap.
		V <sub>AC</sub>	V <sub>DC</sub>	V <sub>B</sub> (1mA)	V <sub>c</sub> (max.)	I <sub>peak</sub> (8/20μS)	C(1KHz)
0806	0806SV431-101A	275V	350V	430V (±10%)	705V	100A	45pF
1206	1206SV431-201A	275V	350V	430V (±10%)	705V	200A	60pF
	1206SV471-101A	300V	385V	470V (±10%)	775V	100A	30pF
	1206SV511-101A	315V	410V	510V (±10%)	845V	100A	35pF
1210	1210SV471-501A	300V	385V	470V (±10%)	775V	500A	190pF
	1210SV511-351A	315V	410V	510V (±10%)	845V	350A	12pF
1812	1812SV431-801A	275V	350V	430V (±10%)	705V	800A	340pF
	1812SV471-501A	300V	385V	470V (±10%)	775V	500A	200pF
	1812SV471-801A	300V	385V	470V (±10%)	775V	800A	310pF
2220	2220SV431-501A	275V	350V	430V (±10%)	705V	500A	215pF
	2220SV431-801A	275V	350V	430V (±10%)	705V	800A	305pF
	2220SV471-501A	300V	385V	470V (±10%)	775V	500A	195pF
	2220SV471-801A	300V	385V	470V (±10%)	775V	800A	290pF

# CSPD Family

CERAMIC

SHV Series (LED Lighting / AC Power)



## Specification

All specification is base on datasheets and subject to change without notice.

CSPD SHV

CSPD SHV

Size	Part No.	Working Voltage		Breakdown Voltage	Clamping Voltage	Surge Current	Typical Cap.
		V <sub>AC</sub>	V <sub>DC</sub>	V <sub>B</sub> (1mA)	V <sub>C</sub> (max.)	I <sub>peak</sub> (8/20μS)	C(1KHz)
0806	0806SV391-101A	250V	320V	390V (±10%)	565V	100A	40pF
	0806SV471-500A	300V	385V	470V (±10%)	775V	50A	15pF
1206	1206SV151-181A	95V	125V	150V (±10%)	220V	180A	110pF
	1206SV391-101A	250V	320V	390V (±10%)	647V	100A	40pF
1812	1812SV271-202A	175V	225V	270V (±10%)	450V	2000A	860pF
	1812SV471-102A	300V	385V	470V (±10%)	775V	1000A	300pF
2220	2220SV271-801A	175V	225V	270V (±10%)	450V	800A	350pF
	2220SV471-182A	300V	385V	470V (±10%)	775V	1800A	600pF
	2220SV681-801A	420V	560V	680V (±10%)	1120V	800A	210pF
3220	3220SV271-302A	175V	225V	270V (±10%)	450V	3000A	1700pF
	3220SV271-352A	175V	225V	270V (±10%)	450V	3500A	2000pF
	3220SV271-501A	175V	225V	270V (±10%)	450V	500A	340pF
	3220SV271-502A	175V	225V	270V (±10%)	450V	5000A	2150pF
	3220SV471-302A	300V	385V	470V (±10%)	775V	3000A	750pF
	3220SV471-501A	300V	385V	470V (±10%)	775V	500A	290pF
	3220SV511-252A	315V	410V	510V (±10%)	845V	2500A	600pF



## SHR Series Specification

All specification is base on datasheets and subject to change without notice.

Size	Part No.	Working Voltage		Breakdown Voltage	Clamping Voltage	Ring wave voltage (@30Ω)	Typical Cap.
		V <sub>AC</sub>	V <sub>DC</sub>	V <sub>B</sub> (1mA)	V <sub>C</sub> (max.)	V <sub>Ring wave</sub>	C(1KHz)
0604	0604SR271-2R5K	175V	225V	270V (±10%)	450V	2.5KV	20pF

# CSPD Family

CERAMAIC

## SHA Series (Automotive Application)

CSPD SHA

CSPD SHA

### Requirement

Automotive electronics require safety certification. Currently, the car manufacturer must pass the ISO7637 pulse 5a test, the so-called Load dump test. Because this specification has a so-called destructive experimental wave, the reason for this regulation is because when the car starts, the engine Drive the battery to the battery, and then use the 12V or 24V power supply from the electric cigarette lighter to use the electronic products in the car. Once the car electronics are off, the engine will directly charge the car's electronic products, which will cause fire or safety hazard. Car manufacturers have demanded that automotive electronics require the adoption of this regulation.



### Description

SHA series special for worst environment design, for customer to choice operating temperature, it also meet **AEC-Q200** requirement, This type have several advantages, technology for multilayer to provide large **surface area** and **small size**, for mostly application **replace bigger** surface TVS diode. Besides, this series have more wide operating than zener diode. SHA automotive zener diode using **Nano glass technology coating** , no need plastic cover and also **smallest**

### Features

- Size : 0806~4032 (Inch)
- Meet STD : ISO7637/ISO16750 Pulse5A/B
- BDV : 24V~75V
- Load Dump : 1.5J~160J
- Operating temperature : 125°C
- Meet AECQ 200/ PPAP
- Bi-directional clamping
- IATF 16949

### Application Area

- All ECU DC Power
- ADAS
- Car Lighting
- Multi-Media System
- GPS Navigator
- T-Box
- OBU

### Comparison with Other Solution

General (Load Dump) solution :

- 1.Using MOV (Disk Varistor), after thermal shock -40 ~ 90°C/72hr, the surface will be broken. This is caused by Epoxy not withstand high temperature and will burn after continuous using. (Figure 1)
- 2.Test TVS axial type, the part is broken. (Figure 2)
- 3.Test TVS SMD type, it will be peeled off at terminals.(Figure 3)



Figure1

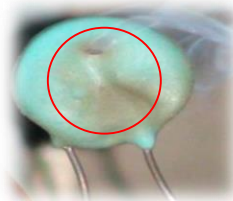

Figure 2

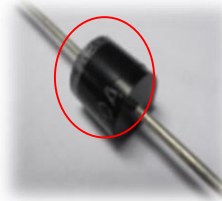
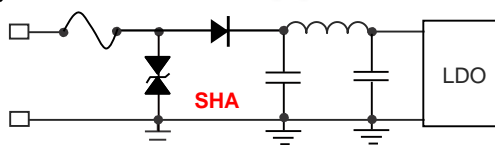
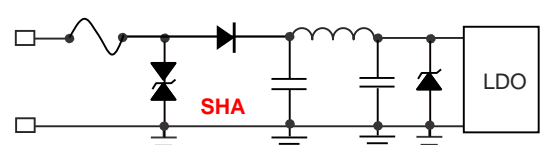

Figure 3

### Reference Application Circuit



The single Stage Load Dump Protection Application for 12 V system



The twice Stages Load Dump Protection Application for 24 V system (Due to Clamping Voltage issue)



# CSPD Family

CERAMAIC

## SHA Series (Automotive Load Dump Test STD.)

CSPD SHA

CSPD SHA

### ISO 7637-2 Pulse 5A/5B

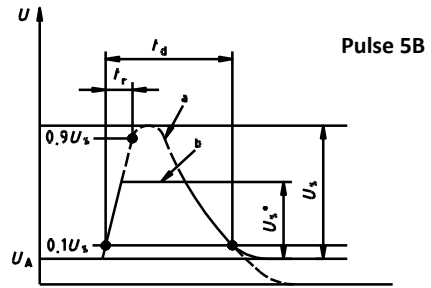
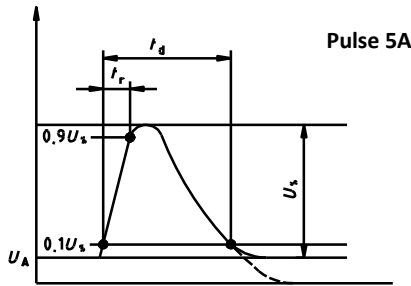

	12V	24V
U <sub>s</sub>	65V~87V	123V~174V
R <sub>i</sub>	0.5Ω~4Ω	1Ω~8Ω
t <sub>d</sub>	40ms~400 ms	100ms~350 ms
t <sub>r</sub>	(10 +0/-5 )ms	

	12V	24V
U <sub>s</sub>	65V~87V	123V~174V
U <sub>s</sub> *	Defined by Customer	
t <sub>d</sub>	Same as 5A	

### ISO 16750-2 Test A/B

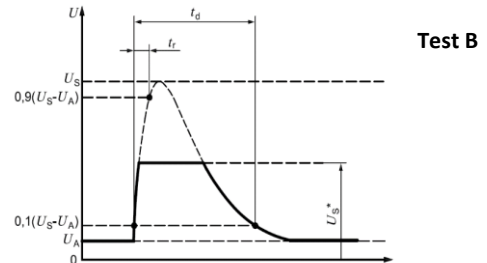
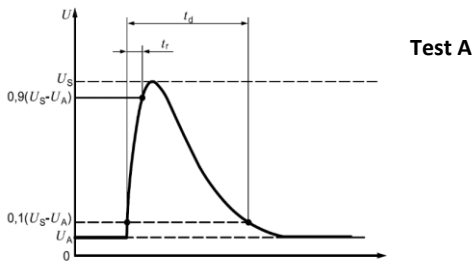

	12V	24V
U <sub>s</sub>	79V~101V	151V~202V
R <sub>i</sub>	0.5Ω~4Ω	1Ω~8Ω
t <sub>d</sub>	40ms~400 ms	100ms~350 ms
t <sub>r</sub>	(10 +0/-5 )ms	

	12V	24V
U <sub>s</sub>	79V~101V	151V~202V
U <sub>s</sub> *	35V	65V
t <sub>d</sub>	Same as 5A	

\* All the input voltage include U<sub>a</sub> value(14V/ 28V)

### Compare with ISO7637-2 & ISO16750-2

Parameter	ISO16750-2		Pulse(min)	ISO7637-2		Pulse (min)
	12V	24V		12V	24V	
U <sub>s</sub> (V)	79≤U <sub>s</sub> ≤101 <small>(65+14) ≤U<sub>s</sub>≤(87+14)</small>	151≤U <sub>s</sub> ≤202 <small>(123+28) ≤U<sub>s</sub>≤(174+28)</small>	10 times (Duration 1 minute)	65≤U <sub>s</sub> ≤87	123≤U <sub>s</sub> ≤174	1 time
U <sub>s</sub> *(V)	35(14+21)	65(28+37)		By Customer	By Customer	
U <sub>a</sub> (V)	14	28		13.5	27	
R <sub>i</sub> (Ω)	0.5≤R <sub>i</sub> ≤4	1≤R <sub>i</sub> ≤8		0.5≤R <sub>i</sub> ≤4	1≤R <sub>i</sub> ≤8	
T <sub>d</sub> (ms)	40≤T <sub>d</sub> ≤400	100≤T <sub>d</sub> ≤350		40≤T <sub>d</sub> ≤400	100≤T <sub>d</sub> ≤350	
Tr(ms)	10/-5	10/-5		10/-5	10/-5	



# CSPD Family

CERAMIC

## SHA Series (Automotive)

### Specification ( System for 12V )

All specification is base on datasheets and subject to change without notice.

	Part No.	Working Voltage	Breakdown Voltage	Clamping Voltage	Peak Current	Load Dump	Jump Start Voltage
		V <sup>DC</sup> (max.)	V <sup>B</sup> (1mA )	V <sup>C</sup> (max.)	I <sup>Peak</sup> (8/20μs)	W <sub>LD</sub>	V <sub>JUMP</sub>
0805	0805SA240-1R5J	16V	24V (±10%)	40V	200A (for +/- 1 time)	1.5J (for 10 times)	24.5V/5min
0806	0806SA240-060J	16V	24V (±10%)	40V	300A (for +/- 1 time)	6J (for 10 times)	24.5V/5min
	0806SA300-090J	16V	30V (±10%)	48V	300A (for +/- 1 time)	9J (for 10 times)	30.0V/5min
	0806SA330-090J	16V	33V (±10%)	53V	300A (for +/- 1 time)	9J (for 10 times)	32.5V/5min
1206	1206SA240-030J	16V	24V (±10%)	40V	400A (for +/- 1 time)	3J (for 10 times)	24.5V/5min
	1206SA240-060J	16V	24V (±10%)	40V	500A (for +/- 1 time)	6J (for 10 times)	24.5V/5min
	1206SA360-090J	16V	36V (±10%)	55V	500A (for +/- 1 time)	9J (for 10 times)	35.0V/5min
1210	1210SA240-060J	16V	24V (±10%)	40V	800A (for +/- 1 time)	6J (for 10 times)	24.5V/5min
	1210SA240-120J	16V	24V (±10%)	40V	1000A (for +/- 1 time)	12J(for 10 times)	24.5V/5min
	1210SA360-120J	16V	36V (±10%)	55V	800A (for +/- 1 time)	12J (for 10 times)	35.0V/5min
1812	1812SA240-120J	16V	24V (±10%)	40V	1600A (for +/- 1 time)	12J (for 10 times)	24.5V/5min
	1812SA240-250J	16V	24V (±10%)	40V	2000A (for +/- 1 time)	25J (for 10 times)	24.5V/5min
	1812SA360-250J	16V	36V (±10%)	55V	2000A (for +/- 1 time)	25J (for 10 times)	35.0V/5min
2220	2220SA240-500J	16V	24V (±10%)	40V	5000A (for +/- 1 time)	50J (for 10 times)	24.5V/5min
	2220SA330-500J	16V	33V (±10%)	53V	5000A (for +/- 1 time)	50J (for 10 times)	32.5V/5min
	2220SA360-500J	16V	36V (±10%)	55V	4000A (for +/- 1 time)	50J (for 10 times)	35.0V/5min
3220	3220SA240-800J	16V	24V (±10%)	40V	5500A (for +/- 1 time)	80J (for 10 times)	24.5V/5min
4032	4032SA240-161J	16V	24V (±10%)	40V	6000A (for +/- 1 time)	160J (for 10 times)	24.5V/5min

CSPD SHA

CSPD SHA

# CSPD Family

CERAMIC

## SHA Series (Automotive)

### Specification( System for 24V )

All specification is base on datasheets and subject to change without notice.

	Part No.	Working Voltage	Breakdown Voltage	Clamping Voltage	Peak Current	Load Dump	Jump Start Voltage
		V <sub>DC</sub> (max.)	V <sub>B</sub> (1mA )	V <sub>C</sub> (max.)	I <sub>Peak</sub> (8/20μs)	W <sub>LD</sub>	V <sub>JUMP</sub>
1206	1206SA470-030J	34V	47V (±10%)	77V	200A (for +/- 1 time)	3.0J (for 10 times)	45.0V/5min
1210	1210SA470-120J	34V	47V (±10%)	77V	500A (for +/- 1 time)	12J (for 10 times)	45.0V/5min
1812	1812SA470-250J	34V	47V (±10%)	77V	2000A (for +/- 1 time)	25J (for 10 times)	45.0V/5min
2220	2220SA470-250J	34V	47V (±10%)	77V	3000A (for +/- 1 time)	25J (for 10 times)	45.0V/5min
	2220SA470-500J	34V	47V (±10%)	77V	4000A (for +/- 1 time)	50J (for 10 times)	45.0V/5min
3220	3220SA470-500J	34V	47V (±10%)	77V	4000A (for +/- 1 time)	50J (for 10 times)	45.0V/5min
	3220SA470-800J	34V	47V (±10%)	77V	4500A (for +/- 1 time)	80J (for 10 times)	45.0V/5min
4032	4032SA470-161J	36V	45V ~ 53V	77V	6000A (for +/- 1 time)	160J (for 10 times)	48.0V/5min

### Specification( System for 12/24V )

All specification is base on datasheets and subject to change without notice.

	Part No.	Working Voltage	Breakdown Voltage	Clamping Voltage	Peak Current	Load Dump	Jump Start Voltage
		V <sub>DC</sub> (max.)	V <sub>B</sub> (1mA )	V <sub>C</sub> (max.)	I <sub>Peak</sub> (8/20μs)	W <sub>LD</sub>	V <sub>JUMP</sub>
0806	0806SA360-090V	24V	36V (±10%)	55V	300A (for +/- 1 time)	9J (for 10 times)	35.0V/5min
1206	1206SA360-090V	24V	36V (±10%)	55V	500A (for +/- 1 time)	9J (for 10 times)	35.0V/5min
1210	1210SA360-120V	24V	36V (±10%)	55V	800A (for +/- 1 time)	12J (for 10 times)	35.0V/5min
1812	1812SA360-250V	24V	36V (±10%)	55V	2000A (for +/- 1 time)	25J (for 10 times)	35.0V/5min
2220	2220SA360-500V	24V	36V (±10%)	55V	4000A (for +/- 1 time)	50J (for 10 times)	35.0V/5min
4032	4032SA360-161V	24V	36V (±10%)	55V	6000A (for +/- 1 time)	160J (for 10 times)	35.0V/5min

# CSPD Family

CERAMAIC

## SHN Series (Telecom/ Ethernet Non-PoE Application)

### Requirement

Now more popular in networking application in indoor and outdoor security all need for the overvoltage and lightning protected. The interface of RJ45, the circuit is 4 wires protection (1,2/3,6). In order to have full protection for 8 wires (1, 2; 3,6; 4,5; 7,8) and prevent the surge attacked, our CSPD products have the good characteristic and small size devices conjunction with the wires and will protect devices.

### Description

**SHN** Now more popular in networking application in indoor and outdoor security all need for the overvoltage and lightning protected. The interface of RJ45, the circuit is 4 wires protection (1,2/3,6).

In order to have full protection for 8 wires (1,2; 3,6; 4,5;7,8) and prevent the surge attacked, our CSPD products have the good characteristic and small size devices conjunction with the wires and will protect devices.

### Features

- Size : 1206~1812
- Meet IEC61000-4-5 10\*700 us 4~8KV
- Faster response time <0.5ns
- No extinguish problem
- Bi-direction

### Application

- Ethernet Device
- HUB/Switch/IAD
- RJ45 Socket

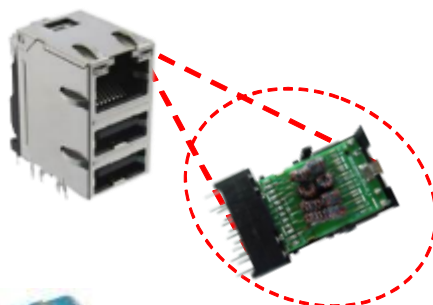

### Comparison with Other Solution

CSPD vs GDT

Function	CSPD	(GDT)	GDT
Size	1206, 1210	Φ5 x5.6	1206(3216) 1812(4532)
BDV	12 V	75V	200V 75V
Clamping Voltage	<25 V	>300V	>500V >300V
Surge (10/700μs)	6 KV	6 KV	4 KV 4 KV
Respond time	<1 ns	> 500ns	>100 ns >100 ns
Extinguishment	No	Yes	Yes Yes

### Reference Application Circuit Non-PoE

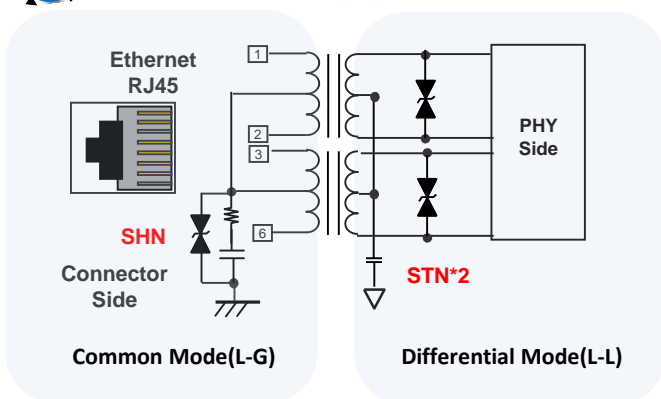

#### Ethernet (RJ45) surge protection

	Pass Level	Part No.
L-G	6KV	SFI1206SN120-060K
L-G	4KV	SFI1206SN120-040K
L-L	2KV	SFI0402TN050-1R5A-11
L-L	2KV	SFI0603TN050-1R5A-11

# CSPD Family

CERAMAIC

## SHN Series (Telecom/ Ethernet with PoE)

CSPD SHN

CSPD SHN

### Requirement

Power over Ethernet (PoE) is a technology which transfer power and data through Ethernet cables. They are including telecom systems, IP phone, wireless station, IP camera, hub, computers which get power by PoE. Therefore, it must be use surge protection for Ethernet RJ45 connectors. In telecom systems are connected by Ethernet and will also have the surge or voltage problem caused by power off by the surge. The surge protective device and pass the overvoltage to earth and clamp the voltage to avoid the system damage and broken. Now the standard of 100/1000M of Ethernet speed requirement and these precise devices protected is more important.

### Description

SFI has developed a dedicated in the Telecom PoE SHN series. SHN provides "small size SMD patch" packaging, which is the world's smallest chip package with fast response and high flow capacity, and avoids the problem of flameout caused by GDT. The current SHN protection components have been widely used by Netcom manufacturers.

### Features

- Size : 1210
- Meet IEC61000-4-5
- Faster response time <0.5ns than GDT
- No extinguish problem
- Bi-directional

### Application

- AP Router/Switch
- IAD
- IP CAM
- Others

### Comparison Traditional Solution

GDT Disadvantage : On application of PoE, due to the arc voltage is less than working after GDT discharge. Because the GDT will break and burn out and short, it becomes huge damage due to it's extinguish problem. In order to solve the issue, it's usually to put series of varistors or Sidactor after GDT to prevent extinguishment.

Our SHN strong characteristics :

1. Chip size
2. High flow ability
3. Low clamping volt
4. Quick response time and provide better solution than that.



### Reference Application Circuit for PoE

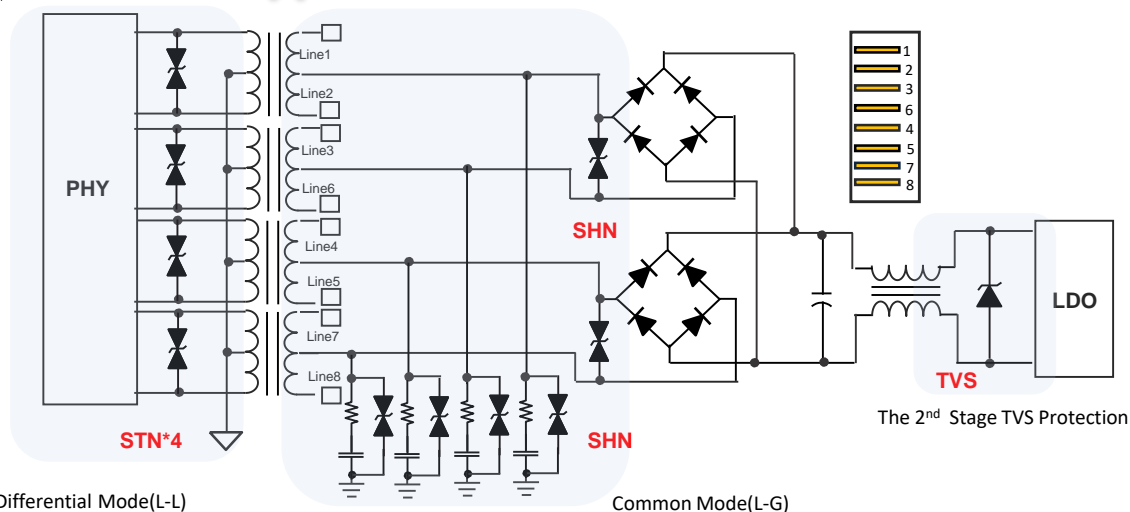

Differential Mode(L-L)		Pass Level	Part No.
L-L	2KV		SFI0402TN050-1R5A-11
L-L	2KV		SFI0603TN050-1R5A-11

Common Mode(L-G)		Pass Level	Part No.
L-G	6KV		SFI1210SN750-060K
L-G	4KV		SFI1210SN750-040K

# CSPD Family

CERAMIC

SHN Series (Telecom/ Ethernet)

## Specification

All specification is base on datasheets and subject to change without notice.

Size	Part No.	Working Voltage	Breakdown Voltage(*1)	Clamping Voltage(*2)	Surge Voltage	Surge Current(*3)	Typical Capacitance(*4)
		V <sub>DC</sub>	V <sub>B</sub> (1mA)	V <sub>C</sub> (max)	V <sub>Surge</sub> (10/700μs)	I <sub>Peak</sub> (10/700μs)	C(1KHz)
0806	0806SN120-040K	9V	12V (12~20)	30V	4KV	100A	2700pF
	0806SN120-060K	9V	12V (12~20)	30V	6KV	150A	3900pF
	0806SN750-010K	60V	75V (±10%)	100V	1KV	25A	180pF
1206	1206SN120-040K	9V	12V (12~20)	30V	4KV	100A	3200pF
	1206SN120-060K	9V	12V (12~20)	30V	6KV	150A	3850pF
1210	1210SN240-080K	18V	24V (±10%)	40V	8KV	200A	4600pF
	1210SN470-040K	38V	47V (±10%)	75V	4KV	100A	1400pF
	1210SN470-060K	38V	47V (±10%)	75V	6KV	150A	1670pF
	(*6)1210SN750-040K-UL	60V	75V (±10%)	100V	4KV	100A	1000pF
	(*6)1210SN750-060K-UL	60V	75V (±10%)	100V	6KV	150A	1300pF
	1210SN750-080K	60V	75V (±10%)	105V	8KV	200A	1350pF
	(*6)1210SN820-060S-UL	60V	67.5V (min)	100V	6KV	150A	1350pF
1812	1812SN750-080K	60V	75V (±10%)	105V	8KV	200A	3100pF

Notes :

- \* 1 The breakdown voltage was measured at 1 mA current.
- \* 2 The Clamping voltage was measured at 8/20 μs standard current, 0805~1206(1A),1210(2.5A),1812(5A)
- \* 3 The surge current was tested at 10/700μs waveform, Ri=40 Ω. Common-mode testing is to test all data lines while the GND.
- \* 4 The capacitance value only for customer reference, it's not formal specification.
- \* 5 The components shall be employed within 1 year, in the nitrogen condition.
- \* 6 SFI1210SN750-040K & SFI1210SN750-060K & SFI1210SN820-060S with UL Certification



# CSPD Family

CERAMAIC

## SHC Series (Bigger Current )

CSPD SHC

CSPD SHC

### Description

Most applications in communications base voltage of 48VDC voltage, lightning likely path through a coaxial cable or antenna to damage to the internal IC, will have a lot of power surges and voltage spikes on it. For a combination of lightning within base station power system, lightning protection circuit is relatively simple, but also more mature, usually in combination with through the DC side of the power flow to 15KA(8/20μs waveform) ways to DC SPD.



### Features

- Size : 0805~3220 (Inch)
- Meet : IEC61000-4-5  
1.2/50μs and 8/20μs combined wave
- Respond : < 0.5 ns
- BDV : 24V~82V
- Peak surge current : 200A~20KA
- Low leakage : <1μA
- Operating temperature : 125°C
- Bi-directional
- SMD package

### Comparison with Other Solution

	SHC	Others
Circuit	(A)	(B)
Size	2220	2220
Surge	10KA	4.5KA
Usage	1~2 pcs	3~5 pcs
Total cost	Low	High
Space rate	1/3	1

### Equal

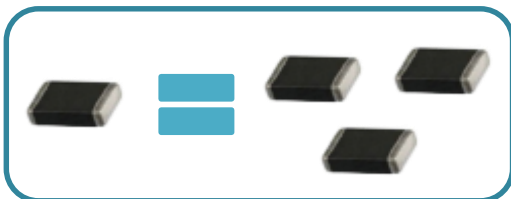

1 pcs (CSPD) = 3 pcs(Others)

### Reference Application Circuit

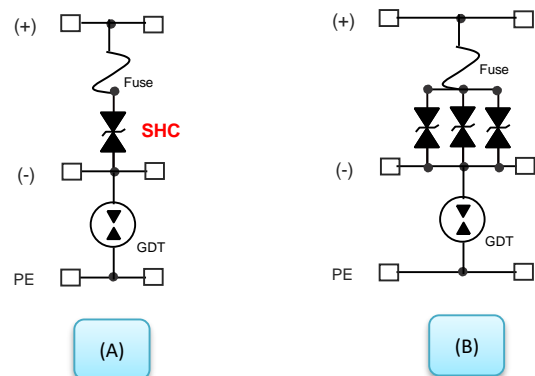

### Recommend Part No.

	Part Number	Working Voltage		Breakdown Voltage	Clamping Voltage	Surge Current (8/20 μs)
		AC	DC	V ( 1mA )	V	A
	Symbol					
	SFI2220SC750-103A	48	60	75(±10%)	< 100	10KA
★	SFI2220SC240-103A	14	18	24(±10%)	< 45	10KA
★	SFI3220SC240-203A	14	18	24(±10%)	< 45	20KA

# CSPD Family

## SHC Series (Bigger Current)

CERAMIC

### Specification

All specification is base on datasheets and subject to change without notice.

	Part No.	Working Voltage	Breakdown Voltage <sup>(*1)</sup>	Clamping Voltage <sup>(*2)</sup>	Surge Current <sup>(*3)</sup>	Typical Capacitance <sup>(*4)</sup>
		V <sub>DC</sub> (max.)	V <sub>BDV</sub> (1mA)	V <sub>C</sub> (max.)	I <sub>Peak</sub> (8/20μs)	Cap.(1KHz)
0805	0805SC180-181A	14V	18V (±10%)	30V	180A	520pF
	0805SC240-181A	18V	24V (±10%)	45V	180A	320pF
	0805SC470-181A	38V	47V (±10%)	85V	180A	150pF
1206	1206SC120-501A	9V	12V (12~20)	30V	500A	3500pF
	1206SC240-501A	18V	24V (±10%)	45V	500A	2300pF
	1206SC470-501A	38V	47V (±10%)	85V	500A	690pF
	1206SC560-102A	45V	56V (±10%)	90V	1000A	800pF
	1206SC750-501A	60V	75V (±10%)	100V	500A	300pF
1210	1210SC101-401A	85V	100V (±10%)	165V	400A	250pF
	1210SC101-102A	85V	100V (±10%)	165V	400A	250pF
	1210SC240-102A	18V	24V (±10%)	45V	1000A	2300pF
	1210SC470-102A	38V	47V (±10%)	85V	1000A	1550pF
	1210SC680-102A	56V	68V(61.7~75.3)	90V	1000A	950pF
	1210SC750-102A-UL	60V	75V (±10%)	100V	1000A	930pF
	1210SC750-122A-UL	60V	75V(+0%~+10%)	100V	1200A	930pF
	1210SC750-182A	60V	75V (±10%)	100V	1800A	980pF
	1210SC820-122A	65V	82V (±10%)	135V	1200A	800pF

Notes :

- \* 1 The breakdown voltage was measured at 1 mA current.
- \* 2 The Clamping voltage was measured at 8/20 μs standard current, 0806(1A), 1206(1A), 1210(2.5A), 1812(5A), 2220(10A), 3220(10A), 6420(10A).
- \* 3 The surge current was tested at 8/20 μs waveform.
- \* 4 The capacitance value only for customer reference, it's not formal specification.
- \* 5 The components shall be employed within 1 year, in nitrogen condition.

# CSPD Family

## SHC Series (Bigger Current)

CERAMIC

### Specification

All specification is base on datasheets and subject to change without notice.

	Part No.	Working Voltage	Breakdown Voltage <sup>(*1)</sup>	Clamping Voltage <sup>(*2)</sup>	Surge Current <sup>(*3)</sup>	Typical Capacitance <sup>(*4)</sup>
		V <sub>DC</sub> (max.)	V <sub>BDV</sub> (1mA)	V <sub>C</sub> (max.)	I <sub>Peak</sub> (8/20μs)	Cap.(1KHz)
1812	1812SC240-202A	18V	24V (±10%)	45V	2000A	4500pF
	1812SC470-202A	38V	47V (±10%)	85V	2000A	2100pF
	1812SC750-202A	60V	75V (±10%)	100V	2000A	1650pF
2220	2220SC240-103A	16V	24V (24~30)	45V	10000A	18000pF
	2220SC240-302A	18V	24V (±10%)	45V	3000A	5500pF
	2220SC470-302A	38V	47V (±10%)	85V	3000A	8000pF
	2220SC470-502A	38V	47V (±10%)	85V	5000A	9900pF
	2220SC470-802A	38V	47V (±10%)	85V	8000A	7500pF
	2220SC680-802A	56V	68V (±10%)	100V	8000A	5600pF
	2220SC750-302A	60V	75V (±10%)	100V	3000A	2000pF
	2220SC750-502A	60V	75V (±10%)	100V	5000A	2700pF
	2220SC820-452A	65V	82V (±10%)	135V	4500A	4800pF
	2220SC820-602A	65V	82V (±10%)	135V	6000A	3500pF
3220	3220SC240-123A	18V	24V (±10%)	45V	12000A	22000pF

Notes :

\* 1 The breakdown voltage was measured at 1 mA current.

\* 2 The Clamping voltage was measured at 8/20 μs standard current, 0806(1A),1206(1A),1210(2.5A),1812(5A), 2220(10A),3220(10A),6420(10A).

\* 3 The surge current was tested at 8/20 μs waveform.

\* 4 The capacitance value only for customer reference, it's not formal specification.

\* 5 The components shall be employed within 1 year, in nitrogen condition.

# CSPD Family

CERAMIC

## SEA Series (Automotive ESD)

### Requirement

CAN Bus is automotive signal interface. It is widely used in the automotive to transfer data between every electronic devices. It achieves a regional network control systems in whole vehicle and exchanges information between ECU electronic controls to become the automotive electronic control network. **SEA** series is designed for this request.

### Features

- Compliant with ISO10605 contact +/-30 KV
- Different capacitance values correspond to the different speed signal bus (CAN Bus)
- Compatible with (ISO7637-2)
  - Pulse 1 (max. -50 V)/ Pulse 2 (max. 125 V)
  - Pulses 3A and 3B
- Operating temperature exceeds : 125 °C
- Bi-directional
- Products with Lead-Free

### Application Area

- CAN BUS system
- Other special requirements

### Reference Application Circuit

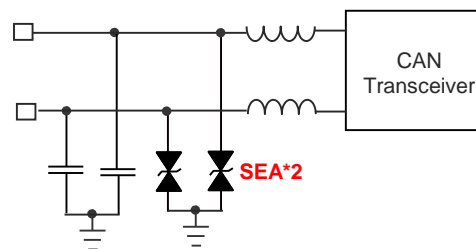

### SEA Specification

All specification is base on datasheets and subject to change without notice.

	Part No.	Stand-off Voltage	Breakdown Voltage	Clamping Voltage	Typical Capacitance	Leakage Current	ESD Ability
		V <sub>oc</sub> (max.)	V <sub>B</sub> (1mA)	V <sub>c</sub> (max.)	C(1MHz)	I <sub>LDC</sub>	V <sub>ESD</sub>
0402	0402EA240-HSP	16V	28V ~ 38V	57V	15pF (±30%)	<0.8μA	25KV
	0402EA470-HSP	28V	48V ~ 72V	108V	15pF (±30%)	<0.8μA	25KV
0603	0603EA240-LSP	16V	28V ~ 38V	57V	50pF (±30%)	<0.8μA	25KV
	0603EA240-MSP	16V	28V ~ 38V	57V	25pF (±30%)	<0.8μA	25KV
	0603EA240-HSP	16V	28V ~ 38V	57V	10pF (±30%)	<0.8μA	25KV
	0603EA470-LSP	28V	48V ~ 72V	108V	50pF (±30%)	<0.8μA	25KV
	0603EA470-HSP	28V	48V ~ 72V	108V	15pF (±30%)	<0.8μA	25KV
	0603EA510-LSP	32V	52V ~ 76V	110V	50pF (±30%)	<0.8μA	25KV
	0603EA680-HSP	42V	70V ~ 95V	140V	15pF (±30%)	<0.8μA	25KV
	0603EA750-HSP	60V	76V ~ 83V	110V	15pF (±30%)	<0.8μA	25KV
	0603EA111-HSP	75V	110V ~ 140V	200V	15pF (±30%)	<0.8μA	27KV
0805	0805EA470-XSP	36V	42.3V ~ 51.7V	77V	200pF (±30%)	<2.0μA	25KV

# CSPD Family

CERAMIC

## SEH Series (Ultra Low Capacitance)

### Feature

- Protection against high ESD voltages
- Compact size for EIA 0402 and 0603
- Quick response time (<0.5ns)
- Low capacitance (<0.05pF)
- Low leakage current
- Bi-directional
- RoHS compliance

### Application Area

- USB2.0 / USB3.0 /HDMI /DVI
- Motherboard
- Notebook
- Smart Phone
- STB
- DSC, DV, Scanner

### Characteristic

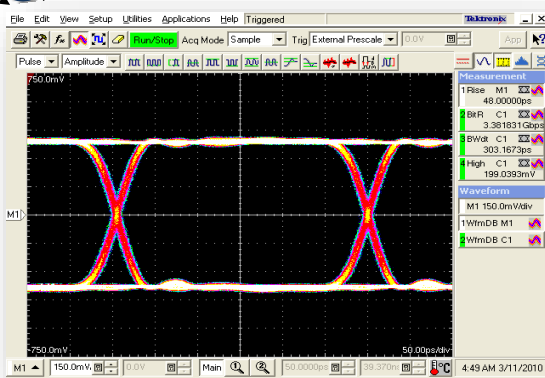

The Eye diagram of calibration for HDMI pattern (0.2pF at 3.4GHz)

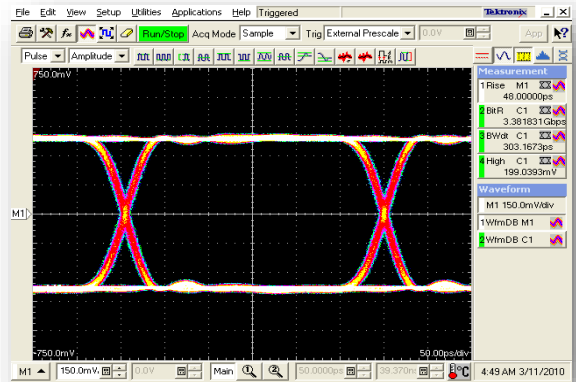

The Eye diagram of calibration for HDMI pattern (0.05pF at 3.4GHz)

### Specification

All specification is base on datasheets and subject to change without notice.

	Part No. (Unit)	Working Voltage	ESD Trigger Voltage	Clamping Voltage At 30ns.	Leakage Current	Capacitance Value	ESD (Contact)	ESD (Air)
		VDC (max.)	V <sub>T</sub> (typ.)	V <sub>c</sub> (typ.)	I <sub>LDC</sub>	C(1MHz)	V <sub>ESD</sub>	V <sub>ESD</sub>
0402	0402EH060-OR20P	6V	300V	30V	<0.05μA	0.20pF	8KV	15KV
	0402EH120-OR20P	12V	300V	30V	<0.05μA	0.20pF	8KV	15KV
	0402EH240-OR20P	24V	300V	30V	<0.05μA	0.20pF	8KV	15KV
0603	0603EH060-OR20P	6V	300V	30V	<0.05μA	0.20pF	8KV	15KV
	0603EH120-OR20P	12V	300V	30V	<0.05μA	0.20pF	8KV	15KV
	0603EH240-OR20P	24V	300V	30V	<0.05μA	0.20pF	8KV	15KV



# SGD Family

STS

STA

STN

STD

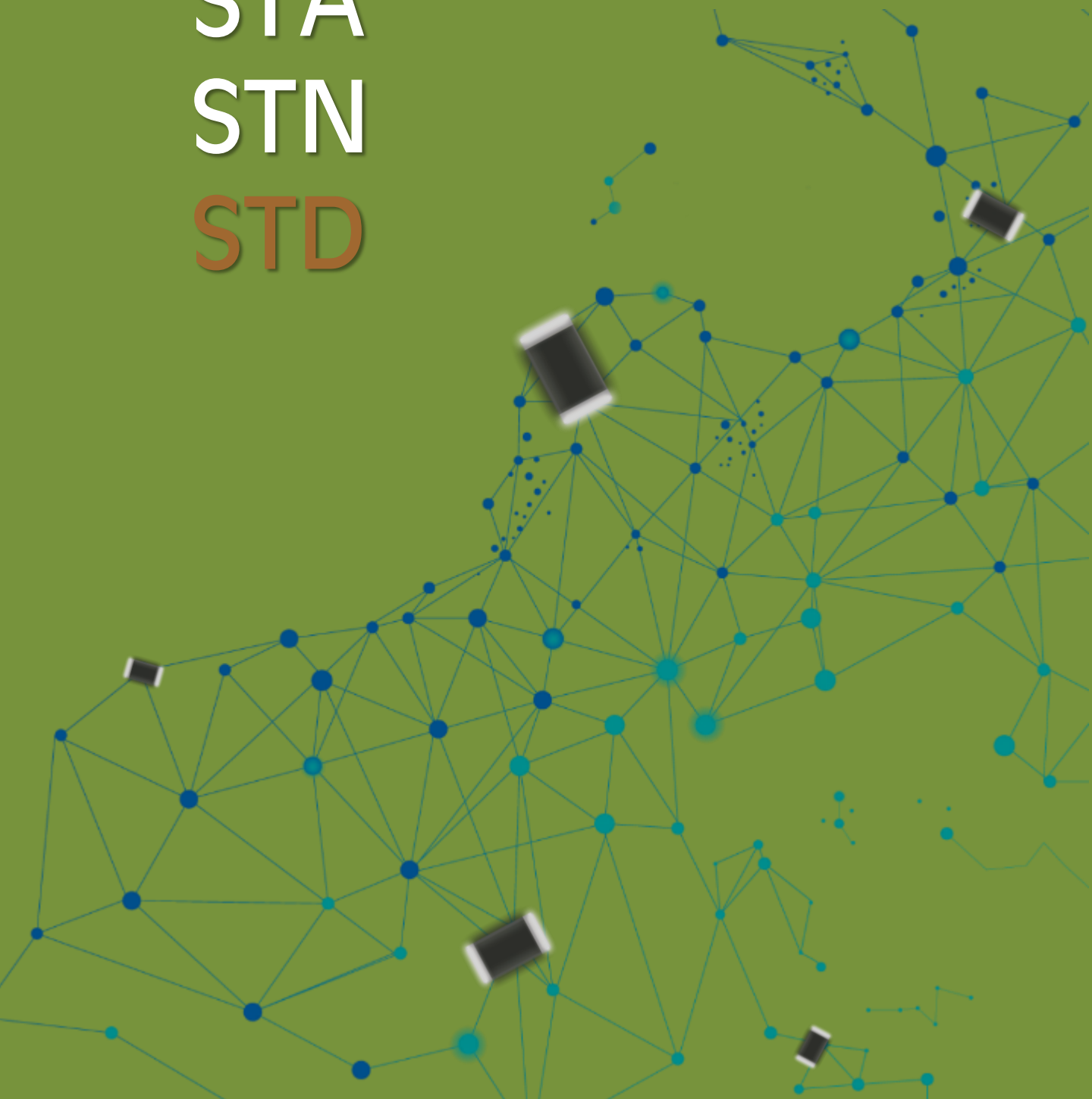

# SGD Family

## SGD Introduction

SEMI-CONDUCTOR

### Specification

#### New Technology

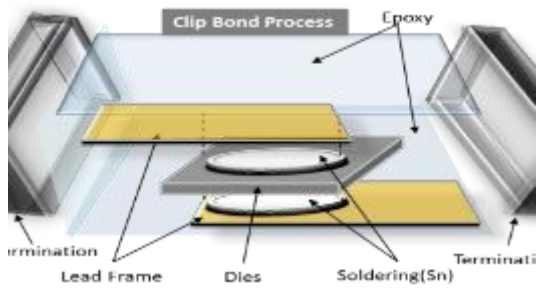

#### General Technology

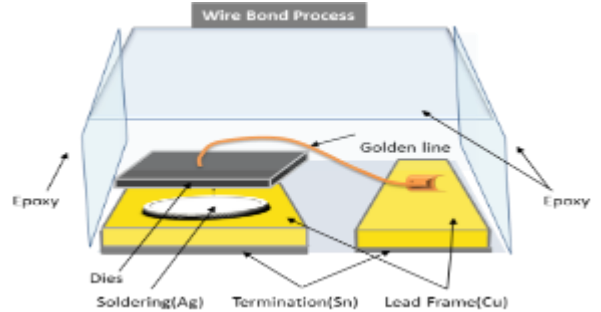

### Comparison inner Structure

#### Product exterior and structure

Item	Exterior Diagram	X-ray photo	
		Top View	Flank View
NEW TVS (SGD Clip)			
OLD TVS (DFN Wire)			

### SGD Package Advantage

	SGD (New TVS)	DFN (Old TVS)
Package	Clipped	Wire Bond
Contact Wafer	Surface	Point
ESD Robustness	25KV~30KV	15KV
Soldering ability	Good (5 Sides) 	Poor (Bottom Side) 
QC sampling	10,000pcs/ per set	77 pcs/ per set

# SGD Family

## STS Series (TVS Diode)

SEMI-CONDUCTOR

### STS Advantage

Background : With the progress of integrated circuits to the nanometer (nm) process, more and more speed, more functional design in one integrated circuit. Such miniaturization design, so as to increase the doping concentration also led thinner gate oxide layer, PN junction width reduction. Resulting IC can easily be damaged by static shock. At this time of protection elements, preferably inhibit low voltage, dynamic resistance is much lower than the protected IC, and has a very fast response time. SFI develops this product use Si wafer to develop TVS chip for smallest size 0201 vs 0402 TVS protect devices.

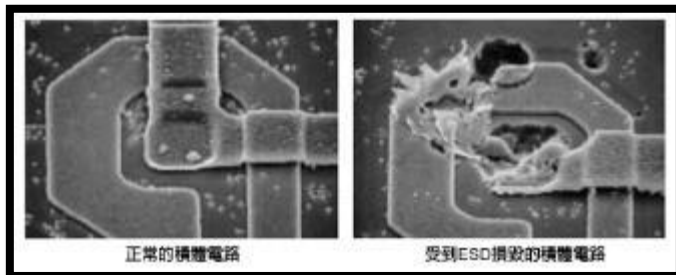
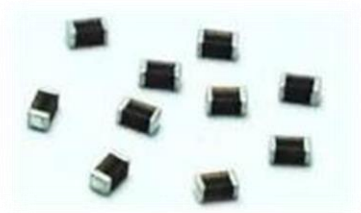

Normal Integrated Circuit

After ESD Strike Integrated Circuit

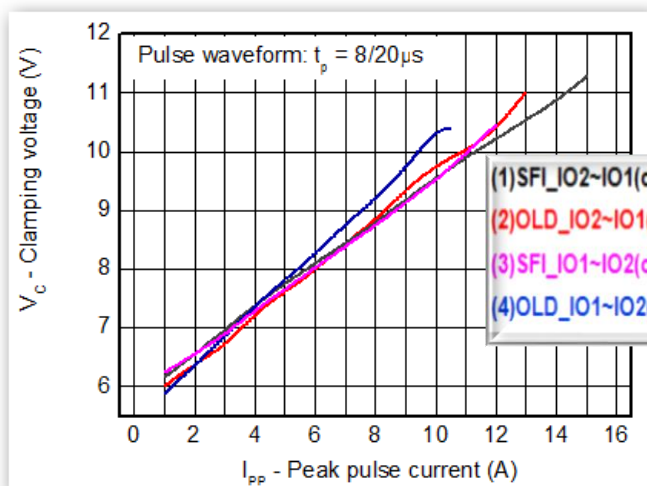

### Surge good

The surge ability of SFI product is better than DFN product about 2A. IO1~IO2...positive

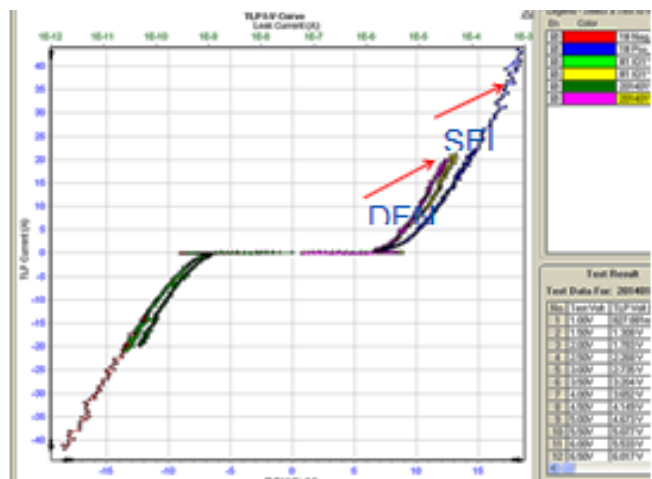

### TLP ability

The TLP ability of SFI product is better than DFN product. TLP(DFN) ability about 20A TLP(SFI) ability about 40A

SGD STS

SGD STS

# SGD Family

SEMI-CONDUCTOR

## SGD Footprint

### SGD series recommend footprint (mm)

SGD STS

SGD STS

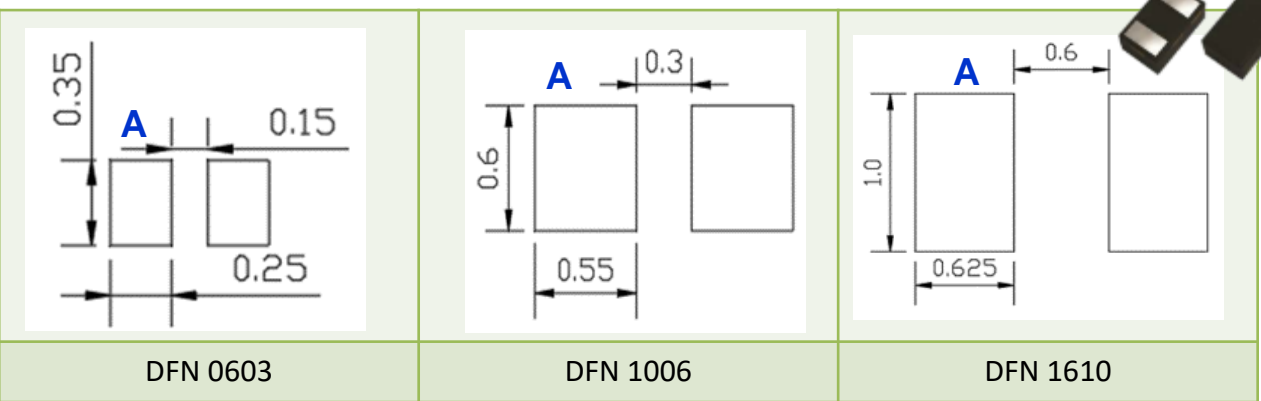
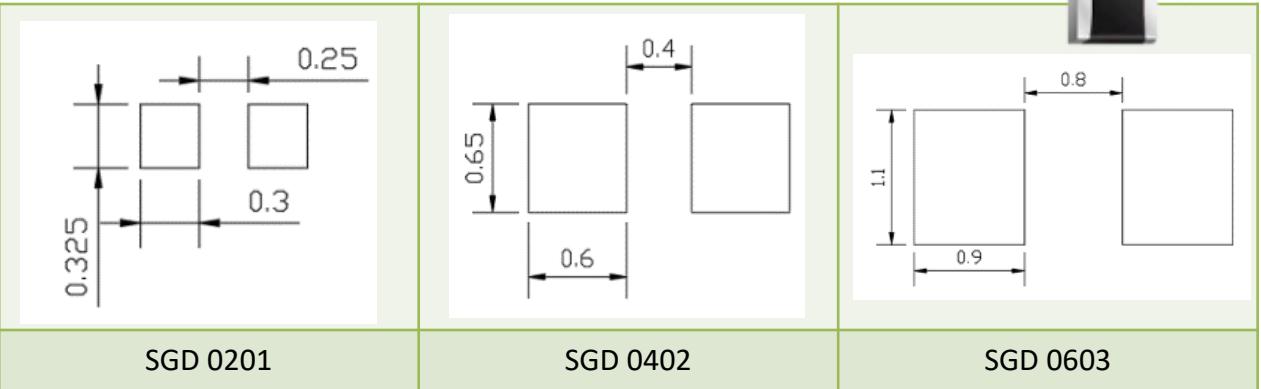

### Comparison DFN footprint

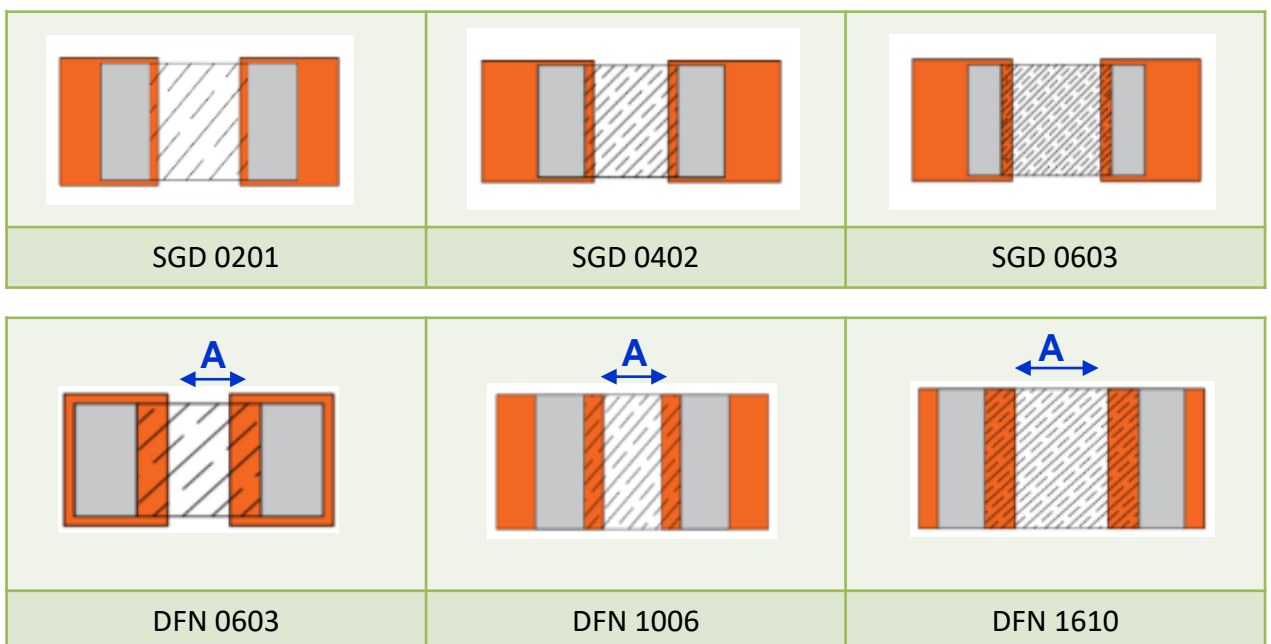

SGD and DFN can be pin to pin compatible in normal situation , but it due to DFN (A) distance is shorter than SGD (A), It is recommended that the thickness of SMT steel should be  $\leq 0.1\text{mm}$  to achieve the best SMT compatibility.

# SGD Family

## STS Series (TVS General Used)

SEMI-CONDUCTOR

### Specification

All specification is base on datasheets and subject to change without notice.

Series	Part No.	Reverse Working Voltage	Parasitic Capacitance	Leakage Current	ESD Ability		Clamping Voltage (ESD and TLP)		Peak Pulse Power	Peak Pulse Current
		VRWM (max.)	CESD (1MHz) (typ.)	IR (VRWM) (typ.)	VESD (air)	VESD (contact)	VCL (IPP 16A ,TLP) (max.)	VCL (VESD 8KV) (max.)	PPK (8/20μs)	IPP (8/20μs)
0201	0201TS3R3-100W-11	3.3V	10.0pF	0.001μA	±20KV	±20KV	12V	12V	70W	7A
	0201TS050-100W-11	5.0V	10.0pF	0.001μA	±20KV	±20KV	12V	12V	72W	6A
	0201TS050-0R3A-11	5.0V	0.3pF	0.001μA	±20KV	±20KV	30V	30V	60W	3A
	0201TS050-2R5A-11	5.0V	2.5pF	0.001μA	±20KV	±20KV	16V	16V	45W	3A
0402	0402TS3R3-0R5A-11(*)	3.3V	0.35pF	0.001μA	±15KV	±15KV	11V	11V	33W	3A
	0402TS3R3-100K-11	3.3V	10.0pF	0.001μA	±30KV	±30KV	10V	10V	80W	8A
	0402TS050-0R3W-11	5.0V	0.3pF	0.001μA	±20KV	±20KV	25V	25V	54W	3A
	0402TS050-0R5A-11	5.0V	0.35pF	0.001μA	±20KV	±20KV	15V	15V	60W	4A
	0402TS050-2R5A-11	5.0V	2.5pF	0.001μA	±15KV	±15KV	16V	16V	45W	3A
	0402TS050-050A-11	5.0V	5.0pF	0.001μA	±15KV	±15KV	15V	15V	64W	4A
	0402TS050-100A-11	5.0V	10.0pF	0.001μA	±30KV	±30KV	12V	12V	96W	8A
	0402TS050-170K-11	5.0V	17.0pF	0.001μA	±30KV	±30KV	12V	12V	80W	8A
	0402TS050-300A-11	5.0V	32.0pF	0.001μA	±30KV	±30KV	11V	11V	200W	18A
	0402TS6R5-0R3W-11	6.5V	0.3pF	0.003μA	±20KV	±20KV	30V	30V	54W	3A
	0402TS070-100A-11	7.0V	12.0pF	0.001μA	±30KV	±30KV	13V	13V	72W	6A
	0402TS120-060A-11	12.0V	6.0pF	0.001μA	±25KV	±25KV	22V	22V	130W	6A
0603	0603TS3R3-100K-11	3.3V	10.0pF	0.001μA	±30KV	±30KV	10V	10V	80W	8A
	0603TS050-0R3W-11	5.0V	0.3pF	0.001μA	±20KV	±20KV	30V	30V	54W	3A
	0603TS050-2R5A-11	5.0V	2.5pF	0.001μA	±15KV	±15KV	16V	16V	45W	3A
	0603TS050-100A-11	5.0V	10.0pF	0.001μA	±25KV	±25KV	12V	12V	96W	8A

Note :

\* With for deep snake back function

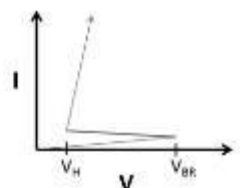
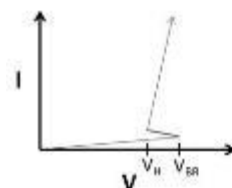

# SGD Family

SEMI-CONDUCTOR

## STA Series (TVS Diode for Automotive)

### Specification

All specification is base on datasheets and subject to change without notice.

Series	Part No.	Reverse Working Voltage	Parasitic Capacitance	Leakage Current	ESD Ability		Clamping Voltage (ESD and TLP)		Peak Pulse Power	Peak Pulse Current
		V <sub>RWM</sub> (max.)	C <sub>ESD</sub> (1MHz) (typ.)	I <sub>R</sub> (V <sub>RWM</sub> ) (typ.)	V <sub>ESD</sub> (air)	V <sub>ESD</sub> (contact)	V <sub>CL</sub> (I <sub>PP</sub> 16A, TLP) (max.)	V <sub>CL</sub> (V <sub>ESD</sub> 8KV) (max.)	PPK (8/20μs)	I <sub>PP</sub> (8/20μs)
0402	0402TA3R3-100K-11	3.3V	10.0pF	0.001μA	±25KV	±25KV	10V	10V	80W	8A
	0402TA050-0R3W-11	5.0V	0.3pF	0.001μA	±20KV	±20KV	30V	30V	54W	3A
	0402TA050-2R5A-11	5.0V	2.5pF	0.001μA	±12KV	±12KV	16V	16V	45W	3A
	0402TA050-100A-11	5.0V	10.0pF	0.001μA	±25KV	±25KV	12V	12V	96W	8A
	0402TA050-170K-11	5.0V	17.0pF	0.001μA	±25KV	±25KV	12V	12V	80W	8A
	0402TA070-100A-11	7.0V	12.0pF	0.001μA	±25KV	±25KV	12V	12V	72W	6A
	0402TA120-060A-11	12.0V	6.0pF	0.001μA	±25KV	±25KV	22V	22V	130W	6A
0603	0603TA3R3-100K-11	3.3V	10.0pF	0.001μA	±25KV	±25KV	10V	10V	80W	8A
	0603TA050-2R5A-11	5.0V	2.5pF	0.001μA	±12KV	±12KV	16V	16V	45W	3A
	0603TA050-100A-11	5.0V	10.0pF	0.001μA	±25KV	±25KV	12V	12V	96W	8A

### Reference Application Circuit

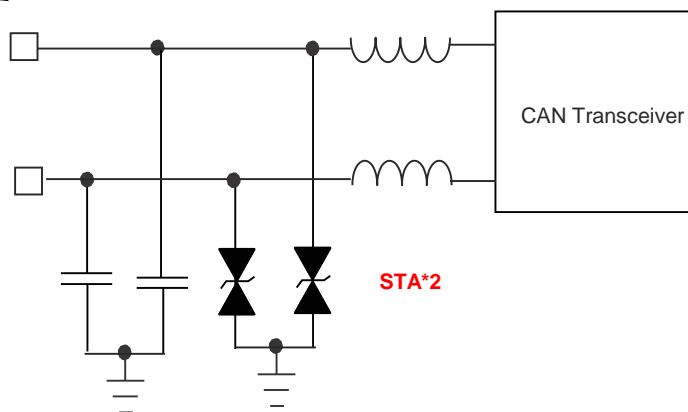

### Feature

- Ultra small package design
- Bi-Directional protection
- Low capacitance for high-speed data lines
- Meet Automotive ESD test ISO10605 ±25kV (Contact) and ±25kV(Air)
- Protects one data, control or power line
- Low leakage current: 0.1μA @ VRWM (max)
- Low clamping voltage

### Application

- In-Vehicle Networks
- Multimedia/Information buses
- CAN (Controller Area Network)
- LIN (Local Interconnected Network)
- In Data transceiver
- Ethernet , HDMI , LVDS
- USB Type C



# SGD Family

SEMI-CONDUCTOR

## STN Series (TVS Diode High Power)

### Specification

All specification is base on datasheets and subject to change without notice.

SGD STN	Series	Part No.	Reverse Working Voltage	Parasitic Capacitance	Leakage Current	ESD Ability		Clamping Voltage (ESD and TLP)		Peak Pulse Power	Peak Pulse Current	SGD STN
			$V_{RWM}$ (max.)	$C_{ESD}$ (1MHz) (typ.)	$I_R$ ( $V_{RWM}$ ) (typ.)	$V_{ESD}$ (air)	$V_{ESD}$ (contact)	$V_{CL}$ ( $I_{PP}$ 16A ,TLP) (max.)	$V_{CL}$ ( $V_{ESD}$ 8KV) (max.)	PPK (8/20 $\mu$ s)	$I_{PP}$ (8/20 $\mu$ s)	
	0402	0402TN050-0R8A-11	5.0V	0.8pF	0.001 $\mu$ A	$\pm$ 30KV	$\pm$ 30KV	13V	13V	100W	7A	
	0402	0402TN050-1R5A-11	5.0V	1.5pF	0.001 $\mu$ A	$\pm$ 30KV	$\pm$ 30KV	12V	12V	300W	15A	

### Feature

- Protect for high high-speed data lines
- High  $I_{pp}$  surge ability up to 15A
- IEC 61000-4-2 (ESD)  $\pm$ 30kV(Air),(Contact)
- Low capacitance design for high high-speed lines interface
- Ultra-small package (1.0mm\* 0.6mm\*0.5mm)
- Protects one data, control or power line
- Low capacitance: 1.5pF, 0.8pF (Typical)
- Low leakage current: 0.1 $\mu$ A @  $V_{RWM}$  (max)
- Low clamping voltage

### Application

- Ethernet PHY Side
- USB Power Charger( $V_{bus}$ )

### Reference Application Circuit

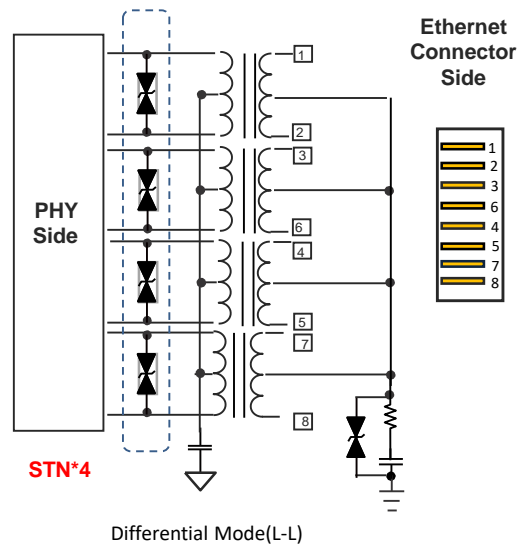
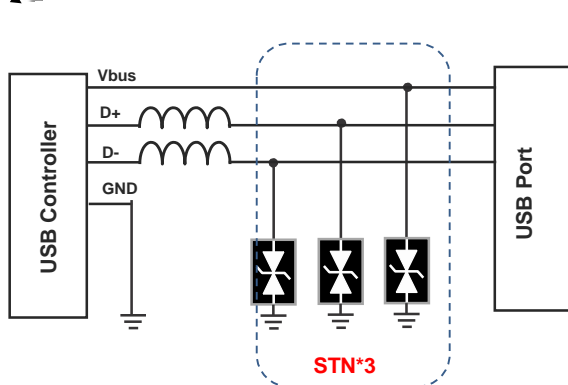

Differential Mode(L-L)

# SGD Family

Corona Discharge

STD(OR05) Series P Type (with ultra low capacitance)

SGD STD

SGD STD

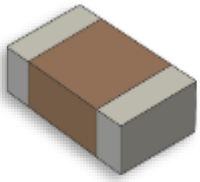

In a variety of port specifications, high-speed transmission speeds are as high as 10G or more. Therefore, the parasitic capacitance of the protection component must be relatively strict, and it must be below 0.1pF. The ultra-low capacitance electrostatic STD (OR05) developed by SFI is ultra-low Capacitor (0.05pF) components are used in ultra-high-speed transmission interfaces to protect circuits from problems caused by static electricity.

## Product Introduction :

The main structure of the ultra-low capacitance electrostatic suppressor is composed of two printed circuit boards (BT), an insulating frame (Epoxy film), and two T-shaped internal electrodes. The insulating frame is located between the two printed circuit boards to form a main structure with a cavity inside. In this manufacturing method, the thickness of the insulating frame can be adjusted to adjust the relative distance of different printed circuit boards, and then the trigger voltage of the electrostatic suppressor can be adjusted, Use the designed discharge path method to discharge electrostatic energy to suppress.

## Inner Structure :

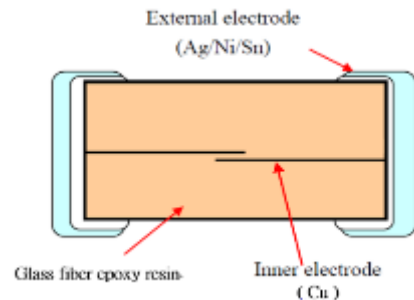
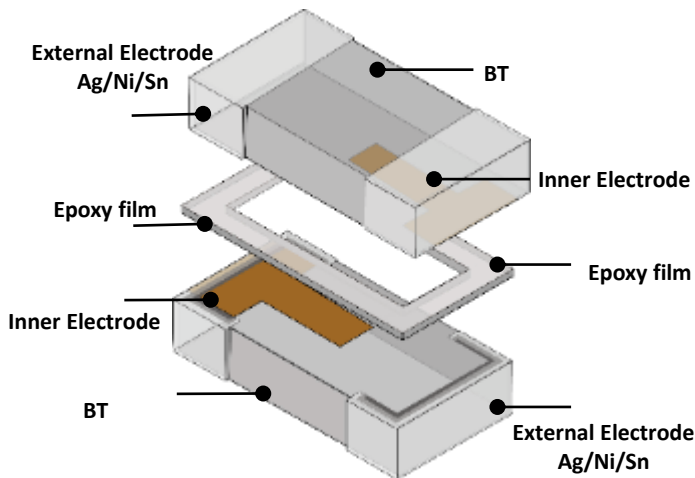

## X ray View :

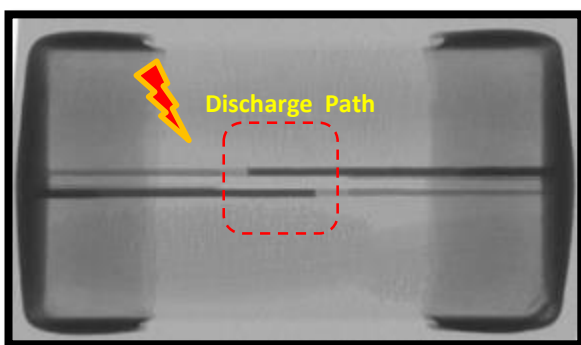

Side View

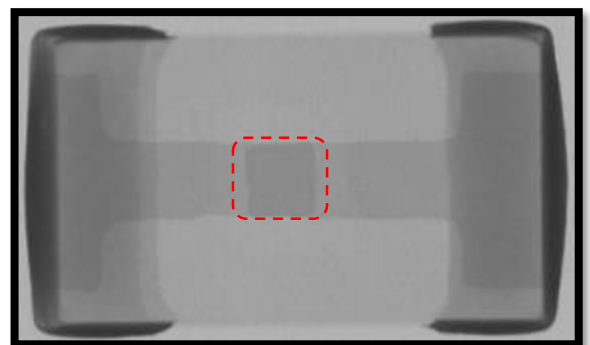

Top View

# SGD Family

Corona Discharge

STD(OR05) Series P TYPE (with ultra low capacitance)

## Specification

Series	Part No.	Working Voltage	Trigger Voltage	Clamping Voltage	Leakage Current		Cap. Value at 1MHz
		V <sub>DC</sub> (max.)	V <sub>trigger</sub> (typ.)	VC(typ.) at 30ns	ILDC (at Initial State)	ILDCA (after ESD Test)	C(max.)
0201	0201TD060-OR05P-11	6V	300V	30V	<0.05μA	<10μA	0.10pF
	0201TD120-OR05P-11	12V	300V	30V	<0.05μA	<10μA	0.10pF
	0201TD240-OR05P-11	24V	300V	30V	<0.05μA	<10μA	0.10pF
0402	0402TD060-OR05P-11	6V	300V	30V	<0.05μA	<10μA	0.10pF
	0402TD120-OR05P-11	12V	300V	30V	<0.05μA	<10μA	0.10pF
	0402TD240-OR05P-11	24V	300V	30V	<0.05μA	<10μA	0.10pF
0603	0603TD060-OR05P-11	6V	400V	30V	<0.05μA	<10μA	0.10pF
	0603TD120-OR05P-11	12V	400V	30V	<0.05μA	<10μA	0.10pF
	0603TD240-OR05P-11	24V	400V	30V	<0.05μA	<10μA	0.10pF

## Reference Application Circuit

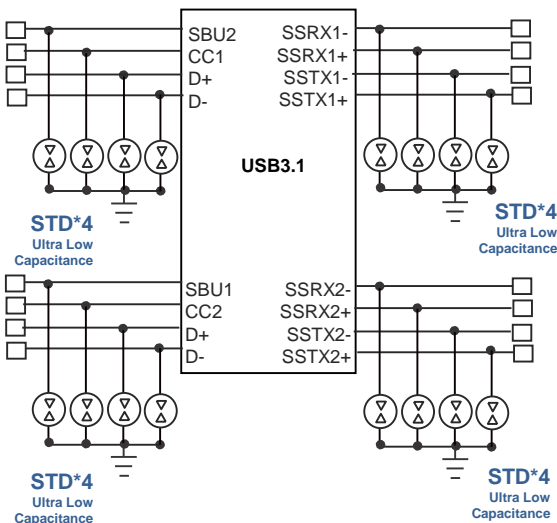

## Application

All ultra high speed data line

- USB 3.1
- HDMI 2.0
- Thunderbolt
- Wi-Fi 6
- Ethernet 10G
- Antenna

# SGD Family

Corona Discharge

STD(OR05) Series P TYPE (with ultra low capacitance)



Eyes Diagram



Insert Loss

Size 0201

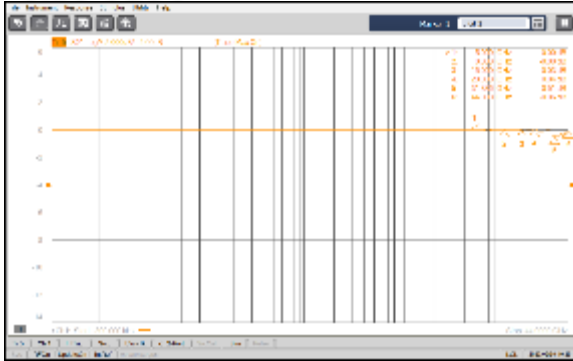

Eyes test range 20G

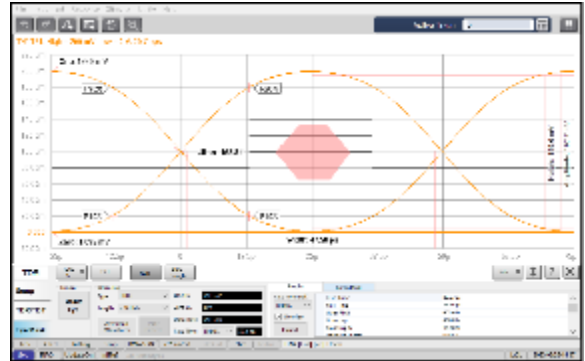

5G Hz	10G Hz	15G Hz	20G Hz	32G Hz	44G Hz
0	0	0.03	0.04	0.51	0.06

Size 0402

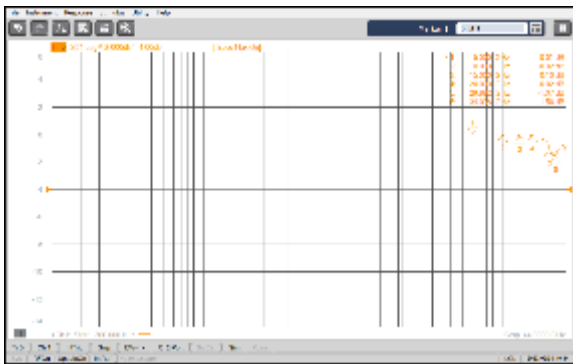

Eyes test range 20G

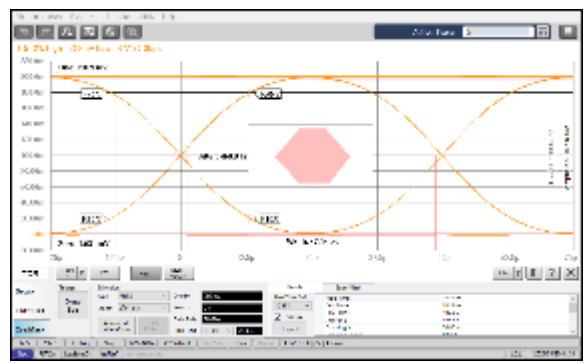

5G Hz	10G Hz	15G Hz	20G Hz	29.8G Hz	34.33G Hz
0.01	0.04	0.1	0.02	1.07	1.56

Size 0603

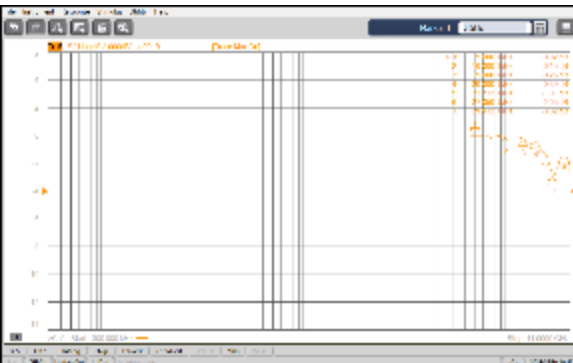

Eyes test range 20G

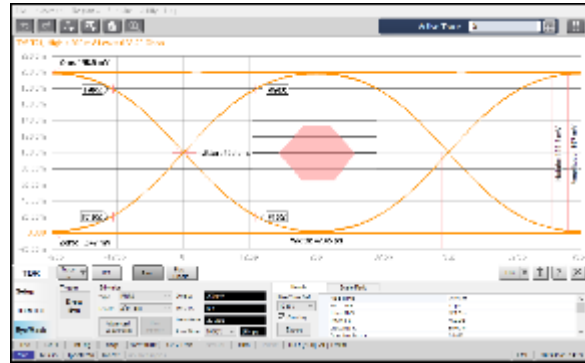

5G Hz	10G Hz	15G Hz	20G Hz	22.7G Hz	27G Hz	29.3GHz
0.02	0.15	0.26	0.39	1.01	2.06	3.02

SGD STD

SGD STD

# MLV Family

MLV-A

MLV-C

MLV-E

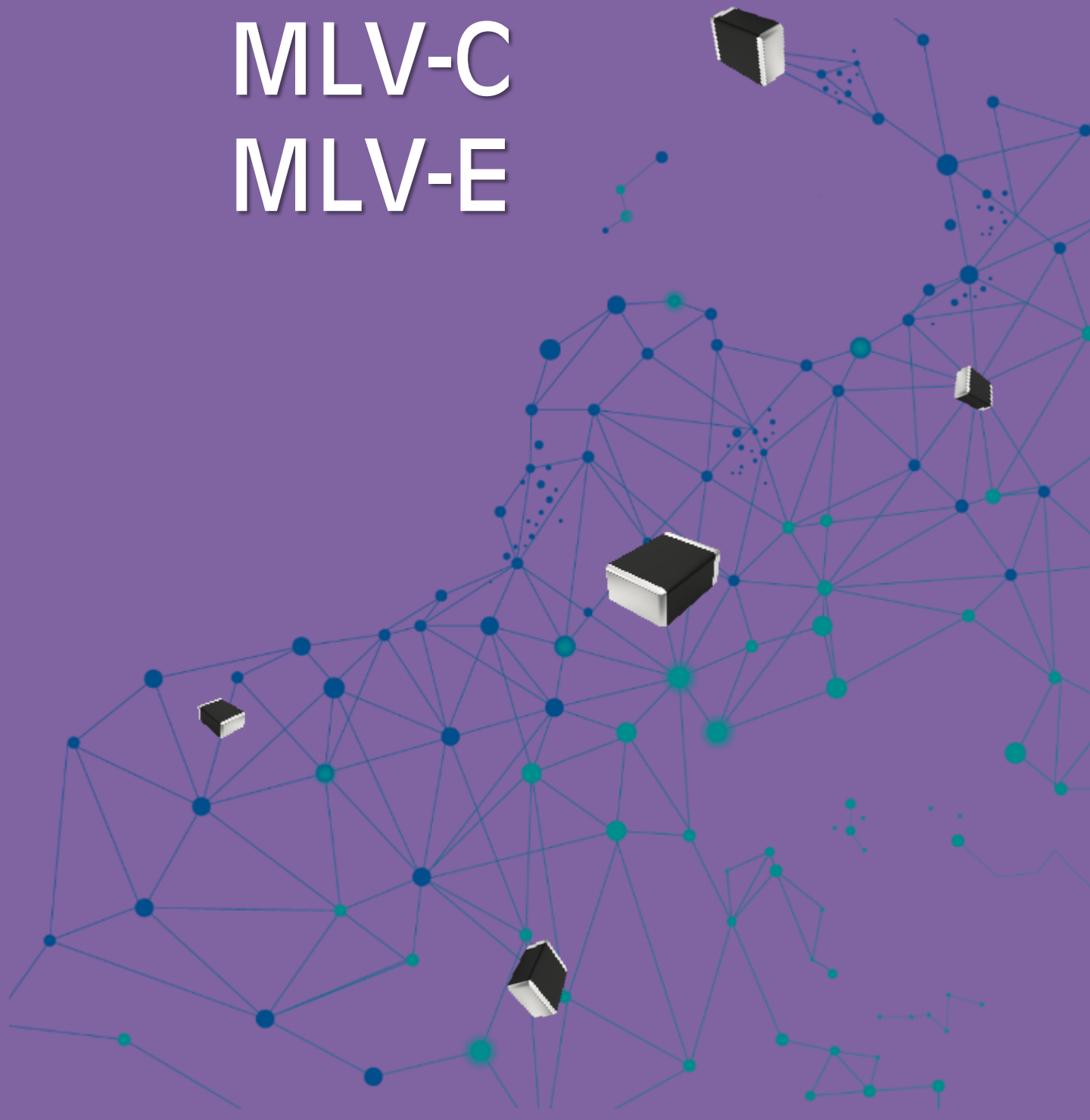

# MLV Family

CERAMIC

## A Series (General Used)

### Specification

All specification is base on datasheets and subject to change without notice.

	Part No.	Working Voltage		Breakdown Voltage	Clamping Voltage	Surge Current	Typical Capacitance
		VAC	VDC	V <sub>B</sub> (1mA)	V <sub>C</sub> (max.)	I <sub>Peak</sub> (8/20μs)	C(1KHz)
0805	0805ML240A-LF	14V	18V	24V (21.6 ~ 26.4)	39V	150A	710pF
1206	1206ML180A-LF	11V	14V	18V (15.3 ~ 20.7)	30V	200A	1200pF
	1206ML240A-LF	14V	18V	24V (21.6 ~ 26.4)	39V	200A	780pF
	1206ML270A-LF	17V	22V	27V (24.3 ~ 29.7)	44V	200A	750pF
	1206ML330A-LF	20V	26V	33V (29.7 ~ 36.3)	54V	200A	700pF
	1206ML390A-LF	25V	30V	39V (35.1 ~ 42.9)	65V	200A	510pF
	1206ML470A-LF	30V	38V	47V (42.3 ~ 51.7)	77V	200A	440pF
	1206ML560A-LF	35V	45V	56V (50.4 ~ 61.6)	90V	200A	400pF
1210	1210ML240A-LF	14V	18V	24V (21.6 ~ 26.4)	39V	400A	1600pF
	1210ML270A-LF	17V	22V	27V (24.3 ~ 29.7)	44V	400A	1500pF
	1210ML330A-LF	20V	26V	33V (29.7 ~ 36.3)	54V	400A	880pF
	1210ML390A-LF	25V	30V	39V (35.1 ~ 42.9)	65V	400A	800pF
	1210ML470A-LF	30V	38V	47V (42.3 ~ 51.7)	77V	400A	530pF
1812	1812ML240A-LF	14V	18V	24V (21.6 ~ 26.4)	39V	800A	3500pF
	1812ML390A-LF	25V	30V	39V (35.1 ~ 42.9)	65V	800A	2350pF
	1812ML470A-LF	30V	38V	47V (42.3 ~ 51.7)	77V	800A	1600pF
	1812ML560A-LF	35V	45V	56V (50.4 ~ 61.6)	90V	800A	1200pF
2220	2220ML180A-LF	11V	14V	18V (15.3 ~ 20.7)	30V	1200A	10500pF
	2220ML240A-LF	14V	18V	24V (21.6 ~ 26.4)	39V	1200A	8500pF
	2220ML270A-LF	17V	22V	27V (24.3 ~ 29.7)	44V	1200A	8300pF
	2220ML330A-LF	20V	26V	33V (29.7 ~ 36.3)	54V	1200A	8000pF
	2220ML390A-LF	25V	30V	39V (35.1 ~ 42.9)	65V	1200A	7500pF
	2220ML470A-LF	30V	38V	47V (42.3 ~ 51.7)	77V	1200A	4600pF
	2220ML560A-LF	35V	45V	56V (50.4 ~ 61.6)	90V	1200A	3500pF

MLV - A

MLV - A



# MLV Family

## C Series (General Used)

CERAMIC



### Specification

All specification is base on datasheets and subject to change without notice.

Part No.	Working Voltage		Breakdown Voltage	Clamping Voltage	Surge Current	Typical Capacitance	
	VAC	VDC	V <sub>B</sub> (1mA)	V <sub>C</sub> (max.)	I <sub>Peak</sub> (8/20μs)	C(1KHz)	
0402	0402ML080C-LF	4V	5.5V	8V (7.5 ~ 10.5)	20V	20A	200pF
	0402ML120C-LF	6V	9V	12V (10.2 ~ 13.8)	24V	20A	135pF
	0402ML180C-LF	11V	14V	18V (15.3 ~ 20.7)	35V	20A	50pF
	0402ML240C-LF	14V	18V	24V (21.6 ~ 26.4)	44V	20A	45pF
0603	0603ML080C-LF	4V	5.5V	8V (7.5 ~ 10.5)	20V	30A	650pF
	0603ML080CS-LF	4V	5.5V	8V (7.5 ~ 10.5)	20V	30A	300 ~ 385pF
	0603ML120C-LF	6V	9V	12V (10.2 ~ 13.8)	24V	30A	300pF
	0603ML180C-LF	11V	14V	18V (15.3 ~ 20.7)	30V	30A	210pF
	0603ML240C-LF	14V	18V	24V (21.6 ~ 26.4)	39V	30A	160pF
	0603ML270C-LF	17V	22V	27V (24.3 ~ 29.7)	44V	30A	145pF
	0603ML330C-LF	20V	26V	33V (29.7 ~ 36.3)	54V	30A	130pF
	0603ML390C-LF	25V	30V	39V (35.1 ~ 42.9)	65V	30A	110pF
	0603ML470C-LF	30V	38V	47V (42.3 ~ 51.7)	77V	30A	90pF
0805	0805ML080C-LF	4V	5.5V	8V (7.5 ~ 10.5)	20V	80A	1400pF
	0805ML120C-LF	6V	9V	12V (10.2 ~ 13.8)	24V	80A	650pF
	0805ML180C-LF	11V	14V	18V (15.3 ~ 20.7)	30V	100A	350pF
	0805ML240C-LF	14V	18V	24V (21.6 ~ 26.4)	39V	100A	300pF
	0805ML270C-LF	17V	22V	27V (24.3 ~ 29.7)	44V	100A	250pF
	0805ML330C-LF	20V	26V	33V (29.7 ~ 36.3)	54V	100A	220pF
	0805ML390C-LF	25V	30V	39V (35.1 ~ 42.9)	65V	100A	200pF
	0805ML470C-LF	30V	38V	47V (42.3 ~ 51.7)	77V	100A	150pF
	0805ML560C-LF	35V	45V	56V (50.4 ~ 61.6)	90V	80A	110pF

MLV - C

MLV - C

# MLV Family

## C Series (General Used)

CERAMIC



### Specification

All specification is base on datasheets and subject to change without notice.

	Part No.	Working Voltage		Breakdown Voltage	Clamping Voltage	Surge Current	Typical Capacitance
		VAC	VDC	V <sub>B</sub> (1mA)	V <sub>C</sub> (max.)	I <sub>Peak</sub> (8/20μs)	C(1kHz)
1206	1206ML080C-LF	4V	5.5V	8V (7.5 ~ 10.5)	20V	100A	3100pF
	1206ML180C-LF	11V	14V	18V (15.3 ~ 20.7)	30V	100A	800pF
	1206ML240C-LF	14V	18V	24V (21.6 ~ 26.4)	39V	100A	620pF
	1206ML270C-LF	17V	22V	27V (24.3 ~ 29.7)	44V	100A	700pF
	1206ML330C-LF	20V	26V	33V (29.7 ~ 36.3)	54V	100A	480pF
	1206ML390C-LF	25V	30V	39V (35.1 ~ 42.9)	65V	100A	400pF
	1206ML470C-LF	30V	38V	47V (42.3 ~ 51.7)	77V	100A	260pF
	1206ML560C-LF	35V	45V	56V (50.4 ~ 61.6)	90V	100A	230pF
	1206ML680C-LF	40V	56V	68V (61.2 ~ 74.8)	110V	100A	200pF
	1206ML820C-LF	50V	65V	82V (73.8 ~ 90.2)	135V	100A	175pF
1206ML101C-LF	60V	85V	100V (90.0 ~ 110)	165V	100A	150pF	
1210	1210ML080C-LF	4V	5.5V	8V (7.5 ~ 10.5)	20V	250A	5200pF
	1210ML240C-LF	14V	18V	24V (21.6 ~ 26.4)	39V	250A	1150pF
	1210ML330C-LF	20V	26V	33V (29.7 ~ 36.3)	54V	250A	610pF
	1210ML390C-LF	25V	30V	39V (35.1 ~ 42.9)	65V	250A	550pF
	1210ML560C-LF	35V	45V	56V (50.4 ~ 61.6)	90V	250A	400pF
	1210ML680C-LF	40V	56V	68V (61.2 ~ 74.8)	110V	250A	300pF
	1210ML101C-LF	60V	85V	100V (90.0 ~ 110)	165V	200A	210pF
1812	1812ML470C-LF	30V	38V	47V (42.3 ~ 51.7)	77V	500A	2200pF
	1812ML560C-LF	35V	45V	56V (50.4 ~ 61.6)	90V	500A	1000pF
	1812ML151C-LF	95V	127V	150V (135 ~ 165)	270V	600A	330pF
2220	2220ML270C-LF	17V	22V	27V (24.3 ~ 29.7)	44V	1000A	6600pF
	2220ML330C-LF	20V	26V	33V (29.7 ~ 36.3)	54V	1000A	6300pF
	2220ML390C-LF	25V	30V	39V (35.1 ~ 42.9)	65V	1000A	6000pF
	2220ML470C-LF	30V	38V	47V (42.3 ~ 51.7)	77V	1000A	4000pF
	2220ML680C-LF	40V	56V	68V (61.2 ~ 74.8)	110V	1000A	2000pF

MLV - C

MLV - C

# MLV Family

CERAMIC

## E Series (General Used/ Control Capacitance)



### Specification

All specification is base on datasheets and subject to change without notice.

Part No.	Working Voltage	Breakdown Voltage	Clamping Voltage	Capacitance Volume	ESD Contact	ESD Air	
	V <sub>DC</sub> (max)	V <sub>B</sub> (1mA)	V <sub>C</sub> (max.)	C(1MHz)	V <sub>ESD</sub>	V <sub>ESD</sub>	
0201	0201-050E050PP-LF	5V	28V ~ 38V	72V	5.0pF (+80~-20%)	8KV	15KV
	0201-050E100NP-LF	5V	28 V ~ 38V	72V	10pF (±30%)	8KV	15KV
	0201-050E330NP-LF	5V	18V ~ 28V	48V	33pF (±30%)	8KV	15KV
	0201-120E0R8PP-LF	12V	100V ~ 150V	200V	0.8pF (+80~-20%)	8KV	15KV
	0201-120E2R5PP-LF	12V	60V ~ 80V	130V	2.5pF (+80~-20%)	8KV	15KV
0402	0402-050E050PP-LF	5V	28V ~ 38V	72V	5.0pF (+80~-20%)	8KV	15KV
	0402-050E100NP-LF	5V	28V ~ 38V	72V	10pF (±30%)	8KV	15KV
	0402-050E220NP-LF	5V	18V ~ 28V	52V	22pF (±30%)	8KV	15KV
	0402-050E330NP-LF	5V	18V ~ 28V	52V	33pF (±30%)	8KV	15KV
	0402-050E560NP-LF	5V	18V ~ 28V	52V	56pF (±30%)	8KV	15KV
	0402-050E101NP-LF	5V	18V ~ 28V	52V	100pF (±30%)	8KV	15KV
	0402-120E050PP-LF	12V	28V ~ 38V	72V	5.0pF (+80~-20%)	8KV	15KV
	0402-120E100NP-LF	12V	28V ~ 38V	72V	10pF (±30%)	8KV	15KV
	0402-120E220NP-LF	12V	20V ~ 30V	55V	22pF (±30%)	8KV	15KV
	0402-120E330NP-LF	12V	20V ~ 30V	55V	33pF (±30%)	8KV	15KV
	0402-120E560NP-LF	12V	20V ~ 30V	55V	56pF (±30%)	8KV	15KV
	0402-120E101NP-LF	12V	20V ~ 30V	55V	100pF (±30%)	8KV	15KV
	0402-180E0R8PP-LF	18V	100V ~ 150V	200V	0.6~1.5pF (+80~-20%)	8KV	15KV
	0402-180E100NP-LF	18V	35V ~ 45V	85V	10pF (±30%)	8KV	15KV
	0402-240E0R8PP-LF	24V	100V ~ 150V	200V	0.8pF (+80~-20%)	8KV	15KV
	0402-240E1R8PP-LF	24V	100V ~ 150V	200V	1.8pF (+80~-20%)	8KV	15KV
	0402-240E2R5PP-LF	24V	100V ~ 150V	200V	2.5pF (+80~-20%)	8KV	15KV
	0402-240E3R0PP-LF	24V	48V ~ 72V	110V	3.0pF (+80~-20%)	8KV	15KV

#### Specification

1. This Clamping Voltage at which the device stabilized during the transition from high to low impedance 8/20μs waveform current 1A.
2. All capacitance tests are under 1MHz, and the Leakage current is measured at working voltage

# MLV Family

CERAMIC

## E Series (General Used/ Control Capacitance)



### Specification

All specification is base on datasheets and subject to change without notice.

	Part No.	Working Voltage	Breakdown Voltage	Clamping Voltage	Capacitance Volume	ESD Contact	ESD Air
		V <sub>DC</sub> (Max)	V <sub>B</sub> (1mA)	V <sub>C</sub> (max.)	C(1MHz)	V <sub>ESD</sub>	V <sub>ESD</sub>
0402	0402-420E0R8PP-LF	42V	100V ~ 150V	200V	0.8pF (+80~-20%)	8KV	15KV
	0402-420E2R5PP-LF	42V	100V ~ 150V	200V	2.5pF (+80~-20%)	8KV	15KV
0603	0603-050E050PP-LF	5V	20V ~ 30V	55V	5.0pF (+80~-20%)	8KV	15KV
	0603-050E100NP-LF	5V	24V ~ 36V	65V	10pF (±30%)	8KV	15KV
	0603-050E220NP-LF	5V	15V ~ 25V	34V	22pF (±30%)	8KV	15KV
	0603-050E330NP-LF	5V	15V ~ 25V	34V	33pF (±30%)	8KV	15KV
	0603-050E560NP-LF	5V	15V ~ 25V	36V	56pF (±30%)	8KV	15KV
	0603-050E101NP-LF	5V	15V ~ 25V	36V	100pF (±30%)	8KV	15KV
	0603-5R5T100NP-LF	5V	15V ~ 20V	36V	10pF (±30%)	8KV	15KV
	0603-120E050PP-LF	12V	33V ~ 50V	85V	5.0pF (+80~-20%)	8KV	15KV
	0603-120E100NP-LF	12V	27V ~ 42V	60V	10pF (±30%)	8KV	15KV
	0603-120E220NP-LF	12V	20V ~ 30V	55V	22pF (±30%)	8KV	15KV
	0603-120E330NP-LF	12V	20V ~ 30V	55V	33pF (±30%)	8KV	15KV
	0603-120E101NP-LF	12V	20V ~ 30V	55V	100pF (±30%)	8KV	15KV
	0603-240E0R8PP-LF	24V	100V ~ 150V	200V	0.8pF (+80~-20%)	8KV	15KV
	0603-240E2R5PP-LF	24V	100V ~ 150V	200V	2.5pF (+80~-20%)	8KV	15KV
	0603-240E3R0PP-LF	24V	48V ~ 72V	110V	3.0pF(+80~-20%)	8KV	15KV
	0603-850E2R5PP-LF	85V	140V ~ 180V	240V	2~4.5pF (+80~-20%)	8KV	15KV
0805	0805-050E560NP-LF	5V	20V ~ 28V	60V	56pF (±30%)	8KV	15KV
	0805-120E560NP-LF	12V	20V ~ 30V	60V	56pF (±30%)	8KV	15KV
	0805-120E101NP-LF	12V	20V ~ 28V	60V	100pF (±30%)	8KV	15KV

#### Specification

- 1.This Clamping Voltage at which the device stabilized during the transition from high to low impedance 8/20μs waveform current 1A.
2. All capacitance tests are under 1MHz, and the Leakage current is measured at working voltage

# Overview

## Series Size Table

Type	Product	SFI P/N.	(mm)Max			Page
			L	W	T	
CSPD	SHC	0805SC	2.00 ± 0.20	1.25 ± 0.15	1.30 Max	24~25
		1206SC	3.20+0.60/-0.20	1.60+0.40/-0.20	1.90 Max	
		1210SC	3.20+0.60/-0.20	2.50+0.40/-0.20	2.60 Max	
		1812SC	4.50+0.60/-0.20	3.20+0.50/-0.20	3.50 Max	
		2220SC	6.00+0.70/-0.30	5.30+0.50/-0.30	3.60 Max	
		3220SC	8.10+0.70/-0.30	5.30+0.60/-0.30	3.70 Max	
	SHN	0805SN	2.00 ± 0.20	1.25 ± 0.15	1.30 Max	22
		1206SN	3.20+0.60/-0.20	1.60+0.40/-0.20	1.90 Max	
		1210SN	3.20+0.60/-0.20	2.50+0.40/-0.20	2.60 Max	
		1812SN	4.50+0.60/-0.20	3.20+0.50/-0.20	3.50 Max	
		2220SN	6.00+0.70/-0.30	5.30+0.50/-0.30	3.60 Max	
	SHV	0806SV	2.20 ± 0.20	1.70 ± 0.20	1.80 Max	13~15
		1206SV	3.20+0.60/-0.20	1.60+0.40/-0.20	1.90 Max	
		1208SV	3.20+0.60/-0.20	2.20+0.40/-0.20	2.40 Max	
		1210SV	3.20+0.60/-0.20	2.50+0.40/-0.20	2.60 Max	
		1812SV	4.50+0.60/-0.20	3.20+0.50/-0.20	3.50 Max	
		2220SV	6.00+0.70/-0.30	5.30+0.50/-0.30	3.60 Max	
		3220SV	8.10+0.70/-0.30	5.30+0.60/-0.30	3.70 Max	
	SHR	0604SR	1.60 ± 0.15	1.05 ± 0.10	1.15Max	
	SHA	0805SA	2.00 ± 0.20	1.25 ± 0.15	1.30 Max	18~19
		1206SA	3.20+0.60/-0.20	1.60+0.40/-0.20	1.90 Max	
		1210SA	3.20+0.60/-0.20	2.50+0.40/-0.20	2.60 Max	
		1812SA	4.50+0.60/-0.20	3.20+0.50/-0.20	3.50 Max	
		2220SA	6.00+0.70/-0.30	5.30+0.50/-0.30	3.60 Max	
		3220SA	8.10+0.70/-0.30	5.03+0.60/-0.30	3.70 Max	
		4032SA	10.00+0.70/-0.30	8.00+0.60/-0.30	3.70 Max	
	SEA	0603EA	1.60 ± 0.15	0.80 ± 0.10	0.90 Max	26
		0805EA	2.00 ± 0.20	1.25 ± 0.15	1.20 Max	

OVERVIEW





OVERVIEW

# Overview

## Series Size Table

OVERVIEW

OVERVIEW

Type	Fig	Product	SFI P/N.	(mm)Max			Page
				L	W	T	
SGD Series		Normal ESD	0201TS	0.60 ± 0.03	0.30 ± 0.03	0.30 ± 0.03	32
			0402TS	1.00 ± 0.05	0.60 ± 0.05	0.50 ± 0.05	
			0603TS	1.60 ± 0.10	0.80 ± 0.10	0.60 ± 0.10	
		Auto ESD	0402TA	1.00 ± 0.05	0.60 ± 0.05	0.50 ± 0.05	33
			0603TA	1.60 ± 0.10	0.80 ± 0.10	0.60 ± 0.10	
		Networking	0402TN	1.00 ± 0.05	0.60 ± 0.05	0.50 ± 0.05	34
		High speed	0201TD	0.60 ± 0.03	0.30 ± 0.03	0.25 ± 0.03	35~37
			0402TD	1.00 ± 0.10	0.60 ± 0.10	0.50 ± 0.05	
			0603TD	1.60 ± 0.10	0.80 ± 0.10	0.60 ± 0.10	
		Multilayer Chip Varistor		High Surge	0805ML-A	2.00 ± 0.20	1.25 ± 0.15
1206ML-A	3.20 ± 0.20				1.60 ± 0.15	1.50 Max	
1210ML-A	3.20 ± 0.20				2.50 ± 0.20	1.50 Max	
1812ML-A	4.50 ± 0.20				3.20 ± 0.20	2.00 Max	
2220ML-A	5.70 ± 0.20				5.00 ± 0.20	2.50 Max	
Standard Surge	0402ML-C			1.00 ± 0.10	0.50 ± 0.10	0.60 Max	40~41
	0603ML-C			1.60 ± 0.15	0.80 ± 0.10	0.90 Max	
	0805ML-C			2.00 ± 0.20	1.25 ± 0.15	1.20 Max	
	1206ML-C			3.20 ± 0.20	1.60 ± 0.15	1.50 Max	
	1210ML-C			3.20 ± 0.20	2.50 ± 0.20	1.50 Max	
	1812ML-C		4.50 ± 0.20	3.20 ± 0.20	2.00 Max		
	2220ML-C		5.70 ± 0.20	5.00 ± 0.20	2.50 Max		
ESD	0201		0.60 ± 0.03	0.30 ± 0.03	0.30 ± 0.03	42~43	
	0402		1.00 ± 0.10	0.50 ± 0.10	0.60 Max		
	0603		1.60 ± 0.15	0.80 ± 0.10	0.90 Max		
	0805		2.00 ± 0.20	1.25 ± 0.15	1.20 Max		
High Voltage	08CH		8.10 ± 0.30	5.00 ± 0.30	2.50 Max	---	
	Low Cap.		0402	1.00 ± 0.10	0.50 ± 0.10	0.60 Max	---
			0603	1.60 ± 0.15	0.80 ± 0.10	0.90 Max	---
	Array		0508	2.00 ± 0.15	1.20 ± 0.15	0.80 Max	----
		0612	3.20 ± 0.20	1.60 ± 0.20	0.95 Max	----	





# *Message board*



**S**trength



**F**uture



**I**nternational

Taiwan Headquarter :

No.6, Lane 340, Shan Ying Road Guishan Township, Taoyuan County 333, Taiwan

TEL : +886-3-3506998  
FAX : +886-3-3507689  
E-mail : sfi@sfi.com.tw

Shenzhen China :

Room 2302, Zhantao Technology Building A, Minzhi Avenue, Longhua New District, Shenzhen China

Mobile phone : +86-15889610800  
TEL : +86-755-83589592-802  
QQ : 329880979  
E-mail : sz816@sfi.com.tw