

# XGZP6891D PRESSURE SENSOR

## FEATURES

---

- Wide Ranges:  $-100\text{kPa} \cdots -0.5 \sim 0 \sim 0.5 \cdots 100\text{kPa}$  (show in [Pressure Range Example](#))
- Optional 2.5V ~ 5.5V Power Supply
- Differential Pressure (Positive & Vacuum) Type
- For Dry Non-corrosive Gas or Air
- Calibrated Digital Signal (I2C Interface) (Refer to XGZP6891A for Analog signal)
- Temp. Compensated:  $0^{\circ}\text{C} \sim +60^{\circ}\text{C}$  ( $32^{\circ}\text{F} \sim +140^{\circ}\text{F}$ )
- Current Consumption:  $5\mu\text{A}$  (single measurement)
- Standby Current:  $<100\text{nA}$  ( $25^{\circ}\text{C}$ )

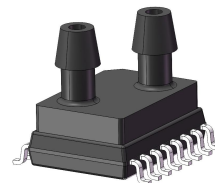

## APPLICATIONS

---

- Medical & Healthy: e.g. ventilators, CPAP, NPWT, DVT, blood analysis, blood pressure monitoring, drug dosing, hospital beds, oxygen concentrators, patient monitoring, sleep apnea equipment, urine analyzers and wound therapy, breast pumps, massage device etc.
- Consumer & Household: e.g. Robot, UAV, wearable device, coffee makers, washing machines, vacuum cleaners, hand dryers, air pump, air beds etc.
- Industrial & Automation: e.g. HVAC, flow and liquid level measurement, process control and monitoring, life sciences, pressure switch and meter, IoT and automotive application etc.

## INTRODUCTION

---

XGZP6891D is a perfect silicon pressure sensor offering a ratiometric digital data (I2C interface) for reading differential pressure over the specified full scale pressure span.

The XGZP6891D incorporates a silicon piezoresistive pressure sensor chip and an interior signal-conditional Application Specific Integrated Circuit (ASIC) in a SOIC-16 package with two air vents, which can be mounted directly on a standard PCB.

The XGZP6891D is fully calibrated and temperature compensated for specified span, so XGZP6891D pressure sensor satisfy the perfect accuracy, which is designed for a wide range of application in medical care & health, home appliances, consumer electronic, industry, automotive, IoT and other pneumatic devices etc by utilizing a microcontroller or microprocessor with D/A inputs.

XGZP6891D pressure sensor is for high volume application at an affordable cost and perfect performance. Customized calibration parameter (e.g. pressure range etc.) are available. If measured media is rather than the dry gas or air, e.g. moist media, contact CF Sensor for solution.

## PERFORMANCE PARAMETER

Unless otherwise specified, measurements were taken with a temperature of  $25\pm 1^{\circ}\text{C}$  and humidity of 50%RH.

Item	Data	Unit	Remark
Available Pressure Range <sup>1</sup>	<u>-10...-0.5 ~ 0 ~ 0.5...10</u>	kPa	Customization acceptable
Power Supply <sup>2</sup>	2.5~5.5	Vdc	
Max. Excitation Current	3	mA	
ADC Resolution <sup>3</sup>	24	Bit	
SDA/SCL pull up resistor	4.7	Kohm	
ESD HBM	4000	V	
Total Accuracy <sup>4</sup>	$\pm 2.5$	%Span	Customization acceptable
Long Term Stability <sup>5</sup>	$\pm 1$	%Span	
Over Pressure <sup>6</sup>	20	KPa	Base on P1 > P2
Burst Pressure <sup>7</sup>	60	KPa	
Max. Pressure on P2 Port	250	kPa	
Compensation Temp. <sup>8</sup>	0 ~ 60/32 ~ 140	$^{\circ}\text{C}/^{\circ}\text{F}$	Customization acceptable
Operating Temp. <sup>9</sup>	-20 ~ 100/-4 ~ 212	$^{\circ}\text{C}/^{\circ}\text{F}$	
Storage Temp.	-30 ~ 125/-22 ~ 257	$^{\circ}\text{C}/^{\circ}\text{F}$	
Response Time <sup>10</sup>	2.5	mS	

1 **Pressure Range(Operating pressure)**: The available pressure range including various span, not a specific pressure range.

2 **Power supply**: The default test voltage value: 3.3V, available working power supply voltage range:2.5 ~ 5.5V.

3 **ADC Resolution**: The ADC resolution is defined as the smallest incremental voltage that can be recognized and thus causes a change in the digital output.

4 **Total Accuracy**: The max. deviation in output from ideal transfer function at any pressure or temperature over the specified ranges, units are in percent of full scale span (%FSS), which mainly consists of: Offset and Span Shift;Linearity(Non-linearity); Repeatability; Pressure Hsteresis ; TcOffset and TcSpan.

4.1. The accuracy in table is the typical output accuracy. The accuracy is not identical accroding to different specified pressure range. Contact factory for more information or for higher accuracy requirement(e.g  $\pm 1\%$ Span) if need.

4.2 Non-linearity(Linearity): the deviation of measured output from "Best Straight Line" through three points (Offset pressure, FS pressure and  $\frac{1}{2}$  FS pressure)at constant temperature.

4.3 Repeatability: the deviation of measured output when the same pressure is applied continuously, with pressure approaching from the same direction within the specified operating pressure range,under the same operating conditions.

4.4 Pressure Hysteresis: the deviation of measured output at any pressure within the specified range, when this pressure is applied continuously, with pressure approaching from opposite directions within the specified operating pressure range, under the same operating conditions.

4.5 TcOffset (TCO:Temp. Coefficient of Offset): the deviation of measured output with minimum rated pressure applied, over the temperature range of  $0^{\circ}$  to  $60^{\circ}\text{C}$ , relative to  $25^{\circ}\text{C}$ .

4.6 TcSpan (TCS:Temp. Coefficient of Span): the deviation of measured output over the temperature range of  $0^{\circ}$  to  $60^{\circ}\text{C}$ , relative to  $25^{\circ}\text{C}$ .

5. **Long Term Stability**: the sensor's output deviation when subjected to 1000 hours pressure test.

6. **Over Pressure** (Proof pressure): the maximum pressure which may be applied without causing durable shifts of the electrical parameters of the sensing element and remain the specification once pressure is returned to the operating pressure range.
7. **Burst Pressure**: the maximum pressure which may be applied without causing damage to the sensing die or leaks; The sensor should not be expected to recover function after exposure to any pressure beyond the burst pressure.
8. **Compensated Temperature**: the temperature range over which the sensor have an output proportional to pressure within the specified performance limits.
9. **Operating Temperature** (or Ambient Temperature): the temperature range over which the sensor have an output proportional to pressure but may not remain within the specified performance limits.
10. **Response Time**: it is defined as the time for the incremental change in the output from 10% to 90% of its final value when subjected to a specified step change in pressure.

## ELECTRICAL CHARACTERISTICS(Interior ASIC)

Parameter	Min.	Typ.	Max.	Unit	Notes
Power Supply			5.5	V	
Working Current		100		nA	
Filter Capacitor		100		nF	
PSRR		60		dB	
Output Current Load			5	mA	
Input Common Mode Rejection Ratio	80	110		dB	
Short-circuit Current Limit	15	20	25	mA	
Upper limit Clamping Voltage	3/4		1	VDD	
Lower limit Clamping Voltage	0		1/4	VDD	

## BLOCK DIAGRAM

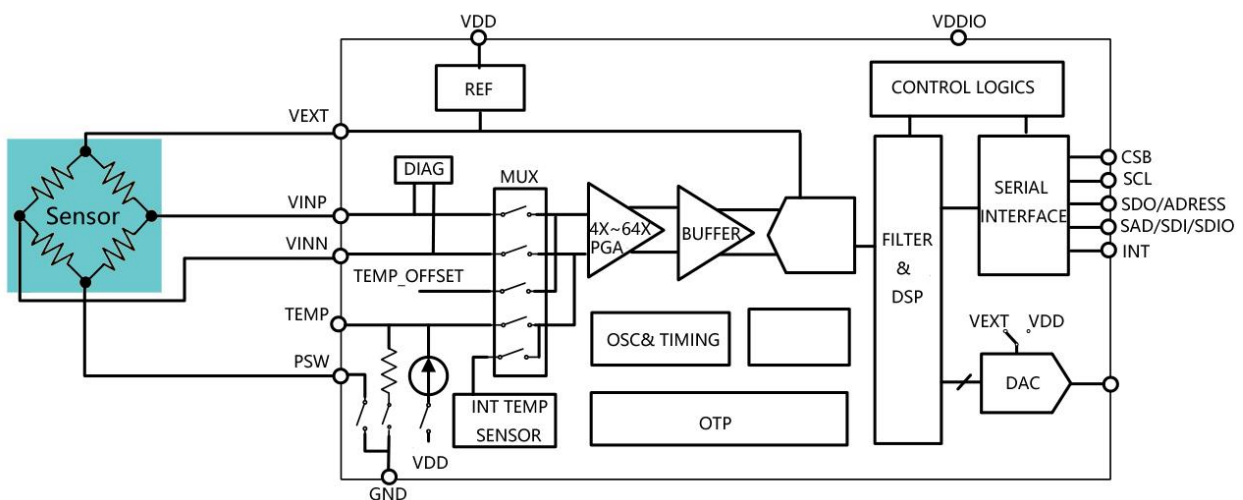

## DIMENSION (Unit:mm)

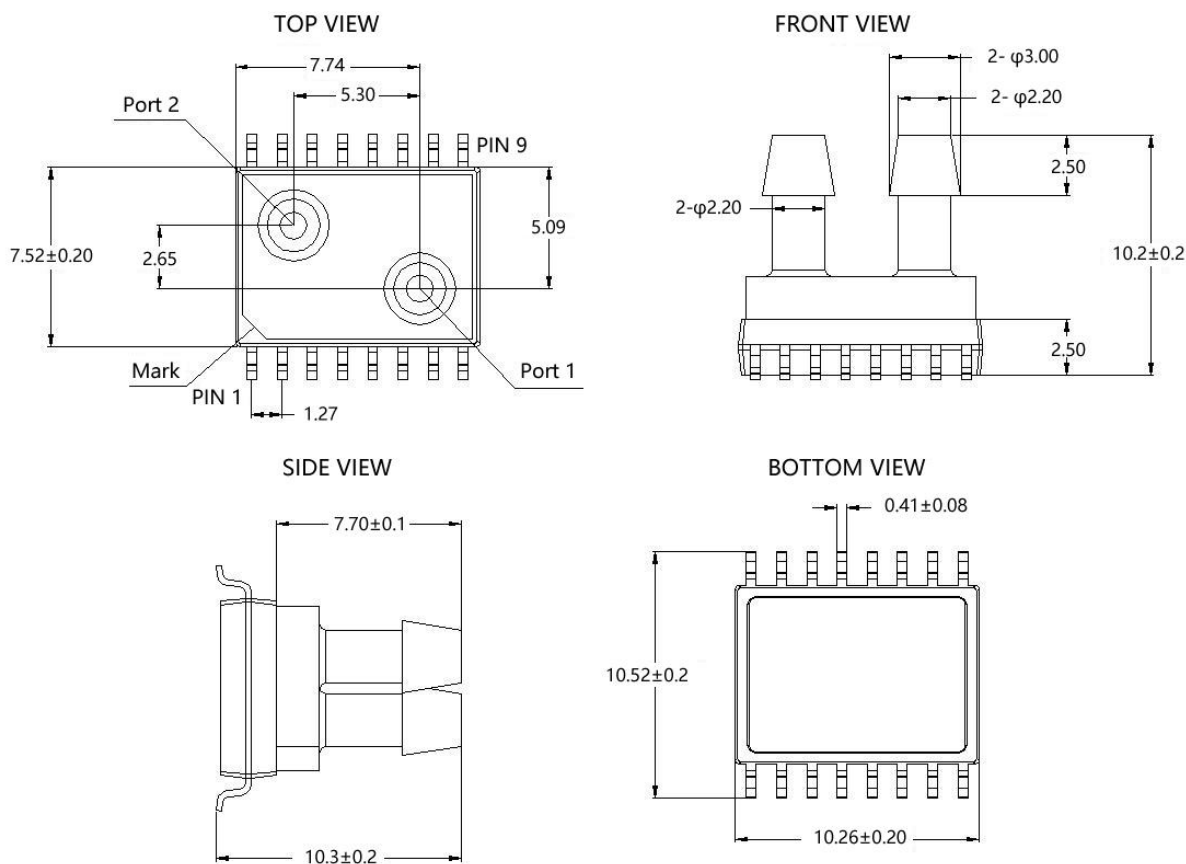

## ELECTRIC CONNECTION

6	7	10	11	Other PINs
GND	VDD	SDA	SCL	N/C

NAME	FUNCTION
N/C	Do not connect to external circuitry or ground
VDD	Voltage supply
GND	Ground
SCL	The clock signal
SDA	Data signal(Send& Receive)

## CIRCUIT DIAGRAM

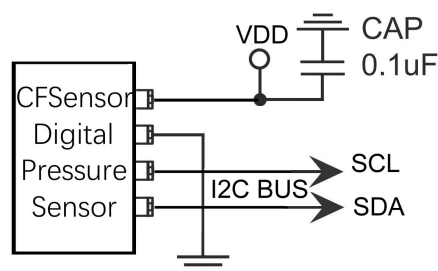

Note: Diagram state schematic connection only; Check Pin allocation in Dimension drawing.

### Notes:

- 1.,Port 1 as High pressure cavity, and Port 2 as Low pressure cavities.
2. Implement ESD protection during overall soldering and assembly process.
3. Overload voltage(max.6.5Vdc) or current(max.5mA) may burn the ASIC and cause the sensor fail throughly.
4. Donot make N/C PIN to any elctrical connenction, or may leads to function failure
- 5.More detalis about soldering and storage etc., refer to [Overall notes](#).

### CROSS SECTION

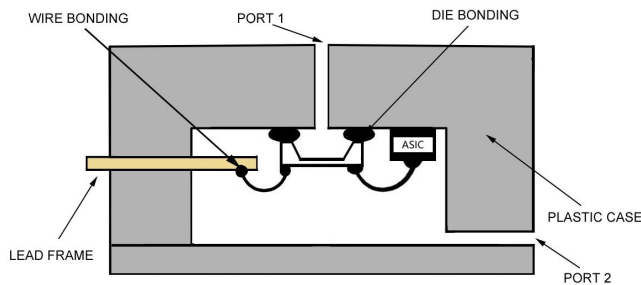

### FOOTPRINT(REFERENCE)

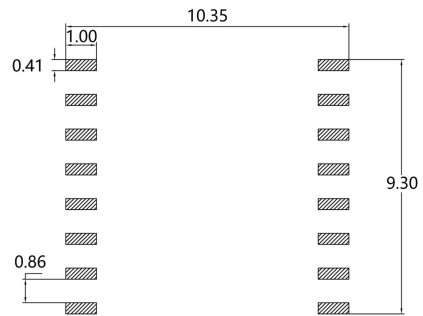

### ORDER GUIDE (100kPa=0.1MPa=1bar≈14.5PSI)

XGZP6891 D 001 KP DPN

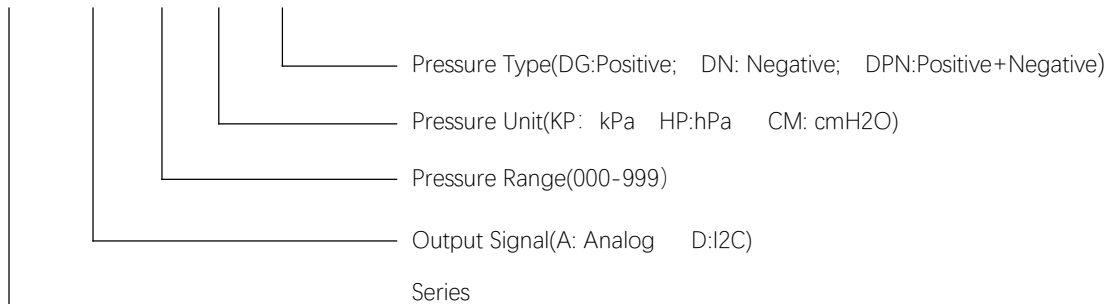

### PRESSURE RANGE EXAMPLE

- Notes: 1. Unit conversion: 1000hPa=1000mbar≈750mmHg≈100kPa≈14.5PSI≈10mH<sub>2</sub>O≈1bar=0.1MPa;  
 2. Available for more custom pressure range e.g. -5 ~ 100cm H<sub>2</sub>O; -20 ~ 140cm H<sub>2</sub>O etc.

Pressure Range	Pressure Range (Available units)	Part Number
-500 ~ 500Pa	-500 ~ 500Pa/-5mbar ~ 5mbar	XGZP6891D-005HPDPN
-1000 ~ 1000Pa	-1 ~ 1kPa/-10mbar ~ 10mbar	XGZP6891D-001KPDPN
-2500 ~ 2500Pa	-2.5 ~ 2.5kPa/-25mbar ~ 25mbar	XGZP6891D-025HPDPN
-5000 ~ 5000Pa	-5 ~ 5kPa/-50mbar ~ 50mbar	XGZP6891D-005KPDPN
-0.5 ~ 10cmH <sub>2</sub> O	-50 ~ 1000Pa/-0.5mbar ~ 10mbar	XGZP6891D-010CMDG
-10 ~ 10cmH <sub>2</sub> O	-1 ~ 1kPa/-10mbar ~ 10mbar	XGZP6891D-010CMDPN
-1 ~ 20cmH <sub>2</sub> O	-0.1 ~ 2kPa/-1mbar ~ 20mbar	XGZP6891D-020CMDG
-20 ~ 20cmH <sub>2</sub> O	-2 ~ 2kPa/-20mbar ~ 20mbar	XGZP6891D-020CMDPN
-5 ~ 40cmH <sub>2</sub> O	-0.5 ~ 4kPa/-5mbar ~ 40mbar	XGZP6891D-040CMDG
-40 ~ 40cmH <sub>2</sub> O	-4 ~ 4kPa/-40mbar ~ 40mbar	XGZP6891D-040CMDPN

◆ Please consult CFSensor whether required pressure range is under normal production before place order.

## I2C INTERFACE

I2C bus uses SCL and SDA as signal lines. Both lines are connected to VDD externally via pull-up resistors(Typ value:**4.7kΩ**) so that they are pulled high when the bus is free. I2C device factory setting slave address: **0x7F**.

The master device can communicate with the product using commands in the following format:

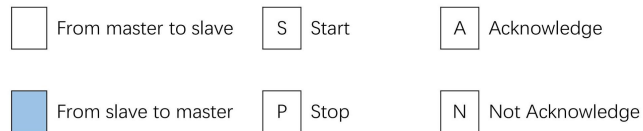

Write One Byte To One Register



Read One Byte From One Register

## ELECTRICAL SPEC. OF I2C INTERFACE PIN

Symbol	Parameter	Condition	Min	Max	Unit
$f_{scl}$	Clock frequency			400	KHz
$t_{LOW}$	SCL low pulse		1.3		US
$t_{HIGH}$	SCL high pulse		0.6		US
$t_{SUDAT}$	SDA setup time		0.1		US
$t_{HDDAT}$	SDA hold time		0.0		US
$t_{SUSTA}$	Setup Time for a repeated start		0.6		US
$t_{HDSTA}$	Hold time for a start condition		0.6		US
$t_{SUSTO}$	Setup Time for a stop condition		0.6		US
$t_{BUF}$	Time before a new transmission		1.3		US

## I2C TIME DIAGRAM

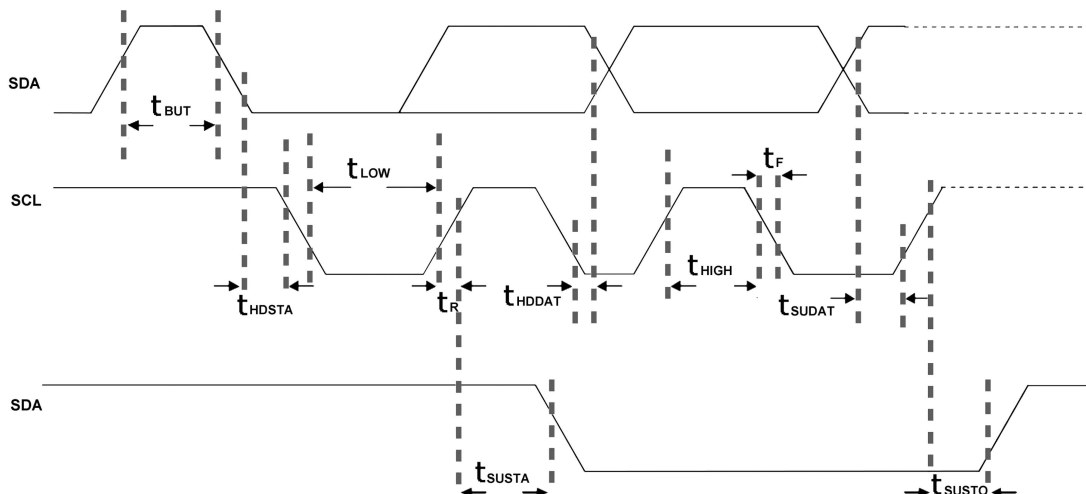

The I2C interface protocol has special bus signal conditions. Start (S), stop (P) and binary data conditions are shown below. At start condition, SCL is high and SDA has a falling edge. Then the slave address is sent. After the 7 address bits, the direction control bit R/W selects the read or write operation. When a slave device recognizes that it is being addressed, it should acknowledge by pulling SDA low in the ninth SCL (ACK) cycle.

At stop condition, SCL is also high, but SDA has a rising edge. Data must be held stable at SDA when SCL is high. Data can change value at SDA only when SCL is low.

## I2C PROTOCOL

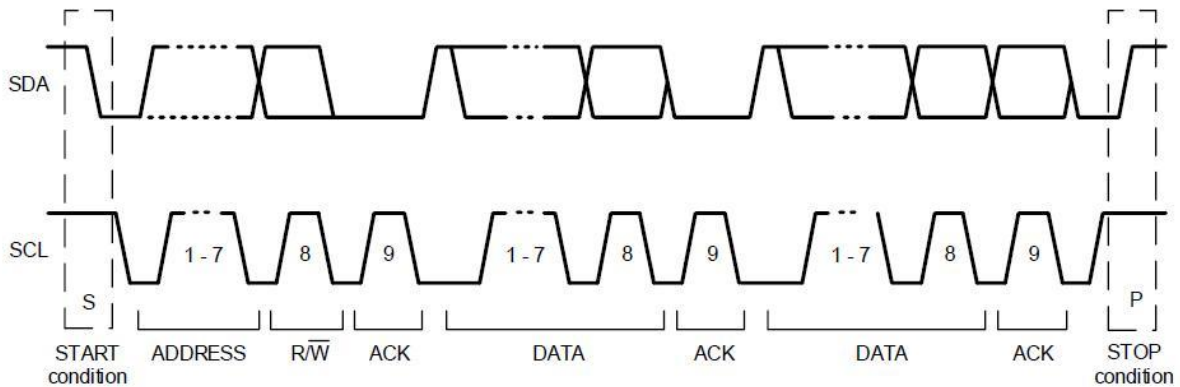

## REGISTER DESC.

Addr.	Desc.	R/W	Bit7	Bit6	Bit5	Bit4	Bit3	Bit2	Bit1	Bit0	Default
0x06	DATA_MSB	R	Pressure Data out<23:16>								0x00
0x07	DATA_CSB	R	Pressure Data out<15:8>								0x00
0x08	DATA_LSB	R	Pressure Data out<7:0>								0x00
0x09	TEMP_MSB	R	Temp Data out<15:8>								0x00
0x0A	TEMP_LSB	R	Temp Data out<7:0>								0x00
0x30	CMD	RW	Sleep_time<7:4>				Sc0	Measurement_ctrl<2:0>			0x00
0xA5	Sys_config	RW	Aout_config<7:4>				LDO_config	Unipolar	Data_out_control	Diag_on	OTP
0xA6	P_config	RW		Input Swap	Gain_P<5:3>			OSR_P<2:0>			OTP

### Reg0x06-Reg0x0A :

Pressure ADC data Register(Reg0x06-Reg0x08); Temperature ADC data Register(Reg0x09-Reg0x0A)

### Reg0x30 :

Measurement Command Register

Sleep\_time<7:4>: 0000:0ms; 0001:62.5ms; 0010:125ms ;... 1111: 1s, only active during sleep mode conversion.

Sc0: 1, Start of conversion, automatically come back to 0 after conversion ends (except sleep mode conversion).

Measurement\_control<2:0>:

010: indicate the combined conversion (namely a temperature conversion followed by a pressure-signal conversion).

011: indicate a sleep mode conversion (periodically perform a combined conversion with an interval time of 'sleep\_time'),

**Reg0xA5**(configured at factory)

Aout\_config<7:4>: Analog output setting(recommending reserve default value)

LDO\_config: 0: set with 1.8V; 1: setwith 3.6V.

Unipolar: 0: ADC output in bipolar format(signed binary), 1: ADC output in unipolar format. (Unsigned binary, Only take effect when 'raw\_data\_on' = 1)

Raw\_data\_on: 0: output calibrated data(as default value), 1: output ADC raw data.

Diag\_on: 1, Enable diagnosis function(default).

**Reg0xA6**(configured at factory)

Input Swap: Swap VINP and VINN inside the ASIC

Gain\_<5:3>: set the gain of the sensor signal conversion channel. 000: gain=1, 001: gain=2, 010: gain=4, 011: gain=8, 100: gain=16, 101: gain=32, 110: gain=64, 111: gain=128.

OSR\_P<2:0>: set the over sampling ratio of the sensor signal conversion channel. 000:1024X, 001:2048X, 010:4096X, 011:8192X, 100:256X, 101:512X, 110:16384X, 111:32768X.

## READ OPERATION

---

As the following instruction sequences for reading data:

(Only for combined conversion (namely a temperature conversion immediately followed by a pressure-signal conversion))

1. Send instructions 0x0A to 0x30 register for one temperature acquisition, one pressure data acquisition.
2. Read the 0x30 register address. If Sco bit is 0, signify the acquisition end, the data can be read.  
(Or, Hold 20mS and then skip this step to read data directly)
3. Read 0x06, 0x07, 0x08 register address data to form a 24-bit AD value (pressure data AD value); Read 0x09, 0x0A register address data to form a 16-bit AD value (temperature data AD value)

### Read Pressure

The total pressure output value which include 0x06, 0x07 and 0x08 registers are 24 bits. The highest position is the symbol bit, and the value is "1", it represents "negative pressure"; The symbol digit value is "0", it represents "positive pressure".

Pressure\_ADC value: = (Pressure 3rd Byte [23:16] x 65536+Pressure 2nd Byte [15:8] x 256 + Pressure1st Byte [7:0])

Note: 1 Pressure 3rd Byte [23:16] is the hexadecimal value read out by REG0x06 and need convert into decimal value;

2 Pressure 2nd Byte [15:8] is the hexadecimal value read out by REG0x07 and need convert into decimal value;

3 Pressure 1st Byte [7:0] is the hexadecimal value read out by REG0x08 and need convert into decimal value.

For Pressure conversion formula: Pressure=A\*Pressure\_ADC value+B:

(A and B is factor as below)



Pressure Range (Pa)		Output AD Span		Transfer-function Coefficient	
PL	PH	OL	OH	A	B
-500	500	838861	7549746	0.000149012	-625.0000559
-1000	1000	838861	7549746	0.000298023	-1250.000112
-2500	2500	838861	7549746	0.000745058	-3125.000279
-5000	5000	838861	7549746	0.001490116	-6250.000559
Pressure Range(CMH <sub>2</sub> O)		Output AD Span		Transfer-function Coefficient	
PL	PH	OL	OH	A	B
-0.5	10	838861	7549746	0.000001565	-1.812500587
-10	10	838861	7549746	0.000002980	-12.50000112
-1	20	838861	7549746	0.000003129	-3.625001173
-20	20	838861	7549746	0.000005960	-25.00000224
-5	40	838861	7549746	0.000006706	-10.62500251
-40	40	838861	7549746	0.000011921	-50.00000447

Note: the A and B factor is selected according to the required pressure range and the pressure unit

## Read Temperature

The bits of temperature output values in the 0x09 and 0x0A registers are 16 bits, the highest is the symbol bit.

The symbol digit value is "1" when it represents "negative", and the symbol digit value is "0" when it represents "positive".

Supposing if the decimal values of REG0x09 and REG0x0A readout are X, Y,

For Temperature ADC value and conversion formula are as:

Temperature AD value:  $N = X * 256 + Y$

If  $n < 2^{15}$ , Temperature is positive value, actual temperature  $T = N / 256$ ; (°C).

If  $n > 2^{15}$ , Temperature is negative value, actual temperature value =  $(N - 2^{16}) / 256$ ; (°C)

## OVERALL NOTES

Unless otherwise specified, following notes are general attention or presentation for all products from CFSensor.

### Mounting

The following steps is for transmitting the air pressure to sensor after sensor soldering on PCB.

- ▼ For some sensors that come with inlet tube, select the flexible pipe to suit the pressure inlet that is firm enough to prevent the pressure leaks.
- ▼ Atmosphere hole (for Gauge type sensors) and Inlet pipe/hole can't be blocked with gel or glue etc...
- ▼ Avoiding excessive external force operation

### Soldering

Due to its small size, the thermal capacity of the pressure sensor is low. Therefore, take steps to minimize the effects of external heat. Damage and changes to characteristics may occur due to heat deformation. Use a non-corrosive resin type of flux. Since the pressure sensor is exposed to the atmosphere, do not allow flux to enter inside.

- ▼ Manual soldering
  - Raise the temperature of the soldering tip to 190°C max. and solder within 5 seconds.
  - The sensor output may vary if the load is applied on the terminal during soldering.
  - Keep the soldering tip clean.
- ▼ Reflow soldering (SMD Terminal)

⊙ The recommended reflow temperature profile conditions are given below.

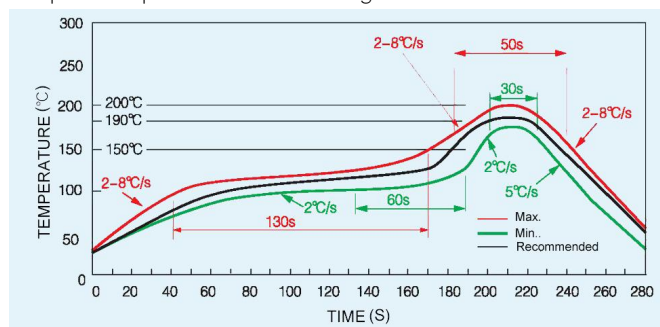

⊙ Self alignment may not always work as expected, therefore, please carefully the position of the terminals and pattern.

⊙ The temperature of the profile is assumed to be a value measured with the printed wiring board of the terminal neighborhood.

⊙ Please evaluate solderability under the actual mounting conditions since welding and deformation of the pressure inlet port may occur due to heat stress depending on equipments or conditions.

▼ Rework soldering

⊙ Complete rework at a time.

⊙ Use a flattened soldering tip when performing rework on the solder bridge. Do not add the flux.

⊙ Keep the soldering tip below the temperature described in the specifications.

▼ Avoid drop and rough handling as excessive force may deform the terminal and damage soldering characteristics.

▼ Keep the circuit board warpage within 0.05 mm of the full width of the sensor.

▼ After soldering, do not apply stress on the soldered part when cutting or bending the circuit board.

▼ Prevent human hands or metal pieces from contacting with the sensor terminal. Such contact may cause anomalous outlets as the terminal is exposed to the atmosphere.

▼ After soldering, prevent chemical agents from adhering to the sensor when applying coating to avoid insulation deterioration of the circuit board.

### Connecting

▼ Correctly wire as in the connection diagram. Reverse connection may damage the product and degrade the performance.

▼ Do not use idle terminals(N/C) to prevent damages to the sensor.

### Cleaning

▼ Since the pressure sensor is exposed to the atmosphere, do not allow cleaning fluid to enter inside from atmosphere hole (for Gauge type sensors) and inlet pipe.

▼ Avoid ultrasonic cleaning since this may cause breaks or disconnections in the wiring.

### Environment

▼ Please avoid using or storing the pressure sensor in a place exposed to corrosive gases (such as the gases given off by organic solvents, sulfurous acid gas, hydrogen sulfides, etc.) which will adversely affect the performance of the pressure sensor chip.

▼ Since this pressure sensor itself does not have a water-proof construction(even available media can be liquid), please do not use the sensor in a location where it may be sprayed with water, etc.

▼ Avoid using the pressure sensors in an environment where condensation may form. Furthermore, its output may fluctuate if any moisture adhering to it freezes.

▼ The pressure sensor is constructed in such a way that its output will fluctuate when it is exposed to light. Especially when pressure is to be applied by means of a transparent tube, take steps to prevent the pressure sensor chip from being exposed

to light.

- ▼ Avoid using pressure sensor where it will be susceptible to ultrasonic or other high-frequency vibration.
- ▼ Keeping the sensors sealed in static shielding bags with an oxygen-free condition and use the sensor as soon as possible once unfold the package, because the sensors' PINs may be oxidated a bit under atmosphere environment(slight oxidation wouldn't affect soldering and performance)

#### More Precautions

- ▼ That using the wrong pressure range or mounting method may result in accidents.
- ▼ The only direct pressure medium you can use is non-corrosive gas or air as illuminated above(Note: some sensors are compatible with liquid media). The use of other media, in particular, corrosive gases and liquid (organic solvent based, sulfurous acid based, and hydrogen sulfide based, etc.) or contains foreign substances will cause malfunction and damage. Please do not use them and check with CFSensor.
- ▼ The pressure sensor is positioned inside the pressure inlet. Never poke wires or other foreign matter through the pressure inlet since they may damage the sensor or block the inlet. Avoid use when the atmospheric pressure inlet(only for Gauge type pressure sensor) is blocked.
- ▼ Use an operating pressure which is within the rated pressure range. Using a pressure beyond this range may cause damage.
- ▼ Since static charge can damage the pressure sensor, bear in mind the following handling precautions.
  - When storing the pressure sensor, use a conductive material to short the pins or wrap the entire sensor in aluminum foil. Common plastic containers should not be used to store or transport the sensor since they readily become charged.
  - When using the pressure sensor, all the charged articles on the bench surface and the work personnel should be grounded so that any ambient static will be safely discharged.
- ▼ Based on the pressure involved, give due consideration to the securing of the pressure sensor.

### **【 SAFETY NOTES 】**

Using these sensors products may malfunction due to external interference and surges, therefore, please confirm the performance and quality in actual use. Just in case, please make a safety design on the device (fuse, circuit breaker, such as the installation of protection circuits, multiple devices, etc.), so it would not harm life, body, property, etc even a malfunction occurs. To prevent injuries and accidents, please be sure to observe the following items:

- The driving current and voltage should be used below the rated value.
- Please follow the terminal connection diagram for wiring. Especially for the reverse connection of the power supply, it will cause an accident due to circuit damage such as heat, smoke, fire, etc.
- In order to ensure safety, especially for important uses, please be sure to consider double safety circuit configuration.
- Do not apply pressure above the maximum applied pressure. In addition, please be careful not to mix foreign matter into the pressure medium. Otherwise, the sensor will be discarded, or the media will blew out and cause an accident.
- Be careful when fixing the product and connecting the pressure inlet. Otherwise, accidents may occur due to sensor scattering and the blowing out of the media.
- If the sensor come with sharp PIN, please be careful not to hurt your body when using it.

### **【 WARRANTY 】**

The information in this sheet has been carefully reviewed and is believed to be accurate; however, no responsibility is assumed for inaccuracies. Furthermore, this information does not convey to the purchaser of such devices any license under the patent rights to the manufacturer. CFSensor reserves the right to make changes without further notice to any product

herein. CFSensor makes no warranty, representation or guarantee regarding the suitability of its product for any particular purpose, nor does CFSensor assume any liability arising out of the application or use of any product or circuit and specifically disclaims any and all liability, including without limitation consequential or incidental damages. Typical parameters can and do vary in different applications. All operating parameters must be validated for each customer application by customer's technical experts. CFSensor does not convey any license under its patent rights nor the rights of others.

### 【 CONTACT 】

CFSensor

14-15F/4Bldg High-Tech Park High-Tech Area Wuhu P.R.C.241000

Tel/Fax: +86 18226771331      Email: INFO@CFSensor.com

North America || Europe || Southeast Asia || Middle East || Latin America

### **IIC Example Code** (C51 Language)

```
#include <reg52.h>
```

```
#include <math.h>

#define DELAY_TIME 600
#define TRUE 1
#define FALSE 0
#define uchar unsigned char
#define uint unsigned int
#define PARA_A 0.000149012 //参数 A 的值, 请根据传感器的量程进行对应的修改
    //The value of parameter A, please modify it based on the sensor's range
#define PARA_B -625.0000559 //参数 B 的值, 请根据传感器的量程进行对应的修改
    //The value of parameter B, please modify it based on the sensor's range

//----define IIC SCL, SDA port----
sbit SCL = P1 ^ 7; //定义 SCL 管脚
sbit SDA = P1 ^ 6; //定义 SDA 管脚

//----delay time_us----
void DELAY(uint t) //延时函数, 需要确保 IIC 总线时钟脉冲频率最大不超过 400KHz
{
    while (t != 0) //Ensure that the maximum clock pulse frequency of the IIC bus
        t--;      // does not exceed 400KHz
}

//----IIC bus clock pulse start function----
void I2C_Start(void) //IIC 总线时钟脉冲起始函数
{
    SDA = 1; //SDA output high
    DELAY(DELAY_TIME);
    SCL = 1;
    DELAY(DELAY_TIME); //SCL output high
    SDA = 0;
    DELAY(DELAY_TIME);
    SCL = 0;
    DELAY(DELAY_TIME);
}

//----IIC bus clock pulse stop function----
void I2C_Stop(void) //IIC 总线时钟脉冲停止函数
{
    SDA = 0; //SDA OUTPUT LOW
    DELAY(DELAY_TIME);
    SCL = 1;
```

```
    DELAY(DELAY_TIME);
    SDA = 1;
    DELAY(DELAY_TIME);
    SCL = 0; //SCL OUTPUT LOW
    DELAY(DELAY_TIME);
}

//----IIC SEND DATA "0"----
void SEND_0(void) //SDA 数据管脚发送"0"
{
    SDA = 0;
    DELAY(DELAY_TIME);
    SCL = 1;
    DELAY(DELAY_TIME);
    SCL = 0;
    DELAY(DELAY_TIME);
}

//----IIC SEND DATA "1"----
void SEND_1(void) //SDA 数据管脚发送"1"
{
    SDA = 1;
    DELAY(DELAY_TIME);
    SCL = 1;
    DELAY(DELAY_TIME);
    SCL = 0;
    DELAY(DELAY_TIME);
}

//----Check SLAVE's Acknowledge----
bit Check_Acknowledge(void) //检查从机是否发送了 ACK
{
    SDA = 1;
    DELAY(DELAY_TIME);
    SCL = 1;
    DELAY(DELAY_TIME / 2);
    F0 = SDA;
    DELAY(DELAY_TIME / 2);
    SCL = 0;
    DELAY(DELAY_TIME);
    if (F0 == 1)
        return FALSE;
```

```
    return TRUE;
}

//----Write One Byte of Data----
void Writel2CByte(uchar b) reentrant //发送一个字节数据
{
    char i;
    for (i = 0; i < 8; i++)
        if ((b << i) & 0x80)
            SEND_1();
        else
            SEND_0();
}

//----Read One Byte of Data----
uchar Readl2CByte(void) reentrant //读一个字节数据
{
    char b = 0, i;
    for (i = 0; i < 8; i++)
    {
        SDA = 1;
        DELAY(DELAY_TIME);
        SCL = 1;
        DELAY(DELAY_TIME);
        F0 = SDA;
        DELAY(DELAY_TIME);
        SCL = 0;
        if (F0 == 1)
        {
            b = b << 1;
            b = b | 0x01;
        }
        else
            b = b << 1;
    }
    return b;
}

//----write One Byte of Data,Data from MASTER to the SLAVER----
//主机向从机中地址为"addr"的寄存器发送一个字节数据
void Write_One_Byte(uchar addr, uchar thedata) //Write "thedata" to the SLAVER's address of "addr"
{
```

```
    bit acktemp = 1;
    I2C_Start();    //IIC START
    WriteI2CByte(0xFE << 1 + 0);    //IIC WRITE operation, SLAVER address bit: 0xFE
    acktemp = Check_Acknowledge(); //从机的写地址为 0xFE << 1
    WriteI2CByte(addr);    //address 为从机中某一寄存器的地址
    acktemp = Check_Acknowledge();
    WriteI2CByte(thedata); //thedata 为需要发送的一个字节数据
    acktemp = Check_Acknowledge();
    I2C_Stop();    //IIC STOP
}

//----Read One Byte of Data,Data from SLAVER to the MASTER----
//主机从从机中地址为"addr"的寄存器读出一个字节数据
uchar Read_One_Byte(uchar addr)
{
    bit acktemp = 1;
    uchar mydata;

    I2C_Start();
    WriteI2CByte(0xFE << 1 + 0);    //IIC WRITE operation, SLAVER address bit: 0xFE
    acktemp = Check_Acknowledge(); //从机的写地址为 0xFE << 1
    WriteI2CByte(addr);
    acktemp = Check_Acknowledge();
    I2C_Start();
    WriteI2CByte(0xFE << 1 + 1);    //IIC READ operation, SLAVER address bit: 0xFE
    acktemp = Check_Acknowledge(); //从机的读地址为 0xFE << 1 + 1
    mydata = ReadI2CByte();    //No ACK is required after this statement 此语句之后无需 ACK
    I2C_Stop();
    return mydata;
}

//----Delay_ms----
void Delay_xms(uint x) //延时 x 毫秒
{
    uint i, j;
    for (i = 0; i < x; i++)
        for (j = 0; j < 112; j++)
            ;
}

//----The main function----
void main(void)
```



```
{
    uchar temp; //temporary variable used to count the times of reading Sco bit
    //临时变量，用于计数读取 Sco 位的次数
    uchar pressure_H, pressure_M, pressure_L, temperature_H, temperature_L;
    //temporary variables of pressure and temperature
    //临时变量，用于保存从传感器中读出的与压力和温度相关的寄存器的数值
    long int pressure_adc, temperature_adc;
    //The value of pressure and temperature converted by the sensor's ADC
    //临时变量，用于保存传感器 ADC 转换后的压力值和温度值
    long float pressure, temperature;
    //The calibrated value of pressure and temperature
    //用于保存校准后的压力值和温度值
    Delay_xms(1000); //delay 1000ms 延时 1 秒

    while (1)
    {
        Write_One_Byte(0x30, 0x0A);
        //indicate a combined conversion (once temperature conversion immediately followed by once
        //sensor signal conversion)
        //0x30 里写入测量命令，000：单次温度测量；001：单次压力测量；010：组合：单次压力和温度
        //测量；011：休眠方式（以一定的时间间隔执行组合模式测量）
        while ((Read_One_Byte(0x30) & 0x08) > 0)
        //Judge whether Data collection is over 判断数据采集是否结束
        {
            Delay_xms(5); //delay 5ms 延时 5ms
            if(++temp > 4) //If data collection is not complete within 20ms, exit
                break; //如果 20ms 内还未完成数据采集，则退出
        }

        pressure_H = Read_One_Byte(0x06);
        pressure_M = Read_One_Byte(0x07);
        pressure_L = Read_One_Byte(0x08);
        // Read ADC output Data of Pressure 读取保存压力值的 3 个寄存器的值
        pressure_adc = pressure_H * 65536 + pressure_M * 256 + pressure_L;
        //Compute the value of pressure converted by ADC 计算传感器 ADC 转换后的压力值

        temperature_H = Read_One_Byte(0x09);
        temperature_L = Read_One_Byte(0x0a);
        //Read ADC output data of temperature 读取保存温度值的 2 个寄存器的值
        temperature_adc = temperature_H * 256 + temperature_L;
        //Compute the value of temperature converted by ADC 计算传感器 ADC 转换后的温度值
    }
}
```

```
pressure = pressure_adc * PARA_A + PARA_B; //计算最终校准后的压力值, 单位为 mmH2O
//The conversion formula of calibrated pressure, its unit is mmH2O

if (temperature_H >= 128)
    temperature = (temperature_adc - 65536) / 256; //单位为摄氏度
else
    temperature = temperature_adc / 256; //单位为摄氏度
//The conversion formula of calibrated temperature, its unit is Centigrade 计算最终校准后的温度值

Delay_xms(1000); //delay 1000ms
}
}
```