

## 940nm 15mW VCSEL with Photo Diode VP-0940C-015M-XX-1A0

### Features

- Single wavelength
- High sensitivity photodiode integrated
- Low wavelength drift
- Oxide isolation technology
- Low threshold current
- High reliability
- Easy to collimate

### Applications

- Proximity sensors
- Lidars
- Laser curtain
- Particulate matter sensors
- Medical applications
- Laser distance meter
- Liquid sensors
- Positioning applications

### PRODUCT IDENTIFY

Part Number	Description
VP-0940C-015M-XX-1A0	940nm 15mW VCSEL diode with Photodiode

### CODE RULES

e.g. *VP-0940C-015M-XX-1A0*

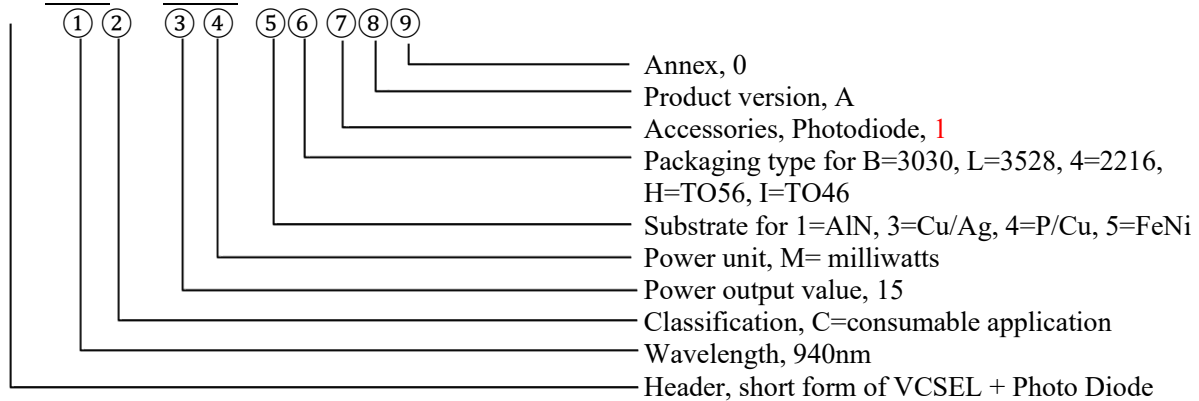

Photodiode	Range	filter	substrate	responsivity
1	400-1100 nm	no	Si	0.97@850nm
2	870-970nm	yes	Si	0.98@940nm

### I. Absolute maximum ratings

Parameter	Symbol	Rating	Unit
Case Operating Temp	Top	-40 to 70	°C
Storage Temp	Tsto	-40 to 85	°C
Reflow Soldering Temperature	Tsdr	260°C(10s)	°C
Reverse Voltage	Vr	5	V
Maximum Pulsed Current	Imax	20 (1% duty cycle)	mA
ESD exposure (Human body) model	ESD	2-4K (Class 2)	V
ESD exposure (Machine) Model	ESD	200-400 (Class B)	V

#### Note:

1. Stresses greater than those listed under “Absolute Maximum Ratings” may cause permanent damage to the device. This is a stress rating only and functional operation of the device at these or other conditions above those indicated in the operations section for extended periods of time may affect reliability.
2. In its maximum rating diode laser operation could damage its performance or cause potential safety hazard such as equipment failure.

3. Electrostatic discharge is the main reason for the laser fault of the diode. Take effective precautions against ESD. When dealing with laser diodes, use the wrist strap, grounding work surface and strict antistatic technology.

## II. Optical-electrical characteristics @25°C (0.1ms pulse width, 1% duty cycle)

Parameters	Conditions	Symbol	Unit	Min.	Typ.	Max.
Optical Power	$I_F=14\text{mA}$	$P_o$	mW	-	15	-
Threshold Current	-	$I_{th}$	mA	-	0.8	-
Forward Current	-	$I_F$	mA	-	14	-
Power conversion efficiency	$I_F=14\text{mA}$	$\eta$	%	-	40	43
Slope efficiency	$P_o=15\text{mW}$	-	mW/mA	-	1.13	-
Peak Wavelength	$I_F=14\text{mA}$	-	nm	930	940	950
Laser Forward Voltage	$I_F=14\text{mA}$	$V_f$	V	-	2.67	-
Series Resistance	$I_F=14\text{mA}$	R	$\Omega$	-	60	-
Beam Angle (FWHM)	$I_F=14\text{mA}$	-	Degrees	-	16	-
Wavelength Temp. drift	$I_F=14\text{mA}$	-	nm/°C	-	0.07	-
Emission area	-	-	um	-	$\Phi 12$	-
Rise/Fall time	-	-	ps	-	80	-
Soldering Temperature	AlN, P/Cu, FeNi	-	°C	-	-	260(10s)
	Cu/Ag	-	°C	-	-	180(10s)
Substrate	AlN, Cu/Ag, P/Cu, FeNi					

### Photodiode:

Parameters	Conditions	Symbol	Unit	Min.	Typ.	Max.
Forward Voltage	$I_F=10\text{mA}$ , $E_e=0\text{mW/cm}^2$	$V_F$	V	0.5	-	1.3
Reverse Breakdown Voltage	$I_{BR}=10\text{uA}$ , $E_e=0\text{mW/cm}^2$	$V_{BR}$	V	35	-	-
Reverse Dark Current	$V_R=10\text{V}$ , $E_e=0\text{mW/cm}^2$	$I_D$	nA	-	-	10
Light Current	$V_R=5\text{V}$ , $1\text{mW/cm}^2@940\text{nm}$	-	uA	-	2	-
Junction Capacitance	$V_R=3\text{V}$ , $F=1\text{MHz}$	$C_J$	pF	-	0.5	-
Rise time	$V_R=10\text{V}$	$T_r$	ns	-	1.7	-
Active area	-	-	mm	-	$0.26 \times 0.26$	-

**Note:** Electro-Optical Characteristic with a package or diffuser would require further evaluation. Values are based on limited sample size and estimated values.

## III. LIV Graph, Wavelength, and Relative responsivity

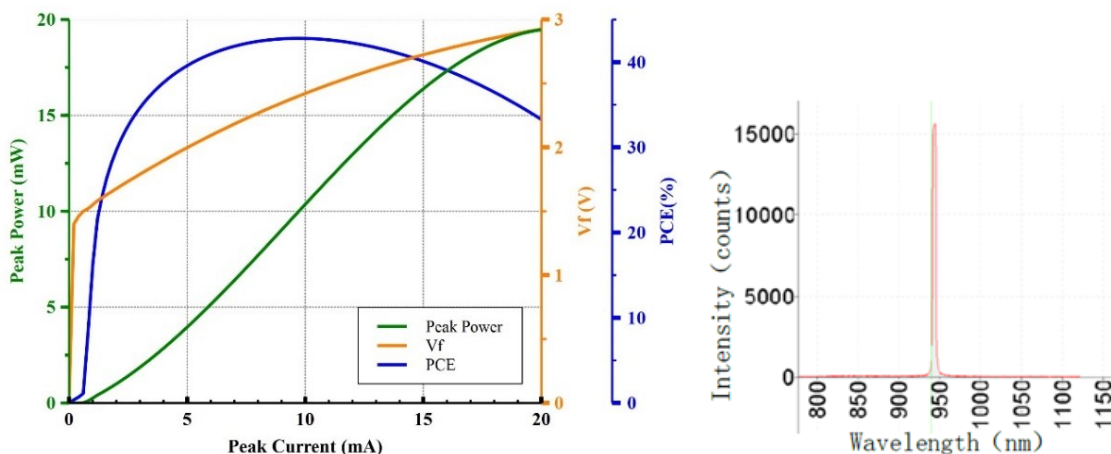

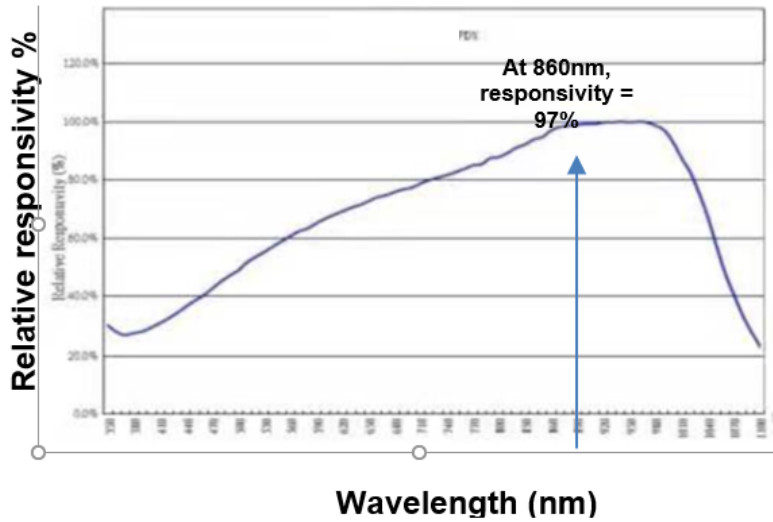

#### IV. Mechanical Schematics (unit: mm)

VP-0940C-015M-14-1A0 (substrate AlN, Package 2216 with PD)

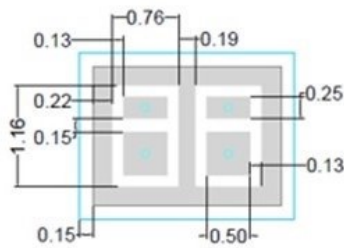

TOP VIEW

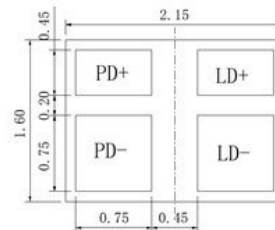

Bottom View

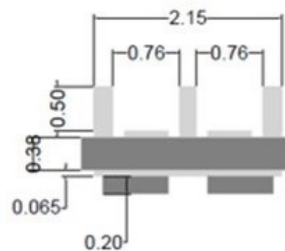
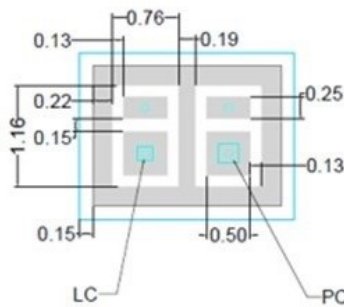

VP-0940C-015M-3B-1A0 (substrate Cu/Ag, Package 3030 with PD)

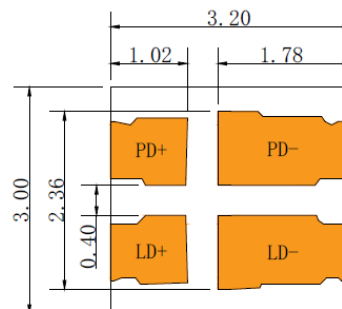
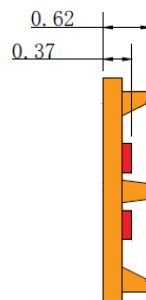
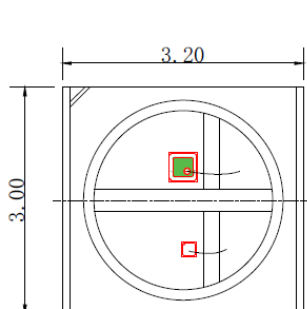

**VP-0940C-015M-4L-1A0 (substrate P/Cu, Package 3528 with PD)**

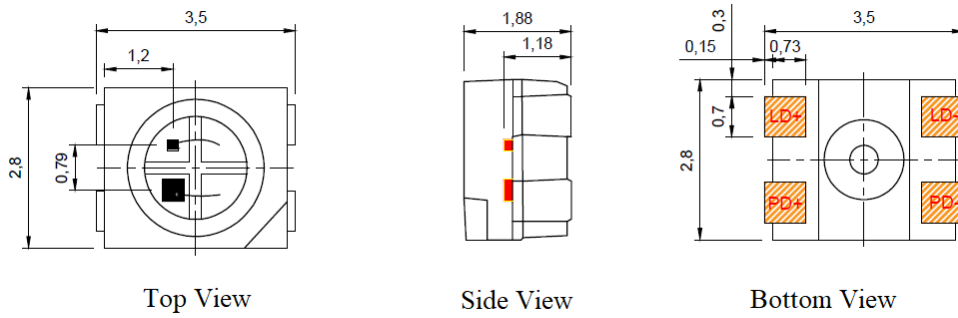

**VP-0940C-015M-5I-1A0 (substrate NiFe, Package TO46 with PD)**

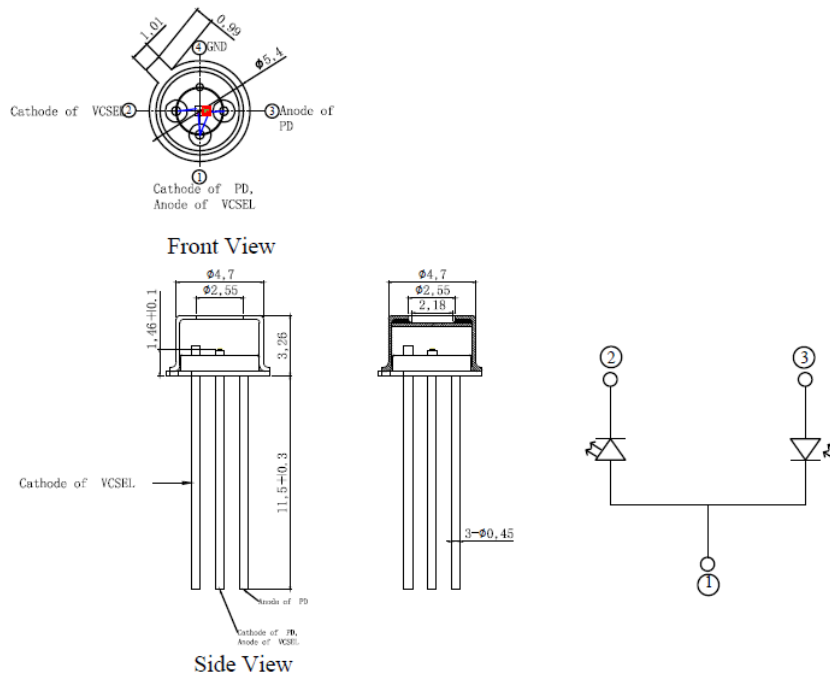

**VP-0940C-015M-5H-1A0 (substrate NiFe, Package TO56 with PD)**

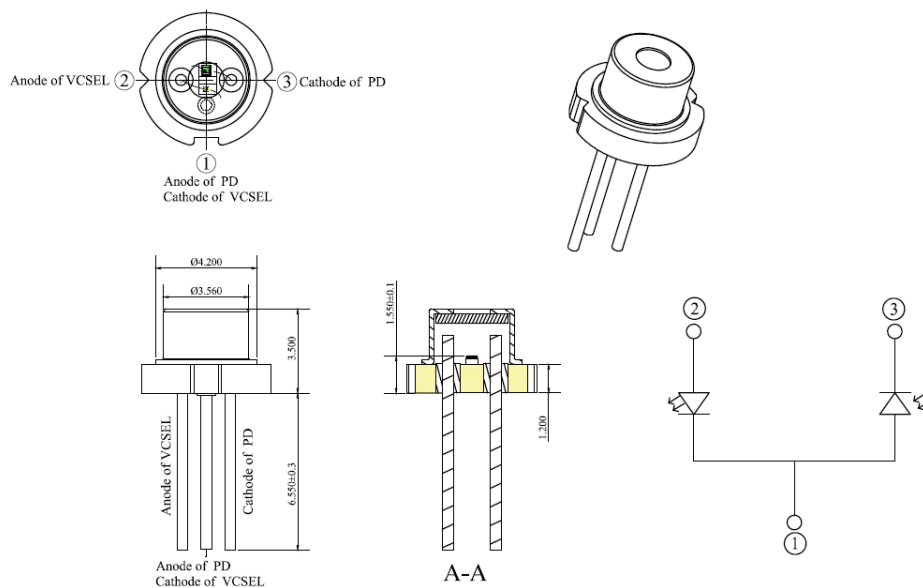

**Note:** The green arrow represents the direction of the diffuser. There may be some changes between sample and drawing, thus, the actual spec please refer to the sample that you received. And if any question please contact us.

## V. SMT reflow soldering curve

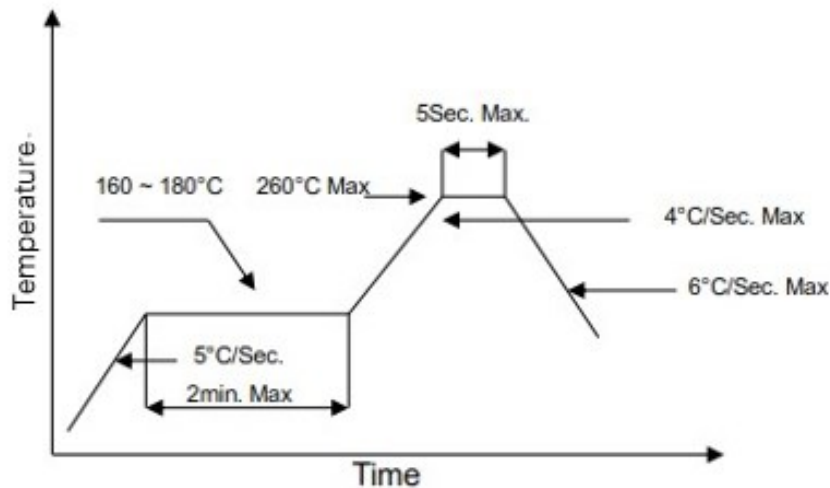

Note: Reflow soldering can be operated only one time. During the temperature ramp-up, no forces may be exerted on the VP which could deform or damage them. After soldering completed, please also do not process until the product temperature ramp down to room temperature.

## VII. Treatment and protection measures

### Soldering precautions

The temperature of soldering iron must be controlled under 300°C during manual soldering. Also, VCSEL can be only soldered one time with the soldering time less than 3s. But, It is very hard to control the soldering temperature and homogenize solder paste because of the smaller size of VCSEL. In addition, it is easy to damage VCSEL structure even causes VCSEL losing efficacy. So, we advise you to use re-flow soldering machine for operation.

### Storage precautions

Our products were sealed by aluminum foil bag attaching packed desiccant, they are moisture proof and anti-static. Please handle these gently to avoid damage. At the same time, please be ready for storage and take some moisture-proof measures to keep VCSEL away from dampness that may causes reliability failure.

Before opening, VCSEL must be saved for at least 90 days below 30°C with 60% RH.

After opening, VCSEL must be kept in an environment that temperature lower than 30°C and humidity lower than 60% RH and used up within 24 hours. When the storage humidity reaches and exceeds 60%, the products must be dehumidified at 60 °C for more than 24 hours before use.

### Others

1. Please use solder paste to cure the laser diode.
2. Please make sure that the heat of VP has been completely conducted to metal shell, to avoid affecting the optical power output.
3. This VP can be only used in constant voltage and current.
4. Operating voltage and current, refer to the table in paragraph II.
5. Please do not aim the laser to people or animal.
6. You can observe the laser spot through an image monitoring equipment.
7. Please do not touch VP surface by naked hands or squeeze the sealant on VP surface, or it may cause wrong optical angle and distorted laser spot, even damage the VP.
8. Please use ceramic suction nozzle to such on the VP, so as to avoid VP sticking to the

nozzle.

9. Please add a 0.02 s blowing action after locating the laser diode to aluminum substrate.

### VIII. Revision history

Revision	Date	Description
V.01	2022/05/06	The first official edition (VC4.5-1)
V.02	2023/01/18	The 2nd official edition (VC4.5-1)

\*\*Brightlaser reserves the right to make modification at any time due to improved design from time to time, the merit behind is to supply the best product possible

Laser diode product components are intended for use in a user-devised end system. However, these products are capable of emitting laser radiation. Extreme care must be exercised during their operation. Only persons familiar with the appropriate safety precautions should operate a laser product. Directly viewing the laser beam or exposure to specular reflections must be avoided. Serious injury may result if any part of the body is exposed to the beam. The eye is extremely sensitive to the infrared radiation and therefore, proper eye wear must be worn at all times. Use of optical instruments with these products may increase eye hazard. Always wear eye protection when operating.

