

## 850nm 10mW VCSEL Diode VD-0850C-010M-XX-2A0

### FEATURES

- 850nm single longitudinal mode
- Low wavelength drift
- Oxide isolation technology
- Low threshold current
- Small emission area
- Easy to collimate
- Modulation and width >2GHz

### APPLICATIONS

- Proximity sensors
- Consumer electronics
- Active optical cables
- Medical applications
- Range finder sensors

Part Number	Description
VD-0850C-010M-XX-2A0	850nm 10mW VCSEL Diode

### PRODUCT IDENTIFY

#### Code Rules

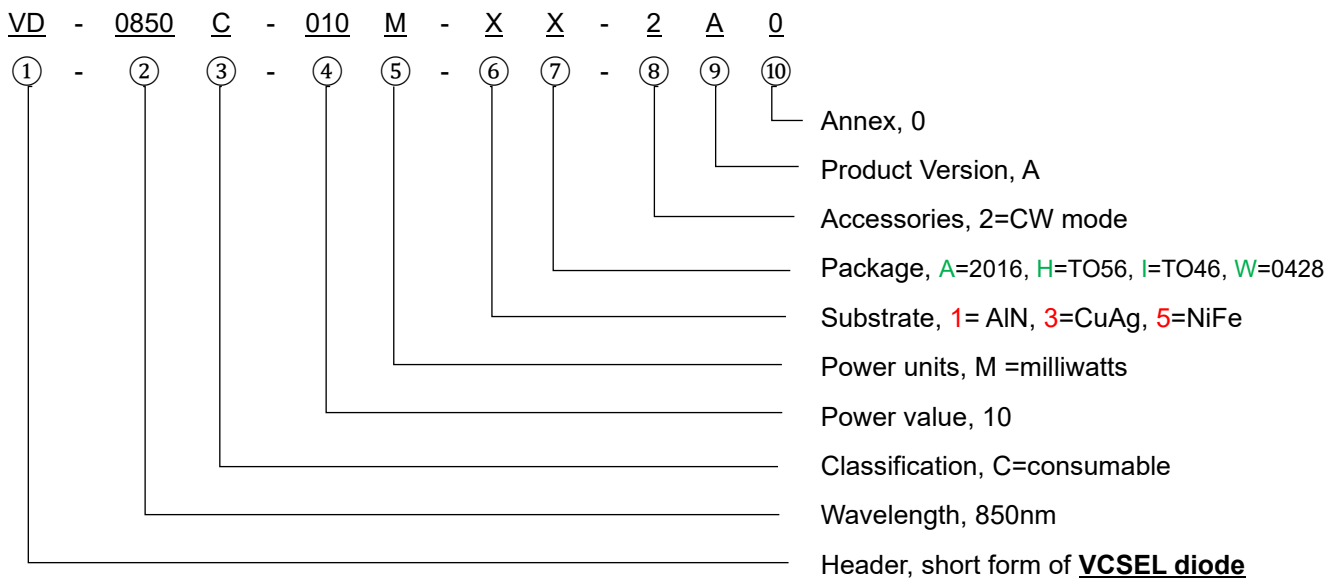

### I. Absolute maximum ratings

Parameter	Symbol	Rating	Unit
Case Operating Temperature	$T_{op}$	-25 to +70	°C
Storage Temperature	$T_{sto}$	-40 to +85	°C
Reflow Soldering Temperature	$T_{sdr}$	260°C (10s)	\
Reverse Voltage	$V_r$	5	V
Maximum Continuous Current	$I_{max}$	20	mA
ESD exposure (Human body) model	ESD	2k-4k (Class 2)	V
ESD exposure (Machine) Model	ESD	200-400 (Class B)	V

Note:

1. Stresses greater than those listed under "Absolute Maximum Ratings" may cause permanent damage to the device. This is a stress rating only and functional operation of the device at these or other conditions above those indicated in the operations section for extended periods of time may affect reliability.
2. In its maximum rating diode laser operation could damage its performance or cause potential safety hazard such as equipment failure.
3. Electrostatic discharge is the main reason for the laser fault of the diode. Take effective precautions against ESD. When dealing with laser diodes, use the wrist strap, grounding work surface and strict antistatic technology.

## II. Optical-electrical characteristics @25°C , CW mode

Parameters		Symbol	Conditions	Min.	Typ.	Max.	Unit
Optical Power Output		P <sub>o</sub>	I <sub>F</sub> =11mA	-	10	12	mW
Threshold Current		I <sub>th</sub>	-	-	0.5	-	mA
Forward Current		-	-	-	11	-	mA
Slope Efficiency		-	-	-	1.0	-	mW/mA
Power Conversion Efficiency		η	-	-	38	-	%
Peak Wavelength		λ <sub>P</sub>	P <sub>o</sub> =10mW	840	850	860	nm
Laser Forward Voltage		V <sub>F</sub>	I <sub>F</sub> =11mA	-	2.5	2.7	V
Series Resistance		R <sub>S</sub>	I <sub>F</sub> =11mA	-	60	-	Ω
Emission area		-	-	-	Φ12	-	um
Beam Angle	(1/e <sup>2</sup> )	θ	I <sub>F</sub> =11mA	-	23	-	Degrees
	FWHM	θ	I <sub>F</sub> =11mA	-	18	-	
Wavelength Temp. Drift		∂λP/∂T	I <sub>F</sub> =11mA	-	0.07	-	nm/°C
Soldering Temperature		-	AlN , FeNi Alloy	-	-	260(10s)	°C
		-	Cu/Ag	-	-	180(10s)	°C
Substrate		AlN, Cu/Ag, FeNi Alloy					

**Note:** Electro-Optical Characteristic with a package or diffuser would require further evaluation. Values are based on limited sample size and estimated values.

### III. Typical Performance

#### LIV curve

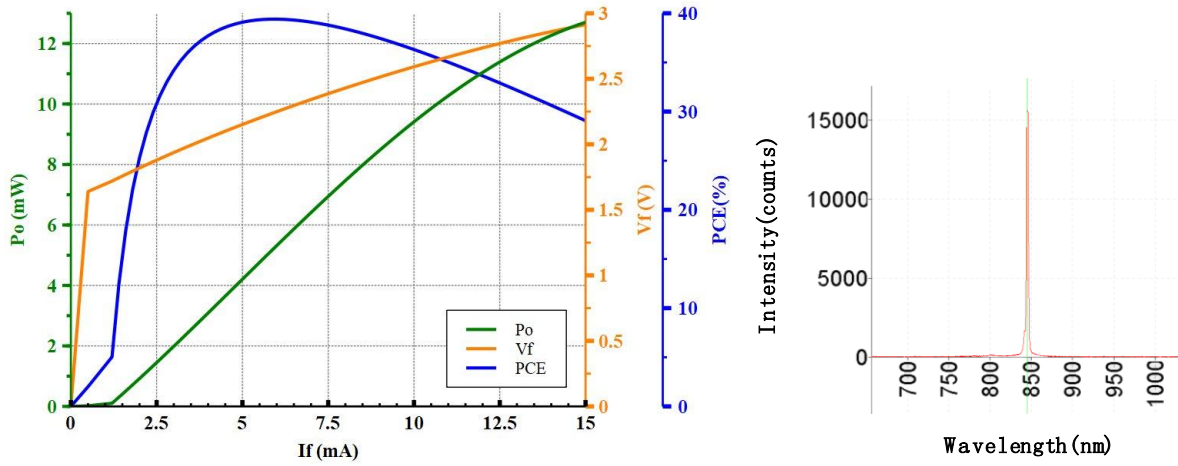

#### Note:

- LIV graph was measured at 25 °C (left); power output, voltage and power conversion efficiency variation trend with changed operating temperature (right, normalized).
- Forward Voltage (VF) measurement allowance is  $\pm 0.1$  V.
- Peak Wavelength ( $\lambda_P$ ) measurement allowance is  $\pm 1.5$  nm.
- Others measurement allowance is  $\pm 10\%$ .

### IV. Mechanical Schematics

VD-0850C-010M-3A-0A0 with Substrate 3=CuAg and Package A=2016 (unit: mm)

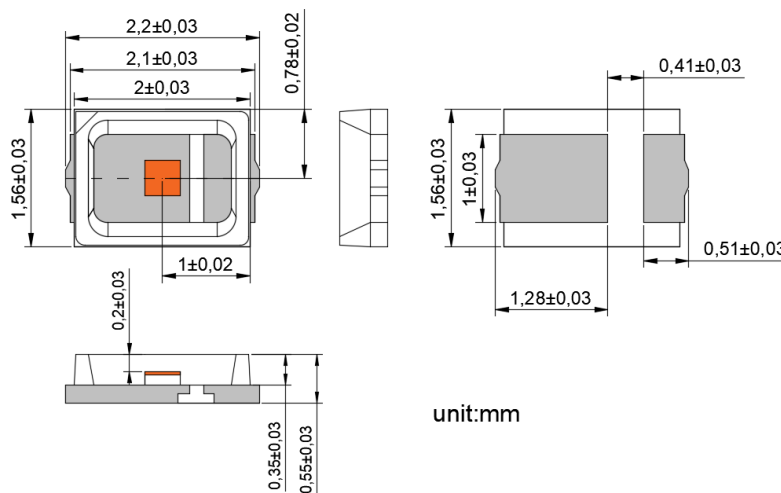

unit:mm

VD-0850C-010M-1A-0A0 with Substrate 1=AIN and Package A=2016 (unit: mm)

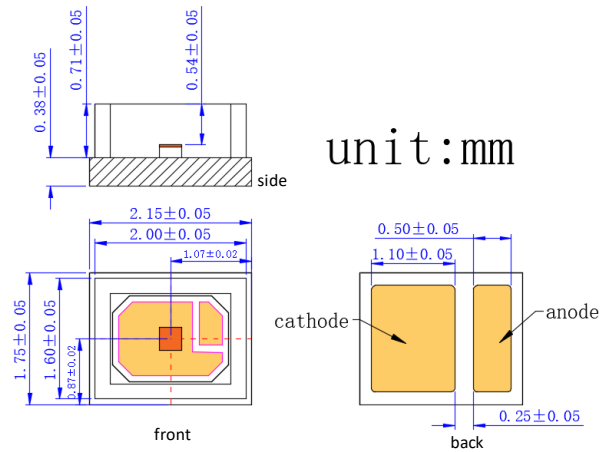

VD-0850C-010M-5H-0A0 with Substrate 5=NiFe and Package H=To56 (unit: mm)

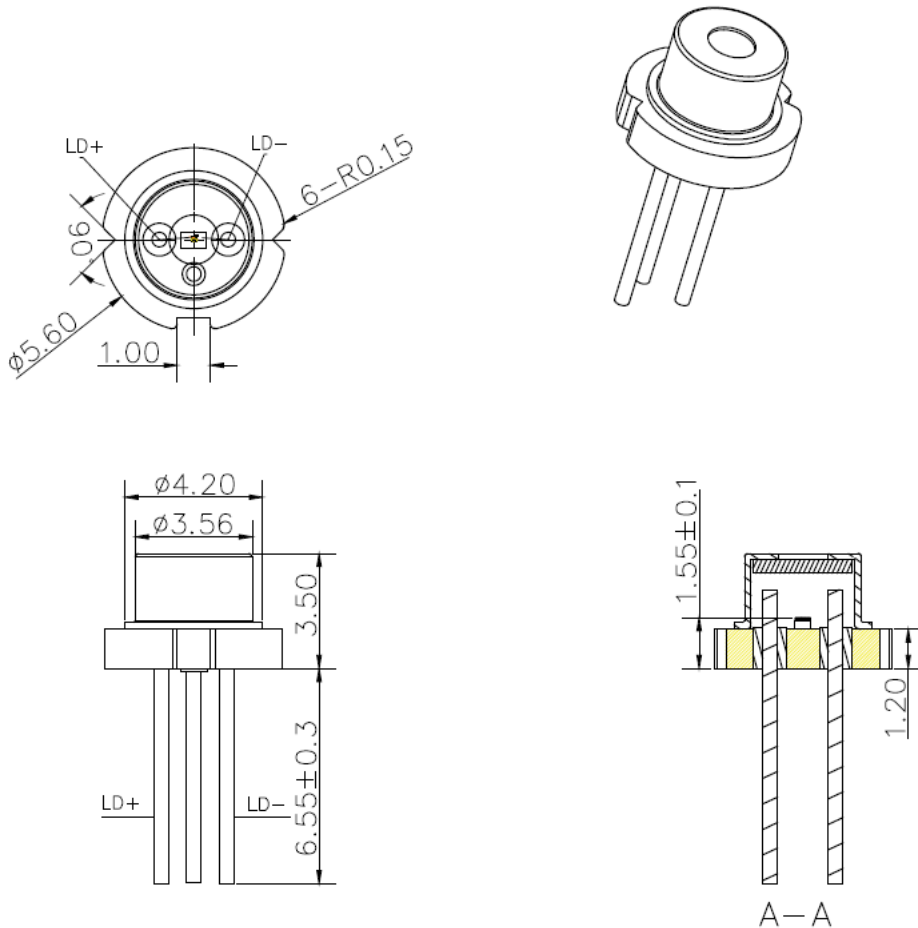

VD-0850C-010M-5I-0A0 with Substrate 5=NiFe and Package I=To46 (unit: mm)

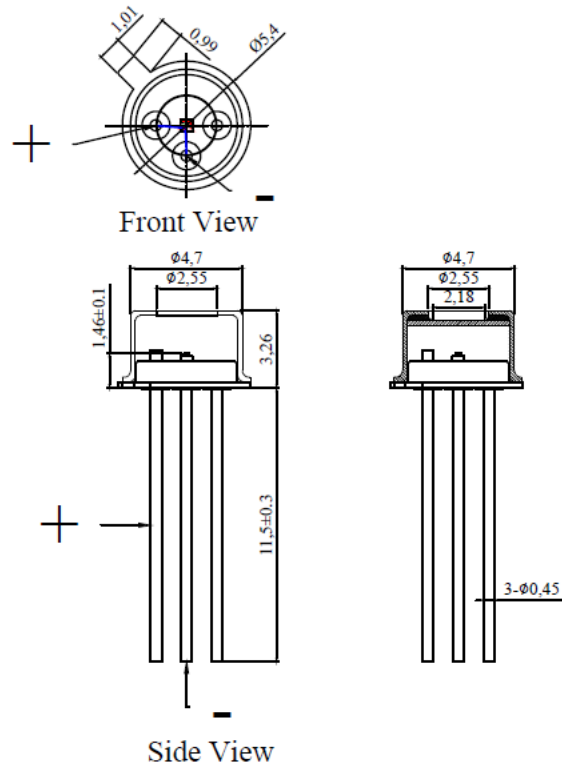

VD-0850C-010M-3W-0A0 with Substrate 3=CuAg and Package Plastic Dip W=0428 (unit: mm)

(Remarks: Operating only in pulsed mode)

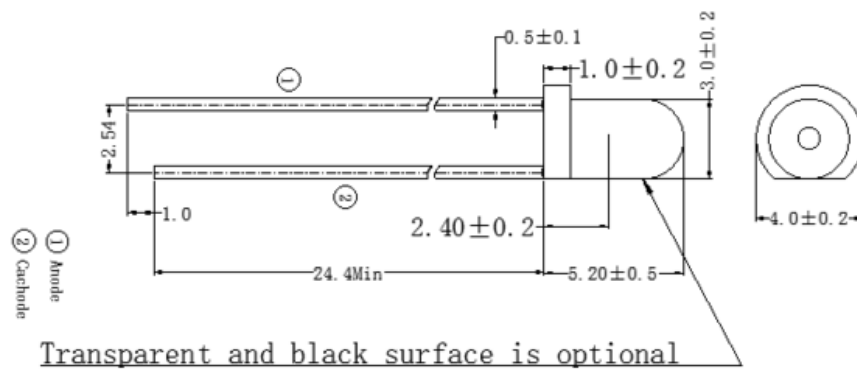

**Note:** There may be some changes between sample and drawing · thus · the actual spec please refer to the sample that you received. And if any inquires please contact us.

## V. SMT Reflow Soldering Curve

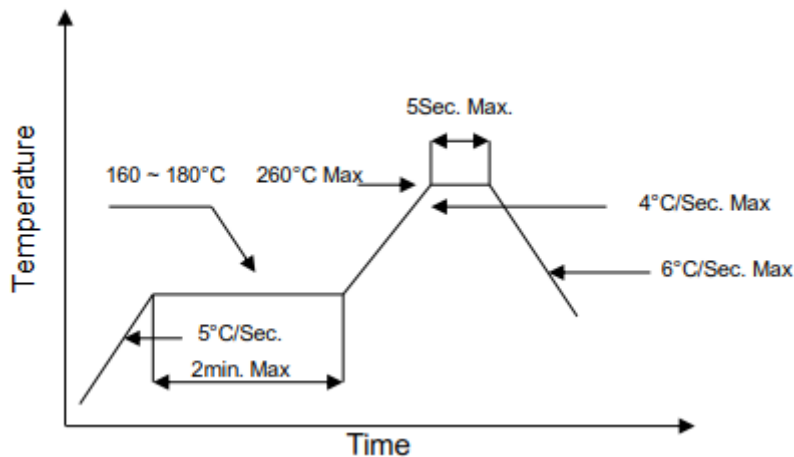

**Note:** Reflow soldering can be operated only one time. During the temperature ramp-up, no forces may be exerted on the diode which could deform or damage them. After soldering completed, please also do not process until the product temperature ramp down to room temperature.

## VI. Treatment and protection measures

### Soldering precautions

The temperature of soldering iron must be controlled under 300°C during manual soldering. Also, VCSEL can be only soldered one time with the soldering time less than 3s. but, it is very hard to control the soldering temperature and homogenize solder paste because of the smaller size of VCSEL. In addition, it is easy to damage VCSEL structure even causes VCSEL losing efficacy. So, we advise you to use re-flow soldering machine for operation.

### Storage precautions

Our products were sealed by aluminum foil bag attaching packed desiccant, they are moisture proof and anti-static. Please handle these gently to avoid damage. At the same time, please be ready for storage and take some moisture-proof measures to keep the diode away from dampness that may causes reliability failure.

Before opening, the diode must be saved for at least 90 days below 30 °C with 60% RH.

After opening, the diode must be kept in an environment that temperature lower than 30 °C and humidity lower than 60% RH and used up within 24 hours. When the storage humidity reaches and exceeds 60%, the products must be dehumidified at 60 °C for more than 24 hours before use.

### Others

1. Please use solder paste to cure the laser diode.
2. Please make sure that the heat of the diode has been completely conducted to metal shell, to avoid affecting the optical power output.
3. This diode can be only used in constant voltage and current.
4. Operating voltage and current, refer to the table in paragraph II.
5. Please do not aim the laser to people or animal.
6. You can observe the laser spot through an image monitoring equipment.

7. Please do not touch the diode surface by naked hands or squeeze the sealant on the diode surface, or it may cause wrong optical angle and distorted laser spot, even damage the diode.
8. Please use ceramic suction nozzle to absorb the diode, to avoid the diode sticking to the nozzle.
9. Please add a 0.02 s blowing action after locating the laser diode to aluminum substrate.

## VII. Revision History

Revision	Date	Description
V.01	2021/05/20	The first official edition [VC3.13-1]
V.02	2021/08/19	Update TO46 & TO56 Package

**Note:** Brightlaser reserves the right to make modification at any time due to improved design from time to time, the merit behind is to supply the best product possible.

Laser diode product components are intended for use in a user-devised end system. However, these products are capable of emitting laser radiation. Extreme care must be exercised during their operation. Only persons familiar with the appropriate safety precautions should operate a laser product. Directly viewing the laser beam or exposure to specular reflections must be avoided. Serious injury may result if any part of the body is exposed to the beam. The eye is extremely sensitive to the infrared radiation and therefore, proper eye wear must be worn at all times. Use of optical instruments with these products may increase eye hazard. Always wear eye protection when operating.

