

# **K-Band Doppler Sensor Module**

RF Frequency: 24.05 to 24.25 GHz

## **Model No. NJR4266 series**

Frequency Line-up: J: 24.05 to 24.25 GHz  
F2: 24.15 to 24.25 GHz  
F3: 24.075 to 24.175 GHz

Antenna Type: A: TX/RX 1x1 (80°/80°, 7m)  
B: TX/RX 2x1 (80°/50°, 10m)  
C: TX/RX 4x1 (80°/28°, 14m)  
D: TX/RX 2x2 (50°/50°, 13m)

Interface Type: 1: UART  
2: Digital Output / Analog Range Setting

## **Specifications**

**Rev.07e August 19, 2020**

## **© Copyright**

**New Japan Radio Co., Ltd.  
Microwave Division**

-Notice of Proprietary Information-

Documents and contents are proprietary to New Japan Radio Co., Ltd.  
This publication and its contents may not be reproduced or distributed for any other purpose without the written permission of New Japan Radio Co., Ltd.

## 24GHz Microwave Intelligent Motion Sensor for Short Distance, Low Speed Applications with Low-profile and Low-power-consumption

NJR4266 is intelligent human motion sensor module that can detect objects moving at low speed like a pedestrian in a short distance range (7 to 14 m) by itself and it incorporates a 24 GHz band microwave circuit, antenna, signal processing circuit, and also MCU in a 17.2 x 27.3 x 5.2 mm low profile package. Signal processing of original technology greatly reduces false detection due to environmental noise, achieves stable detection results, and identifies directions of approach and separation. And also it has a function to reduce power consumption by sensitivity setting.

It has multiple antenna types so that users can select the optimum detection angle according to the application, and has UART and standalone (digital output / analog range setting) as interface type. It is possible to use in a wide range of applications form these lineups

### Features:

- Motion sensor using the 24GHz Microwave Doppler
- Antenna, Microwave RF circuit, IF amp, MCU and voltage regulator are integrated in a low-profile package (17.2 x 27.3 x 5.2 mm)
- Low-power-consumption  
ECO mode: Minimum 1.9 mA @ 3.3 V
- Sleep mode for reducing power when unnecessary
- Signal processing software for the steady sensing
  - Enhancing the signal from movement object and decreasing random noises
  - Decreasing the mutual interference between sensors
  - Identification of direction for movement object (approaching and leaving).
- Interface selectable from UART and digital output / analog sensitivity setting
- Selectable from 4 types of antenna types
  - 1 x 1 type (Angle: 80° / 80°, Distance: 7 m)
  - 2 x 1 type (Angle: 80° / 50°, Distance: 10 m)
  - 4 x 1 type (Angle: 80° / 28°, Distance: 14 m)
  - 2 x 2 type (Angle: 50° / 50°, Distance: 13 m)

### Applications:

- Various equipment control by human sensing
  - Lighting equipment
  - Safety and security sensor
  - Housing electric equipment
  - Energy saving management
  - Entrance and exit management
  - Hobby / robot

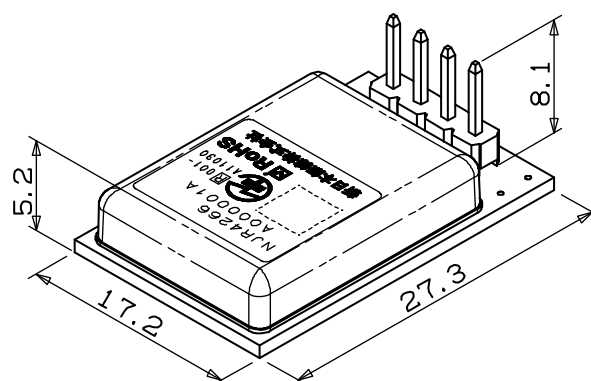

## Functional Block diagram:

- Type of UART

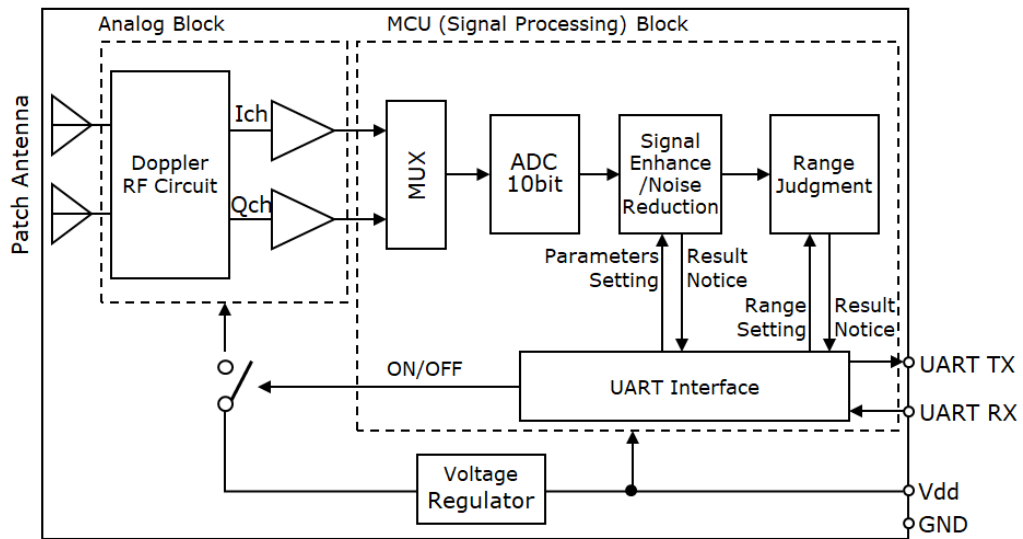

- Type of Digital Output / Analog Range Setting

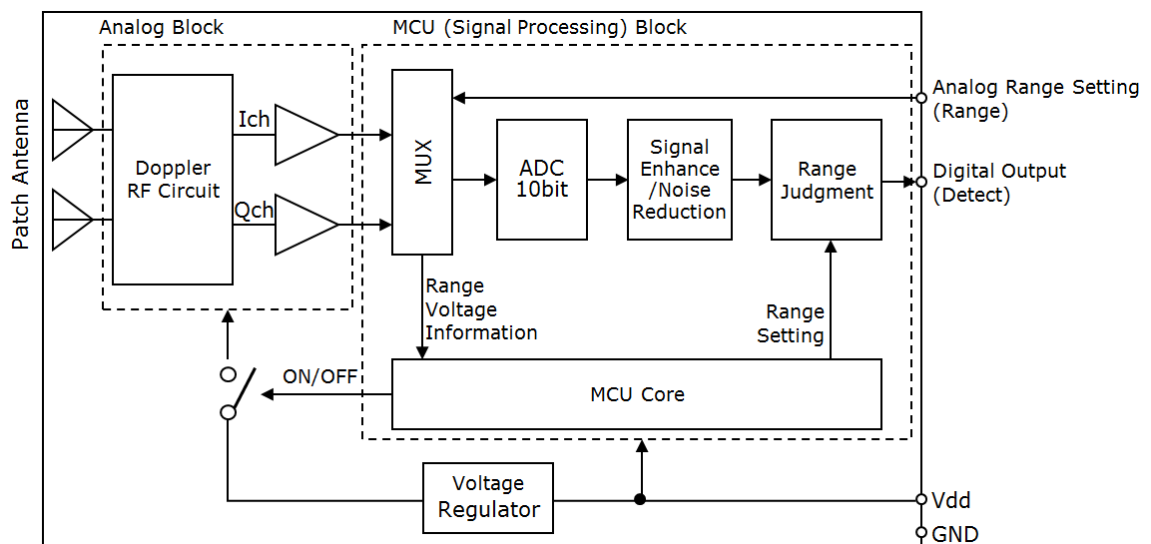

## Model Numbering System:

N J R 4 2 6 6 J A 1

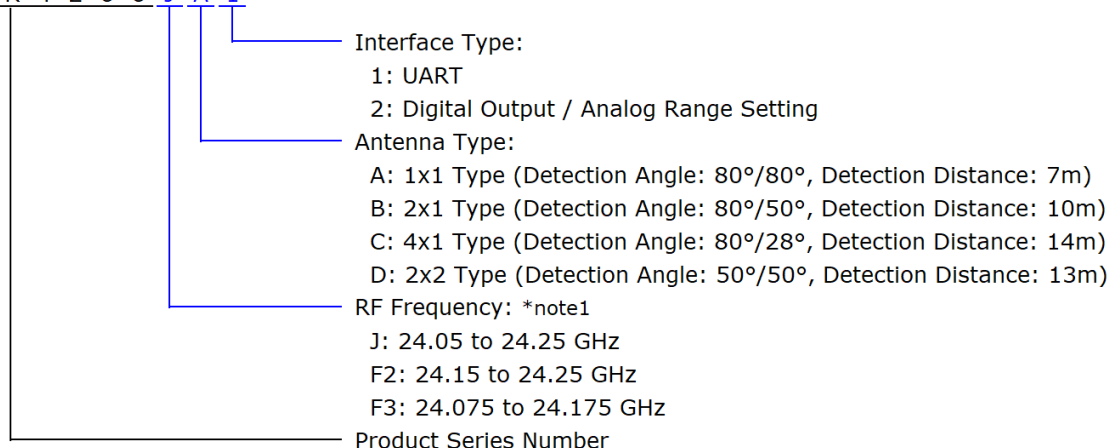

## Model List:

Model No.	RF Frequency	Antenna Type	Interface Type	Region / Regulations
NJR4266JA1	24.05 to 24.25 GHz (J type)	1x1 type (Angle: 80°/80°, Distance: 7m)	UART	JAPAN / MIC Technical Conformity ARIB STD-T73
NJR4266JA2		Digital Output / Analog Range Setting		
NJR4266JB1		2x1 type (Angle: 80°/50°, Distance: 10m)	UART	
NJR4266JB2		Digital Output / Analog Range Setting		
NJR4266JC1		4x1 type (Angle: 80°/28°, Distance: 14m)	UART	
NJR4266JC2		Digital Output / Analog Range Setting		
NJR4266JD1		2x2 type (Angle: 52°/60°, Distance: 13m)	UART	
NJR4266JD2		Digital Output / Analog Range Setting		
NJR4266F2A1	24.15 to 24.25 GHz (F2 type)	1x1 type (Angle: 80°/80°, Distance: 7m)	UART	All of EU regions / Radio Equipment Directive (RED) 2014/53/EU (CE Marking)
NJR4266F2A2		Digital Output / Analog Range Setting		
NJR4266F2B1		2x1 type (Angle: 80°/50°, Distance: 10m)	UART	
NJR4266F2B2		Digital Output / Analog Range Setting		
NJR4266F2C1		4x1 type (Angle: 80°/28°, Distance: 14m)	UART	
NJR4266F2C2		Digital Output / Analog Range Setting		
NJR4266F2D1		2x2 type (Angle: 50°/50°, Distance: 13m)	UART	
NJR4266F2D2		Digital Output / Analog Range Setting		
NJR4266F2A1	24.15 to 24.25 GHz (F2 type)	1x1 type (Angle: 80°/80°, Distance: 7m)	UART	US *note1 / FCC Section 15.249
NJR4266F2A2		Digital Output / Analog Range Setting		
NJR4266F2B1		2x1 type (Angle: 80°/50°, Distance: 10m)	UART	
NJR4266F2B2		Digital Output / Analog Range Setting		
NJR4266F3C1	24.075 to 24.175 GHz (F3 type)	4x1 type (Angle: 80°/28°, Distance: 14m)	UART	US / FCC *note1 Part 15.245
NJR4266F3C2		Digital Output / Analog Range Setting		
NJR4266F3D1		2x2 type (Angle: 50°/50°, Distance: 13m)	UART	
NJR4266F3D2		Digital Output / Analog Range Setting		

\*Note1) Contact NJR for FCC compliance status.

When using NJR4266 series under FCC regulation, please be sure to read and observe FCC Statement in appendix.

## Evaluation Kit:

The evaluation kit is available for NJR4266 series. The contents of the evaluation kit are as follows.

➤ **Evaluation Kit P/N.: NJR4266K**

➤ **Contents**

1. Evaluation Board (Functions are UART-to-USB convertor and analog threshold setting)
2. GUI Software
3. USB Cable

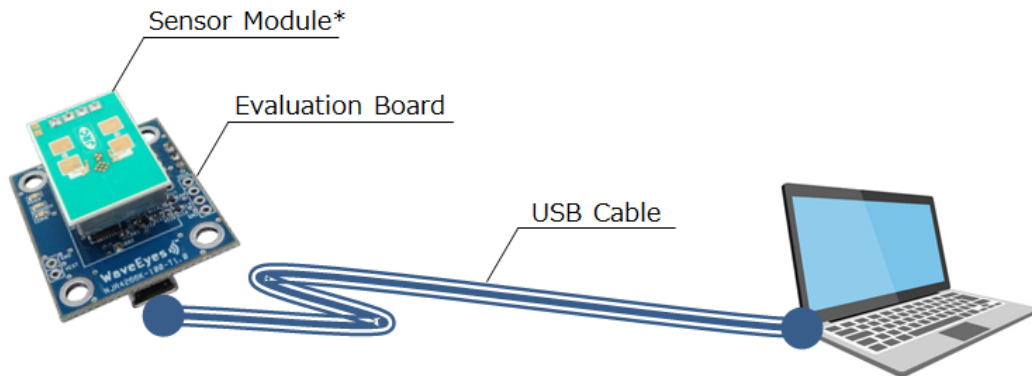

(\* ) The sensor module itself needs to be prepared separately.

## 1. Absolute Maximum Rating

ITEM	MIN.	TYP.	MAX.	UNITS	REMARKS
Supply Voltage	0	—	6.5	V	Vdd
1) Type of UART					
Source Current of UART TX Port	—	—	100	mA	
Sink Current of UART TX Port	—	—	100	mA	
Voltage of UART RX Port	-0.3	—	Vdd +0.3	V	
2) Type of Digital Output / Analog Range Setting					
Source Current of Detect Port	—	—	100	mA	
Sink Current of Detect Port	—	—	100	mA	
Voltage of Range Port	-0.3	—	Vdd +0.3	V	
Operating Temperature	-40	—	+85	°C	No Damage Condition. Refer to Section 9 as functional operating temperature.
Storage Temperature	-40	—	+85	°C	

## 2. Electrical Characteristics

Common measure condition Ta= +25 °C

ITEM	MIN.	TYP.	MAX.	UNITS	REMARKS
2.1. Power Supply					
2.1.1. Operating Voltage	3.0	3.3/5.0	5.25	V	
2.1.2. Operating Current (* depends on interface type )					
1) Type of UART					
i) Detection mode					
● CW mode	—	50	60	mA	
● Peak current of intermittent mode					
● Average current of ECO mode (@ Vdd = 3.3 V)					
Intermittent of 1 kHz	—	1.9	2.3	mA	Intermittent Operation Condition: 1 ms cycle, 11 us ON
Intermittent of 2 kHz	—	2.5	3.2	mA	Intermittent Operation Condition: 500 us cycle, 11 us ON
Intermittent of 3 kHz	—	3.0	3.8	mA	Intermittent Operation Condition: 333 us cycle, 11 us ON
Intermittent of 7 kHz	—	5.0	6.2	mA	Intermittent Operation Condition: 143 us cycle, 11 us ON
● Average current of ECO mode (@ Vdd = 5 V)					
Intermittent of 1 kHz	—	2.9	3.4	mA	Intermittent Operation Condition: 1 ms cycle, 11 us ON
Intermittent of 2 kHz	—	3.6	4.2	mA	Intermittent Operation Condition: 500 us cycle, 11 us ON
Intermittent of 3 kHz	—	4.0	4.7	mA	Intermittent Operation Condition: 333 us cycle, 11 us ON
Intermittent of 7 kHz	—	6.0	7.0	mA	Intermittent Operation Condition: 143 us cycle, 11 us ON
ii) Initialization mode					
● Peak Current	—	50	60	mA	
● Average Current (@ Vdd = 3.3 V)	—	1.9	2.3	mA	
● Average Current (@ Vdd = 5 V)	—	2.9	3.4	mA	
iii) Sleep mode					
● Operating Current (@ Vdd = 3.3 V)	—	—	1.0	mA	
● Operating Current (@ Vdd = 5 V)	—	—	1.0	mA	
2) Type of Digital Output / Analog Range Setting					
● Peak Current	—	50	60	mA	
● Average Current		1.9 to 60		mA	Depends on analog range setting and Vdd. Refer to figure 4.

ITEM	MIN.	TYP.	MAX.	UNITS	REMARKS
2.2. Characteristic of Input and Output Ports					
1) Type of UART					
Input Voltage of UART RX Port					
Range of High Level	0.8 *Vdd	—	Vdd	V	
Range of Low Level	0	—	0.2 *Vdd	V	
Output Voltage of UART TX Port					
Range of High Level	Vdd -0.6	—	Vdd	V	In case of 3.0 ≤ Vdd < 4.0V
	Vdd -1.5	—	Vdd	V	In case of 4.0 ≤ Vdd ≤ 5.25V
Range of Low Level	0	—	0.6	V	In case of 3.0 ≤ Vdd < 4.0V
	0	—	1.3	V	In case of 4.0 ≤ Vdd ≤ 5.25V
Source Current of UART TX port	—	—	10	mA	Condition to connect 1.0kΩ pull-up resistor
Sink Current of UART TX port	—	—	10	mA	Condition to connect 1.0kΩ pull-up resistor
2) Type of Digital Output / Analog Range Setting					
Input Voltage of Range Port					
Range of Input Voltage	0	—	Vdd	V	Refer to item 4.3 as Analog Range Setting
Output Voltage of Detection Port					
Range of High Level	Vdd -0.6	—	Vdd	V	In case of 3.0 ≤ Vdd ≤ 4.0V
	Vdd -1.5	—	Vdd	V	In case of 4.0 < Vdd ≤ 5.25V
Range of Low Level	0	—	0.6	V	In case of 3.0 ≤ Vdd ≤ 4.0V
	0	—	1.3	V	In case of 4.0 < Vdd ≤ 5.25V
Source Current of Detect port	—	—	10	mA	Condition to connect 1.0kΩ pull-up resistor
Sink Current of Detect port	—	—	10	mA	Condition to connect 1.0kΩ pull-up resistor



ITEM	MIN.	TYP.	MAX.	UNITS	REMARKS
<b>2.3. Sensor RF</b>					
Conformity Standard	<ul style="list-style-type: none"> <li>● MIC Technical Conformity (Japan): ARIB STD-T73</li> <li>● EU Regulation: Radio Equipment Directive 2014/53/EU</li> <li>● FCC Regulation: Section 15.245 or Section 15.249*note1</li> </ul>				
Operating Frequency					
J1 type	24.05	—	24.25	GHz	
F2 type	24.15	—	24.25	GHz	
F3 type	24.075	—	24.175	GHz	
Frequency Stability (Temp.)	—	+/-0.2	—	MHz/°C	Ta = -20 to +60 °C
Output Power	1.55	3.10	4.65	mW	
E.I.R.P. (Reference)					
1 x 1 antenna type	4.8 (6.9)	9.6 (9.8)	14.3 (11.5)	mW (dBm)	
2 x 1 antenna type	6.3 (8.0)	12.6 (11.0)	20.0 (13.0)	mW (dBm)	
4 x 1 antenna type	13.2 (11.2)	26.4 (14.2)	39.4 (15.9)	mW (dBm)	
2 x 2 antenna type	11.5 (10.7)	23.0 (13.6)	34.4 (15.3)	mW (dBm)	
2 <sup>nd</sup> Harmonics (E.I.R.P.)	—	—	-30	dBm	
<b>2.4. Antenna</b>					
1 x 1 antenna type					
-3dB beam width / Horizontal	—	80	—	deg.	
-3dB beam width / Vertical	—	80	—	deg.	
Side-lobe suppression / Horizontal	—	—	—	dB	No Side lobe
Side-lobe suppression / Vertical	—	—	—	dB	No Side lobe
2 x 1 antenna type					
-3dB beam width / Horizontal	—	80	—	deg.	
-3dB beam width / Vertical	—	50	—	deg.	
Side-lobe suppression / Horizontal	—	—	—	dB	No Side lobe
Side-lobe suppression / Vertical	—	—	—	dB	No Side lobe
4 x 1 antenna type					
-3dB beam width / Horizontal	—	80	—	deg.	
-3dB beam width / Vertical	—	28	—	deg.	
Side-lobe suppression / Horizontal	—	—	—	dB	No Side lobe
Side-lobe suppression / Vertical	—	13	—	dB	
2 x 2 antenna type					
-3dB beam width / Horizontal	—	50	—	deg.	
-3dB beam width / Vertical	—	50	—	deg.	
Side-lobe suppression / Horizontal	—	—	—	dB	No Side lobe
Side-lobe suppression / Vertical	—	—	—	dB	No Side lobe

\*Note1) Contact NJR for FCC compliance status.

## Antenna Pattern

### 1 x 1 Antenna Type

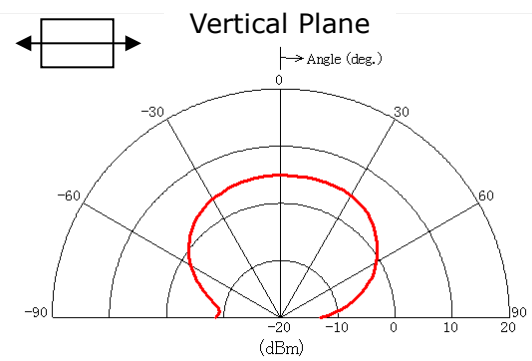
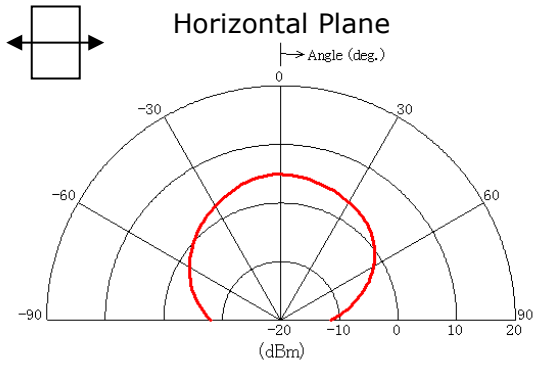

### 2 x 1 Antenna Type

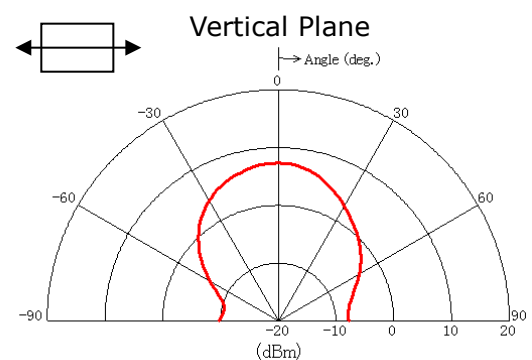
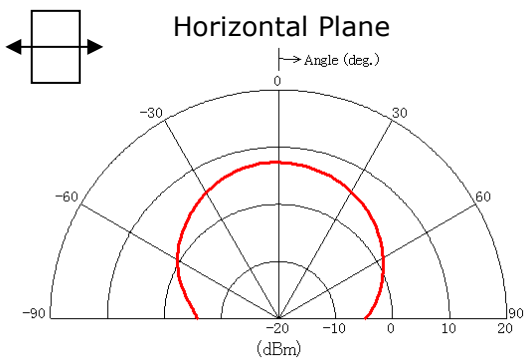

### 4 x 1 Antenna Type

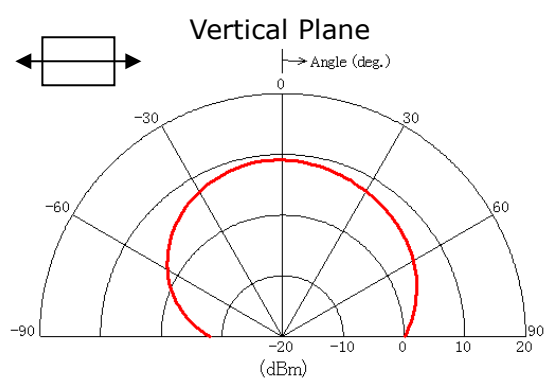
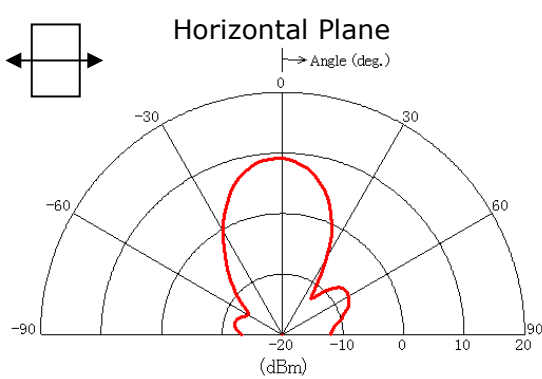

### 2 x 2 Antenna Type

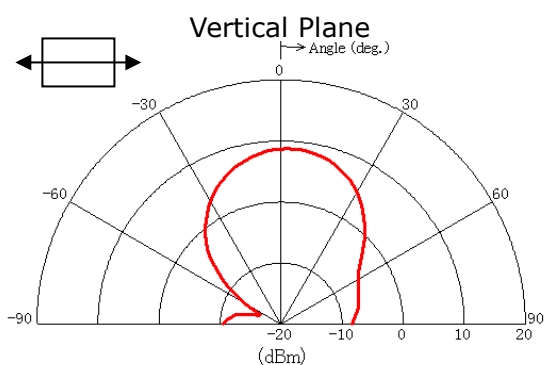
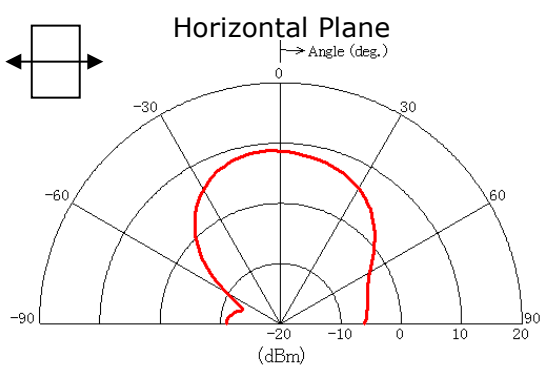

## 3. Sensing Specifications

### 3.1. Sensing Performance \*note1

Common measure condition Ta= +25 °C

ITEM	PERFORMANCE	UNITS	REMARKS
Speed Range of Target	0.25 to 1.0	m/sec.	
Maximum Detection Distance			
1 x 1 antenna type	7	m	* Design value
2 x 1 antenna type	10	m	
4 x 1 antenna type	14	m	* Design value
2 x 2 antenna type	13	m	* Design value

\*Note1) This is not the specification to guarantee the performance of this product. As for the specification of the product, the electric characteristic standard is applied. Sensing performance shown here is an example of the result of being likely to obtain it when this product is used on the following conditions. Actual sensing performance would be greatly different in each environment used. Please do enough confirmation in the environment actually used.

#### Definition of Sensing Performance

- \* Speed Range of Target: The range of the speed that the detection distance become 70 % of the detection distance of 0.5 m/s
- \* Maximum Detection Distance: Detectable distance that can be detected in front of sensor when a threshold value set to [999] or when VDD is added to a threshold setting terminal

#### Measurement condition of detection performance

- \* Temperature: Ta = +25 °C
- \* Target of Measurement: An adult of 170 cm / 70 kg approaching at the rate of 0.5 m/s from the front of sensor  
(Refer to figure 1 and figure 2)
- \* Installation of the Sensor: The sensor is installed as the antennas horizontal horizontally in a height of 1 m from the ground.  
(Refer to figure 1 and figure 2)

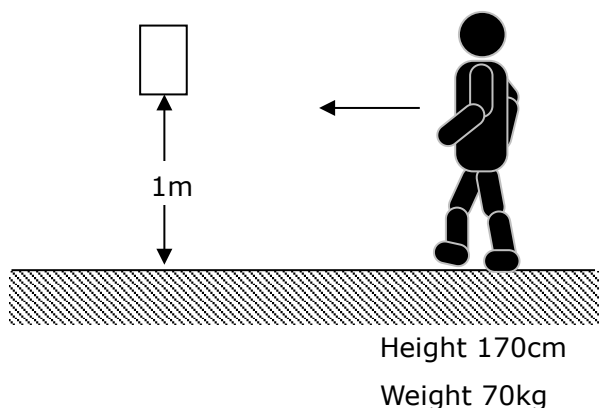

Fig. 1 Side View

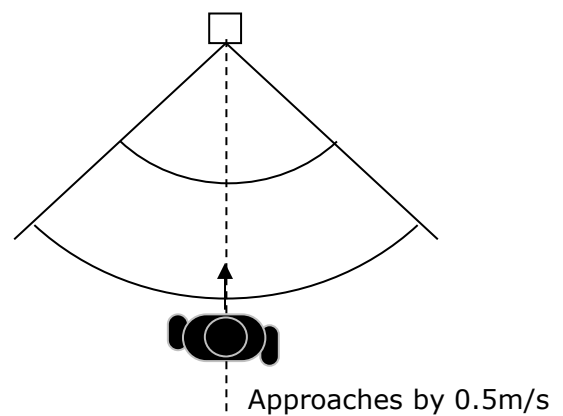

Fig. 2 Top View

## 3.2. Range Setting and Intermittent Operation Condition

Intermittent operation condition depends on range setting of detection distance.

### 3.2.1. Type of UART

The range setting can be changed by the command of UART and it is set with the ratio (%) to the maximum detection distance.

RANGE SETTING: $R_{Ratio}$ *note1	INTERMITTENT OPERATION CONDITION *note2
$1 \leq R_{Ratio} \leq 36$	Intermittent operation of 1 kHz: 1 ms cycle, 11 us ON
$37 \leq R_{Ratio} \leq 43$	Intermittent operation of 2 kHz: 500 us cycle, 11 us ON
$44 \leq R_{Ratio} \leq 48$	Intermittent operation of 3 kHz: 333 us cycle, 11 us ON
$49 \leq R_{Ratio} \leq 64$	Intermittent operation of 7 kHz: 147 us cycle, 11 us ON
$65 \leq R_{Ratio} \leq 100$	CW operation

\*Note1) The range setting is larger value of either the approaching and leaving setting.

\*Note2) The intermittent condition is automatically set by the range setting. Nevertheless it can also be arbitrarily changed by the command.

### 3.2.2. Type of Digital Output / Analog Range Setting

The range setting can be changed by the analog voltage and it is set with the ratio (%) to the maximum detection distance. The detail of the analog voltage for the range setting is mentioned in item 3.3.

RANGE SETTING: $R_{Ratio}$ (Vdd Ratio)	INTERMITTENT OPERATION CONDITION *note3
$1 \leq R_{Ratio} \leq 36$	Intermittent operation of 1 kHz: 1 ms cycle, 11 us ON
$36 < R_{Ratio} \leq 43$	Intermittent operation of 2 kHz: 500 us cycle, 11 us ON
$43 < R_{Ratio} \leq 48$	Intermittent operation of 3 kHz: 333 us cycle, 11 us ON
$48 < R_{Ratio} \leq 64$	Intermittent operation of 7 kHz: 147 us cycle, 11 us ON
$64 < R_{Ratio} \leq 100$	CW operation

\*Note3) The intermittent condition is automatically set by the range setting.

### 3.3. Analog Voltage for Range Setting (for only Type of Digital Output / Analog Range Setting)

The range setting is defined by the following equation:

$$\frac{R_{\text{Range}}}{R_{\text{max}}} = \frac{V_{\text{Range}}}{V_{\text{dd}}} \left( \frac{5.25}{V_{\text{dd}}} \right)^{(2/3)}$$

$R_{\text{Range}}$  : Setting of detection distance  
\*note1

$R_{\text{max}}$  : Maximum detection distance

$V_{\text{Range}}$  : Voltage of analog range setting

$V_{\text{dd}}$  : Voltage of power supply

The range setting against  $V_{\text{dd}}$  and  $V_{\text{Range}}$  is shown in figure 3.

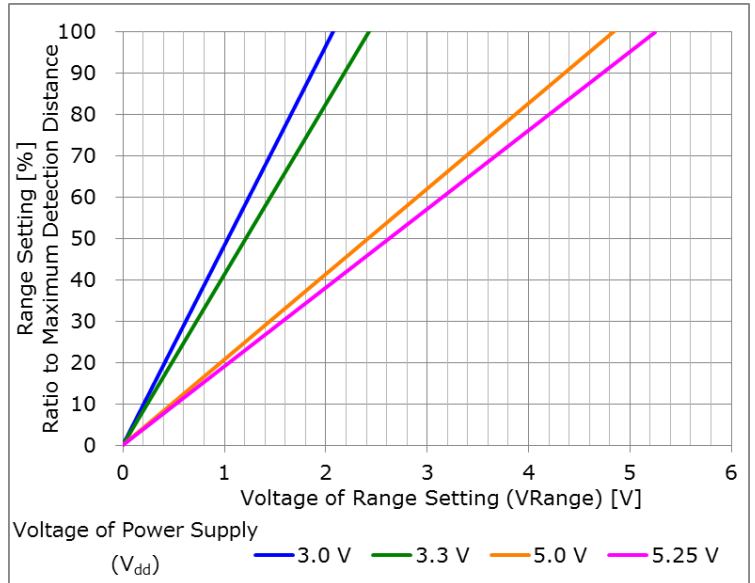

Fig. 3 Ratio of Range Setting against Voltage

\*Note1) Detection distance assumes the case that an adult of 170 cm / 70 kg approaches at the rate of 0.5 m/s from the front.

### 3.4. Correlation between Range Setting and Operating Current

The operating current depends on voltage of power supply ( $V_{\text{dd}}$ ) and range setting. The detail of the correlation is mentioned in figure 4 as reference.

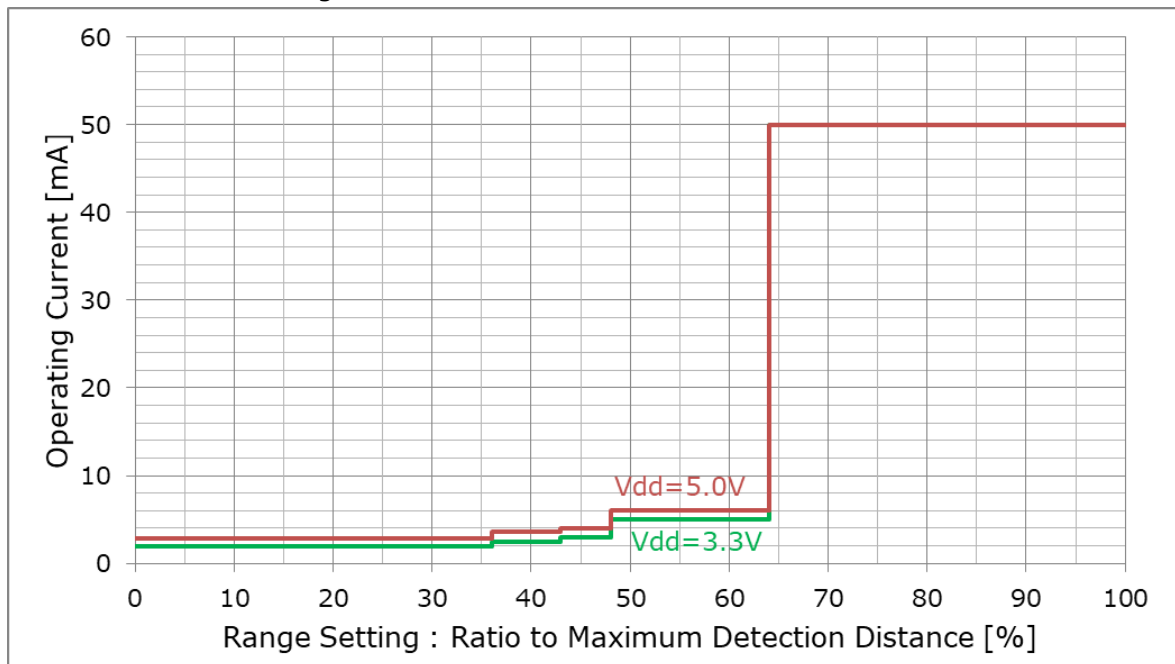
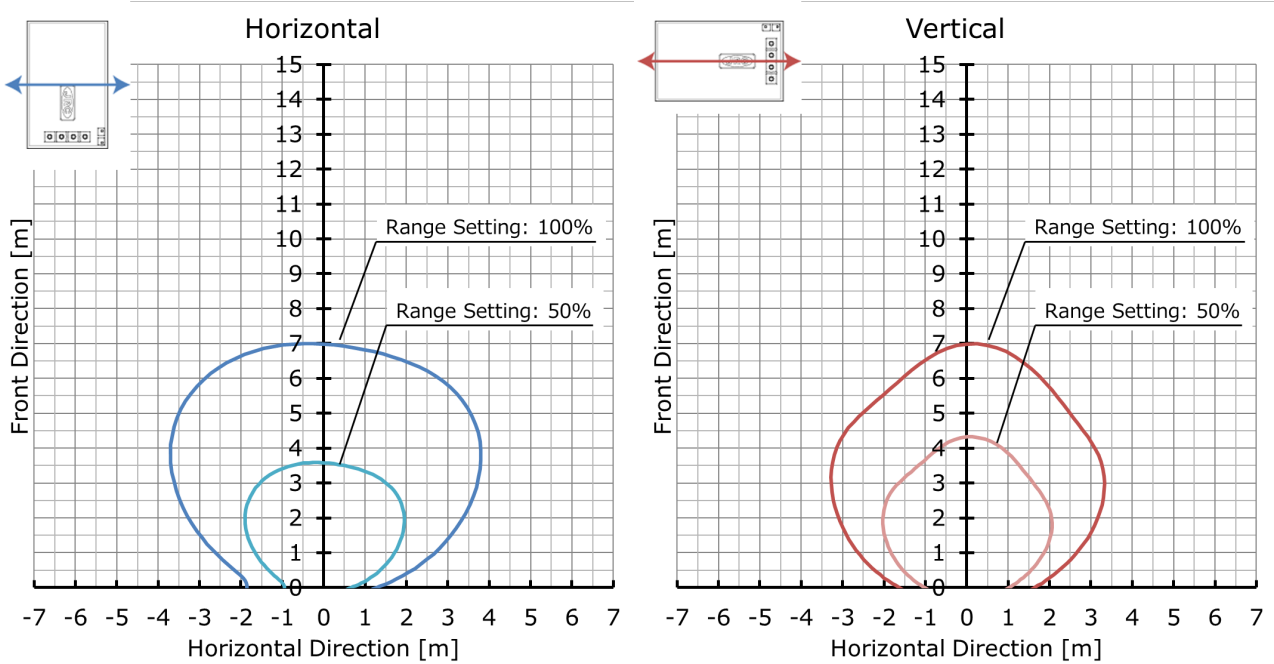

Fig. 4 Operating current relative to analog range setting

## 3.5. Detection Area \*Calculation Result

1 x 1 antenna type



2 x 1 antenna type

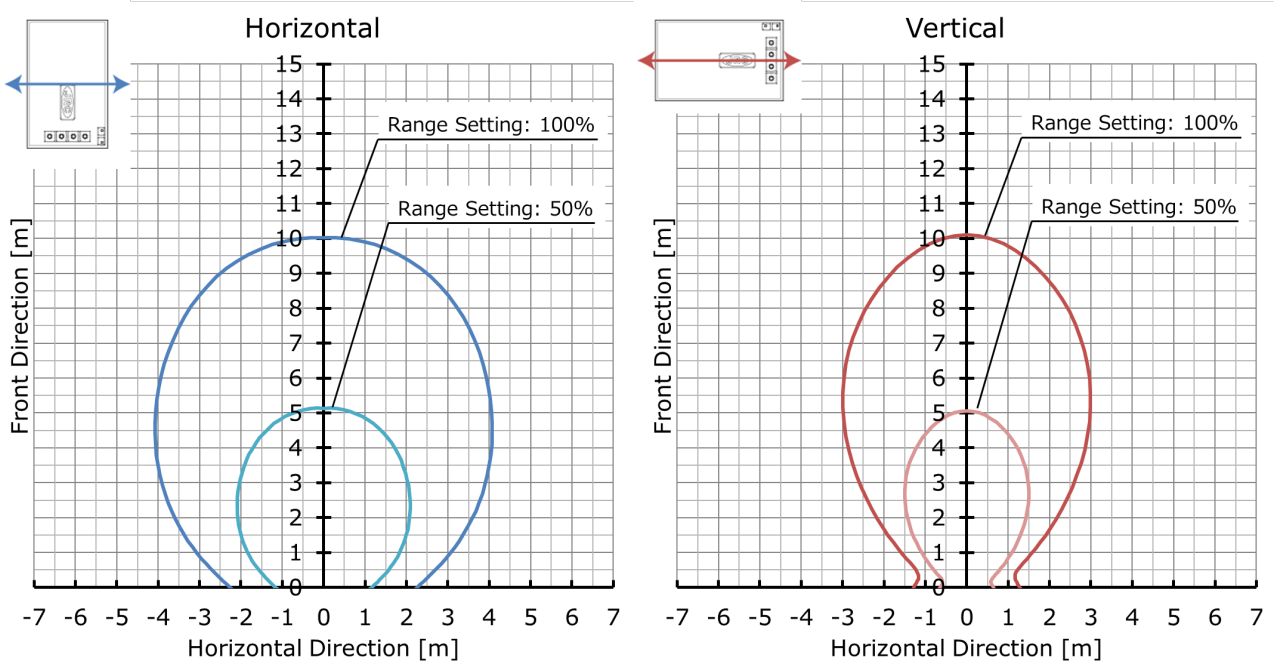

## 4 x 1 antenna type

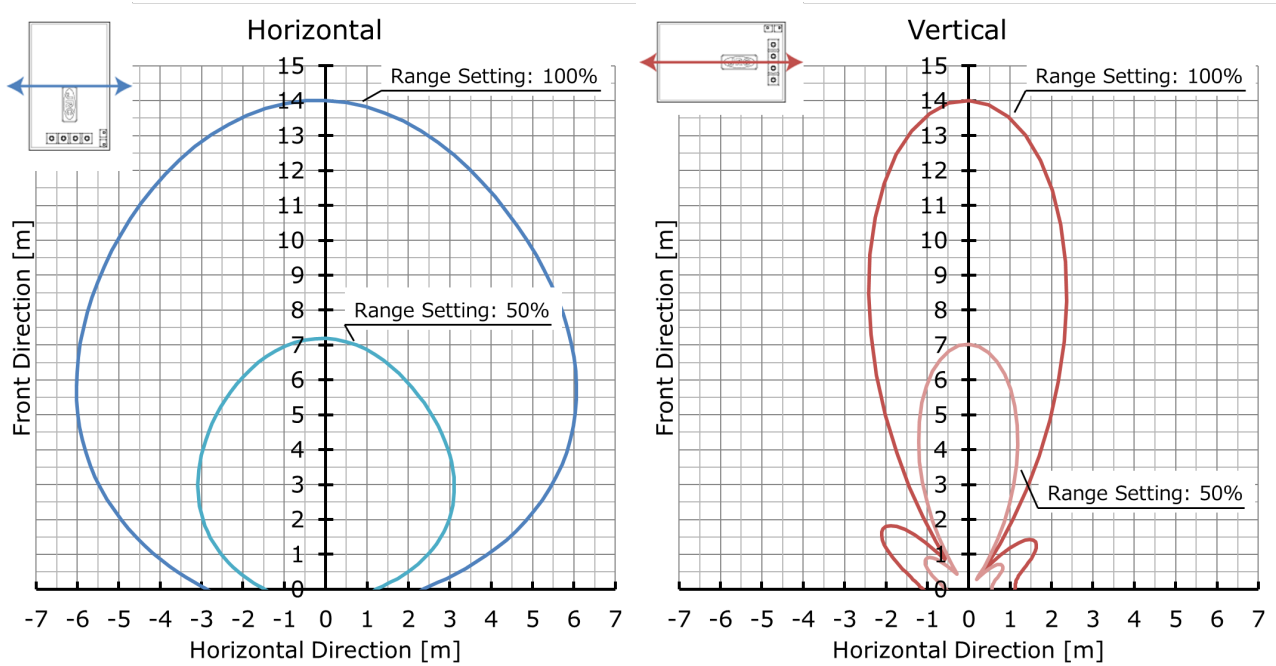

## 2 x 2 antenna type

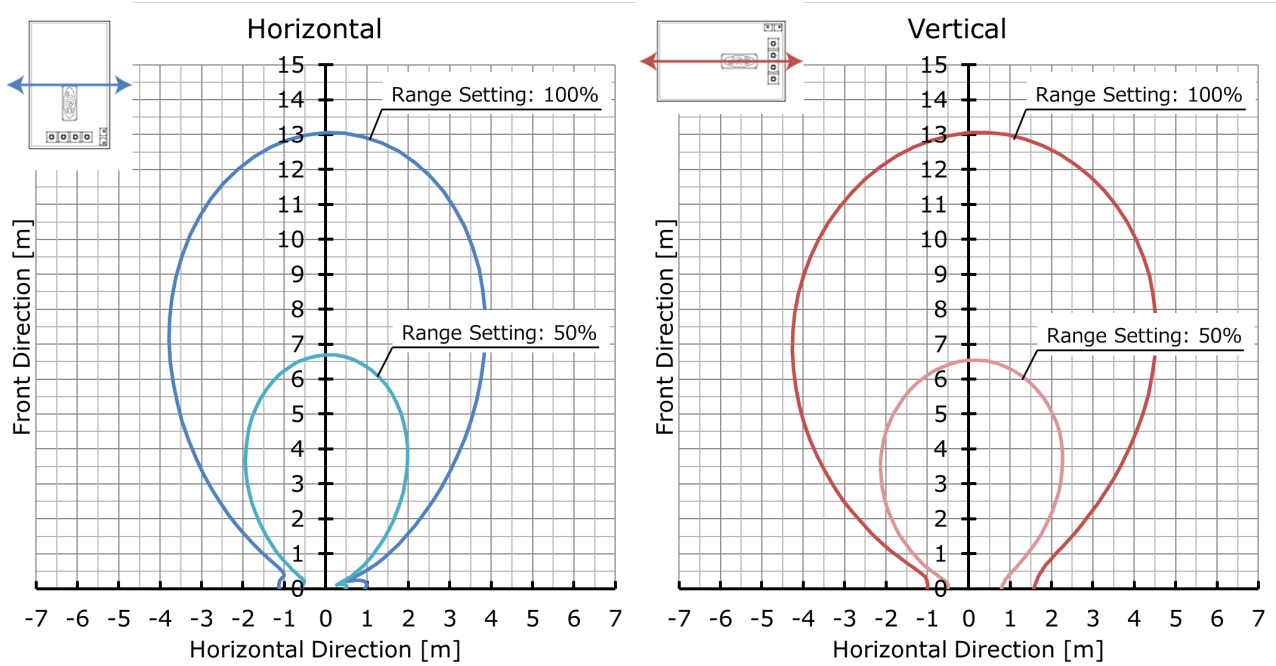

## 4. Signal Processing of Environmental Noise Reduction

This product is embedding software for the steady sensing of moving object. It is enhance the signal from movement object of pedestrian etc. and is reduce random noise and sudden signal which caused an incorrect detection by using the signal from IQ mixer, namely **Environmental Noise Reduction**.

The following effects are expectable. \*note1

- Reduction of false detection by random movement such as the shakes of plant by wind or the noise of rain etc.
- Reduction of the false detection by sudden movement such as the insect etc. which cross just before a sensor
- Steady detection of movement objects such as pedestrian under the environment where the above-mentioned noise exists.
- Reduction of the mutual interference of sensors
- Identification of direction of movement (approach and leaving)

\*Note1) This signal processing function assumes the following noises are reduced, and pedestrian's movement is emphasized. However, it is likely to become a counter productivity for a signal outside assumption.



## 5. Interface

### 5.1. Type of UART

#### 5.1.1. Pin Assignment

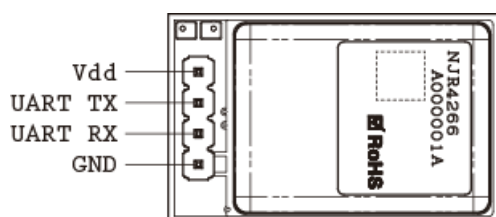

**Pin diagram (Bottom View)**

#	NAME	I/O	DESCRIPTION
1	Vdd	I	Power Supply: 3.0 to 5.25 V
2	UART TX	O	To connect UART RX of user's MCU
3	UART RX	I	To connect UART TX of user's MCU
4	GND	—	GND Pin

Refer to item 2.2 as voltage and current of UART port  
Connector: Pin-header of 2.54mm pitch

#### 5.1.2. UART Communication Interface

NJR4266 is able to control of sensor mode, set of threshold level, acquisition of detection result and acquisition of various information of sensor states from PC or MCU, etc. by using UART Interface.

ITEM	FORMAT	UNITS	REMARKS
Signal Level	CMOS	—	Equivalent to Vdd Voltage
Communication Parameters			
Baud Rates	115200	bps	
Data Bits	8	bits	
Stop Bits	1	bits	
Parity	odd	—	
Handshake	no	—	
Bit Order	LSB	—	

### 5.2. Type of Digital Output / Analog Range Setting

#### 5.2.1. Pin Assignment

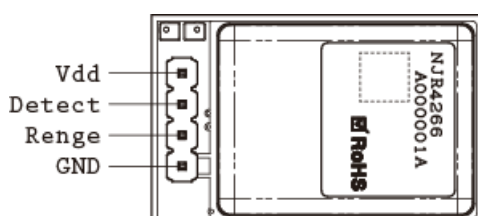

**Pin diagram (Bottom View)**

#	NAME	I/O	DESCRIPTION
1	Vdd	I	Power Supply: 3.0 to 5.25 V
2	Detect	O	Digital output of CMOS level for either approaching and leaving detection Output is changed to H level when the movements of approaching or leaving is detected. H: Detect / L: No detect Output current < 14 mA max.
3	Range	I	Analog range setting Refer to Item 4.3.
4	GND	—	GND Pin

Refer to item 2.2 as voltage and current of Detect/Range port  
Connector: Pin-header of 2.54mm pitch

## 6. Operational mode

### 6.1. Type of UART

MODE	DESCRIPTION
Power ON / Reset *note1	CPU Reset.
Initialization Mode	Initialize and wait until sensor is stabilized. (approx. 1 second )
Detection Mode	Detection command is sent when following changes arise in the state of the sensor detection. 1. Detect approaching object 2. Detect leaving object 3. State change from detection to no-detection Please perform the range setting of approaching / leaving and voltage of power supply by UART command. There are four modes in this mode: • Automatic Intermittent Setting Mode • Selectable Intermittent Setting Mode • CW Mode • Intermittent Mode
ECO Automatic Intermittent Setting Mode *note2	The appropriate intermittent operation condition is automatically set according to the range setting.
ECO Selectable Intermittent Setting Mode *note2	User can set range setting, intermittent operation condition and sensitivity time independently by command. The false detection would occur depending on above setting.
CW Mode	Continuously operate the sensor RF part.
ECO Intermittent Mode	Intermittently operate the sensor RF part to reduce the operating current.
Sleep Mode	Shutdown of all analog circuit for reducing the operating current. When returning to detection mode, approx. one second needs for stabilization of the sensor.

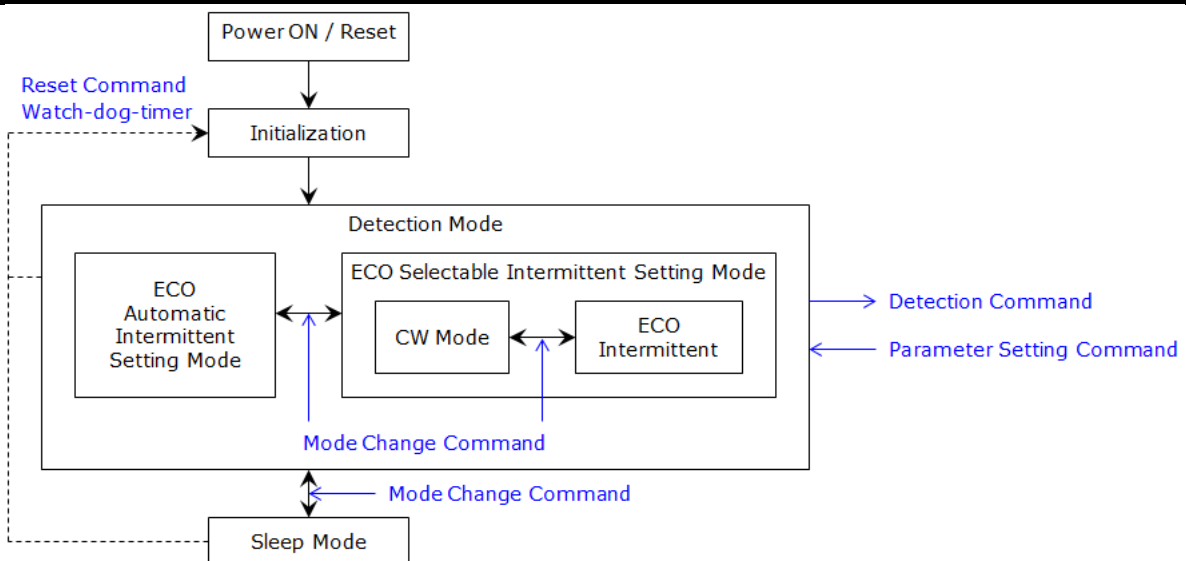

Fig.5 State Transition Diagram (Type of UART)

\*Note1) When the watch dog timer overflows, it is reset from any mode.

\*Note2) The operating current of the sensor is reduced by intermittent operation. The detection distance might decrease depending on intermittent operation conditions.

- After turning the power on and resetting, please set the following items. It can be set even in the initialization mode.
  - 1) Set the range setting and power supply voltage  
(Default: Range 30 / Power Supply Voltage 66)
  - 2) Set the detection mode form ECO automatic and selectable intermittent setting mode  
(Default: ECO Automatic Intermittent Setting Mode)
  - 3) Set the range setting, intermittent operation condition and sensitivity speed, When ECO Selectable Intermittent Setting Mode

## 6.2. Type of Digital Output / Analog Range Setting

MODE	DESCRIPTION
Power ON / Reset *note1	CPU Reset.
Initialization Mode	Initialize and wait until sensor is stabilized. (approx. 1 second )
Detection Mode	Based on the analog range setting, when the following changes occur, the voltage of the digital detect output is controlled. 1. Detect approaching object (Voltage: H) 2. Detect leaving object (Voltage: H) 3. State change from detection to no-detection (Voltage: L) The analog voltage of range setting is monitored in initialization mode and about every 1 second.

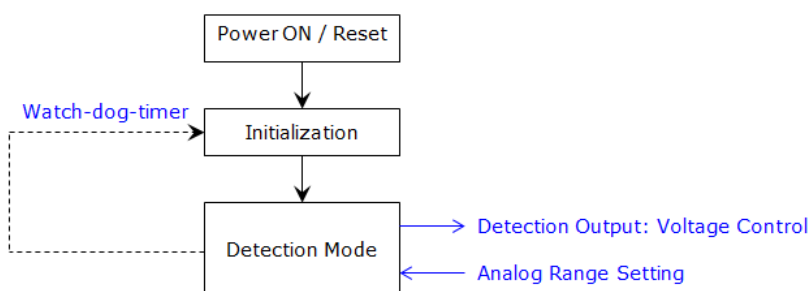

Fig.6 State Transition Diagram (Type of Digital Output / Analog Range Setting)

\*Note1) When the watch dog timer overflows, it is reset from any mode.

## 7. Communication command (for only type of UART)

### 7.1. Communication Command List

Both Sensor-to-Host (S-to-H) and Host-to-Sensor (H-to-S) are a 2-byte (fixed length) binary code. The MSB of the 1<sup>st</sup> byte is always bit set.

ITEM	Host-to-Sensor		Sensor-to-Host		DESCRIPTIONS
	1 <sup>st</sup> BYTE	2 <sup>nd</sup> BYTE	1 <sup>st</sup> BYTE	2 <sup>nd</sup> BYTE	
<b>Detection Status Notice &amp; Command</b>					
Approaching Detection	NA		1000 0000 (0x80)	0000 0001 (0x01)	Sent when state changes
Leaving Detection	NA		1000 0000 (0x80)	0000 0010 (0x02)	
No-detection	NA		1000 0000 (0x80)	0000 0000 (0x00)	
Inquiry	1000 0000 (0x80)	0000 0000 (0x00)	1000 0000 (0x80)	0000 0001 (0x01)	Approaching Detection
			1000 0000 (0x80)	0000 0010 (0x02)	Leaving Detection
			1000 0000 (0x80)	0000 0000 (0x00)	No-detection
<b>Mode Change Command</b>					
Detection Mode	1000 0001 (0x81)	0000 0000 (0x00)	NA		Default
Sleep Mode	1000 0001 (0x81)	0000 0001 (0x01)	NA		
ECO Automatic Intermittent Setting Mode	1000 0001 (0x81)	0000 0100 (0x04)	NA		Default
ECO Selectable Intermittent Setting Mode	1000 0001 (0x81)	0000 0101 (0x05)	NA		
CW Mode	1000 0001 (0x81)	0000 0010 (0x02)	NA		
ECO Intermittent Mode	1000 0001 (0x81)	0000 0011 (0x03)	NA		Default
<b>Mode Inquiry Command</b>					
Detection / Sleep Mode	1000 0001 (0x81)	0001 0000 (0x10)	1000 0001 (0x81)	0000 0000 (0x00)	Detection Mode
			1000 0001 (0x81)	0000 0001 (0x01)	Sleep Mode
ECO Automatic / Selectable Intermittent Setting Mode	1000 0001 (0x81)	0001 0010 (0x12)	1000 0001 (0x81)	0000 0100 (0x04)	ECO Automatic Intermittent Setting Mode
			1000 0001 (0x81)	0000 0101 (0x05)	ECO Selectable Intermittent Setting Mode
CW / ECO Intermittent Mode	1000 0001 (0x81)	0001 0001 (0x11)	1000 0001 (0x81)	0000 0010 (0x02)	CW Mode
			1000 0001 (0x81)	0000 0011 (0x03)	ECO Intermittent Mode

ITEM	Host-to-Sensor		Sensor-to-Host		DESCRIPTIONS
	1 <sup>st</sup> BYTE	2 <sup>nd</sup> BYTE	1 <sup>st</sup> BYTE	2 <sup>nd</sup> BYTE	
<b>Range Setting &amp; Inquiry Command</b>					
Setting Approaching Range	1000 0010 (0x82)	0XXX XXXX (0xXX)	NA		XX: 0 to 100 Correspond to ratio of maximum detection distance (%) *note1 Default: 30
Inquiry Approaching Range	1000 0011 (0x83)	0000 0000 (0x00)	1000 0011 (0x83)	0XXX XXXX (0xXX)	
Setting Leaving Range	1000 0100 (0x84)	0XXX XXXX (0xXX)	NA		
Inquiry Leaving Range	1000 0101 (0x85)	0000 0000 (0x00)	1000 0101 (0x85)	0XXX XXXX (0xXX)	
<b>Power Supply Voltage Setting &amp; Inquiry Command</b>					
Setting Power Supply Voltage	1000 1010 (0x8A)	0XXX XXXX (0xXX)	NA		XX: 60 to 105 Correspond to power supply voltage between 3.0 and 5.25 V *note2 Default: 66 (Equivalent to 3.3 V)
Inquiry Power Supply Voltage	1000 1011 (0x8B)	0000 0000 (0x00)	1000 1011 (0x8B)	0XXX XXXX (0xXX)	
<b>Sensitivity Time Setting &amp; Inquiry Command (for only Selectable Intermittent Setting Mode)</b>					
Setting Approaching Sensitivity Time	1000 0110 (0x86)	00XX XXXX (0xXX)	NA		XX: 1 to 32 Correspond to sensitivity time between 128 and 4,096 ms. *note3 Default: 1
Inquiry Approaching Sensitivity Time	1000 0111 (0x87)	0000 0000 (0x00)	1000 0111 (0x87)	00XX XXXX (0xXX)	
Setting Leaving Sensitivity Time	1000 1000 (0x88)	00XX XXXX (0xXX)	NA		
Inquiry Leaving Sensitivity Time	1000 1001 (0x89)	0000 0000 (0x00)	1000 1001 (0x89)	00XX XXXX (0xXX)	
<b>Intermittent Operation Condition Setting &amp; Inquiry Command (for only ECO Selectable Intermittent Setting Mode)</b>					
Setting Intermittent Operation Condition	1000 1100 (0x8C)	0000 0XXX (0x0X)	NA		X: 1/2/3/7 Correspond to intermittent operation condition *note4 Default depends on condition when changing Selectable Intermittent Setting Mode
Inquiry Intermittent Operation Condition	1000 1101 (0x8D)	0000 0000 (0x00)	1000 1101 (0x8D)	0000 0XXX (0x0X)	
<b>Reset &amp; Error Command</b>					
Reset	1111 1111 (0xFF)	0000 0000 (0x00)	NA		Equivalent to Power ON
UART Error	NA		1111 1111 (0xFF)	0000 ABCD (0xXX)	A bit is set when the following error. A: Syntax error B: Framing error C: Parity error D: Overrun error

\*Note1) The ratio of maximum detection distance assumes the case that an adult of 170 cm / 70 kg approaches at the rate of 0.5 m/s from the front.

\*Note2) Please set power supply voltage by command when using at power supply voltage other than 3.3 V.

\*Note3) The sensitivity time is the setting value of the time during which the signal level of the continuously exceeded the range setting by internal signal processing.

\*Note4) The intermittent operation condition is in below.

- 1: Intermittent operation of 1 kHz: 1 ms cycle, 11 us ON
- 2: Intermittent operation of 2 kHz: 500 us cycle, 11 us ON
- 3: Intermittent operation of 3 kHz: 333 us cycle, 11 us ON
- 7: Intermittent operation of 7 kHz: 147 us cycle, 11 us ON

## 8. Drawing

### 8.1. Outline

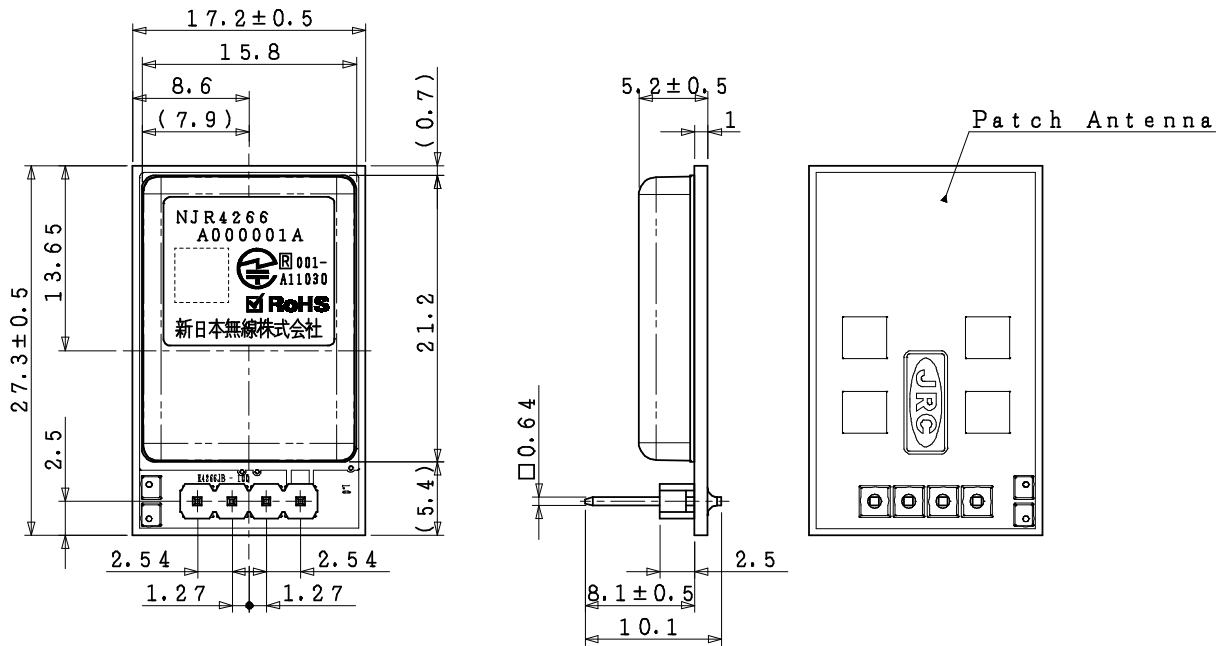

- Type of UART

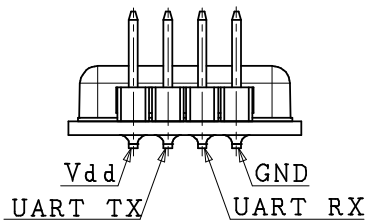

- Type of Digital Output / Analog Range Setting

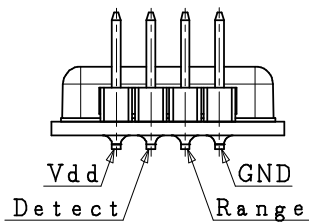

Unit: mm

Tolerance: +/-0.3

### 8.2. Label

Example)

NJR4266JB1	NJR4266F2A1	NJR4266F2B1
<p>NJR4266 JB1 A000001A</p> <p>001- A11030</p> <p>RoHS</p> <p>新日本無線株式会社</p>	<p>NJR4266F2A1 A000001A</p> <p>New Japan Radio Co., Ltd.</p>	<p>NJR4266F2B1 A000001A</p> <p>FCC ID:2ACUJR4266F2B</p> <p>New Japan Radio Co., Ltd.</p>

## 9. Environmental Characteristics

ITEM	SPECIFICATION
Operation Temperature	-20 to +60 °C
Storage Temperature	-40 to +85 °C
Humidity	0 to 95 % @+30 °C
Vibration	49.03 m/s <sup>2</sup> (5 G), 30 to 50 Hz, 10 minutes, XYZ direction
Shock	196.13 m/s <sup>2</sup> (20 G), Half sine, 11 msec, XYZ direction, 3 times



## 10. Package

### Standard Package

Packing Quantity: 500 pieces per shipping box

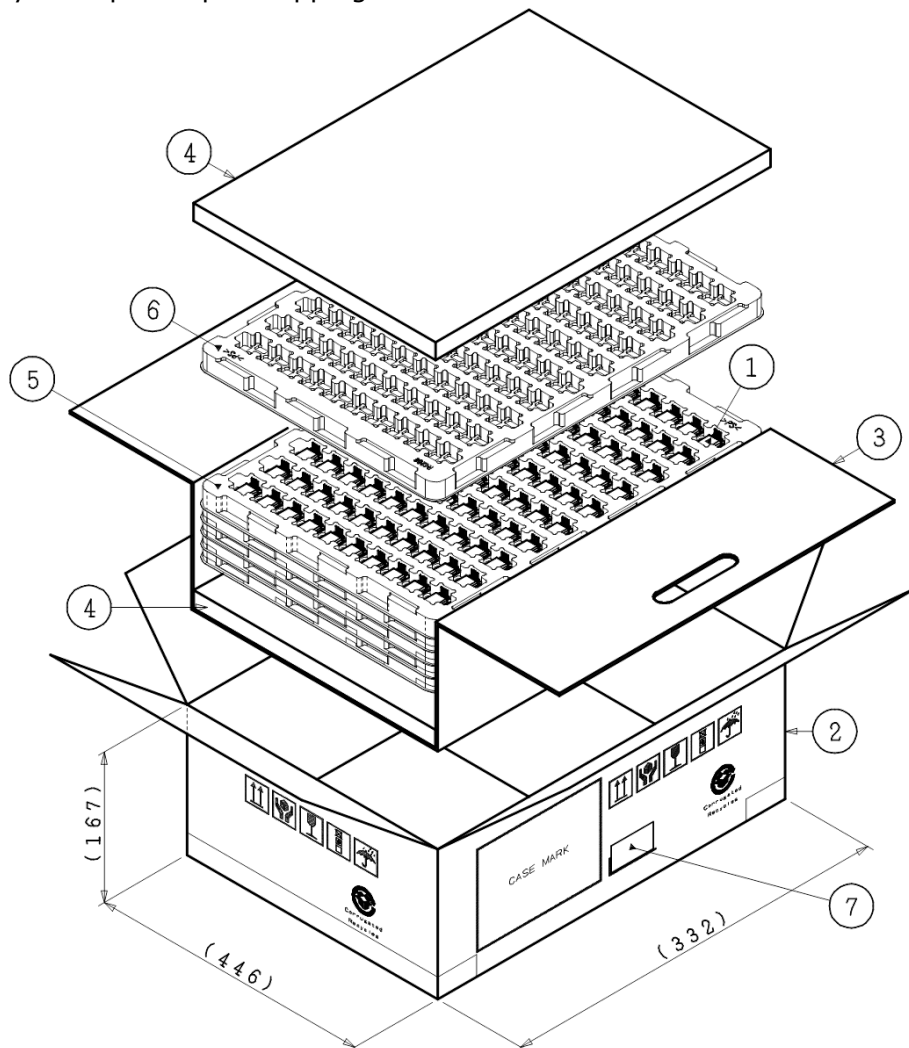

Code39 for Part number  
 Code39 for first S/N in carton  
 Code39 for end S/N in carton

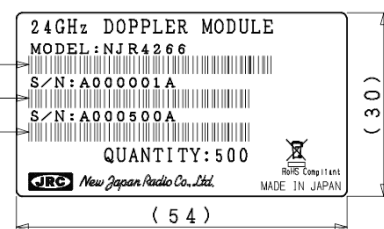

⑦: Package label

- ①NJR4266 24GHz Doppler module
- ②Outer packaging: double wall corrugated fiberboard
- ③Inner packaging: single wall corrugated fiberboard
- ④Package cushioning: polyethylene foam
- ⑤Tray for modules (100 pcs×5 trays): conductive polystyrene
- ⑥Dummy tray: conductive polystyrene
- ⑦Package label

## 11. Reference Circuit

### 11.1. Example for Type of UART

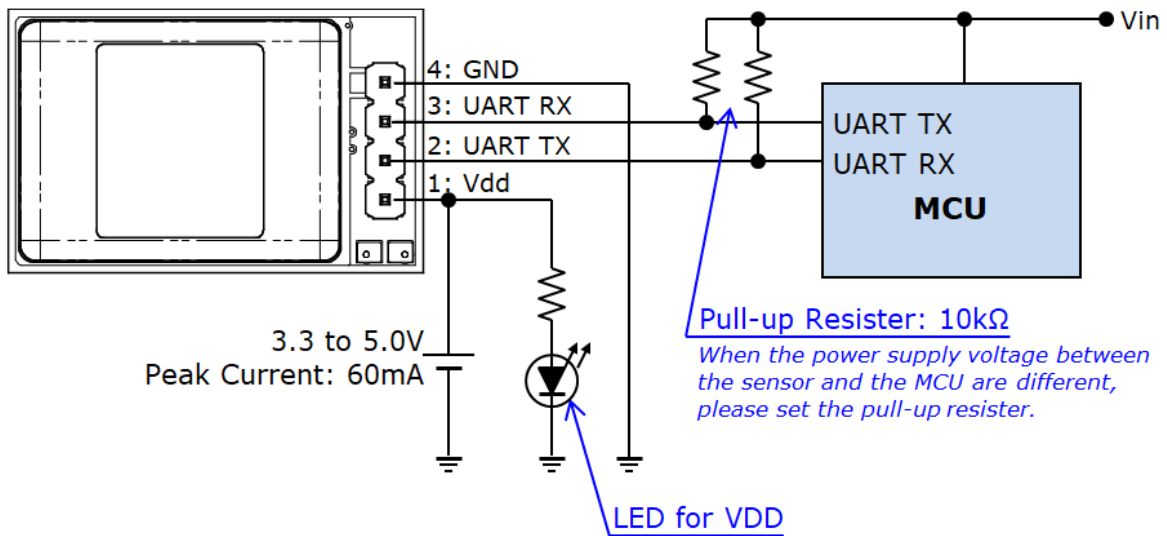

### 11.2. Example for Type of Digital Output / Analog Range Setting

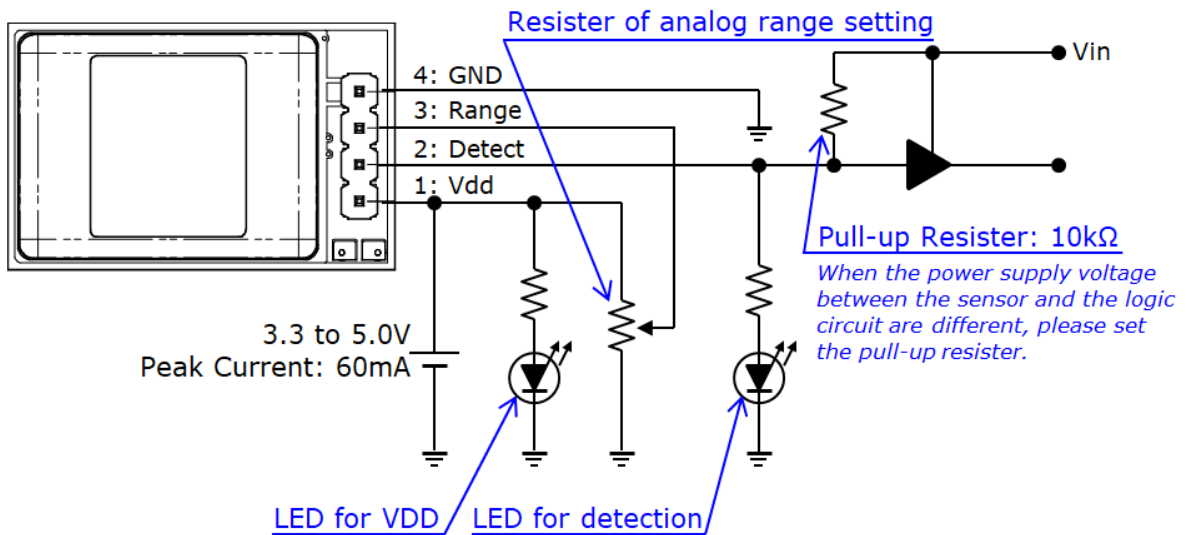

## 11.3. Recommendation Power Supply Circuit

Recommendation linear regulator: NJM2863F33 or NJM2864F33

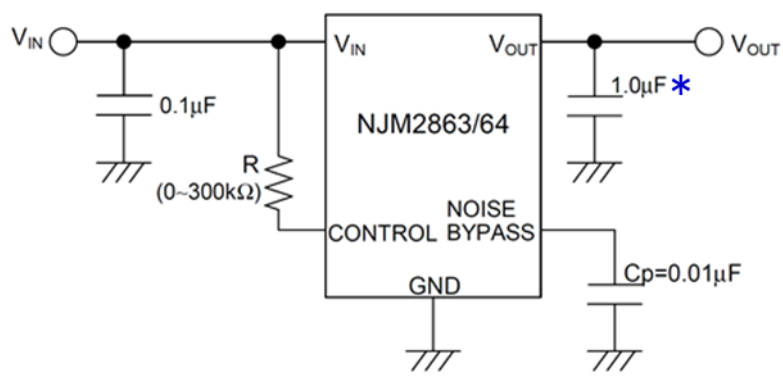

- \* To manufacture, distribute and sell unit products using this product in the EU (European Union) accession, in order to comply with Conductive Emission (EN 55022 Class B), 22 $\mu\text{F}$  and more of capacitors is connected to this product's power input terminal (Pin 1: Vdd port).

## 12. Recommendation Mounting Conditions

### 12.1. Footprint dimensions

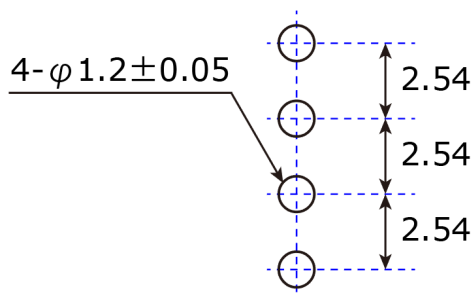

Unit: mm

\*Note) In actual design, please optimize in accordance with the situation of your board design and soldering condition.

### 12.2. Soldering conditions

- Soldering way: Solder iron \*Note
- Solder iron temperature: 350 °C or less
- Soldering time: in below

#	NAME	Soldering time
1	Vdd	3 second or less
2	UART TX / Detect	3 second or less
3	UART RX / Range	3 second or less
4	GND	6 second or less

\*Note) The soldering iron to be used must be grounded via a resistance of about 1 MΩ.



## Caution

1. NJR strives to produce reliable and high quality microwave components. NJR's microwave components are intended for specific applications and require proper maintenance and handling. To enhance the performance and service of NJR's microwave components, the devices, machinery or equipment into which they are integrated should undergo preventative maintenance and inspection at regularly scheduled intervals. Failure to properly maintain equipment and machinery incorporating these products can result in catastrophic system failures.
2. To ensure the highest levels of reliability, NJR products must always be properly handled. The introduction of external contaminants (e.g. dust, oil or cosmetics) can result in failures of microwave components.
3. NJR offers a variety of microwave components intended for particular applications. It is important that you select the proper component for your intended application. You may contact NJR's sales office or sales representatives, if you are uncertain about the products listed in the catalog and the specification sheets.
4. Special care is required in designing devices, machinery or equipment, which demand high levels of reliability. This is particularly important when designing critical components or systems whose foreseeable failure can result in situations that could adversely affect health or safety. In designing such critical devices, equipment or machinery, careful consideration should be given to, amongst other things, their safety design, fail-safe design, back-up and redundancy systems, and diffusion design.
5. The products listed in the catalog and specification sheets may not be appropriate for use in certain equipment where reliability is critical or where the products may be subjected to extreme conditions. You should consult our sales office or sales representatives before using the products in any of the following types of equipment.
  - \* Aerospace Equipment
  - \* Equipment Used in the Deep Sea
  - \* Power Generator Control Equipment (nuclear, steam, hydraulic)
  - \* Life Maintenance Medical Equipment
  - \* Fire Alarm/Intruder Detector
  - \* Vehicle Control Equipment (automobile, airplane, railroad, ship, etc.)
  - \* Various Safety Equipment
6. NJR's products have been designed and tested to function within controlled environmental conditions. Do not use products under conditions that deviate from methods or applications specified in the catalog and specification sheets. Failure to employ NJR's products in the proper applications can lead to deterioration, destruction or failure of the products. NJR shall not be responsible for any bodily injury, fires or accidents, property damage or any consequential damages resulting from the misuse or misapplication of its products. PRODUCTS ARE SOLD WITHOUT WARRANTY OF ANY OF KIND, EITHER EXPRESS OR IMPLIED, INCLUDING BUT NOT LIMITED TO ANY IMPLIED WARRANTY OF MERCHANTABILITY OR FITNESS FOR A PARTICULAR PURPOSE.
7. The product specifications and descriptions listed in the catalog and specification sheets are subject to change at any time, without notice.

**Responsible party:**

New Japan Radio Co.,Ltd.  
Microwave Division  
1-1, Fukuoka 2-chome Fujimino city Saitama Japan  
Tel: +81-49-278-1271, Fax: +81-49-278-1234

This device complies with Part 15 of the FCC rules. Operation is a subject to the following two conditions:

- (1) This device may not cause harmful interference.
- (2) This device must accept any interference received, including interference that may cause undesired operation.

**Caution**

DC power supply for each module should be conformed to the electrical specifications as described in this section. **A host in which a module is integrated should provide stable DC power through suitable regulator circuit to the module.**

**NOTE:**

Changes or modifications to the device not expressly approved by the party responsible for compliance could void the user's authority to operate the equipment(s).

This equipment has been tested and found to comply with the limits for a Class B digital device, pursuant to part 15 of the FCC Rules. These limits are designed to provide reasonable protection against harmful interference in a residential installation. This equipment generates, uses and can radiate radio frequency energy and, if not installed and used in accordance with the instructions, may cause harmful interference to radio communications. However, there is no guarantee that interference will not occur in a particular installation. If this equipment does cause harmful interference to radio or television reception, which can be determined by turning the equipment off and on, the user is encouraged to try to correct the interference by one or more of the following measures:

- Reorient or relocate the receiving antenna.
- Increase the separation between the equipment and receiver.
- Connect the equipment into an outlet on a circuit different from that to which the receiver is connected.
- Consult the dealer or an experienced radio/TV technician for help.

The equipment complies with radio frequency exposure limits set forth by the FCC for an uncontrolled environment.

The device must not be co-located or operating in conjunction with any other antenna or transmitter.

## Appendix)

### **WARNING:**

The FCC regulations provide that changes or modifications not expressly approved by the party responsible for compliance could void the user's authority to operate the equipment.

### **Limitation for use of the modules:**

When the module is installed in a host product, the module shall be connected directly to a PCB of the host product. It shall NOT be extended by any cable. DC power supply for each module must strictly be conformed to each electrical specification as described in the section 1 of this document.

### **Manual and Product Labeling information to the End User:**

End user manual must include all required regulatory information and/or warning as show in this manual.

OEM Integrator must indicate "**Contain FCC ID: 2ACUJR4266F2B**" at the outside of a host product such as label when the module is installed in the host product.

The following statement from FCC §15.19(a)(3) is required on the label of the host equipment.

This device complies with Part 15 of the FCC Rules. Operation is subject to the following two conditions:

- (1) this device may not cause harmful interference, and
- (2) this device must accept any interference received, including interference that may cause undesired operation.

OEM Integrator may be sure that the End user manual may not contain any information about the way to install or remove the modules from the host product.

### **APPLICABLE MODEL:**

This FCC Statement is valid only for the following model number:

NJR4266F2B1

NJR4266F2B2