

MPM285 Pressure Sensor



Features

- Cost Effective, Small size
- Chip from international famous brand; Laser Trimming for temperature compensation
- Pressure range: 0bar~1bar...35bar
- Gauge, Sealed gauge and Absolute
- Constant current or Constant voltage power supply
- Isolated construction, Enable to measure various media
- $\Phi 15\text{mm}$ standard OEM pressure sensor
- Full stainless steel 316L

Application

- Industrial process control
- Level measurement
- Gas, Liquid pressure measure
- Pressure checking meter
- Pressure calibrator
- Liquid pressure system and switch
- Cooling equipment and Air conditioner
- Aviation and Navigation inspection

Introduction

MPM285 pressure sensor is an cost effective piezoresistive pressure sensor with small size. It has same outline, mounting dimensions and sealing methods as our other similar products, so it is highly interchangeable. It is widely used for pressure measurement of media which is compatible with stainless steel and FKM, especially the working site with limit installation space.

Electrical Performance

- Power supply: $\leq 2.0\text{mA DC}$
- Electrical connection: $\Phi 0.5\text{mm}$ Kovar pin or 100mm silicon rubber flexible wires
- Common mode voltage output: 50% of input (typ.)
- Input impedance: $2.5\text{k}\Omega\sim 5\text{k}\Omega$
- Output impedance: $3.5\text{k}\Omega\sim 6\text{k}\Omega$
- Response (10%~90%): $< 1\text{ms}$
- Insulation resistor: $100\text{M}\Omega@100\text{V DC}$
- Overpressure: 2 times FS

Construction Performance

- Diaphragm: Stainless steel 316L
- Housing: Stainless steel 316L
- Pin: Kovar
- O-ring: FKM
- Net weight: $\sim 10\text{g}$

Environment Condition

- Shock: No change at 10gRMS, (20~2000)Hz
- Impact: 100g, 11ms
- Media compatibility: The gas or liquid which is compatible with construction material and FKM

Basic Condition

- Media temperature: (35±1)°C
- Environment temperature: (35±1)°C
- Shock: 0.1g (1m/s²) Max
- Humidity: (50±10) %RH
- Local air pressure: (0.86~1.06)bar
- Power supply: (1.5±0.0015) mA DC

Specification

Item*	Min.	Typ.	Max.	Units
Linearity		±0.15	±0.25	%FS,BFSL
Repeatability		±0.05	±0.075	%FS
Hysteresis		±0.05	±0.075	%FS
Zero output**			±2.0	mV DC
Output/Span***	50			mV DC
Zero thermal error		±0.75	±1.0	%FS, @35°C
Span thermal error		±0.75	±1.0	%FS, @35°C
Compensated temp. range		0 ~ 70		°C
Working temp. range		-40 ~ 125		°C
Storage temp. range		-40 ~ 125		°C
Stability error		±0.2		%FS/Year

* testing at basic condition
 ** Zero output for closed loop sensor
 *** Output/Span=full scale output - zero point

Outline Construction (Unit: mm)

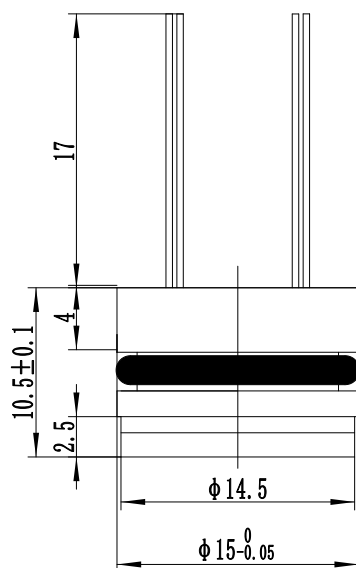

The suggested mounting dimension is $\phi 15^{+0.05}_{+0.02}$ mm

Electrical Connection

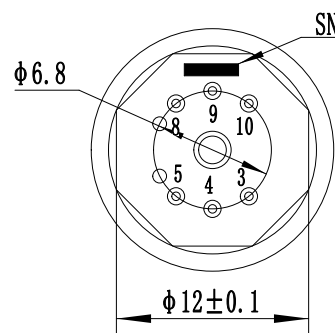

Pin	Definition
4	-OUT
5	-IN
8	+IN
9	+OUT

The actual electrical connection method, please check the parameter label enclosed with products.

Order Guide

MPM285		Pressure Sensor					
		Range code	Pressure range	Ref.	Range code	Pressure range	Ref.
		03	0bar~1bar	G.A	10	0bar~10bar	G.A
		07	0bar~2bar	G.A	12	0bar~20bar	G.A
		08	0bar~3.5bar	G.A	13	0bar~35bar	G.S.A
		09	0bar~7bar	G.A			
		Code	Pressure type				
		G	Gauge				
		A	Absolute				
		S	Sealed gauge				
		Code	Pressure connection				
		0 or null	O-ring				
		Code	Compensation				
		L	Laser trimming				
		Code	Electrical connection				
		1	Kovar pin				
		2*	100mm silicon rubber flexible wires				
MPM285	08	G	0	L	1	the whole spec	
<p>*The default code for electrical connection is "1" on the parameter card. And it is also allowed to print code "1" if the electrical connection is flexible wire (original code "2"). The wire length shall be as per customers' request on the contact.</p>							

Notes

1. The default unit of the company's products is kPa, 1kPa=0.01bar.
2. We suggest you to use Suspended construction when you install the sensor to prevent affecting sensor stability.
3. Please pay attention to protect sensor isolated diaphragm and ceramic compensated board, to avoid damaging sensor or affecting the performance.
4. Temperature resistant range of standard FKM O-ring of sensor is -20 °C ~250 °C . When working temperature is lower than -20 °C or sensor is applied in critical environment, please contact us.