

Differential Pressure Transmitter for General Industries

MDM490



Applications

- Petroleum industry
- Chemical industry
- Electricity industry
- Hydrology

Features

- Intrinsic safety product, Ex ia IIC T6 Ga
- Laser welding, full-sealed structure
- Temperature compensation and aging, stable and reliable performance
- Zero and span adjustable outside
- CE, RoHS and CCS approved

Introduction

MDM490 uses piezoresistive sensor as the sensing element, silicon oil is filled between the die and two diaphragms. When the measured differential pressure is added on the two diaphragms, the pressure could be transferred onto the die through silicon oil. The sensor die connects with an amplifier circuit through wires, uses the semiconductor's piezoresistive effect to transform the differential pressure signal into the electric signal. Since the signal output of the Wheatstone bridge on the die has a good linear relationship with the differential pressure, the differential pressure can be accurately measured.

Specifications

Range	0mbar ~ 350mbar...35bar
Overpressure	positive pressure: ≤ 2 times FS negative pressure is not allowed
Maximum Static Pressure	≤ 200 bar
Pressure Type	differential pressure
Accuracy	$\pm 0.5\%$ FS
Long-term Stability	$\pm 0.5\%$ FS/year (≤ 2 bar)
	$\pm 0.2\%$ FS/year (> 2 bar)
Application Temperature	$-30^{\circ}\text{C} \sim 80^{\circ}\text{C}$ (B1 type)
	$-20^{\circ}\text{C} \sim 70^{\circ}\text{C}$ (B2 type, cable material: PE, PVC)
	$-20^{\circ}\text{C} \sim 80^{\circ}\text{C}$ (B2 type, cable material: PUR)
Storage Temperature	$-40^{\circ}\text{C} \sim 120^{\circ}\text{C}$
	$-20^{\circ}\text{C} \sim 85^{\circ}\text{C}$ (B2 type)
Vibration	10g, 30Hz ~ 2000Hz
Shock	100g, 11ms
Protection Rating	IP65
Weight	≤ 400 g

Thermal Drift

Zero Thermal Drift	$\pm 0.03\%FS/^{\circ}C$ ($\leq 1bar$)
	$\pm 0.02\%FS/^{\circ}C$ ($> 1bar$)
Span Thermal Drift	$\pm 0.03\%FS/^{\circ}C$ ($\leq 1bar$)
	$\pm 0.02\%FS/^{\circ}C$ ($> 1bar$)

Output Signals

Output Signal	Power Supply	Output Format	Load Resistance
4mA~20mA DC(E)	15V~28V DC (The intrinsic safe product is powered by a safety barrier)	2-wire	$\leq (U-15)/0.02(\Omega)$
0mA~10mA DC(Q)			
0mA~20mA DC(U)		3-wire	>100 k Ω
0V~5V DC(J)			
1V~5V DC(F)			
0V~10V DC(V)			

Outline Dimensions

unit: mm

Hirschmann 4-pin Plug Connector (B1)

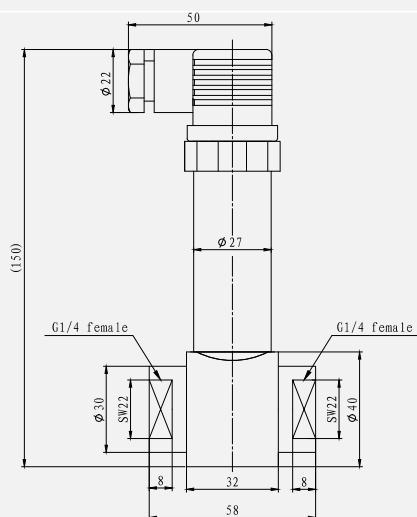

Cable Type (B2)

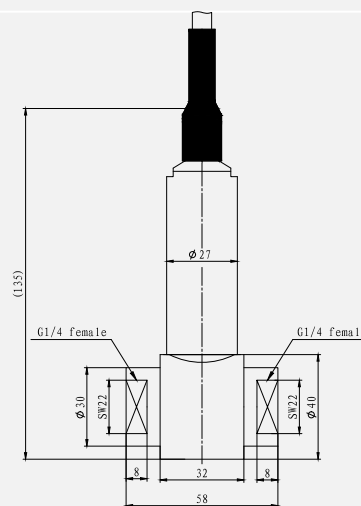

Electrical Connection

Definition	Hirschmann 4-pin Plug Connector (B1)		Cable (B2)	
	current 2-wire	voltage 3-wire	current 2-wire	voltage 3-wire
	+V	1	1	red
+OUT	2	3	black	white
GND	null	2	null	black

Materials

Wetted Parts

Isolated Diaphragm: SS 316L

Pressure Port: SS 304/SS 316L

Non-wetted Parts

Housing: SS 304/SS 316L

Cable: PE/PUR/PVC

Ordering Guide

MDM490	Differential Pressure Transmitter							
	Range	Measurement Range: 0mbar ~ 350mbar...35bar						
	[0 ~ X]mbarL or barL	X means actual measured range, L means cable length when electrical connection is B2						
	Code	Output Signal						
	E	4mA~20mA DC						
	Q	0mA~10mA DC						
	U	0mA~20mA DC						
	J	0V~5V DC						
	F	1V~5V DC						
	V	0V~10V DC						
	Code	Material						
		Isolated Diaphragm	Pressure Port					
	22	SS 316L	SS 304					
	24	SS 316L	SS 316L					
	Code	Process Connection						
	C4	G1/4 female						
	Code	Electrical Connection ^①						
	B1	4-pin plug connector						
	B2	cable connection						
	Code	Accessory						
	null	no accessory						
	M6	4 digits LED digital indicator (only for 4mA ~ 20mA DC output non-explosion proof or non-ship-use products with B1 electrical connection)						
	M7	4 digits LCD digital indicator (only for 4mA ~ 20mA DC output non-explosion proof or non-ship-use products with B1 electrical connection)						
	Code	Certification Requirement ^②						
	null	no certification requirement						
	i	intrinsic safe Exia II CT6Ga						
	T	ship-use						
MDM490	[0 ~ 16]bar	E	22	C4	B1	M6	i	Complete Type Specification

Ordering Notes

1. "①", for B1 electrical connection: no mating connector is provided by default; needs to be purchased separately.
2. "②", refers to certification requirements. For the intrinsically safety type, current output is available only. The product can be flameproof and suitable for ship-use simultaneously.
3. Cable length is 1.5m by default, Cable material is available for 3 types: PE cable is provided by default; if other material is needed, please specify in the order.
4. When ordering the transmitter with M6 or M7 indicator, power supply should $\geq 20V$ DC.
5. Environmental temperature should be $-20^{\circ}C \sim 70^{\circ}C$ when ordering the transmitter with M6 indicator, environmental temperature should be $-10^{\circ}C \sim 60^{\circ}C$ when ordering the transmitter with M7 indicator, indicator setting can refer to our indicator lectotype, which can be found on our company's website.
6. In order to ensure the safe and reliable operation of the transmitter, it is recommended to install a three-valve group between the measured point and the transmitter to ensure that the medium under test is slowly and evenly added to the difference positive and negative pressure chambers for pressure transmitters.
7. When ordering, please note that the static pressure of the measured pressure point does not exceed 200bar, and the overpressure of the positive and negative pressure chambers of the transmitter cannot exceed the specified value of the product.
8. If metrology verification certificate is needed or there are other requirements, please contact us and specify it in the order.