

MDM290 Differential Pressure Sensor



Introduction

MDM290 differential pressure sensor is OEM differential pressure sensor with stainless steel isolated diaphragm. It has integrated construction, high static pressure, high stability and good reliability. The high and low pressure sides are protected by isolated diaphragm. It can be used for measuring corrosive and conductive fluid media. The measured differential pressure is transmitted onto the die through the diaphragm and filling silicon oil so that the sensor could measure differential pressure precisely. The sensor is tested automatically, and compensated zero and temperature performance with provided resistors. The installation dimension is consistent with general products which makes the sensor has a good interchangeability. It is widely used for industrial process control and differential pressure measure fields, etc.

Features

- Pressure range: 0bar ~ 0.35bar...35bar
- Constant current or constant voltage power supply for option
- Isolated construction, Possible to various fluid media
- OEM differential pressure sensor
- Stainless steel 316L
- High static pressure 200bar
- 2 times overpressure

Application

- Industrial process control
- Differential pressure measurement
- Gas, Liquid pressure measure
- Pressure checking meter
- Pressure calibrator
- Ventura and Eddy-current flow meter

Electric Performance

- Power supply: $\leq 2.0\text{mA DC}$
- Electrical connection: 100mm silicon rubber flexible wires
- Common mode voltage input: 50% of input (typ.)
- Input impedance: $3\text{k}\Omega \sim 8\text{k}\Omega$
- Output impedance: $3.5\text{k}\Omega \sim 6\text{k}\Omega$
- Response (10% ~ 90%): $< 1\text{ms}$
- Insulation resistor: $100\text{M}\Omega @ 100\text{V DC}$
- Max. static pressure: 200bar
- Zero drift or static pressure: $\leq 0.05\text{mV/bar}$

Construction Performance

- Diaphragm: Stainless steel 316L
- Housing: Stainless steel 316L
- Pin: Silicon rubber flexible wire
- O-ring: FKM
- Net weight: $\sim 36\text{g}$

Environment Condition

- Shock: No change at 10gRMS,(20 ~ 2000)Hz
- Impact: 100g, 11ms
- Media compatibility: The gas or liquid which is compatible with stainless steel and FKM

Basic Condition

- Media temperature: (25±1)°C
- Environment temperature: (25±1)°C
- Shock: 0.1g (1m/s²) Max.
- Humidity: (50±10)%RH
- Local air pressure: (0.86~1.06)bar
- Power supply: (1.5±0.0015)mA DC

Specification

Item*	Min.	Typ.	Max.	Units
Linearity		±0.15	±0.25	%FS,BFSL
Repeatability		±0.05	±0.075	%FS
Hysteresis		±0.05	±0.075	%FS
Zero output			±3.0	mV DC
Output/Span**	60			mV DC
Zero thermal error		±0.75	±1.0	%FS, @25°C
Span thermal error		±0.75	±1.0	%FS, @25°C
Compensated temp. range		0 ~ 50		°C
Working temp. range		-40 ~ 125		°C
Storage temp. range		-40 ~ 125		°C
Long-term stability		±0.3	±0.5	%FS/Year

*testing at basic condition
**Output/Span=full scale output - zero point

Outline Construction (Unit: mm)

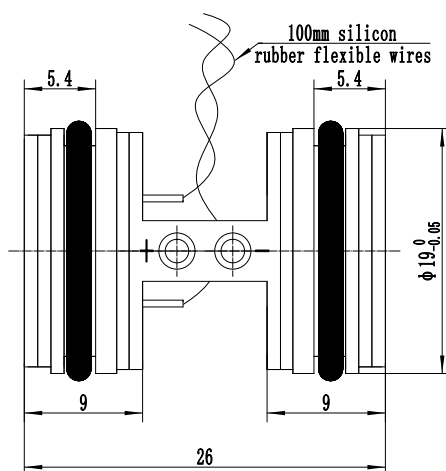

The suggested installation dimension is $\phi 19_{+0.02}^{+0.05}$ mm

Electrical Connection

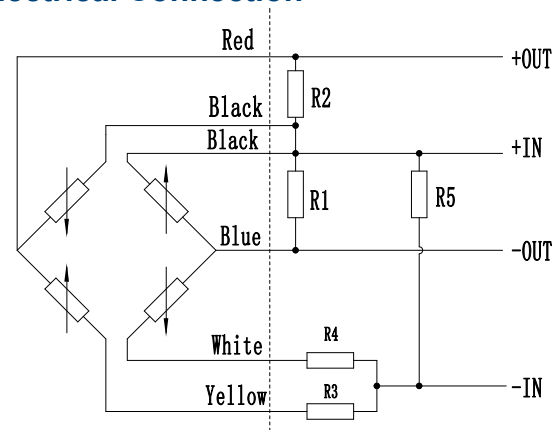

Notes

1. Compensation method M-type, range code 0A-10 for 6-wire system, 12-13 for 5-wire system.
2. The actual electrical connection method, please check the parameter label enclosed with products.

Compensation method	Definition	Wire color
L Type	+OUT	Red
	+IN	Black
	-OUT	Blue
	-IN	Yellow
M Type	+IN	Black
	+IN	Black
	-IN	Yellow
	-IN	Yellow
	+OUT	Red
	-OUT	Blue

- MDM290-M type sensor has no laser trimming board, it compensates zero drift and temperature drift by outer compensated resistors, please see the above chart for the connection. Please connect zero trimming resistor R3(R4), the other R4(R3) is short circuit as negative power supply; R1 or R2 is zero temperature drift compensated resistor, only one of them is used, the other is open circuit, please select the correct resistor value according to the specification label enclosed with sensor; R5 is sensitivity temperature compensated resistor. We suggest connecting the outer resistor and differential pressure sensor as close as possible during usage.

Order Guide

MDM290		Differential Pressure Sensor			
		Range code	Pressure range	Range code	Pressure range
		0A	0bar ~ 0.35bar	09	0bar ~ 7bar
		02	0bar ~ 0.70bar	10	0bar ~ 10bar
		03	0bar ~ 1bar	12	0bar ~ 20bar
		07	0bar ~ 2bar	13	0bar ~ 35bar
		08	0bar ~ 3.5bar		
		Code	Compensation		
		L	With compensated circuit board		
		M	Outer compensated resistor (providing resistor value)		
			Code	Electrical connection	
			2	100mm silicon rubber flexible wires	
MDM290	10	M	2	the whole spec	

Notes

- The default unit of the company's products is kPa, 1kPa=0.01bar.
- Please notice that one side of the leading wire is High Pressure Side, the other is Low Pressure Side. Or identify High Pressure Side by mark "+", and identify Low Pressure Side by mark "-" carefully.
- Please pay attention to protect the diaphragm, prevent it from damaging.
- Please do not pull or drag the 6 leading wires.
- Temperature resistant range of standard FKM O-ring of sensor is -20°C ~ 250°C . When working temperature is lower than -20°C , or sensor is applied in critical environment, please contact us.