



VCSEL Array Module (Product Specification)

Approval Sheet

PV85QB4 V9 VCSEL Array Module
Product Specification

RoHS

Product	VCSEL Array Module
Part Number	PV85QB4 V9
Customer	
Issue Date	2023/10/23

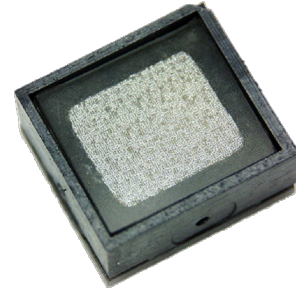

■ Features

- ✓ Compact dimensions: 3.5 mm × 3.2 mm × 1.6 mm
- ✓ Peak wavelength: $\lambda_p = 940$ nm
- ✓ Rectangular emission pattern with a 113° × 94° diffuser
- ✓ Environmental friendly ; RoHS compliance

■ Applications

- ✓ Scene understanding with multi-object detection
- ✓ 3D depth assistance
- ✓ Presence detection

Outline Dimension

PV85QB4 V9 VCSEL Array Module
 Product Specification

Package Dimension

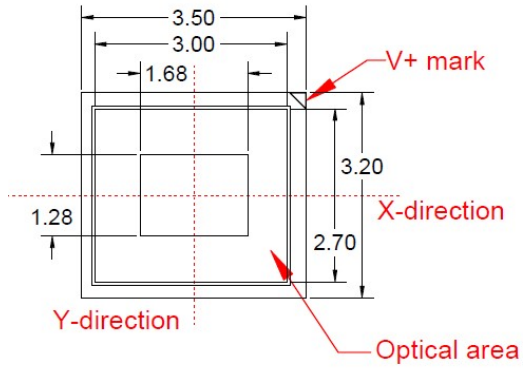

Top view

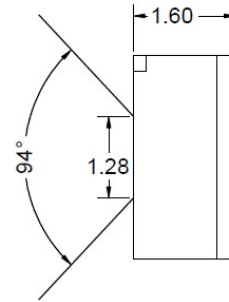

Side-Y view

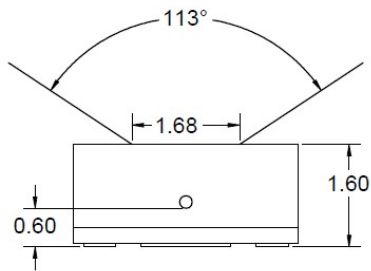

Side-X view

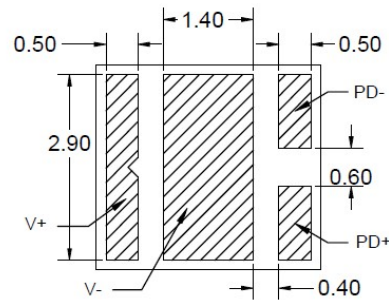

Bottom view

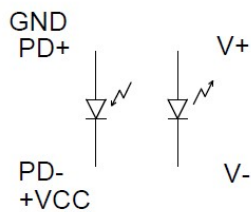

Circuit Diagram

Unit: mm
 Tolerance: ± 0.1 mm

Characteristics

PV85QB4 V9 VCSEL Array Module
 Product Specification

■ Electro-optical Characteristics ($T_a=25^\circ\text{C}$)

Parameter	Symbol	Condition	Min.	Typical	Max.	Unit
Forward Voltage	V_F	$I_F = 4.5 \text{ A}$	3.2	3.5	3.8	V
Wavelength	λ_p	$I_F = 4.5 \text{ A}$	930	940	950	nm
Wavelength temperature variation	$\Delta\lambda_p / \Delta T$	$I_F = 4.5 \text{ A}$		0.07		nm/ $^\circ\text{C}$
Radiant Power	Φ_e	$I_F = 4.5 \text{ A}$	6100	6900	7700	mW
Slope Efficiency	SE			1.8		W/A
Spectral Width(FWHM)	$\Delta\lambda$	$I_F = 4.5 \text{ A}$		2.2		nm
Threshold Current	I_{th}		0.25	0.7	1.2	A
Power Conversion Efficiency	PCE	$I_F = 4.5 \text{ A}$		44		%
x-direction Divergence Angle(FWHM)	θ_x	$I_F = 4.5 \text{ A}$		104		deg
y-direction Divergence Angle(FWHM)	θ_y	$I_F = 4.5 \text{ A}$		83		deg
FOV-x	FOV_x	$I_F = 4.5 \text{ A}$		113		deg
FOV-y	FOV_y	$I_F = 4.5 \text{ A}$		94		deg
Series resistance	R_s	$I_F = 4.5 \text{ A}$		0.19		Ohm

Note:

- (1) Lextar maintains a tolerance of $\pm 10\%$ on radiant power, $\pm 0.1\text{V}$ on forward voltage and $\pm 1\text{nm}$ on peak wavelength measurements.
- (2) All test item are measured with 0.5ms pulse current, single pulse
- (3) For divergence angle, emitted light from the package was projected on a flat screen. Divergence angle was calculated from full-width-half-maximum (FWHM) intensity distribution of the projected emission pattern.
- (4) Field of view (FOV) is distribution of radiation intensity which is measured with a goniometer system. Emitted light from package is measured by a photo-detector directly without a screen.

■ **Photo-diode Electro-Optical Characteristics**

Parameter	Symbol	Condition	Min.	Typ.	Max.	Unit
Forward Voltage	V_F	$I_F=10\text{mA}, H=0$	0.5		1.3	V
Reverse Breakdown Voltage	V_{BR}	$I_R=100\mu\text{A}, H=0$	35			V
Reverse Dark Current	I_D	$V_R=10\text{V}$		2	10	nA
Light Current	I_L	$V_R=5\text{V}$ $I_{F(VCSEL)}=4.5\text{A}$		4.5		mA
Peak Sensing Wavelength	λ_p			940		nm
Junction Capacitance	C_J	$V_R=3\text{V}, H=0$ $f=1\text{ MHz}$		2	10	pF

■ **Absolute Maximum Ratings**

Parameter	Symbol	VALUE	Unit
Operation Temperature-extended ⁽¹⁾	T_{op}	-40~105	°C
Storage Temperature	T_{stg}	-40~125	°C

Note:

(1) Extended operation temperature for <1% of operation time

■ **Forward Voltage vs. Current**

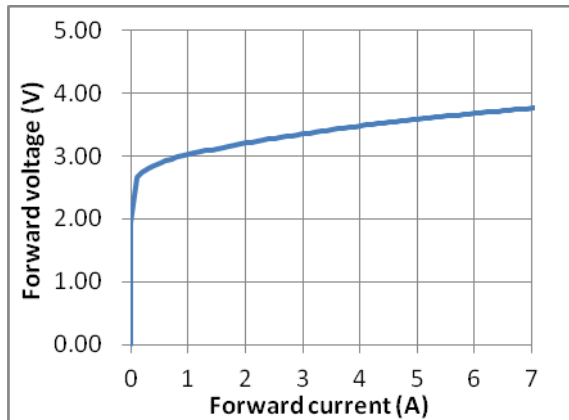

■ **Radiant Power vs. Current**

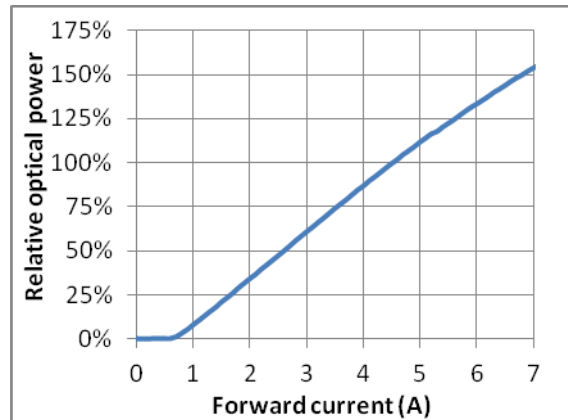

■ **Spectrum**

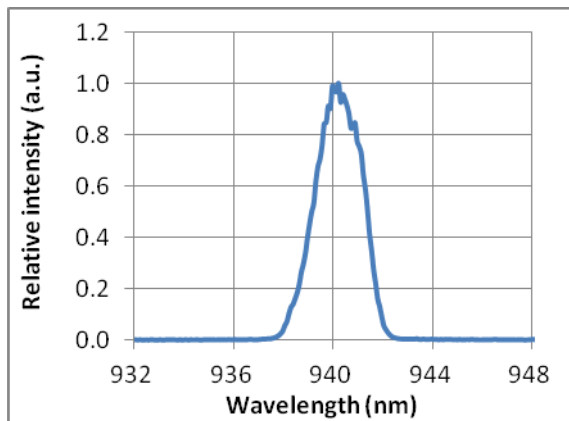

Packing

PV85QB4 V9 VCSEL Array Module
 Product Specification

Emitter Reel Packing

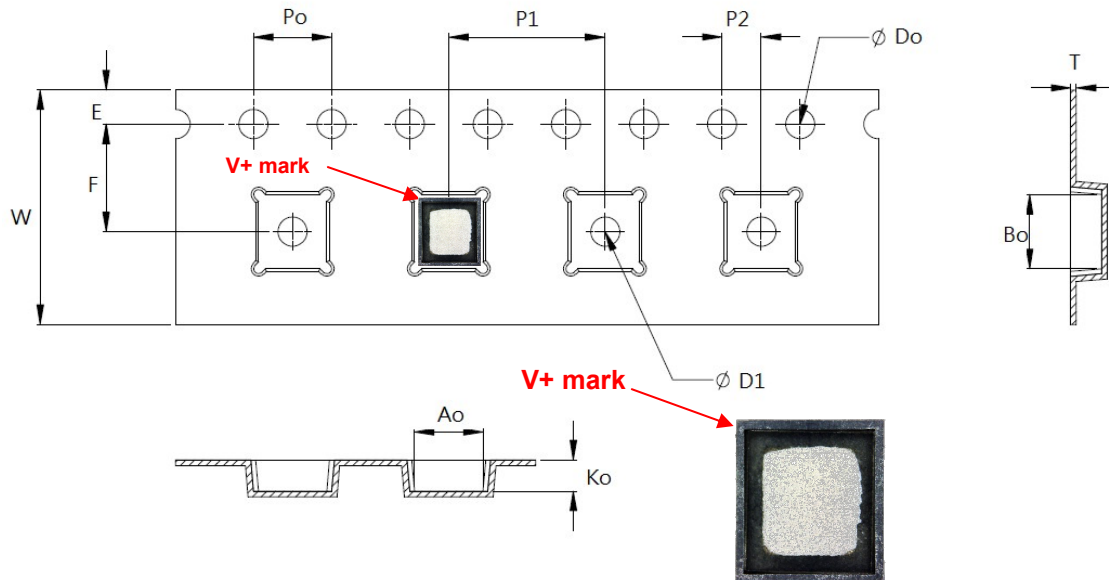

UNIT:mm

symbol	Ao	Bo	Ko	Po	P1	P2	T
spec	3.70±0.10	3.70±0.10	2.4±0.10	4.00±0.10	8.00±0.10	2.00±0.05	0.3±0.10
symbol	E	F	Do	D1	W	10Po	--
spec	1.75±0.10	5.50±0.05	1.55±0.05	1.5 min	12.0±0.30	40.0±0.20	--

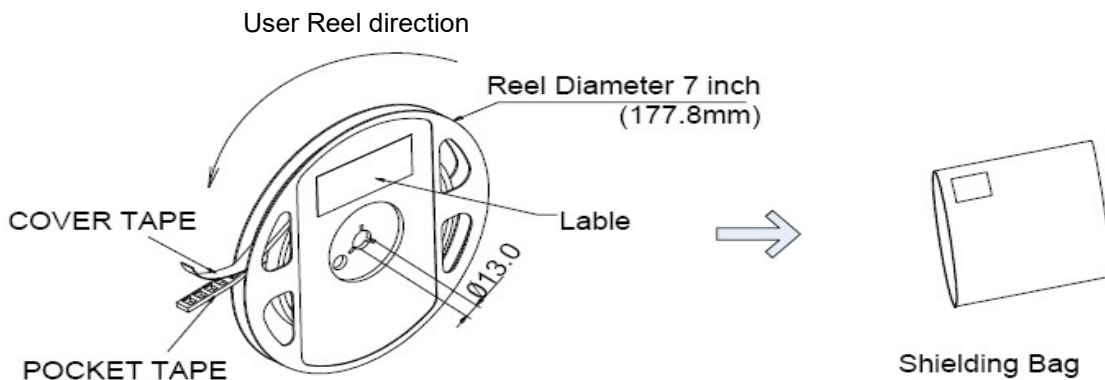

7 inch Anti-Static Reel
 Max 500pcs/reel
 Min 200pcs/reel

■ **Small Box**

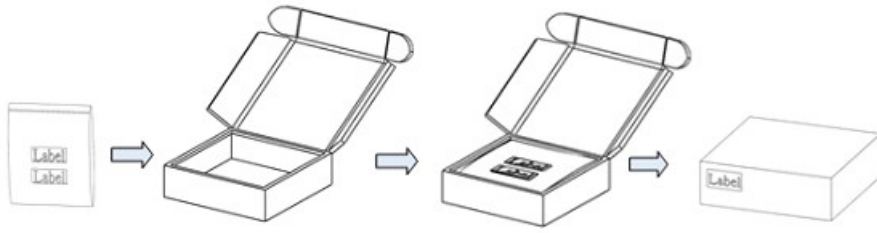

■ **Medium Box**

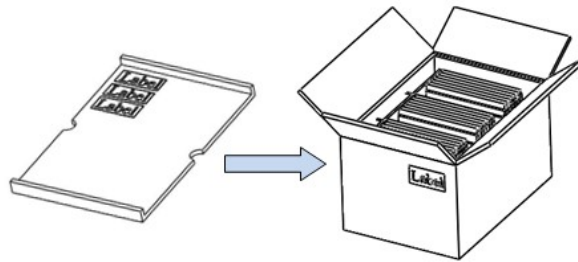
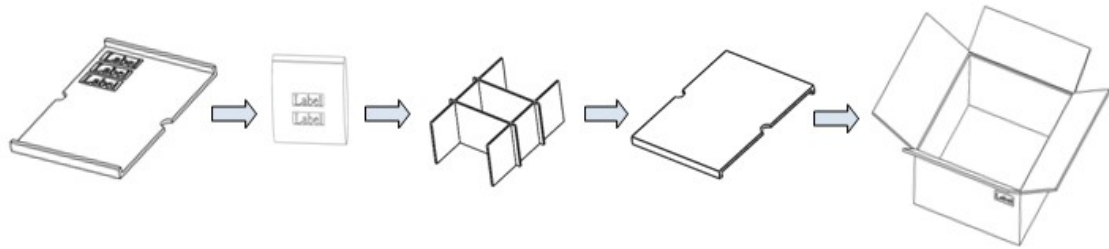

■ **Large Box**

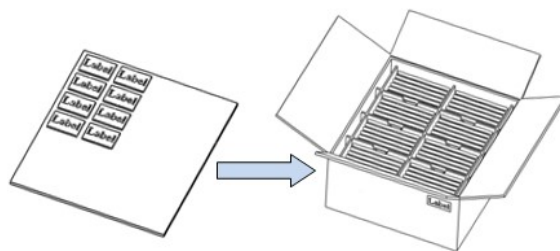
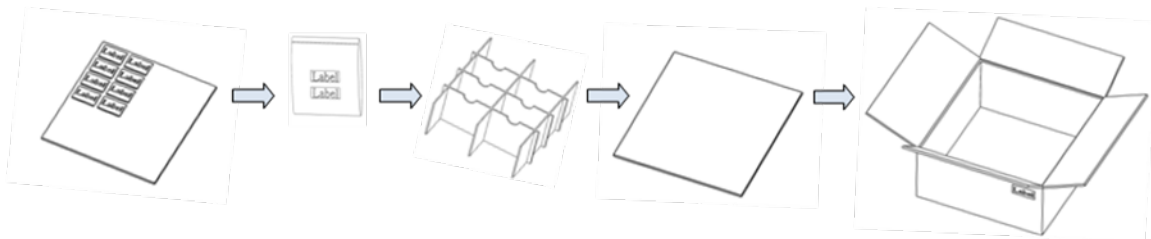

Application Notes

PV85QB4 V9 VCSEL Array Module
Product Specification

■ Recommended PCB solder pads layout

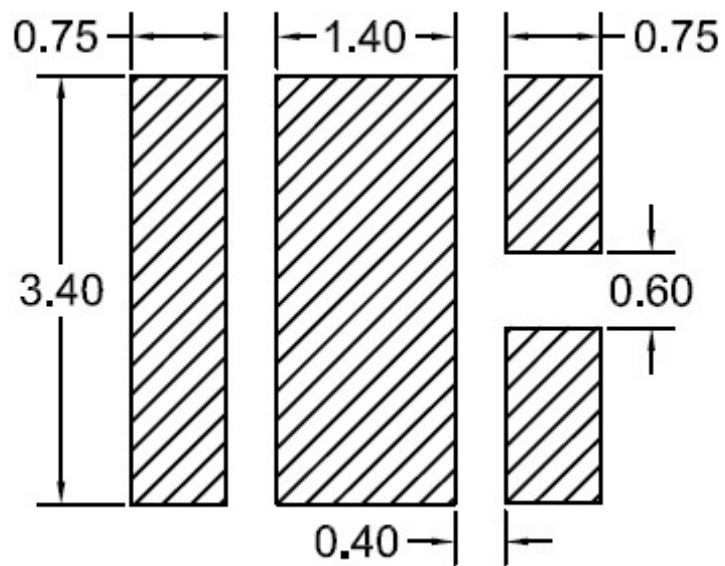

Unit: mm

Tolerance: ± 0.1 mm

Recommended Reflow Soldering Profile (JEDEC-STD-020 latest version compliant)

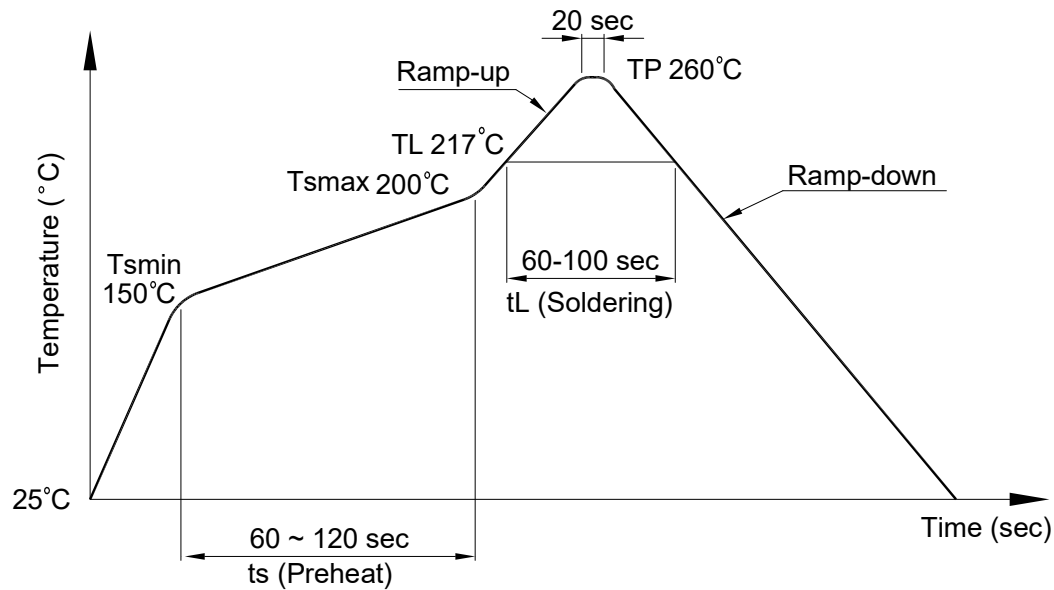

Profile Items	Conditions
Preheat	
-Temperature Min.(T_{Smin})	150°C
-Temperature Max.(T_{Smax})	200°C
-Time(Min. to Max.)(t_s)	90±30 sec
Soldering Zone	
-Temperature(T_L)	217°C
-Time	60~100 sec
Peak Temperature(T_P)	260°C
Ramp-up rate	3°C / sec max.
Ramp-down rate	3~6°C / sec

Note:

1. One time soldering is recommended; do not exceed 3 times reflow process.
2. The recommended peak temperature is 245°C. The maximum soldering temperature should be controlled under 260°C.

Handing manual

Do not touch the lens and housing with the tweezers or fingers. Do not push on the lens. Do not apply more than 1Kg of force directly onto the lens. Excessive force on the lens could damage the PKG. Please handle the component by clamping ceramic substrate.

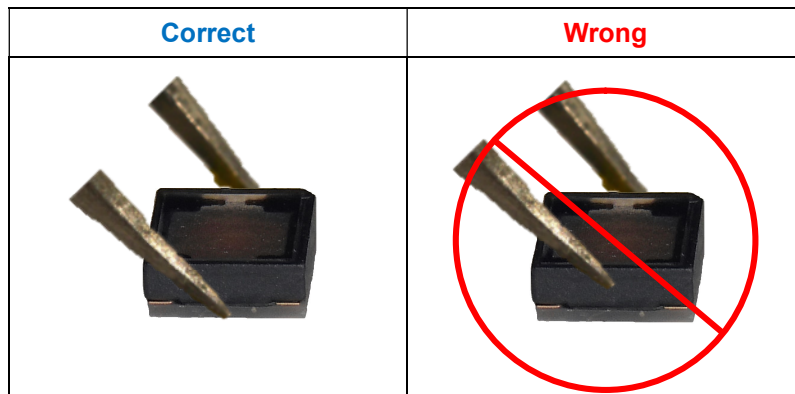

■ Storage

- Before opening the package, the Device should storage under 30°C, 70% RH. Recommend to use within one year.
- After opening the package bag, the Device should be keep under 30°C, 60% RH. Recommend to use within 7days. If unused Device remain, suggest to store into moisture proof bag or original package bag with moisture absorbent material such as silica gel. Reseal well is necessary.
- If the product exceeded the storage period or the moisture absorbent material faded away, baking treatment should be done by following conditions.
Bake condition: 60°C, 12hours (One time only).

■ Static Electricity

- Device package is extremely sensitive to static electricity. It's recommended that anti-electrostatic glove and wrist band is necessary when handling the Device. All devices are also be grounded properly as well.
- Protection devices design should be considered in the Device driving circuit

■ Cleaning

- Do not clean the device by dipping into any liquid or flushing with any liquid.
- Recommend to clean the device by air blowing, if necessary.

Revision History

PV85QB4 V9 VCSEL Array Module
Product Specification

Revision	Date	Description
A_00	04/21/2023	- Preliminary Document
A_01	06/27/2023	- update Radiant Power
A_02	08/25/2023	- update Threshold Current Max & min
A_03	09/22/2023	- update Radiant Power Max & min PD Light Current Typ.
A_04	10/23/2023	- update Threshold Current Max