

1614.2nm DFB Laser diode for CH4 Sensing

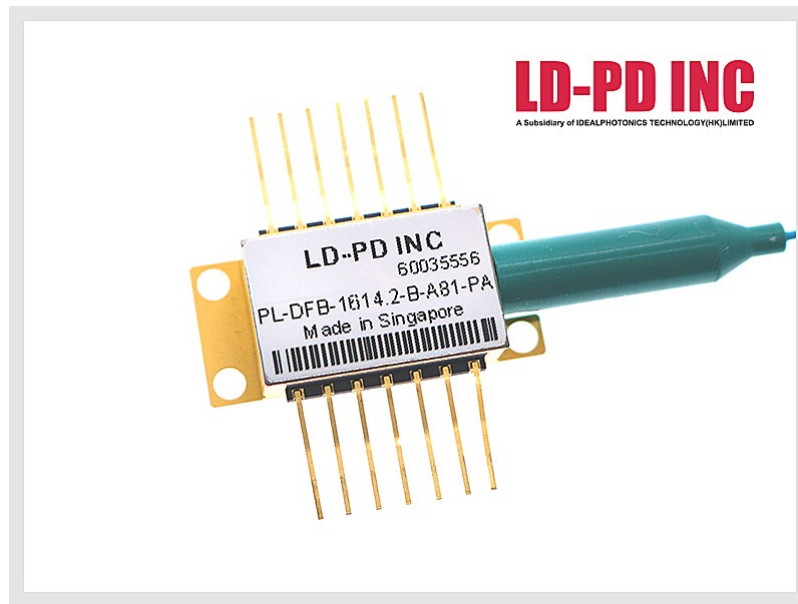

Description:

The PL-DFB-1614.2-A1 1614.2nm DFB laser diode module made by LD-PD is a cost effective, highly coherent laser source. The DFB laser diode chip is packaged in an industry standard hermetically sealed 14 pin butterfly package with TEC and PD Built in.

Features:

- Narrow Linewidth < 2MHz
- Excellent wavelength control and stability
- Industry Standard 14 pin Butterfly package
- Mode-Hop free tuning
- Excellent reliability
- Customer specific wavelengths available

Application:

- Tunable diode laser absorption spectroscopy
- CH4 Monitoring

Laser Specifications:

Tsub=25°C, CW bias unless stated otherwise

| Parameter | Symbol | Min | Typ | Max | Unit |
|--------------------------------|--------------------------|--------|--------|--------|------------|
| Centre Wavelength | λ | 1613.5 | 1614.2 | 1615.5 | nm |
| Side Mode Suppression Ratio | SMSR | 30 | 40 | | dB |
| Threshold Current | I _{th} | | 20 | 30 | mA |
| Operating Current | I _{op} | | 80 | 120 | mA |
| Chip output Power | P _f | 10 | 15 | 30 | mW |
| Quantum Efficiency | η | 0.08 | 0.12 | | mW/mA |
| Current Tuning Coefficient | $\Delta\lambda/\Delta I$ | | 0.015 | | nm/mA |
| Temperature Tuning Coefficient | $\Delta\lambda/\Delta T$ | | 0.12 | | nm/K |
| Forward Voltage | V _f | | 1.3 | 2 | V |
| Thermistor Resistance | R _T | 9.5 | 10 | 10.5 | K Ω |
| Thermistor Temp. Coefficient | | | -4.4 | | %/°C |
| Connector | FC/APC | | | | |

Spectrum:

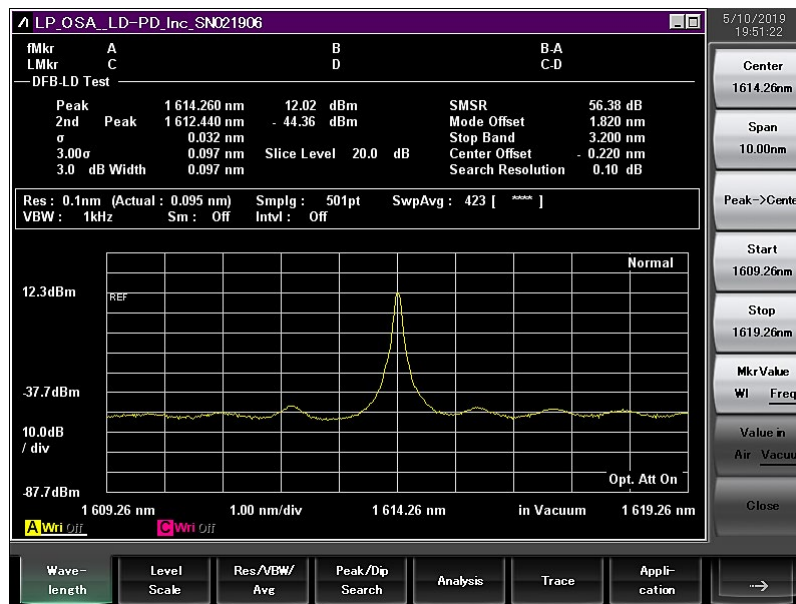

L-I Curve:

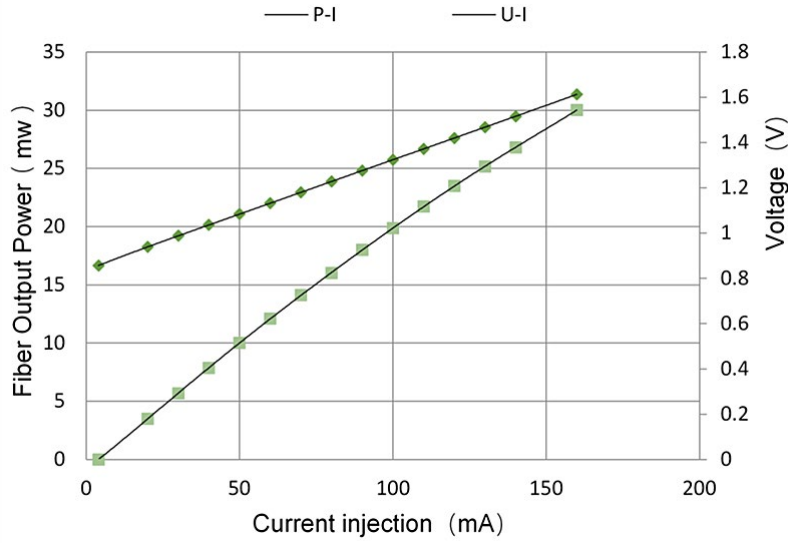

DFB Linewidth Testing Result:

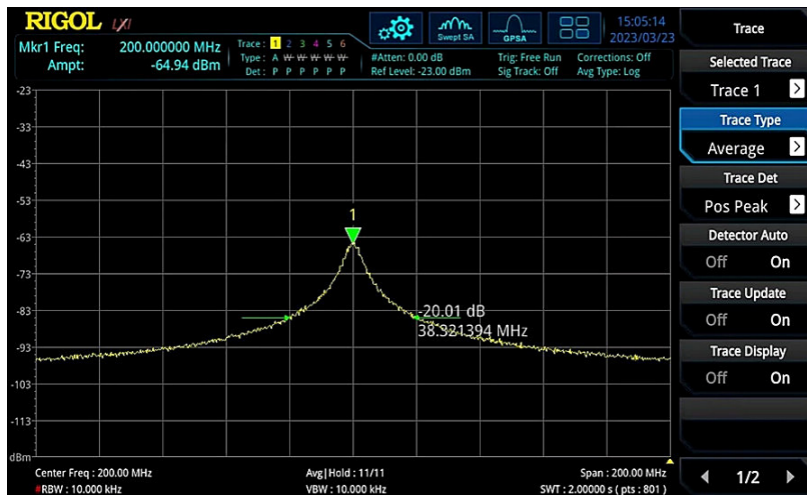

Beam Quality Profiler (2D/3D):

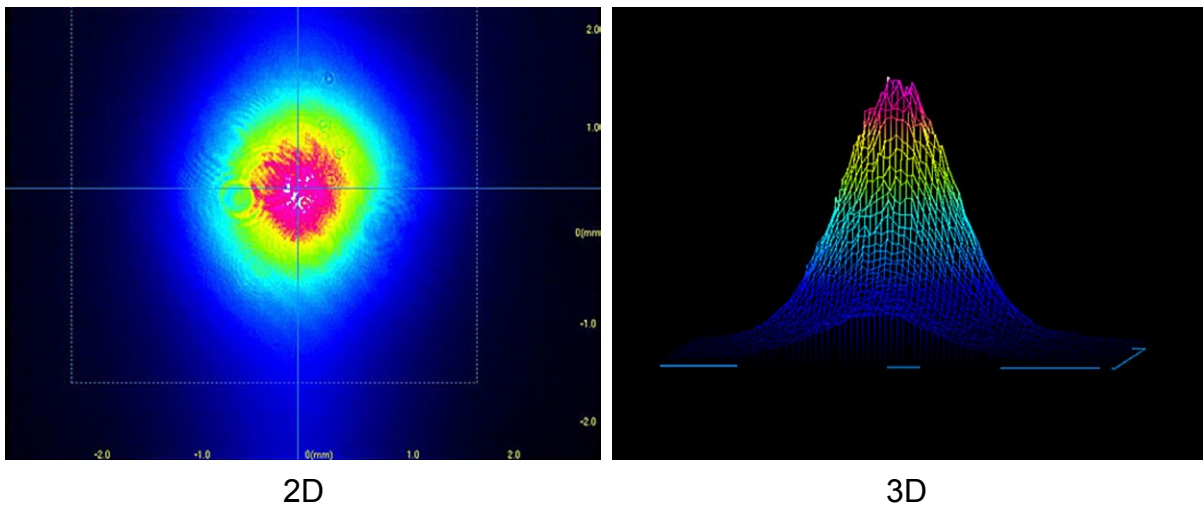

Camera Analysis:

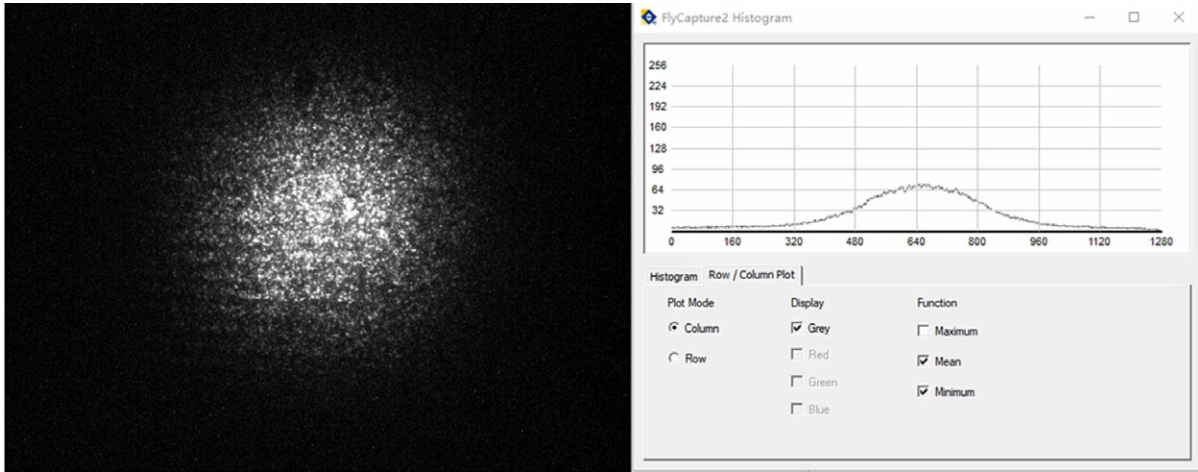

Package Size:

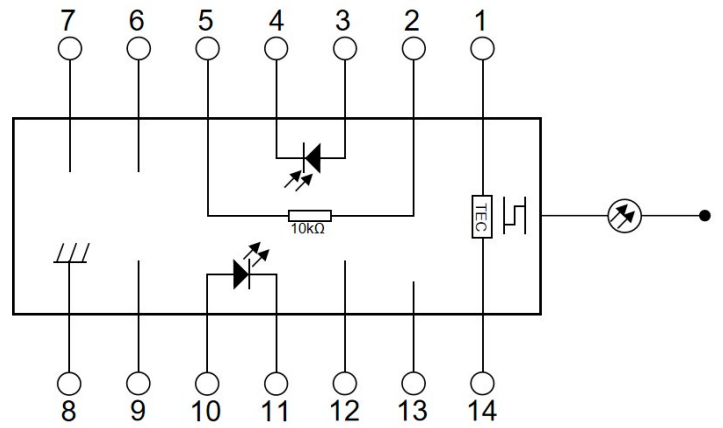
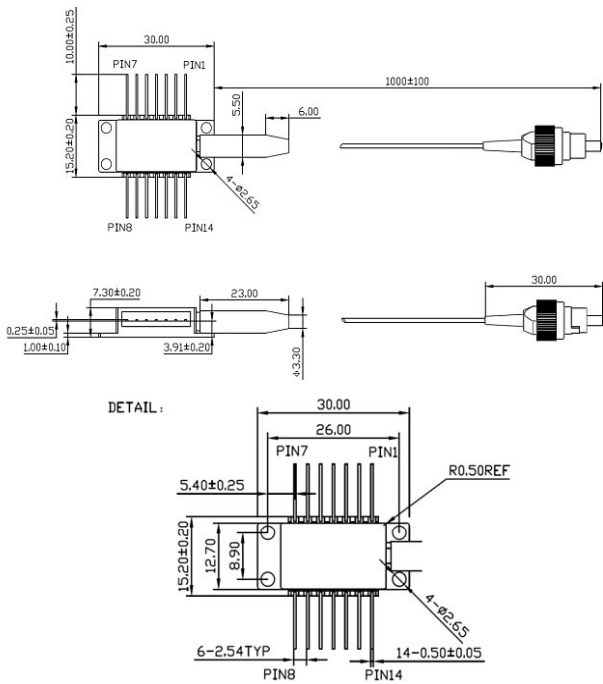

| PIN# | Function | PIN# | Function |
|------|------------|------|-------------------|
| 1 | TEC + | 8 | Case Ground |
| 2 | Thermistor | 9 | NC |
| 3 | Detector + | 10 | Laser Anode (+) |
| 4 | Detector - | 11 | Laser Cathode (-) |
| 5 | Thermistor | 12 | NC |
| 6 | NC | 13 | NC |
| 7 | NC | 14 | TEC - |

Absolute Maximum Ratings:

| Item | Unit | Min | Typ | Max |
|----------------------|------|-----|-----|-----|
| Case Temperature | °C | -5 | 25 | 70 |
| Chip Temperature | °C | +10 | 25 | 40 |
| Operating Current | mA | 0 | 100 | 150 |
| Forward Voltage | V | 0.8 | 1.2 | 1.8 |
| TEC Current | A | - | - | 1.2 |
| Reverse Voltage (LD) | V | - | - | 2.0 |
| Reverse Voltage (PD) | V | - | - | 20 |

Ordering Info:

PL-DFB-□□□□-☆-A8▽-XX

□□□□: Wavelength

1392: 1392nm

1512: 1512nm

1567: 1567nm

1572: 1572nm

1614.2: 1614.2nm

☆: Output Power

A: 10mW

B: 20mW

▽: Wavelength Tolerance

1: ±1nm

2: ±2nm

XX: Fiber and Connector Type

SA=SMF-28E+ FC/APC

SP=SMF-28E+ FC/PC

PP=PM Fiber+ FC/PC

PA=PM Fiber+ FC/APC