

HAL[®] 3960

Stray-Field Robust 2D Position Sensor
with 2-wire PWM Interface

3D | HAL[®]
Technology

master | HAL[®]
Technology

Copyright, Warranty, and Limitation of Liability

The information and data contained in this document are believed to be accurate and reliable. The software and proprietary information contained therein may be protected by copyright, patent, trademark and/or other intellectual property rights of TDK-Micronas. All rights not expressly granted remain reserved by TDK-Micronas.

TDK-Micronas assumes no liability for errors and gives no warranty representation or guarantee regarding the suitability of its products for any particular purpose due to these specifications.

By this publication, TDK-Micronas does not assume responsibility for patent infringements or other rights of third parties which may result from its use. Commercial conditions, product availability and delivery are exclusively subject to the respective order confirmation.

Any information and data which may be provided in the document can and do vary in different applications, and actual performance may vary over time.

All operating parameters must be validated for each customer application by customers' technical experts. Any mention of target applications for our products is made without a claim for fit for purpose as this has to be checked at system level.

Any new issue of this document invalidates previous issues. TDK-Micronas reserves the right to review this document and to make changes to the document's content at any time without obligation to notify any person or entity of such revision or changes. For further advice please contact us directly.

Do not use our products in life-supporting systems, military, aviation, or aerospace applications! Unless explicitly agreed to otherwise in writing between the parties, TDK-Micronas' products are not designed, intended or authorized for use as components in systems intended for surgical implants into the body, or other applications intended to support or sustain life, or for any other application in which the failure of the product could create a situation where personal injury or death could occur.

No part of this publication may be reproduced, photocopied, stored on a retrieval system or transmitted without the express written consent of TDK-Micronas.

TDK-Micronas Trademarks

- HAL
- 3D HAL
- masterHAL

Third-Party Trademarks

All other brand and product names or company names may be trademarks of their respective companies.

License Note

HAL 3960 uses licenses of Fraunhofer Institute for Integrated Circuits IIS.

Contents

Page	Section	Title
4	1.	Introduction
5	1.1.	Major Applications
5	1.2.	Features
6	2.	Ordering Information
6	2.1.	Device-Specific Ordering Codes
7	3.	Functional Description
7	3.1.	General Function
9	3.2.	Signal Path
10	3.3.	Register Definition
10	3.3.1.	RAM Registers
12	3.3.2.	EEPROM Registers
23	4.	Functional Safety
23	4.1.	Functional Safety Manual and Functional Safety Report
23	4.2.	Integrated Diagnostic Mechanism
25	5.	Specifications
25	5.1.	Outline Dimensions
27	5.2.	Soldering, Welding, Assembly
27	5.3.	Storage and Shelf Life Package
27	5.4.	Size and Position of Sensitive Areas
28	5.5.	Definition of Magnetic-Field Vectors
28	5.6.	Pin Connections and Short Description
29	5.7.	Absolute Maximum Ratings
30	5.8.	Recommended Operating Conditions
31	5.9.	Characteristics
35	5.10.	Magnetic Characteristics
38	5.11.	Temperature Sensor
39	6.	Application Notes
39	6.1.	Ambient Temperature
39	6.2.	EMC and ESD
40	6.3.	Application Circuit for HAL 3960
40	6.4.	Recommended Pad Size SOIC8 Package
41	7.	Programming of the Sensor
41	7.1.	Programming Interface
42	7.2.	Programming Environment and Tools
42	7.3.	Programming Information
43	8.	Document History

Stray-Field Robust 2D Position Sensor with 2-wire PWM Interface

1. Introduction

HAL 3960 is part of a new generation of TDK-Micronas' 3D position sensors addressing the need for stray-field robust 2D position sensors (linear and angular) as well as the ISO 26262 compliant development. It is a high-resolution position sensor for highly accurate position measurements.

HAL 3960 features a 2-wire PWM output. The PWM signals are transmitted via current consumption modulation. The PWM output is configurable with frequencies between 0.1 kHz and 2 kHz.

The device can measure 360° angular range and linear movements of a magnet. The device also features a so-called modulo function mainly used for chassis position sensor applications. With this mode it is possible to split the 360° measurement range into sub-segments (90°, 120° and 180°).

The device measures, based on Hall technology, vertical and horizontal magnetic-field components. It is able to suppress external magnetic stray-fields by using an array of Hall plates. Only a simple two-pole magnet is required to measure a rotation angle. Ideally, the magnet should be placed above the sensitive area in an end-of-shaft configuration. Stray-field robust off-axis measurements are supported as well.

On-chip signal processing calculates one angle out of the magnetic-field components and converts this value into a 2-wire PWM signal.

Major characteristics like gain and offset, reference position, etc. can be adjusted to the magnetic circuitry by programming the non-volatile memory.

This product is defined as SEooC (Safety Element out of Context) ASIL B ready according to ISO 26262.

The device is designed for automotive and industrial applications. It operates in the junction temperature range from -40 °C to 170 °C.

The sensor is available in the eight-pin SOIC8 SMD package.

1.1. Major Applications

Thanks to the sensor's versatile programming characteristics and its high accuracy, the HAL 3960 is a potential solution for the following application examples:

- Fuel-level measurements
- Non-contact potentiometer
- Transmission position detection

1.2. Features

- Accurate angular measurement up to 360° and linear position detection
- 2D position detection supporting transmission of one angle out of B_x , B_y , B_z
- Compensation of magnetic stray-fields (rotary or linear position detection)
- SEooC ASIL B ready according to ISO 26262 to support Functional Safety applications
- Wide supply voltage range of 4 V up to 11 V.
- Supply current modulated PWM signal
- 0.1 kHz to 2 kHz PWM
- Up to 8 kSps sampling frequency
- Operates from –40 °C up to 170 °C junction temperature
- Programming via supply voltage modulation. No additional programming pin required
- Various configurable signal processing parameter, like output gain and offset, reference position, temperature dependent offset, etc.
- Modulo function (90°/120°/180°) for chassis position applications
- Programmable arbitrary output characteristic with 17 variable or 33 fixed setpoints
- Programmable characteristics in a non-volatile memory (EEPROM) with redundancy and lock function
- Read access on non-volatile memory after customer lock
- On-board diagnostics of different functional blocks of the sensor

2. Ordering Information

A Micronas device is available in a variety of delivery forms. They are distinguished by a specific ordering code:

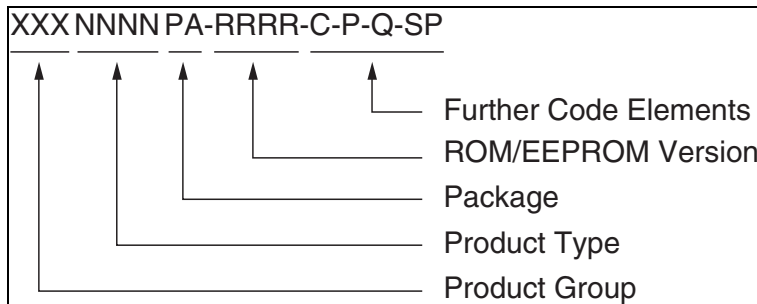

Fig. 2–1: Ordering code principle

For a detailed information, please refer to the brochure: “Sensors and Controllers: Ordering Codes, Packaging, Handling”.

2.1. Device-Specific Ordering Codes

The HAL 3960 is available in the following package.

Table 2–1: Available packages

Package Code (PA)	Package Type
DJ	SOIC8

For available variants for Configuration (C), Packaging (P), Quantity (Q), and Special Procedure (SP) please contact TDK-Micronas.

Table 2–2: Ordering Information

Product	Package	ROM/EEPROM Version	Further Code [-C-P-Q-SP]	Comments
HAL 3960	DJ = SOIC8	2300	See TDK-Micronas Ordering Information	

Table 2–3: Available ordering codes and corresponding package marking

Ordering Code	Package Marking	Description
HAL3960DJ-2300[-C-P-Q-SP]		Line 1: Product Type / ROM-ID Line 2: Lot number Line 3: Date code / Special Procedure SB (optional)

3. Functional Description

3.1. General Function

HAL 3960 is a 2D position sensor based on Hall-effect technology. The sensor includes an array of horizontal and vertical Hall plates based on TDK-Micronas' 3D HAL[®] technology. The array of Hall plates has a diameter C of 2.25 mm (nominal).

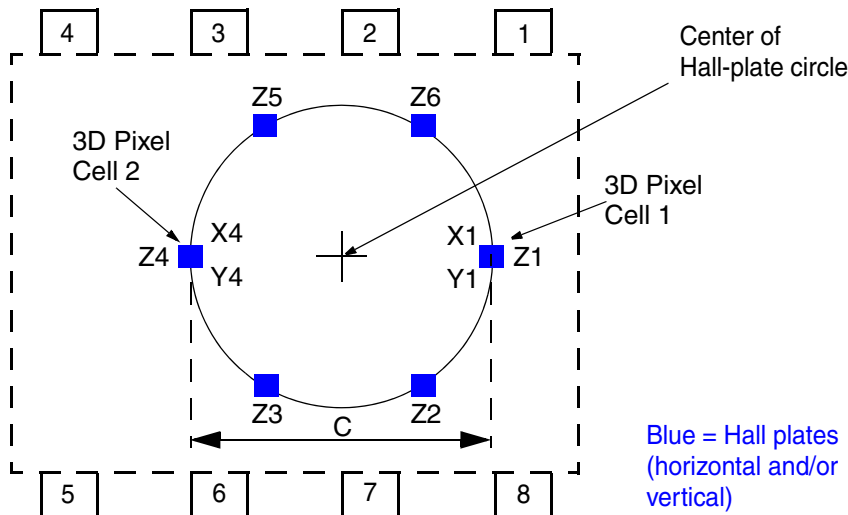

Fig. 3–1: Hall-plate position definition for HAL 3960

The Hall-plate signals are first measured by up to three A/D converters, filtered and temperature compensated. A linearization block can be used optionally to reduce the overall system angular non-linearity error, due to mechanical misalignment, magnet imperfections, etc.

On-chip offset compensation by spinning current minimizes the errors due to supply voltage and temperature variations as well as external package stress.

Stray-field compensation is done device inherent.

Depending on the measurement configuration different combination of Hall plates will be used for the magnetic-field sensing.

The sensor supports various measurement configurations:

- Angular measurements in a range between 0° and 360° with stray-field compensation
- Linear position detection with stray-field compensation based on the differential signals of the two 3D Pixel Cells
- 2D linear and angular position detection without stray-field compensation (B_Y/B_X , B_Z/B_X , B_Z/B_Y) with 3D Pixel Cell 1

The 360° angular range can be split into 90°/120°/180° sub-segments.

Overall, the in-system calibration can be utilized by the system designer to optimize performance for a specific system. The calibration information is stored in an on-chip non-volatile memory.

The calculated position information is transmitted via 2-wire PWM signals (supply-current modulation).

The HAL 3960 is programmable via modulation of the supply current. No additional programming pin is needed and fast end-of-line programming is enabled.

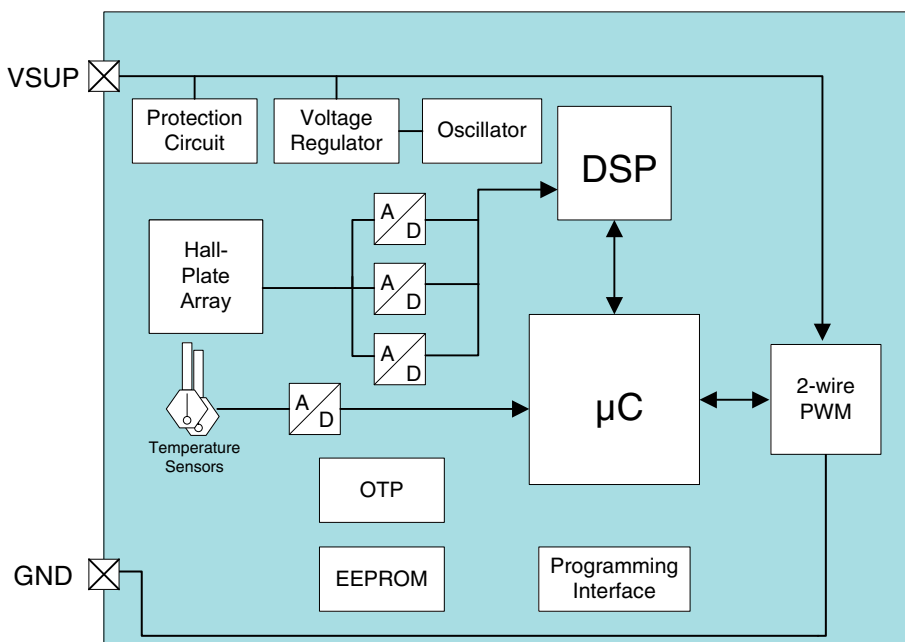
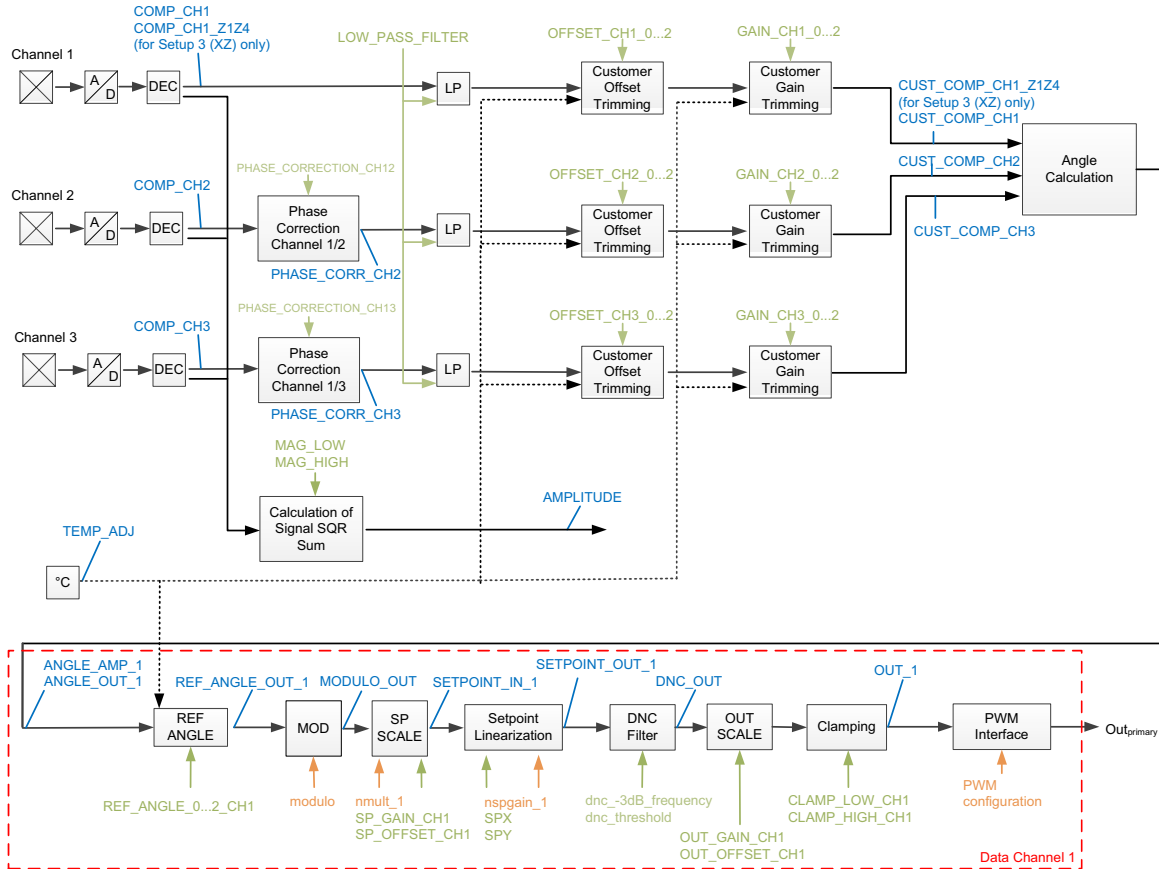

Fig. 3–2: HAL 3960 block diagram

3.2. Signal Path

The DSP part of this sensor performs the signal conditioning. The parameters for the DSP are stored in the non-volatile memory. Details of the overall signal path are shown in Fig. 3–3. Not all functions are available for all measurement modes. Depending of the measurement setup, the signal path is scaled to the needs for the measurement setup.



EEPROM register
EEPROM settings
RAM register
Sensor interfaces

Fig. 3–3: Signal path of HAL 3960

The sensor signal path contains two kinds of registers. Registers that are read-only and programmable registers (non-volatile memory). The read-only (RAM) registers contain measurement data at certain steps of the signal path and the non-volatile memory registers (EEPROM) change the sensor’s signal processing. EEPROM settings are individually configurable bits within an EEPROM register.

3.3. Register Definition

Note Further details about the programming of the device and detailed register setting description as well as memory map can be found in the document: HAL 3960 User Manual.

3.3.1. RAM Registers

TEMP_TADJ

The TEMP_TADJ register contains already the TDK-Micronas' compensated digital value of the sensor's junction temperature.

COMP_CH1, COMP_CH2 and COMP_CH3

COMP_CH1, COMP_CH2 and COMP_CH3 registers contain the TDK-Micronas' temperature compensated magnetic-field information of channel 1, channel 2 and channel 3.

COMP_CH1_Z1Z4

The COMP_CH1_Z1Z4 register is only available in case of Setup 3 and the $\Delta X \Delta Z$ mode. It contains the temperature compensated magnetic field information of the differential ΔZ magnetic-field $\Delta Z = Z4 - Z1$.

AMPLITUDE

The AMPLITUDE register contains sum of squares of the magnetic-field amplitude of all three channels calculated with the following equation. In case of two channels only the first two terms are used. This information is used for the magnet lost detection:

$$\text{AMPLITUDE} = \frac{\text{COMP_CH1}^2}{32768} + \frac{\text{COMP_CH2}^2}{32768} + \frac{\text{COMP_CH3}^2}{32768}$$

PHASE_CORR_CH2, PHASE_CORR_CH3

PHASE_CORR_CHx registers contain the customer compensated magnetic-field information of channel 2 and channel 3 after customer phase-shift error correction using the PHASE_CORRECTION_CHx registers.

CUST_COMP_CH1, CUST_COMP_CH2 and CUST_COMP_CH3

CUST_COMP_CH1, CUST_COMP_CH2 and CUST_COMP_CH3 registers contain the customer compensated magnetic-field information of channel 1, channel 2 and channel 3 used for the angle calculation. These register contain already the customer phase-shift, gain and offset corrected data.

CUST_COMP_CH1_Z1Z4

The CUST_COMP_CH1_Z1Z4 register is only available in case of Setup 3 and the $\Delta X \Delta Z$ mode. It contains the customer compensated magnetic field information of the differential ΔZ magnetic-field $\Delta Z = Z4 - Z1$ used for the angle calculation.

ANGLE_OUT_1

The ANGLE_OUT_1 register contains the digital value of the position calculated by the angle calculation algorithm.

ANGLE_AMP_1

The ANGLE_AMP_1 register contains the digital value of the magnetic-field amplitude calculated by the angle calculation algorithm.

REF_ANGLE_OUT_1

The REF_ANGLE_OUT_1 register contains the digital value of the angle information after setting the reference angle defining the zero angle position.

MODULO_OUT

The MODULO_OUT register contains the digital value of the angle information after applying the modulo calculation algorithm.

SETPOINT_IN_1

The SETPOINT_IN_1 register contains the digital value of the angle information after the setpoint scaling block and are the values used for the input of the setpoint linearization block.

SETPOINT_OUT_1

The SETPOINT_OUT_1 register contains the digital value of the angle information after the setpoint linearization block.

DNC_OUT

The DNC_OUT register contains the digital value of the angle information after the DNC filter. DNC_OUT is only available for the primary angle output.

OUT_1

The OUT_1 register contains the digital value of the angle information after all signal processing steps and depend on all customer configuration settings.

DIAGNOSIS

The DIAGNOSIS_0 and DIAGNOSIS_1 registers report certain failures detected by the sensor. HAL 3960 performs self-tests during power-up as well as continues system integrity tests during normal operation. The result of those tests is reported via the DIAGNOSIS_X registers (further details can be found in see Section 4.2. on page 23).

Micronas IDs

The MIC_ID1 and MIC_ID2 registers are both 16-bit organized. They are read only and contain TDK-Micronas production information, like X,Y position on the wafer, wafer number, etc.

3.3.2. EEPROM Registers

Application Modes

HAL 3960 can be configured in different application modes. Depending on the required measurement task one of the application modes can be selected. The register SETUP_FRONTEND (Table 3–1 on page 21) defines the different available modes.

– Setup 1: 180° rotary (stray-field compensated)

This mode uses six horizontal Hall-plates to measure a 180° angular range. It requires a 4-pole magnet. Speciality of this mode is that the device can compensate stray-fields according to ISO 11452-8 definition as well as disturbing gradients generated for example by a current conducting wire. Fig. 3–4 shows the related signal path.

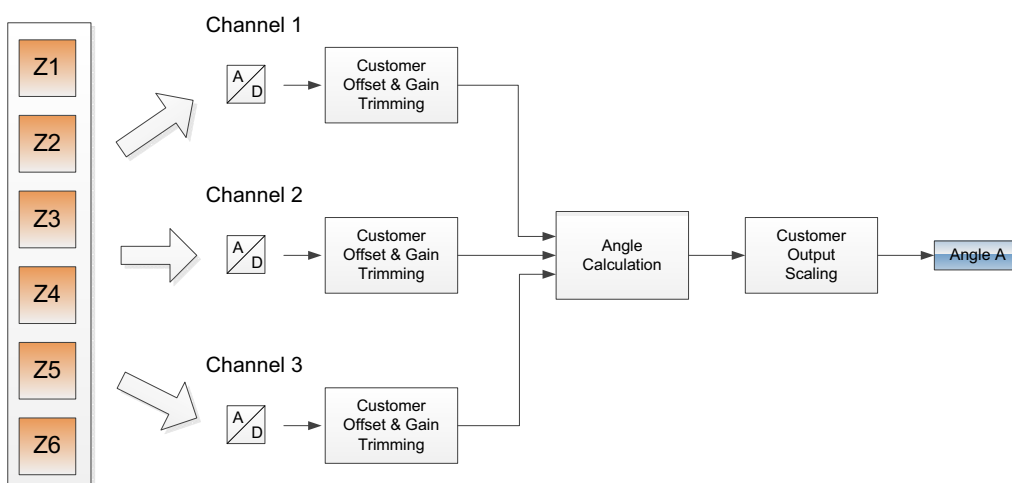

Fig. 3–4: Signal path diagram of setup 1 (stray-field robust 180° measurement)

– Setup 2: 360° rotary (stray-field compensated)

This mode uses horizontal Hall-plates to measure a 360° angular range. It requires a 2-pole magnet. The device can compensate stray-fields according to ISO 11452-8 definition. Fig. 3–5 shows the related signal path.

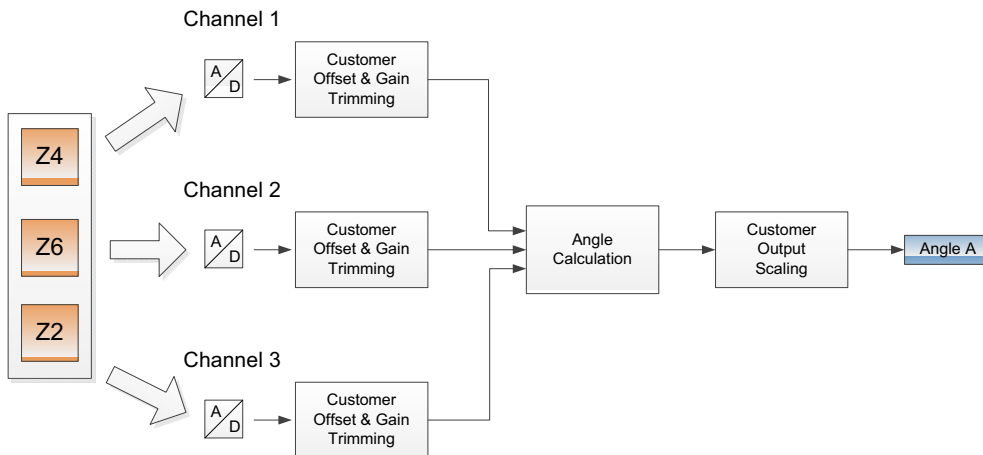

Fig. 3–5: Signal path diagram of setup 2 (stray-field robust 360° measurement)

– Setup 3: Linear movement or off-axis rotary (stray-field compensated)

This mode uses a combination of horizontal and vertical Hall-plates to measure a stray-field compensated linear movement (ΔB_X & ΔB_Z of 3D Pixel Cells 1 and 2). Alternatively this setup can be used as well for off-axis stray-field compensated angular measurements in case that a combination of vertical Hall-plates is selected (ΔB_X & ΔB_Y of 3D Pixel Cells 1 and 2). The device can compensate stray-fields according to ISO 11452-8 definition. Fig. 3–6 shows the related signal path for $\Delta X\Delta Y$ setup and Fig. 3–7 the signal path for $\Delta X\Delta Z$ setup.

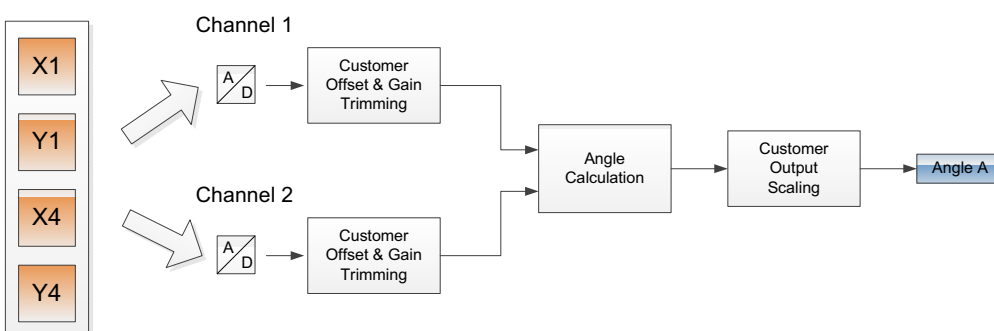

Fig. 3–6: Signal path diagram of setup 3a - $\Delta X\Delta Y$ (stray-field robust off-axis position detection)

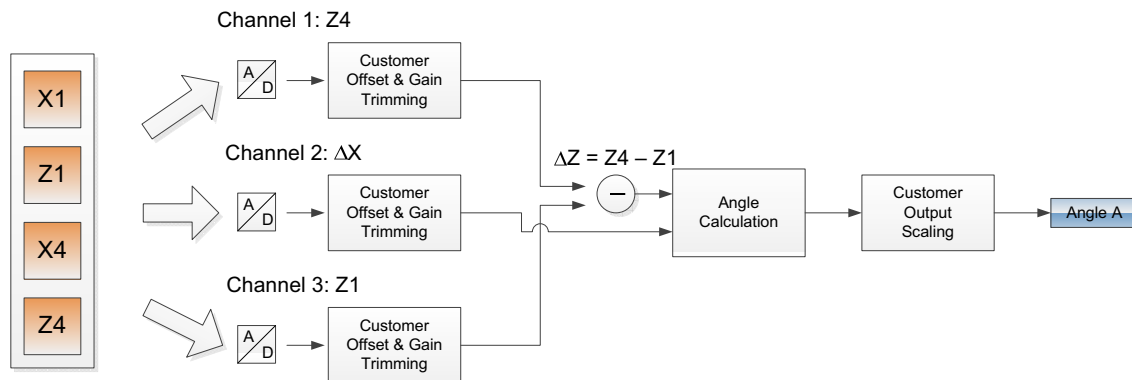

Fig. 3–7: Signal path diagram of setup 3b - $\Delta X\Delta Z$ (stray-field robust linear position detection)

For the linear movement setup the angle calculation is done by using the following equation:

$$\text{ALPHA} = \text{ATAN2}\left(\frac{\Delta BZ}{\Delta BX}\right) = \text{ATAN2}\left(\frac{BZ_4 - BZ_1}{BX_4 - BX_1}\right)$$

For the off-axis rotary setup the angle calculation is done by using the following equation:

$$\text{ALPHA} = \text{ATAN2}\left(\frac{\Delta BY}{\Delta BX}\right) = \text{ATAN2}\left(\frac{BY_4 - BY_1}{BX_4 - BX_1}\right)$$

Note GAIN_CH1_0...2 and GAIN_CH3_0...2 must be set to the same value for this specific setup (3b). OFFSET_CH3_0...2 must be set to zero.

– Setup 4a: 360° rotary or linear movement measurement without stray-field compensation

This mode uses horizontal and vertical Hall-plates to measure B_x , B_y , B_z of Pixel Cell 1. The angle will be calculated out of combinations of B_y/B_x , B_z/B_x or B_z/B_y . This mode does not compensate stray-fields. The measurement setup is similar to the well known HAL 37xy family from TDK-Micronas.

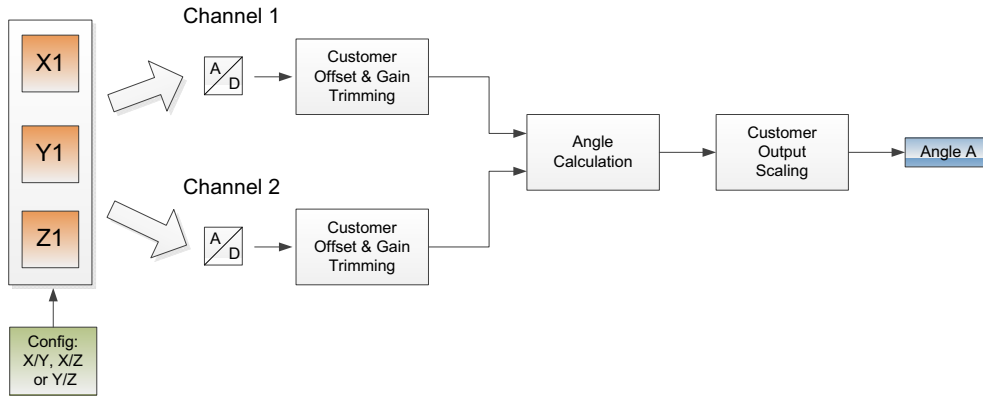

Fig. 3–8: Signal path diagram of setup 4a (rotary or linear position detection w/o stray-field compensation)

– Setup 4b: Virtual centered pixel cell mode for 360° rotary or linear movement measurement (w/o stray-field compensation)

In addition to setup 4a, it is possible to select a virtual centered pixel cell mode (4b). In this mode the signals in X and Y direction of both Pixel Cells P1 and P2 are combined and averaged to generate one virtual centered pixel in the middle of the Hall-Plate array.

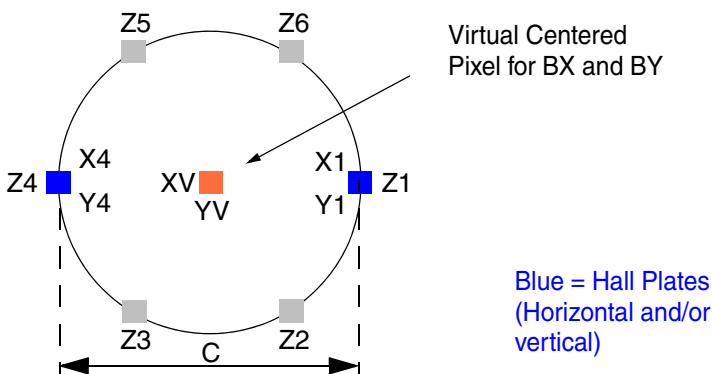

Fig. 3–9: Virtual centered pixel for B_x and B_y in mode 4b

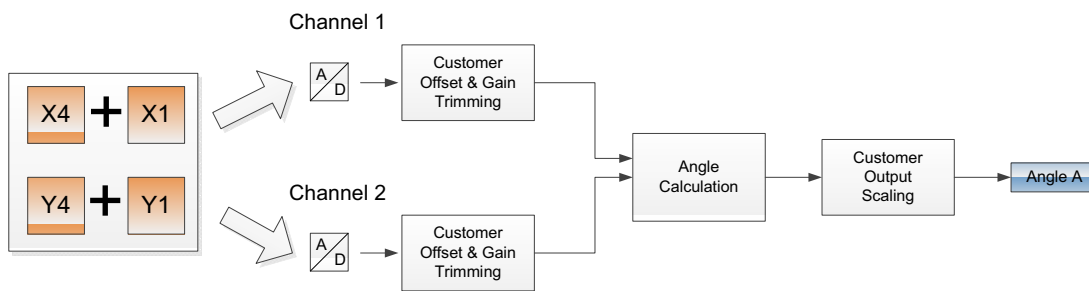

Fig. 3–10: Signal path diagram of setup 4b (virtual centered pixel w/o stray-field compensation)

$$B_{XV} = \left(\frac{BX_1 + BX_4}{2} \right)$$

$$B_{YV} = \left(\frac{BY_1 + BY_4}{2} \right)$$

Customer IDs

The customer ID registers (CUSTOMER_ID0 to CUSTOMER_ID9) contain of 10 times 16-bit words and can be used to store customer production information, like serial number or project information.

Magnetic Range Check

The magnetic range check uses the AMPLITUDE register value and compares it with an upper and lower limit threshold defined by the customer programmable registers MAG_LOW and MAG_HIGH. If either low or high limit is exceeded, the sensor will indicate an error.

Mag-Low Limit

MAG_LOW defines the low level for the magnetic-field range check function.

Mag-High Limit

MAG-HIGH defines the high level for the magnetic-field range check function.

MAG_LOSS_OUTPUT

The device will transmit the register value as PWM duty-cycle in case of magnet loss detection (AMPLITUDE is below the Mag-Low limit). The 12 LSB's are used for the 2 kHz PWM frequency and the 13 LSB's for all other frequencies. Default value is (0x0FAD = 98% for the 12 bit value).

Phase Correction

PHASE_CORRECTION_CH12 and PHASE_CORRECTION_CH13 can be used to compensate a phase shift of channel 2 and channel 3 in relation to channel 1.

Neutral value for the registers is zero (no phase-shift correction).

Low-Pass Filter

With the LOW_PASS_FILTER register it is possible to select different –3 dB frequencies for HAL 3960. The default value is zero (low pass filter disabled). The filter frequency is valid for all channels.

OFFSET_CHx_0...2

OFFSET_CH1_0...2, OFFSET_CH2_0...2 and OFFSET_CH3_0...2 support three polynomials of second order and describe the temperature compensation of the offset of channel 1, channel 2, and channel 3 (compensating a remaining offset in each of the three channels). This means a constant, linear and quadratic offset factor can be programmed for up to three channels (temperature dependent offset).

Note OFFSET_CH3_0...2 must be set to zero in case of Setup 3 with $\Delta X\Delta Z$ mode.

GAIN_CHx_0...2

GAIN_CH1_0...2, GAIN_CH2_0...2 and GAIN_CH3_0...2 support three polynomials of second order and describe the temperature compensation of the sensitivity of channel 1, channel 2 and channel 3 (compensating the amplitude mismatches between three channels). This means a constant, linear and quadratic gain factor can be programmed individually for the three channels (temperature dependent gain).

Note GAIN_CH3_0...2 must be set to the same value of GAIN_CH1_0...2 in case of Setup 3 with $\Delta X\Delta Z$ mode

Reference Angle Position

The output signal zero position defines the reference position for the angle output and therefore it is possible to shift the discontinuity point in the output characteristics out of the measurement range with these parameters. It can be set to any value of the angular range.

REF_ANGLE_0...2_CH1 defines a polynomial of second order with REF_ANGLE_0_CH1 (constant part), REF_ANGLE_1_CH1 (linear part) and REF_ANGLE_2_CH1 (quadratic part).

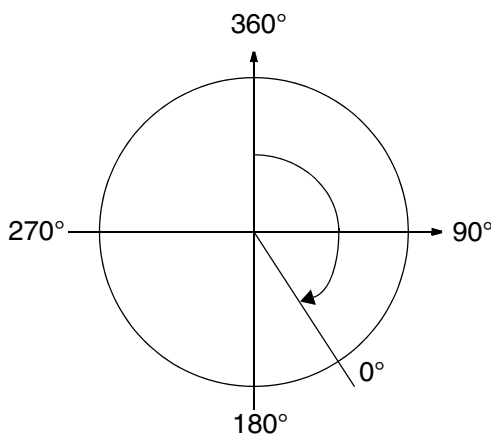

Fig. 3–11: Example definition of zero degree point

Modulo Select

HAL 3960 can split the 360° measurement range into sub-ranges of 90°, 120° and 180°. For example in the 90° sub-range output signal is repeating after 90°. The MODULO register can be used to select between these four different output ranges. Modulo function can only be applied on the primary output channel.

The desired modulo calculation can be selected by setting certain bits in the SETUP_FRONTEND register.

nmult_1 (EEPROM Setting)

nmult_1 defines the gain exponent for the setpoint scaling block on the data channel. The factor is multiplied by SP_GAIN_CH1 to achieve gain factors up to 128. (SETUP_DATAPATH[7:5] bits (= nmult_1)).

Setpoint Gain

SP_GAIN_CH1 defines the output gain for the data channel. It is used to scale the position information to the input range of the linearization block.

Setpoint Offset

SP_OFFSET_CH1 defines the output offset for the data channel.

Setpoint Linearization

The setpoint linearization block enables the linearization of the sensor's output characteristic for the customer's application. For fixed setpoints it consists of 33 setpoints for one data channel (SP0, SP1, ..., SP32) or 34 setpoints for two channels (17 setpoints each data channel; two times SP0, SP1, ..., SP16). Each setpoint is defined by its fixed x position and its programmable y value. The setpoint x positions (SP(n)_X) are equally distributed between $-32768 \dots 32767$ LSB along the signal range.

If variable setpoints are enabled (SETUP_DATAPATH[0] = 1), both position values (x and y) of the setpoints are programmable.

The setpoint registers have a length of 16 bits and are two's complement coded. Therefore the setpoint register values can vary between $-32767 \dots 32767$ LSB. The setpoint x values are stored as absolute values and the setpoint y values differentially to the corresponding x values. The setpoint register values are initially set to 0 (neutral) by default.

The setpoint linearization block works in a way that the incoming signal (SETPOINT_IN_1 value) is interpolated linearly between two adjacent setpoints (SP(n) and SP(n+1)). The resulting SETPOINT_OUT_1 register value represents the angular information after the setpoint scaling.

In case of variable setpoints are selected nspgain_1 register must be used.

nspgain_1 (EEPROM Settings)

The SETUP_DATAPATH[4:1] bits (= nspgain_1) set the gain exponent for the setpoint slope on the data channel. With the 4 bits it is possible to get gains up to 65536.

DNC Filter Registers (dnc_–3dB_frequency & dnc_threshold)

The DNC (Dynamic Noise Cancellation) filter decreases the output noise significantly by adding a low-pass filter with a very low cut-off frequency for signals below a certain signal change threshold (dnc_threshold, DNC[15:8]). The attenuation factor dnc_–3dB_frequency of this IIR filter can be selected by the bits DNC[7:0] of the DNC registers. Both parameters have a length of 8 bits.

Signals with a very low amplitude (signals classified as noise e.g. $\pm 0.5^\circ$) and periodic movements with an amplitude lower than 1° will be filtered whereas signals with a higher amplitude are untouched (i. e. rapid movements). The activation of the DNC filter has no impact on the resolution of the output and does not add any additional processing delay.

For dnc_threshold only values from 0 to 255 are allowed. For the dnc_–3dB_frequency only cutoff frequencies up to 50% of the sample frequency ($0.5 * f_{dec sel}$) are allowed. To disable the DNC filter both registers must be set to 0.

OUT_OFFSET_CH1

The register `OUT_OFFSET_CH1` is used as the final offset scaling stage for the desired output signal. The register has a length of 16 bits and is two's complement-coded.

OUT_GAIN_CH1

The register `OUT_GAIN_CH1` is used as the final gain scaling stage for the desired output signal. It can also be used to invert the output signal. The register has a length of 16 bits and is two's complement-coded.

Clamping Levels (CLAMP-LOW & CLAMP-HIGH)

The clamping levels `CLAMP_LOW_CH1` and `CLAMP_HIGH_CH1` define the maximum and minimum output values. Both registers have a length of 16 bits and are two's complemented coded. Both clamping levels can have values between 0 % and 100 %.

PWM_STD_ERROR

The `PWM_STD_ERROR` register defines the output duty-cycle for the PWM output in case of an internal error (except `MAG_LOW` or under-/overvoltage error indication). The 12 LSB's are used for the 2 kHz PWM frequency and the 13 LSB's for all other frequencies. Default value is (0x0FEB = 99.5% for the 12 bit value).

Supply Voltage Supervision

As the device supports a wide supply voltage range it is beneficial to enable customer programmable under/overvoltage detection levels. The register `UV_LEVEL` defines the undervoltage detection level in mV and `OV_LEVEL` the overvoltage detection level. The `SUPPLY_SUPERVISION` register has a length of 16 bits. `OV_LEVEL` uses the 8 MSBs and `UV_LEVEL` the 8 LSBs. For both levels, 1 LSB is typically equal to 100 mV.

Customer Configuration Registers

SETUP_FRONTEND, SETUP_DATAPATH and SETUP_OUTPUT register are 16-bit registers that enable the customer to activate various functions of the sensor.

The following tables describe in detail the available combinations and resulting functions.

Table 3–1: SETUP_FRONTEND

Bit No.	Function	Description				
15	customer_lock	Customer Lock: 0: Unlocked 1: Locked				
14:8	-	Must be set to 0.				
7:6	modulo	Modulo operation: 00: 360° 01: Modulo 90° 10: Modulo 120° 11: Modulo 180°				
5:4	fdecsel	A/D converter sample frequency: 00: 2 kSps 01: 4 kSps 10: 8 kSps 11: not supported				
3:0	meas_config	Measurement setups: 0000: Setup 4a - 2D 0001: Setup 4a - 2D 0010: Setup 4a - 2D 0011: Setup 3b - 2D - Strayfield compensated 0100: Setup 3a - 2D - Strayfield compensated 0101: Setup 4b - 2D - Virtual centered pixel 0110: Setup 1 - 180° rotary - strayfield compensated 0111: Setup 2 - 360° rotary - strayfield compensated 1000 to 1111: Must not be used	Correspond. Signal Path With two channels With two channels With two channels With two channels With two channels With two channels 6 Z Hall-plates 3 Z Hall-plates -	CH1 X1 Z1 Z1 Z4 X4-X1 X1+X4 Z1+Z4 Z4 -	CH2 Y1 Y1 X1 X4-X1 Y4-Y1 Y1+Y4 Z2+Z5 Z6 -	CH3 - - - Z1 - - Z3+Z6 Z2 -

Table 3–2: SETUP_DATAPATH

Bit No.	Function	Description
15:8	-	Reserved
7:5	nmult_1	Gain exponent for SETPOINT_IN1: $SP_GAIN = SP_GAIN_CH1 * [2^{(nmult_1)}]$
4:1	nspgain_1	Gain exponent for setpoint slope in channel 1: $Slope = SPGn * (2^{nspgain_1} + 1)$
0	variable_setpoints	Fixed/variable setpoint selection: 0: Fixed setpoints 1: Variable setpoints

The SETUP_OUTPUT register is used to define the error behavior of the PWM signal and the signal frequencies. Further details can be found in table (Table 3–3).

Table 3–3: SETUP_OUTPUT

Bit No.	Function	Description
15:8	-	Reserved
6	pwm_uvov_diag	Output behavior for undervoltage/overvoltage detection 0: Will be signalized as selected for all other diagnosis bits 1: Will be signalized with 2 % duty-cycle
7	pwm_current_mode	Defines the delta current level ($I_{SUP,high} = I_{SUP,Low} + \Delta I_{SUP}$): 0: 13 mA 1: 26 mA
5	pwm_inverted	PWM inverted: 0: Disabled 1: Enabled
4	-	Reserved
3:0	pwm_frequency	Min. PWM frequency 0000: 2.0 kHz 0001: 1.5 kHz 0010: 1.0 kHz 0011: 800 Hz 0100: 550 Hz 0101: 500 Hz 0110: 250 Hz 0111: 200 Hz 1000: 150 Hz 1001: 125 Hz 1010: 100 Hz 1011 to 1111: Not allowed Typical values are 3% higher.

4. Functional Safety

4.1. Functional Safety Manual and Functional Safety Report

The Functional Safety Manual for HAL 3960 contains the necessary information to support customers to realize a safety compliant application by integrating HAL 3960 as an ASIL B ready component, in their system. The Functional Safety Manual can be provided upon request.

The Functional Safety Analysis Report describes the assumed Safety Goal, the corresponding Failure Modes as well as the Base Failure Rate for die and package according to IEC TR 62380. It can be provided based on a TDK-Micronas mission profile as well as customer mission profiles.

4.2. Integrated Diagnostic Mechanism

HAL 3960 performs self-tests during start-up and normal operation. These increase the robustness of the device functionality by either preventing the sensor to provide wrong output signals or by reporting the failure via diagnostic levels

The sensor signalizes errors by providing a fixed duty-cycle. This duty-cycle can be defined by the registers PWM_STD_ERROR and MAG_LOSS_OUTPUT. Additionally, it is possible to report under- and overvoltage events with a separate duty-cycle of 2%. The behavior is customer configurable. Further details can be found in Section 3.3.2. on page 12.

The result of the internal diagnostics is as well available via the DIAGNOSIS_X registers.

Table 4–1: DIAGNOSIS_0 register

Bit no.	Description when bit is set to 1
15	DSP self-check routines (redundancy or plausibility checks)
14	DSP and μ C check of 16-bit checksum covering the EEPROM parameters
13	DSP checksum for ROM and RAM
12	Chip junction temperature out of range
11	Plausibility check of redundant temperature sensor
10	Hall-plate supply too high
9	Hardware overtemperature supervision: Junction temperature > 180°C
8	Reserved
7	At least one of the A/D converters delivers a stuck signal for Channel 1, 2 or 3
6	Overflow or underflow of decimation filter
5	MAG_HIGH threshold has been exceeded
4	Magnetic field amplitude is below the MAG-LOW threshold

Table 4–1: DIAGNOSIS_0 register, continued

Bit no.	Description when bit is set to 1
3	The result of the position calculation (high) is out of the expected (valid) range
2	The result of the position calculation (low) is out of the expected (valid) range
1	Hall-plate current out of range
0	Reserved

Table 4–2: DIAGNOSIS_1 register

Bit no.	Description when bit is set to 1
15	Reserved
14, 12	General purpose ADC error
13	Reserved
11	Undervoltage Error. Supply voltage out of range
10	Overvoltage Error. Supply voltage out of range.
9	Internal analog voltage out of range
8	Internal digital voltage out of range
Note: Bits[7:0] can not be read via the programming interface as they are triggering immediately a reset of the device.	
7	µC self-test error
6	µC ROM OP code error
5	µC memory OP code error
4:2	Reserved
1	Error in analog part
0	Reserved

5. Specifications

5.1. Outline Dimensions

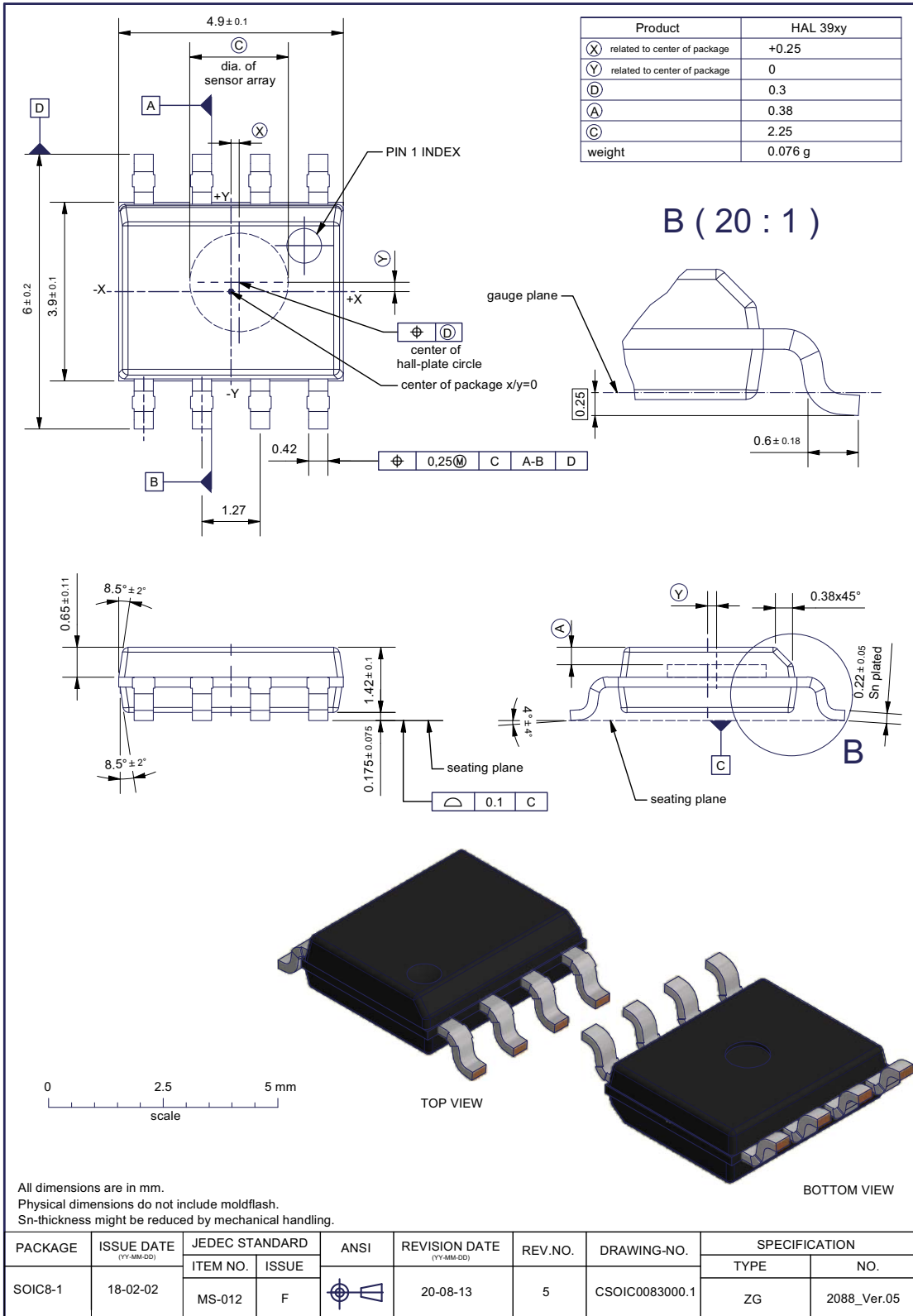

All dimensions are in mm.
Physical dimensions do not include moldflash.
Sn-thickness might be reduced by mechanical handling.

PACKAGE	ISSUE DATE (YY-MM-DD)	JEDEC STANDARD		ANSI	REVISION DATE (YY-MM-DD)	REV.NO.	DRAWING-NO.	SPECIFICATION	
		ITEM NO.	ISSUE					TYPE	NO.
SOIC8-1	18-02-02	MS-012	F		20-08-13	5	CSOIC0083000.1	ZG	2088_Ver.05

© Copyright 2018 TDK-Micronas GmbH, all rights reserved

Fig. 5-1:
SOIC8-1: Plastic Small Outline IC package, 8 leads, gullwing bent, 150 mil
Ordering code: DJ

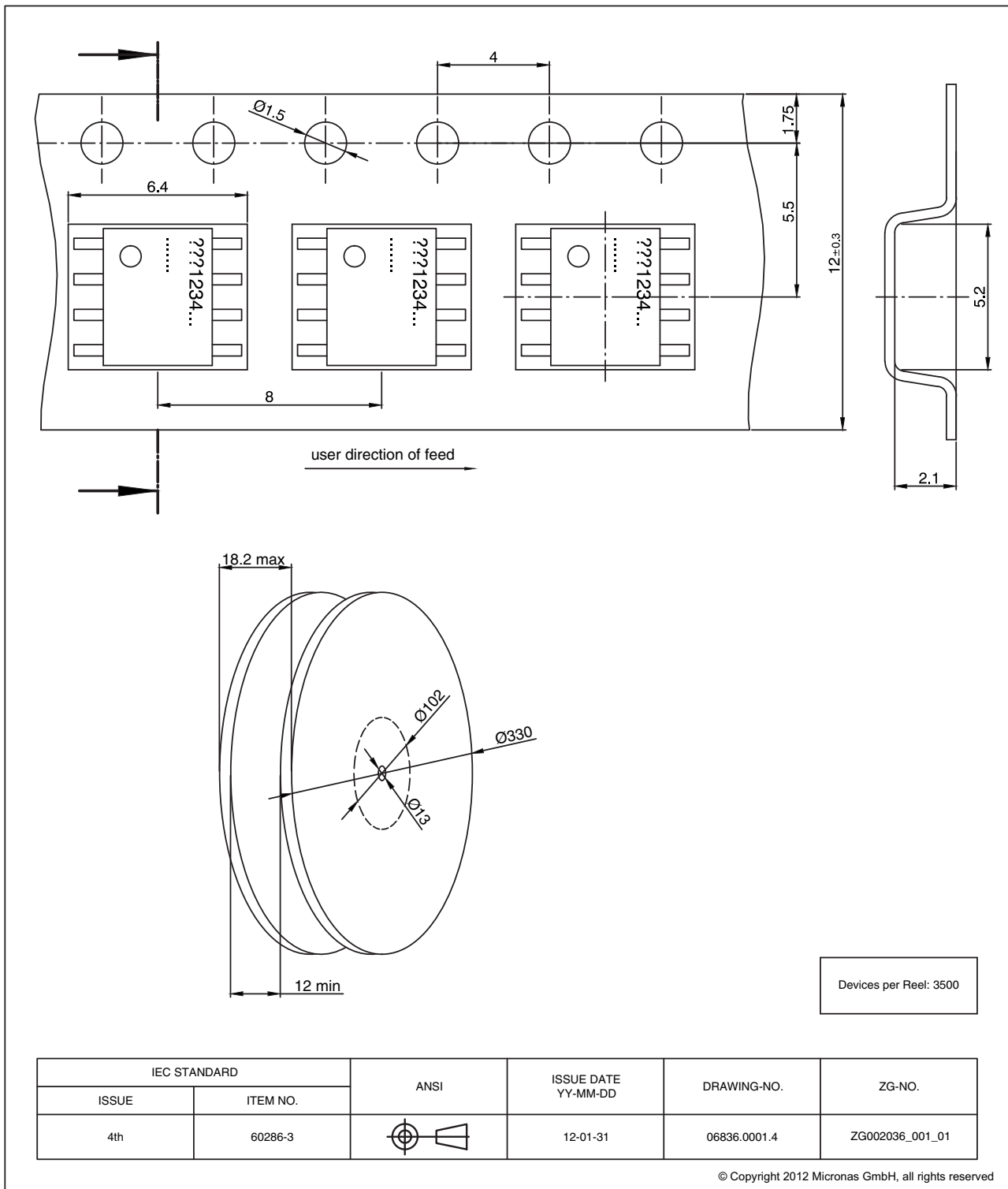

Fig. 5-2:
SOIC8-1: Dimensions Tape & Reel

5.2. Soldering, Welding, Assembly

Information related to solderability, welding, assembly, and second-level packaging is included in the document “Guidelines for the Assembly of Micronas Packages”. It is available on the TDK-Micronas website (<https://www.micronas.tdk.com/en/service-center/downloads>) or on the service portal (<http://service.micronas.com>).

5.3. Storage and Shelf Life Package

Information related to storage conditions of TDK-Micronas sensors is included in the document “Guidelines for the Assembly of Micronas Packages”. It gives recommendations linked to moisture sensitivity level and long-term storage. It is available on the TDK-Micronas website (<https://www.micronas.tdk.com/en/service-center/downloads>) or on the service portal (<http://service.micronas.com>).

5.4. Size and Position of Sensitive Areas

Diameter of Hall plate circle: $C = 2.25 \text{ mm}$

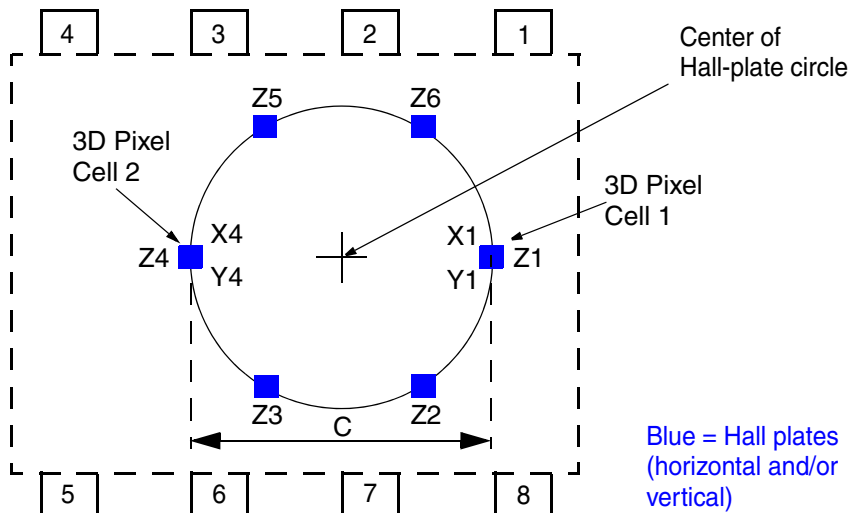

Fig. 5–3: Hall-plate configuration

5.5. Definition of Magnetic-Field Vectors

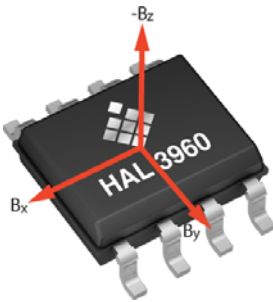

Fig. 5–4: Definition of magnetic-field vectors for HAL 3960

5.6. Pin Connections and Short Description

Table 5–1: Pin connection SOIC8

Pin No.	Pin Name	Type	Short Description
SOIC8 Package			
1	VSUP	IN	Supply voltage
2	GND	GND	Ground
3	TEST1	IN	Test
4	TEST2	I/O	Test
5	TEST3	OUT	Test
6	TEST4	N/A	Test
7	TEST5	N/A	Test
8	TEST6	N/A	Test

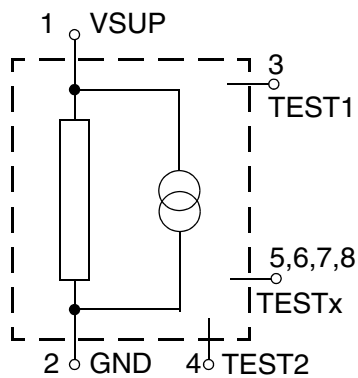

Fig. 5–5: Pin configuration for SOIC8 package

Note Pin 2 must be connected to GND. Pins 3, 4, 5, 6, 7, and 8 must stay open.

5.7. Absolute Maximum Ratings

Stresses beyond those listed in the “Absolute Maximum Ratings” may cause permanent damage to the device. This is a stress rating only. Functional operation of the device at these conditions is not implied. Exposure to absolute maximum rating conditions for extended periods will affect device reliability.

This device contains circuitry to protect the inputs and outputs against damage due to high static voltages or electric fields; however, it is advised that normal precautions must be taken to avoid application of any voltage higher than absolute maximum-rated voltages to this high-impedance circuit.

All voltages listed are referenced to ground (GND).

Symbol	Parameter	Pin Name	Min.	Max.	Unit	Condition
V _{SUP}	Supply Voltage	VSUP	-18	28 37	V V	t < 60 s; T _J = 25 °C
B _{max}	Magnetic Field	-	-1	1	T	
T _J	Junction Temperature	-	-40	190	°C	t < 96 h ¹⁾
T _{storage}	Transportation/Short Term Storage Temperature	-	-55	150	°C	Device only without packing material
V _{ESD}	ESD Protection	VSUP, GND, TEST _x	-2	2	kV	²⁾
		VSUP, GND	-4	4	kV	³⁾

No cumulative stress for all parameters.

¹⁾ Please contact TDK-Micronas for other temperature requirements

²⁾ AEC-Q100-002 (100 pF and 1.5 kΩ)

³⁾ Unpowered gun test (150 pF/330 Ω or 330 pF/2 kΩ) according to ISO 10605-2008 with additional protection on the PCB (10 nF on VSUP)

5.8. Recommended Operating Conditions

Functional operation of the device beyond those indicated in the “Recommended Operating Conditions/Characteristics” is not implied and may result in unpredictable behavior, reduced reliability and lifetime of the device.

All voltages listed are referenced to ground (GND).

Symbol	Parameter	Pin Name	Min.	Typ.	Max.	Unit	Condition
V _{SUP}	Supply Voltage	VSUP	4.0	–	11	V	
C _{VSUP}	Supply Capacitor	VSUP	10	–	–	nF	
N _{PRG}	Number of Memory Programming Cycles	–	–	–	100	cycles	0 °C < T _{amb} < 55 °C
B _{AMP}	Recommended Magnetic-Field Amplitude	–	±10	–	±130	mT	Max. value for setup 4b is ±65 mT
T _J	Junction Temperature ¹⁾²⁾		–40	–	170	°C	for 1000 h

¹⁾ Depends on the temperature profile of the application. Please contact TDK-Micronas for life time calculations.
²⁾ Impact of the supply voltage on the junction temperature needs to be considered

Note It is possible to operate the sensor with magnetic fields down to ±5 mT. For magnetic fields below ±10 mT, the sensor performance will be reduced.

5.9. Characteristics

at $T_J = -40\text{ °C}$ to 155 °C , $V_{SUP} = 4.0\text{ V}$ to 11.0 V , $GND = 0\text{ V}$, after programming and locking of the sensor, at Recommended Operation Conditions if not otherwise specified in the column “Conditions”.

Typical Characteristics for $T_J = 25\text{ °C}$ and $V_{SUP} = 5\text{ V}$.

Symbol	Parameter	Pin Name	Limit Values			Unit	Conditions
			Min.	Typ.	Max.		
$I_{SUP,Low}$	Low Level Sink Current	VSUP	5	8	12	mA	1)
$I_{SUP,High}$	High Level Sink Current	VSUP	16	21	27	mA	1)pwm_current_mode = 0
			–	34	–	mA	1)pwm_current_mode = 1
$I_{SUP,Ripple}$	Ripple on Supply Current (peak-to-peak value)	VSUP	–	–	1.5	mA	1)
f_{osc}	Internal Oscillator Frequency		–	32	–	MHz	
f_{sample}	Sampling Frequency		–	1.953	–	kSps	2) Configurable
			–	3.906	–		
			–	7.812	–		
Power-On Behavior							
V_{POR}	Power_On Reset Voltage	VSUP	2.1	2.6	2.9	V	
$V_{PORHyst}$	Power_On Reset Voltage Hysteresis	VSUP	–	200	–	mV	
Overvoltage and Undervoltage Detection							
$S_{VSUP,UOV}$	Step Size of Under-/Overvoltage Supervision Threshold	VSUP	92	100	108	mV/LSB	Under-/Overvoltage threshold is customer configurable (see page 20). 1)
$S_{VSUP,UOVhys}$	Under-/Overvoltage Detection Level Hysteresis	VSUP	–	1	–	LSB	1) 1 LSB typ. 100 mV
1) Characterized on small sample size, not tested							
2) Guaranteed by design							

Symbol	Parameter	Pin Name	Limit Values			Unit	Conditions
			Min.	Typ.	Max.		
f _{PWM}	PWM Output Frequency	VSUP	100	–	106.2	Hz	1)
			125	–	132.5	Hz	
			150	–	159.3	Hz	
			200	–	212.4	Hz	
			250	–	265.5	Hz	
			500	–	530.9	Hz	
			550	–	584	Hz	
			800	–	849.5	Hz	
			1000	–	1061.9	Hz	
			1500	–	1592.8	Hz	
			2000	–	2123.7	Hz	
t _{OSD}	Overall Signal Delay	VSUP	–	–	367	µs	2) Overall signal delay between sensor front-end and output. Transmission time of selected PWM frequency to be added. See Fig. 5–7. f _{decsel} = 8 kSps LP-Filter = off
t _{P_Init}	PWM Start-up Time	VSUP	–	–	9.5	ms	1) Initial start-up time until output is ready. 2 kHz PWM frequency Fig. 5–6 on page 33
t _{P_first_valid}	PWM Start-up Time till first Edge	VSUP	–	–	10	ms	1) Time until first valid rising/falling edge. Fig. 5–6 on page 33 2 kHz PWM frequency
OUT _{Res}	Output Resolution	VSUP	12	–	–	bit	
PMW _{DC}	PWM Duty-Cycle Range	VSUP	1	–	99	%	2)
PWM _{DCFM}	PWM Duty-Cycle in Failure Mode	VSUP	According registers PWM_STD_ERROR & MAG_LOSS_OUTPUT				1) Customer configurable
PWM _{DCUV}	PWM Duty-Cycle in case of Undervoltage	VSUP	–	2.0	–	%	1) Customer configurable. Alternatively same as PWM _{DCFM} .
PWM _{DCOV}	PWM Duty-Cycle in case of Overvoltage	VSUP	–	2.0	–	%	(see Table 3–3 on page 22) For V _{SUP} > V _{POR}
PWM _{DCMH}	PWM Duty-Cycle in case of Magnetic Field High Detection	VSUP	–	98.0	–	%	1) PWM freq. ≤ 1 kHz, C _{VSUP} =10nF
J _{PWM}	RMS PWM Jitter	VSUP	–	–	1.5	LSB ₁₃	1)
1) Characterized on small sample size, not tested							
2) Guaranteed by design							

Symbol	Parameter	Pin Name	Limit Values			Unit	Conditions
			Min.	Typ.	Max.		
SOIC8 Package							
R _{thja}	Thermal Resistance Junction to Air	–	–	–	140	K/W	³⁾ Determined with a 1S0P board
		–	–	–	93	K/W	³⁾ Determined with a 2S2P board
R _{thjc}	Thermal Resistance Junction to Case	–	–	–	33	K/W	³⁾ Determined with a 1S0P & 2S2P board
³⁾ Self-heating calculation see Section 6.1. on page 39							

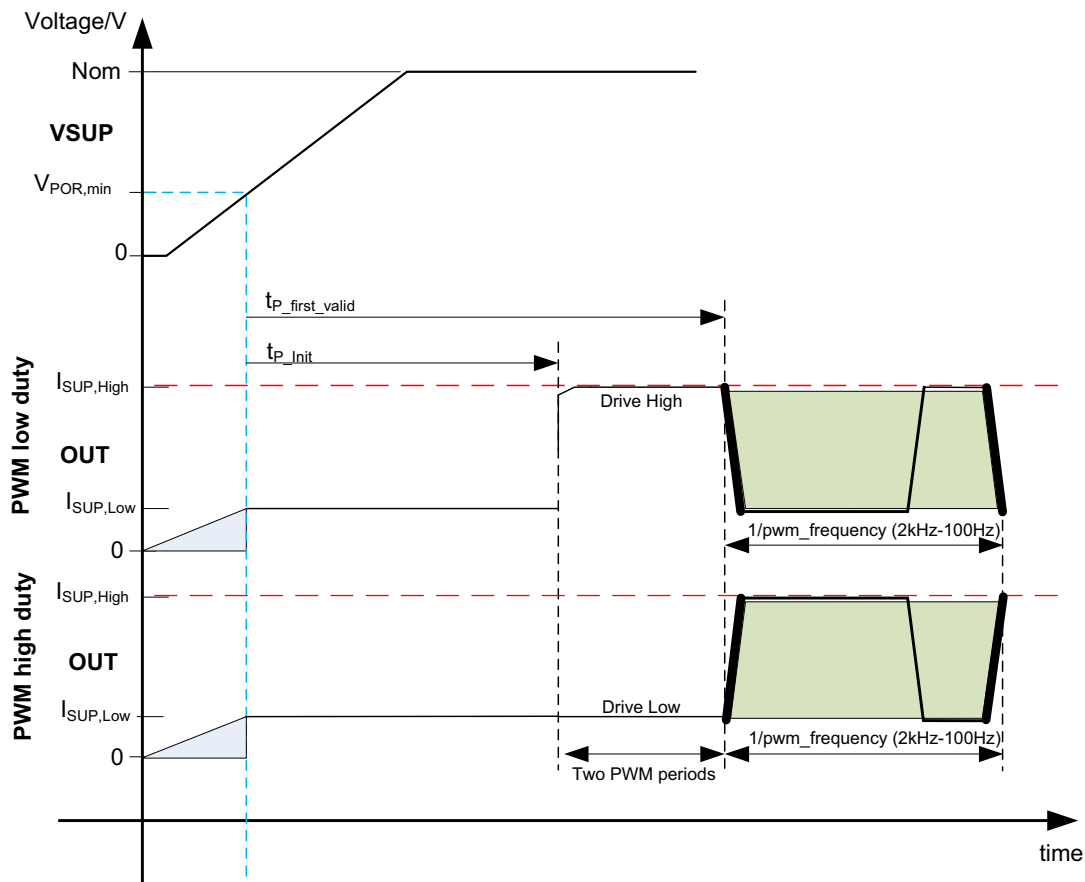

Fig. 5–6: Start-up behavior of HAL 3960

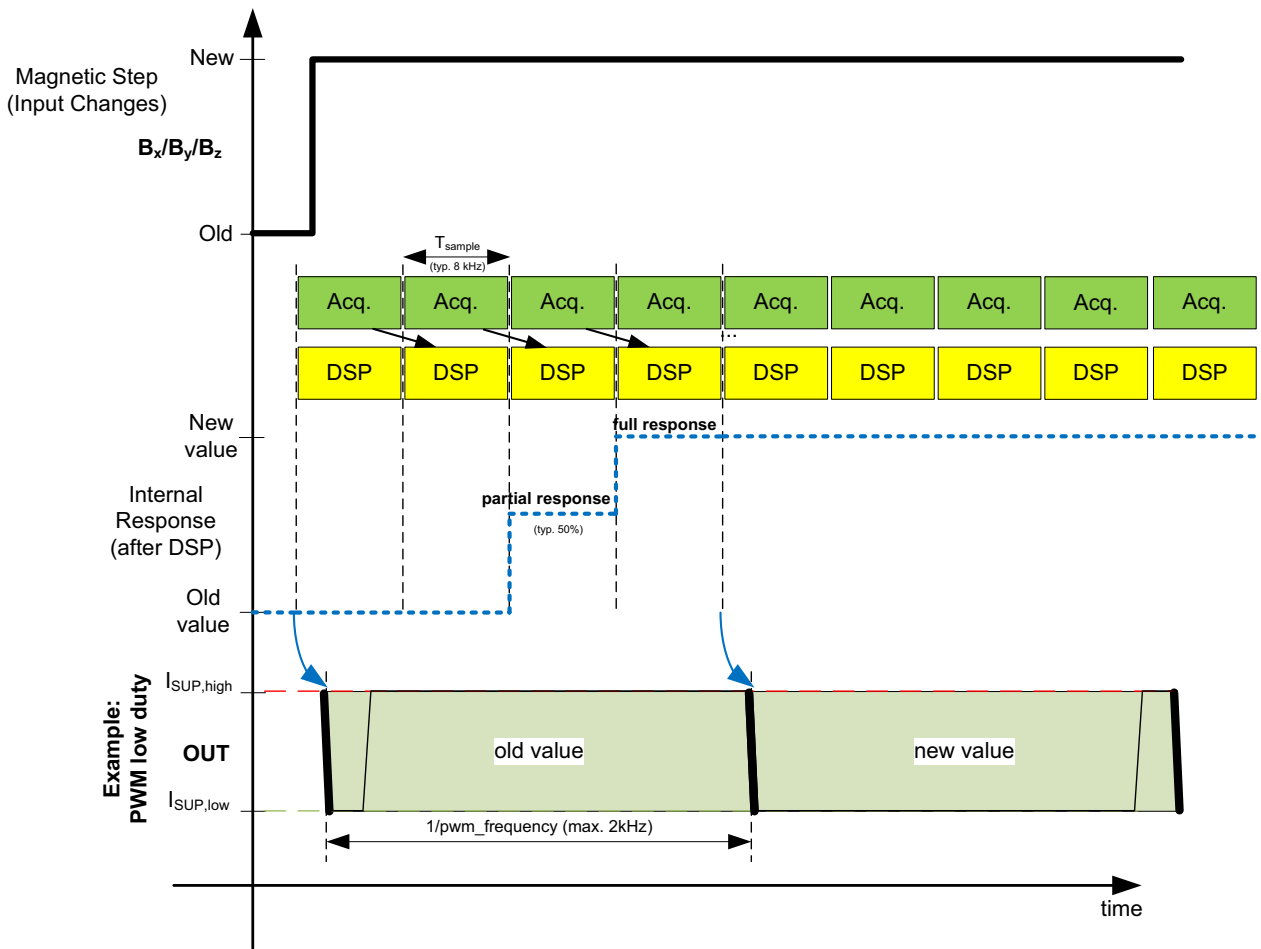

Fig. 5–7: Step response behavior of HAL 3960

5.10. Magnetic Characteristics

at $T_J = -40\text{ °C}$ to 155 °C , $V_{SUP} = 4.0\text{ V}$ to 11.0 V , $GND = 0\text{ V}$, after programming and locking of the sensor, at Recommended Operation Conditions if not otherwise specified in the column “Conditions”.

Typical Characteristics for $T_J = 25\text{ °C}$ and $V_{SUP} = 5.0\text{ V}$.

Symbol	Parameter	Pin Name	Min.	Typ.	Max.	Unit	Conditions
Rotary Setup with Stray-Field Compensation (Setup 1 & 2)							
ΔE_{otot}	Total Angular Error of Drifts	VSUP	-0.85	-	0.85	°	1) $B_{AMP} = \pm 10\text{ mT}$ Setup 2 (3 Z-Plates)
			-0.45	-	0.45	°	1) $B_{AMP} = \pm 10\text{ mT}$ Setup 1 (6 Z-Plates)
ΔE_{otemp}	Angular Error Drift over Temperature	VSUP	-0.5	-	0.5	°	1) $B_{AMP} = \pm 10\text{ mT}$
ΔE_{olife}	Angular Error Drift over Lifetime	VSUP	-0.45	-	0.45	°	1) $B_{AMP} = \pm 10\text{ mT}$ Setup 2 (3 Z-Plates) After 1008 h HTOL
			-0.2	-	0.2	°	1) $B_{AMP} = \pm 10\text{ mT}$ Setup 1 (6 Z-Plates) After 1008 h HTOL
E_{ohyst}	Angular Hysteresis Error	VSUP	-	-	0.05	°	2)
E_{onoise_1}	Angular Noise Setup 1	VSUP	-	0.13	0.23	°	3)
E_{onoise_2}	Angular Noise Setup 2	VSUP	-	0.19	0.33	°	3)
E_{oSF_1}	Angular Error due to Stray-Field for Setup 1	VSUP	-	-	0.1	°	1) 4) $B_{AMP} = \pm 10\text{ mT}$ wanted signal
E_{oSF_2}	Angular Error due to Stray-Field for Setup 2	VSUP	-	-	0.12	°	1) 4) $B_{AMP} = \pm 10\text{ mT}$ wanted signal
Linear Movement Setup (ΔXZ) with Stray-Field Compensation (Setup 3b)							
$SM_{\Delta XZ41}$	Sensitivity Mismatch between ΔX_{41} and ΔZ_{41} Channel	VSUP	-5	-	5	%	1) $T_A = 25\text{ °C}$
$Sense_{\Delta XZ41}$	Sensitivity of ΔX_{41} and ΔZ_{41} Channel	VSUP	121	128	135	LSB ₁₅ /mT	1) $T_A = 25\text{ °C}$
$\Delta SM_{\Delta XZ41}$	Thermal Sensitivity Mismatch Drift between ΔX_{41} and ΔZ_{41} Channel	VSUP	-2.5	-	2.5	%	1) Related to $T_A = 25\text{ °C}$
$Offset_{\Delta X41}$	Offset of ΔX_{41} Channel	VSUP	-30	-	30	LSB ₁₅	$T_A = 25\text{ °C}$
$Offset_{\Delta Z41}$	Offset of ΔZ_{41} Channel	VSUP	-15	-	15	LSB ₁₅	$T_A = 25\text{ °C}$
$\Delta Offset_{\Delta X41}$	Offset Drift of ΔX_{41} Channel	VSUP	-50	-	50	LSB ₁₅	Related to $T_A = 25\text{ °C}$
$\Delta Offset_{\Delta Z41}$	Offset Drift ΔZ_{41} Channel	VSUP	-15	-	15	LSB ₁₅	Related to $T_A = 25\text{ °C}$
All values are characterized on small sample size and 3-sigma values as long as not otherwise specified (not tested)							
1) Based on Simulation Model (not tested)							
2) Guaranteed by Design							
3) Characterized on small sample size, $B_{AMP} = \pm 10\text{ mT}$, $f_{dec sel} = 2\text{ kHz}$, Low-pass filter: off, 3-sigma values (not tested)							
4) Characterized on small sample size according to ISO 11452-8:2015, at 25 °C , with stray-field strength of 4 kA/m from X, Y and Z direction, 3-sigma values (not tested).							

Symbol	Parameter	Pin Name	Min.	Typ.	Max.	Unit	Conditions
$\Delta SM_{\Delta XZ41life}$	Relative Sensitivity Mismatch Drift between ΔX_{41} and ΔZ_{41} Channel over life time	VSUP	–	1.0	–	%	1) After 1008 h HTOL
$\Delta Offset_{\Delta X41life}$	Offset Drift of ΔX_{41} Channel over life time	VSUP	–	30	–	LSB ₁₅	After 1008 h HTOL
$\Delta Offset_{\Delta Z41life}$	Offset Drift of ΔZ_{41} Channel over life time	VSUP	–	5	–	LSB ₁₅	After 1008 h HTOL
$SF_{R\Delta X41}$	Stray-Field Rejection in ΔX_{41} Direction	VSUP	99	–	–	%	4) $T_A = 25^\circ C$
$SF_{R\Delta Z41}$	Stray-Field Rejection in ΔZ_{41} Direction	VSUP	99	–	–	%	4) $T_A = 25^\circ C$
$E_{\text{Ophase}\Delta XZ41}$	Phase Error between ΔX_{41} and ΔZ_{41} Channel	VSUP	–	± 2.2	–	°	between ΔX_{41} and ΔZ_{41} axis 1)
$E_{\Delta X41,noise}$	Digital Noise of ΔX_{41} Hall-Plates Channel	VSUP	–	2.4	–	LSB ₁₅	5)
$E_{\Delta Z41,noise}$	Digital Noise of ΔZ_{41} Hall-Plates Channel	VSUP	–	2.6	–	LSB ₁₅	5)
Off-Axis Rotary Setup (ΔXY) with Stray-Field Compensation (Setup 3a)							
$SM_{\Delta XY41}$	Sensitivity Mismatch between ΔX_{41} and ΔY_{41} Channel	VSUP	–2	–	2	%	1) $T_A = 25^\circ C$
$Sense_{\Delta XY41}$	Sensitivity of ΔX_{41} and ΔY_{41} Channel	VSUP	121	128	135	LSB ₁₅ /mT	1) $T_A = 25^\circ C$
$\Delta SM_{\Delta XY41}$	Thermal Sensitivity Mismatch Drift between ΔX_{41} and ΔY_{41} Channel	VSUP	–2.5	–	2.5	%	1) Related to $T_A = 25^\circ C$
$Offset_{\Delta XY41}$	Offset of ΔX_{41} and ΔY_{41} Channels	VSUP	–30	–	30	LSB ₁₅	$T_A = 25^\circ C$
$\Delta Offset_{\Delta XY41}$	Offset Drift of ΔX_{41} and ΔY_{41} Channels	VSUP	–50	–	50	LSB ₁₅	Related to $T_A = 25^\circ C$
$\Delta SM_{\Delta XY41life}$	Relative Sensitivity Mismatch Drift between ΔX_{41} and ΔY_{41} Channels over life time	VSUP	–	1.0	–	%	1) After 1008 h HTOL
$\Delta Offset_{\Delta XY41life}$	Offset Drift of ΔX_{41} and ΔY_{41} Channel over life time	VSUP	–	30	–	LSB ₁₅	After 1008 h HTOL
$SF_{R\Delta XY41}$	Stray-Field Rejection in ΔX_{41} and ΔY_{41} Direction	VSUP	99	–	–	%	
$E_{\text{Ophase}\Delta XY41}$	Phase Error between ΔX_{41} and ΔY_{41} Channel	VSUP	–	± 2.2	–	°	1) between ΔX_{41} and ΔY_{41} axis
$E_{\Delta XY41,noise}$	Digital Noise of ΔX_{41} and ΔY_{41} Hall-Plates Channel	VSUP	–	2.4	–	LSB ₁₅	5)
All values are characterized on small sample size and 3-sigma values as long as not otherwise specified (not tested)							
1) Based on Simulation Model (not tested)							
4) Characterized on small sample size according to ISO 11452-8:2015, at 25°C, with stray-field strength of 4 kA/m from X, Y and Z direction, 3-sigma values (not tested).							
5) Characterized on small sample size, 1-sigma values of COMP_CHx, fdecsel = 2 kHz, Low-pass filter: off (not tested)							

Symbol	Parameter	Pin Name	Min.	Typ.	Max.	Unit	Conditions
3D Measurement Setup without Stray-Field Compensation (Setup 4a)							
SM _{XYZ}	Sensitivity Mismatch between X or Y and Z Channel	VSUP	-4	-	4	%	T _A = 25 °C
SM _{XY}	Sensitivity Mismatch between X and Y Channel	VSUP	-2	-	2	%	T _A = 25 °C
Sense _{XYZ}	Sensitivity of X,Y and Z Hall-plate	VSUP	123	128	133	LSB ₁₅ /mT	T _A = 25 °C
ΔSM _{XYZ}	Thermal Sensitivity Mismatch Drift between X or Y and Z Hall Plates	VSUP	-2.5	-	2.5	%	Related to T _A = 25 °C
ΔSM _{XY}	Thermal Sensitivity Mismatch Drift between X and Y Hall Plates	VSUP	-2	-	2	%	Related to T _A = 25 °C
Offset _{XY}	Offset of X and Y Hall-plates	VSUP	-20	-	20	LSB ₁₅	T _A = 25 °C
Offset _Z	Offset of Z Hall-plate	VSUP	-12	-	12	LSB ₁₅	T _A = 25 °C
ΔOffset _{XY}	Offset Drift of X and Y Hall-plates	VSUP	-40	-	40	LSB ₁₅	Related to T _A = 25 °C
ΔOffset _Z	Offset Drift of Z Hall-plate	VSUP	-15	-	15	LSB ₁₅	Related to T _A = 25 °C
ΔSM _{XYZlife}	Relative Sensitivity Mismatch Drift between X, Y and Z Hall Plates over life time	VSUP	-	1.0	-	%	After 1008 h HTOL
ΔOffset _{XYlife}	Offset Drift of X and Y Hall-plates over life time	VSUP	-	30	-	LSB ₁₅	After 1008 h HTOL
ΔOffset _{Zlife}	Offset Drift of Z Hall-plate over life time	VSUP	-	5	-	LSB ₁₅	After 1008 h HTOL
E _{ophaseXYZ}	Phase Error between X, Y and Z Hall-Plates	VSUP	-	±1.6	-	°	XY axis
			-	±1.6	-	°	XZ axis
			-	±1.6	-	°	YZ axis
E _{XYZ,noise}	Digital Noise of X, Y or Z Hall-Plates Channel	VSUP	-	2.2	-	LSB ₁₅	⁵⁾
2D Measurement Setup (virtual centered Pixel XY) without Stray-Field Compensation (Setup 4b)							
SM _{ΣXY41}	Sensitivity Mismatch between ΣX ₄₁ and ΣY ₄₁ Channel	VSUP	-3	-	3	%	T _A = 25 °C
Sense _{ΣXY41}	Sensitivity of ΣX ₄₁ and ΣY ₄₁ Channel	VSUP	121	128	135	LSB/mT	T _A = 25 °C
ΔSM _{ΣXY41}	Thermal Sensitivity Mismatch Drift between ΣX ₄₁ and ΣY ₄₁ Channel	VSUP	-2	-	2	%	Related to T _A = 25 °C
Offset _{ΣXY41}	Offset of ΣX ₄₁ and ΣY ₄₁ Channel	VSUP	-25	-	25	LSB ₁₅	T _A = 25 °C
ΔOffset _{ΣXY41}	Offset Drift of ΣX ₄₁ and ΣY ₄₁ Channel	VSUP	-40	-	40	LSB ₁₅	Related to T _A = 25 °C
ΔSM _{ΣXY41life}	Relative Sensitivity Mismatch Drift between ΣX ₄₁ and ΣY ₄₁ Channel over life time	VSUP	-	1.0	-	%	After 1008 h HTOL
All values are characterized on small sample size and 3-sigma values as long as not otherwise specified (not tested)							
⁵⁾ Characterized on small sample size, 1-sigma values of COMP_CHx, fdecsel = 2 kHz, Low-pass filter: off (not tested)							

Symbol	Parameter	Pin Name	Min.	Typ.	Max.	Unit	Conditions
$\Delta\text{Offset}_{\Sigma XY41\text{life}}$	Offset Drift of ΣX_{41} and ΣY_{41} Channel over Life Time	VSUP	–	30	–	LSB ₁₅	After 1008 h HTOL
$E_{\text{phase}\Sigma XY41}$	Phase Error between ΣX_{41} and ΣY_{41}	VSUP	–	± 2.2	–	°	1)
$E_{\Sigma XY41,\text{noise}}$	Digital Noise of ΣX_{41} and ΣY_{41} Hall-Plates Channel	VSUP	–	1.9	–	LSB ₁₅	5)
All values are characterized on small sample size and 3-sigma values as long as not otherwise specified (not tested)							
1) Based on Simulation Model (not tested)							
5) Characterized on small sample size, 1-sigma values of COMP_CHx, fdecsel = 2 kHz, Low-pass filter: off (not tested)							

5.11. Temperature Sensor

at $T_J = -40\text{ °C}$ to 155 °C , $V_{\text{SUP}} = 4.0\text{ V}$ to 11.0 V , $\text{GND} = 0\text{ V}$, after programming and locking of the sensor, at Recommended Operation Conditions if not otherwise specified in the column “Conditions”.

Typical Characteristics for $T_J = 25\text{ °C}$ and $V_{\text{SUP}} = 5.0\text{ V}$.

Symbol	Parameter	Pin No.	Min.	Typ.	Max.	Unit	Conditions
$\text{TADJ}_{\text{Gain}}$	Gain of Temperature Sensor	VSUP	–	89.25	–	LSB ₁₅ / °C	1) for TADJ register
$\text{TADJ}_{\text{Offset}}$	Temperature Sensor Offset	VSUP	–	3720	–	LSB ₁₅	1) for TADJ register
1) Not tested							

6. Application Notes

6.1. Ambient Temperature

Due to the internal power dissipation, the temperature on the silicon chip (junction temperature T_J) is higher than the temperature outside the package (ambient temperature T_A).

$$T_J = T_A + \Delta T$$

The maximum ambient temperature is a function of power dissipation, maximum allowable die temperature and junction to ambient thermal resistance (R_{thja}). With a typical supply voltage of 5.0 V the power dissipation P is 0.15 W. The junction to ambient thermal resistance R_{thja} is specified in Section 5.9. on page 31.

The difference between junction and ambient air temperature is expressed by the following equation (at static conditions and continuous operation):

$$\Delta T = P * R_{thjX}$$

The X represents junction to air, case or solder point.

For worst-case calculation, use the max. parameters for I_{SUP} and R_{thjX} , and the max. value for V_{SUP} from the application.

Note The calculated self-heating of the device is only valid for the R_{th} test boards. Depending on the application setup the final results in an application environment might deviate from these values.

6.2. EMC and ESD

Please contact TDK-Micronas for detailed information on EMC and ESD performance.

6.3. Application Circuit for HAL 3960

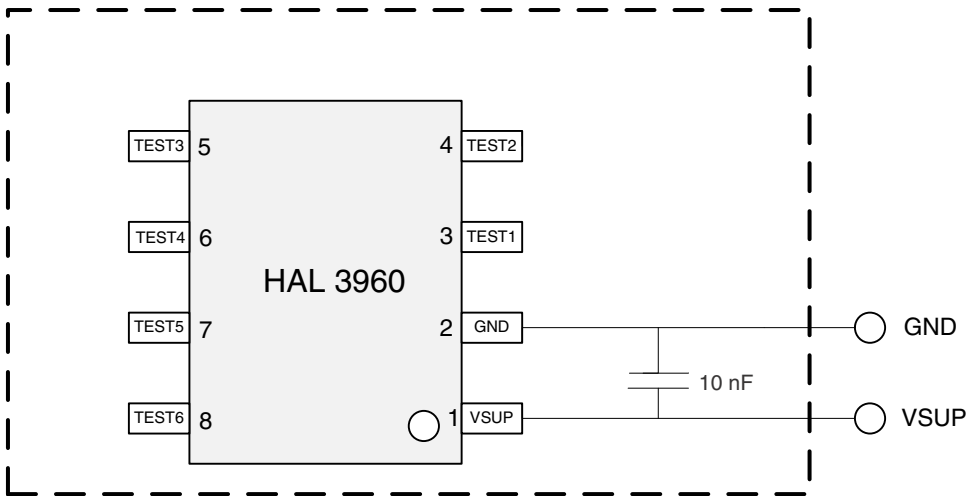

Fig. 6–1: Recommended application circuit for HAL 3960

6.4. Recommended Pad Size SOIC8 Package

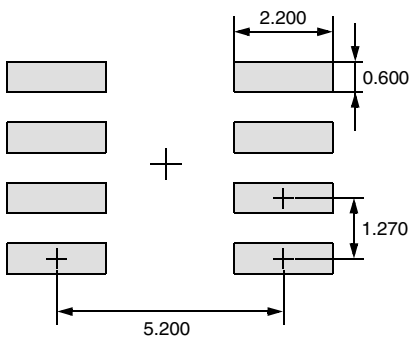

Fig. 6–2: Pad size recommendation for SOIC8 Package (all dimensions in mm)

7. Programming of the Sensor

HAL 3960 features two different customer modes. In **Application Mode** the sensor provides a PWM signal. In **Programming Mode (Listen Mode)** it is possible to change the register settings of the sensor.

After power-up the sensor is always operating in the **Application Mode**. It is switched to the **Programming Mode** by a BiPhase-M protocol via supply voltage modulation. Therefore, the programming device needs to provide a long sync pulse at the supply pin.

7.1. Programming Interface

In Programming Mode HAL 3960 is addressed by modulating a serial telegram on the sensor's supply pin. The sensor answers with a modulation of the supply current.

A logical "0" is coded as no level change within the bit time. A logical "1" is coded as a level change of typically 50 % of the bit time. After each bit, a level change occurs (see Fig. 7–1).

The serial telegram is used to transmit the memory content, error codes and digital values of the angle information from and to the sensor.

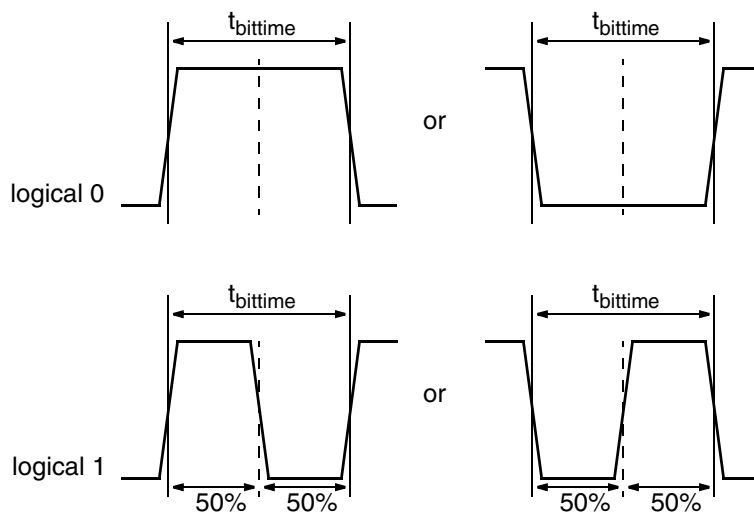

Fig. 7–1: Definition of logical 0 and 1 bit

Table 7–1: Telegram parameters for the Host (All voltages are referenced to GND.)

Symbol	Parameter	Pin No.	Limit Values			Unit	Test Conditions
			Min.	Typ.	Max.		
V _{SUPL}	Voltage for Supply Low Level during Communication	VSUP	4.5	5.0	6.0	V	
V _{SUPH}	Voltage for Supply High Level during Communication	VSUP	7.5	8.0	8.5	V	
I _{SUPL}	Sensor Supply Current Low Level during Communication	VSUP	11	13	15	mA	
I _{SUPH}	Sensor Supply Current High Level during Communication	VSUP	22	26	30	mA	

7.2. Programming Environment and Tools

For the programming of HAL 3960 during product development a programming tool including hardware and software is available on request. It is recommended to use the TDK-Micronas tool kit (TDK MSP V1.x and LabView Programming Environment) in order to facilitate the product development. The details of programming sequences are content of the document “HAL 3960, HAL/HAC 3980 Programming Guide”.

7.3. Programming Information

For production and qualification tests, it is mandatory to set the LOCK bit to one after final adjustment and programming of HAL 3960.

Before locking the device, it is recommended to read back all register values to ensure that the intended data is correctly stored in the sensor’s memory. Alternatively, it is also possible to cross-check the sensor output signal with the intended output behavior.

The success of the LOCK process shall be checked by reading the status of the LOCK bit after locking.

Even after locking the device it is still possible to read the memory content.

It is also mandatory to check the acknowledge of the sensor after each write and store sequence to verify if the programming of the sensor was successful.

Electro-Static Discharges (ESD) may disturb the programming pulses. Please take precautions against ESD.

Note A description of the communication protocol and the programming of the sensor is available in the separate document “HAL 3960, HAL/HAC 3980 Programming Guide”.

8. Document History

1. Data Sheet: "HAL 3960 Stray-Field Robust 2D Position Sensor with 2-wire PWM Interface", May 5, 2022, AI000219_001EN. First release of the Data Sheet.
Describing ROM_ID release: 2300 (mass production release)