

XGZG360 CO2 SENSOR

FEATURES

- 1) MEMS Thermopile element
- 2) TO-46 Package
- 3) High sensitivity
- 4) 4.26 μ m Narrow band Filter
- 5) High accuracy NTC

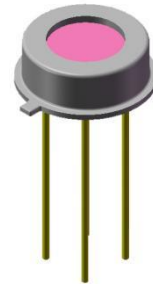

APPLICATIONS

- 1) NDIR CO2 Gas detector
- 2) Indoor, outdoor air quality monitor.
- 3) HVAC System, Air conditioner etc.,
- 4) Other medical, Agricultural, IoT, Environmental protection etc. field.

PERFORMANCE SPECS

Parameter	Value	Unit	Conditions
Chip size	1.93 X 1.93	mm	
Sensitive area	1.1 X 1.1	mm	
Field of view	80	o	At 50 % intensity points
Thermopile resistance	50 \pm 5%	k Ω	temp=25 $^{\circ}$ C
Noise voltage	28.8	nV/Hz ^{1/2}	temp=25 $^{\circ}$ C
Responsivity	9690	mV/W	500K(5.5 μ m, long pass)
Temp. Coefficient of resistance	0.255	%/ $^{\circ}$ C	temp=25 $^{\circ}$ C - 75 $^{\circ}$ C
Time constant	25	ms	
Specific detectivity	2.1E08	cmHz ^{1/2} /W	500K, 1Hz
NCT	100 \pm 1%	K Ω	25 $^{\circ}$ C
Thermistor BETA-value	3950 \pm 1%	K	25 $^{\circ}$ C/50 $^{\circ}$ C

ABSOLUTE MAXIMUM RATINGS

Parameter	Value	Unit
Operating temperature	-20 to +100	°C
Storage Temperature	-40 to +125	°C

OPTICAL CURVES

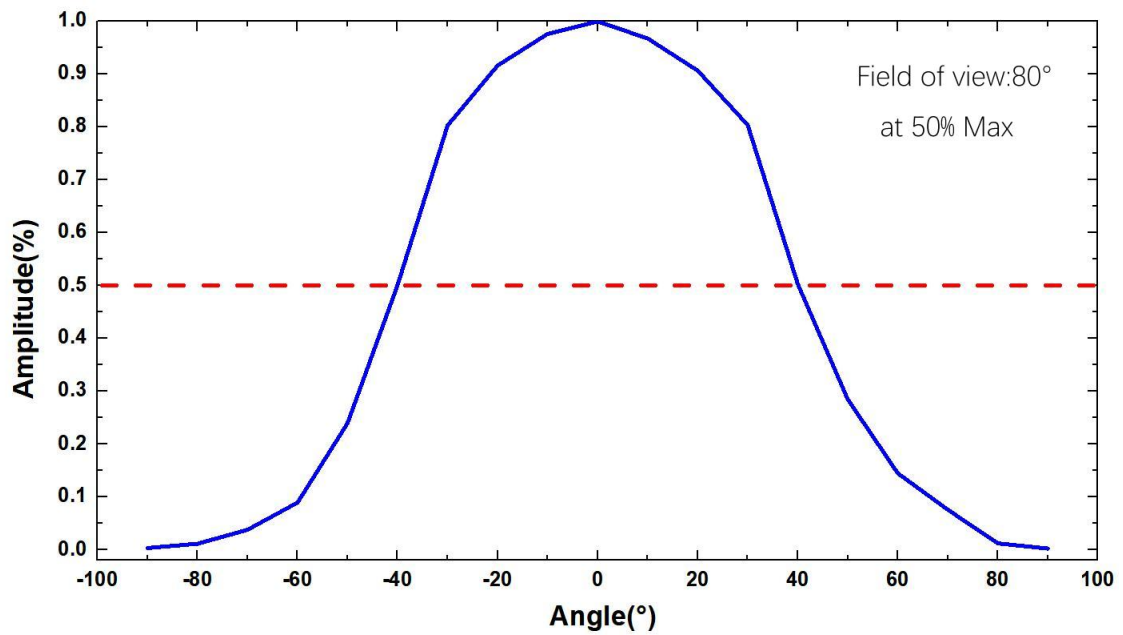

IR CHARACTERISTICS

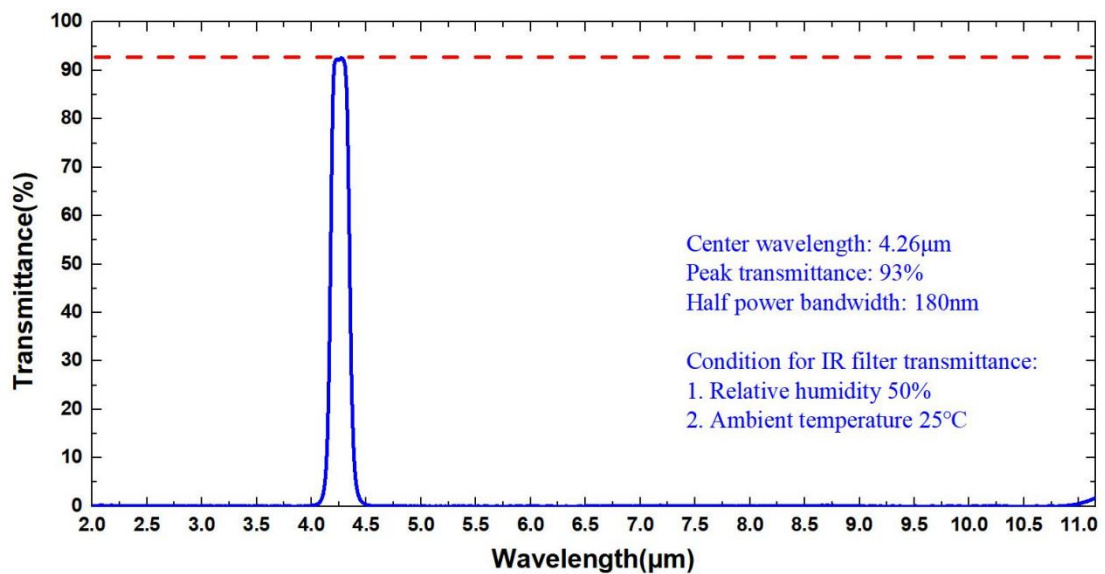

MECHANICAL DIMENSION

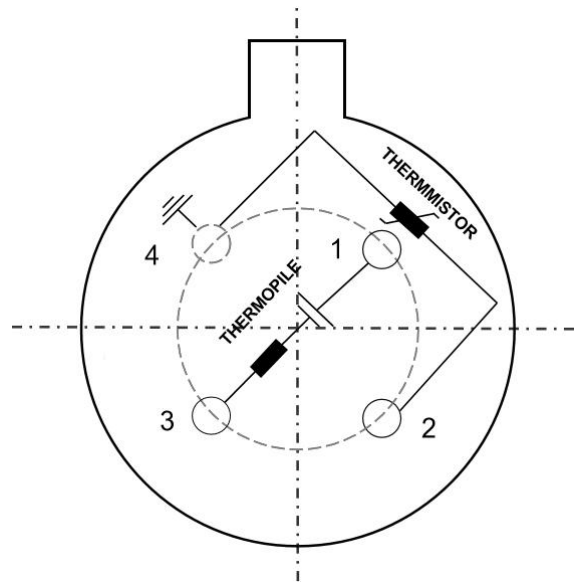
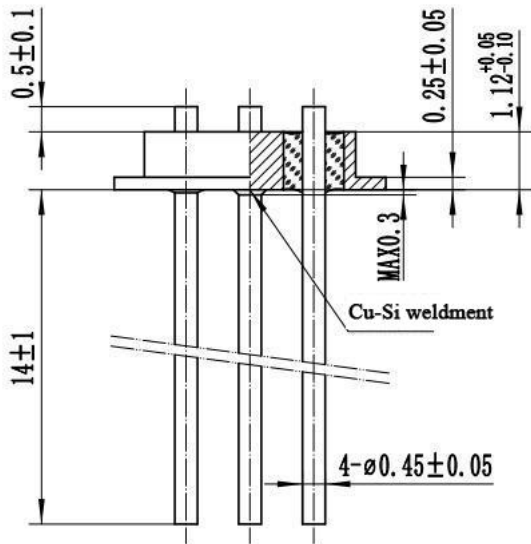
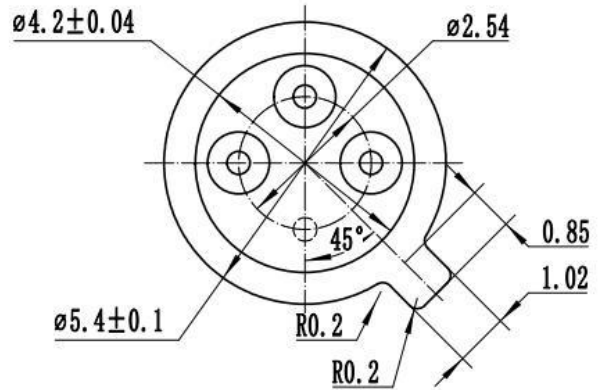
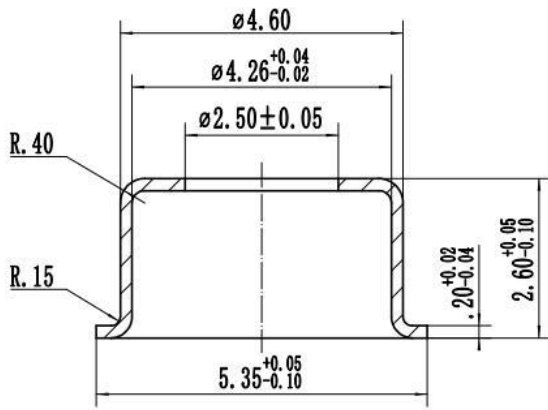

ELECTRICAL CONNECTIONS

Pin	1	2	3	4
Define	Thermopile+	NTC	Thermopile-	GND

【 SAFETY NOTES 】

Using these sensors products may malfunction due to external interference and surges, therefore, please confirm the performance and quality in actual use. Just in case, please make a safety design on the device (fuse, circuit breaker, such as the installation of protection circuits, multiple devices, etc.), so it would not harm life, body, property, etc even a malfunction occurs.

To prevent injuries and accidents, please be sure to observe the following items:

- The driving current and voltage should be used below the rated value.
- Please follow the terminal connection diagram for wiring. Especially for the reverse connection of the power supply, it will cause an accident due to circuit damage such as heat, smoke, fire, etc.
- In order to ensure safety, especially for important uses, please be sure to consider double safety circuit configuration.
- Do not apply pressure above the maximum applied pressure. In addition, please be careful not to mix foreign matter into the pressure medium. Otherwise, the sensor will be discarded, or the media will blow out and cause an accident.
- Be careful when fixing the product and connecting the pressure inlet. Otherwise, accidents may occur due to sensor scattering and the blowing out of the media.
- Because the sensor PIN is sharp, please be careful not to hurt your body when using it.

【 WARRANTY 】

The information in this sheet has been carefully reviewed and is believed to be accurate; however, no responsibility is assumed for inaccuracies. Furthermore, this information does not convey to the purchaser of such devices any license under the patent rights to the manufacturer. CFSensor reserves the right to make changes without further notice to any product herein. CFSensor makes no warranty, representation or guarantee regarding the suitability of its product for any particular purpose, nor does CFSensor assume any liability arising out of the application or use of any product or circuit and specifically disclaims any and all liability, including without limitation consequential or incidental damages. Typical parameters can and do vary in different applications. All operating parameters must be validated for each customer application by customer's technical experts. CFSensor does not convey any license under its patent rights nor the rights of others.

【 CONTACT 】

CFSensor

22F/14Bldg High-Tech Park High-Tech Area Wuhu P.R.C.241000

Tel/Fax: +86 18226771331 Email: INFO@CFSensor.com

Appendix

Temperature vs. Resistance of NTC

Temp. (°C)	R_Cent (Kohm)	Temp. (°C)	R_Cent (Kohm)	Temp. (°C)	R_Cent (Kohm)	Temp. (°C)	R_Cent (Kohm)
-40	3225.545	1	308.903	42	49.073	83	11.21
-39	3023.332	2	293.781	43	47.155	84	10.853
-38	2834.987	3	279.483	44	45.321	85	10.509
-37	2659.483	4	265.958	45	43.569	86	10.177
-36	2495.874	5	253.161	46	41.892	87	9.858
-35	2343.289	6	241.049	47	40.289	88	9.55
-34	2200.924	7	229.582	48	38.755	89	9.253
-33	2068.041	8	218.722	49	37.286	90	8.967
-32	1943.955	9	208.435	50	35.881	91	8.691
-31	1828.036	10	198.687	51	34.536	92	8.424
-30	1719.704	11	189.447	52	33.248	93	8.167
-29	1618.419	12	180.686	53	32.014	94	7.919
-28	1523.686	13	172.377	54	30.832	95	7.68
-27	1435.046	14	164.495	55	29.699	96	7.449
-26	1352.073	15	157.015	56	28.614	97	7.226
-25	1274.376	16	149.914	57	27.573	98	7.01
-24	1201.590	17	143.173	58	26.576	99	6.802
-23	1133.379	18	136.770	59	25.619	100	6.601
-22	1069.430	19	130.688	60	24.701	101	6.407
-21	1009.455	20	124.908	61	23.821	102	6.22
-20	953.185	21	119.413	62	22.976	103	6.039
-19	900.373	22	114.190	63	22.166	104	5.864
-18	850.787	23	109.222	64	21.388	105	5.694
-17	804.212	24	104.497	65	20.641	106	5.531
-16	760.451	25	100.000	66	19.923	107	5.373
-15	719.319	26	95.720	67	19.234	108	5.22
-14	680.643	27	91.646	68	18.572	109	5.072
-13	644.265	28	87.766	69	17.936	110	4.929
-12	610.035	29	84.071	70	17.325	111	4.79
-11	577.816	30	80.550	71	16.738	112	4.656
-10	547.478	31	77.195	72	16.173	113	4.527
-9	518.903	32	73.997	73	15.630	114	4.401
-8	491.979	33	70.947	74	15.108	115	4.28
-7	466.601	34	68.039	75	14.605	116	4.162
-6	442.674	35	65.265	76	14.122	117	4.048
-5	420.105	36	62.618	77	13.657	118	3.938
-4	398.813	37	60.092	78	13.209	119	3.831
-3	378.717	38	57.681	79	12.779	120	3.728
-2	359.744	39	55.379	80	12.364	121	3.628
-1	341.826	40	53.180	81	11.965	122	3.531
0	324.899	41	51.080	82	11.580	123	3.437