

# Infrared LED Particle Sensor PM1003PH



## Introduction

Infrared LED particle sensor module PM1003PH adopts the principle of optical scattering to detect the variation trend of particle (size between 1 $\mu$ m to 10 $\mu$ m) concentration in the air. There is an infrared light-emitting diode and an optoelectronic sensor built-in PM1003PH, and light rays from the light-emitting diode will be reflected when pass through the particle. The optoelectronic sensor can show the concentration of particle in the air by detecting the intensity of reflected light. Sensor can output particle mass concentration by PWM or UART signal.

## Advantages

The sensor has the leading detection stability among the infrared LED particle sensor in the market and can decrease the interference of outside environment through the electromagnetic screen design.

The filter circuit and MCU software program of the sensor is designed to filter out noise signals so that the data output is more stable and reliable.

## Principle

According to the scattering principle of light, The LED light generates reflected light when meet particles. Photoelectric diode detects the light intensity of reflected light, judging the particle concentration according to pulse signal.

Photoelectric diode will output low pulse when do not detect particles. Otherwise, photoelectric diode will output high pulse when detect particles. And pulse signal is in proportion on the detected light intensity. Pulse signal will be magnified by amplifier and calculated by CPU, output measuring result finally.

## Features

- ✧ PWM output(Low level pulse width output)
- ✧ Low level pulse width is proportional to dust concentration
- ✧ Electromagnetic shielding, anti-interference
- ✧ High stability and good consistency

## Applications

- ✧ Air purifier
- ✧ Residential and commercial air conditioning
- ✧ HVAC system
- ✧ Desktop IAQ monitor
- ✧ Environmental monitoring equipment
- ✧ IoT hardware intelligence

**Table 1. Specification**

LED particle sensor specification	
<b>Principle</b>	Light scattering(LED)
<b>Measuring range</b>	0~500 $\mu$ g/m <sup>3</sup>
<b>Accuracy</b>	$\leq 100\mu\text{g}/\text{m}^3$ : $\pm 30\mu\text{g}/\text{m}^3$ $> 100\mu\text{g}/\text{m}^3$ : $\pm 30\%$ (GRIMM as reference instruments, 25 $\pm$ 2 $^{\circ}$ C, 50% $\pm$ 10%RH)
<b>Time to first reading</b>	60s
<b>Working condition</b>	-10 $^{\circ}$ C~+50 $^{\circ}$ C, 0~95%RH(non-condensing)
<b>Storage condition</b>	-20 $^{\circ}$ C~+60 $^{\circ}$ C, 0~ 95%RH(non-condensing)
<b>Working voltage</b>	DC 5V $\pm$ 10% ripple <50mV
<b>Working current</b>	$\leq 90$ mA
<b>Signal output</b>	UART 4.5V level, PWM 4.5V level
<b>Size</b>	W59*H45*D20 mm
<b>Lifetime</b>	$\geq 5$ year

## Internal architecture and principle description

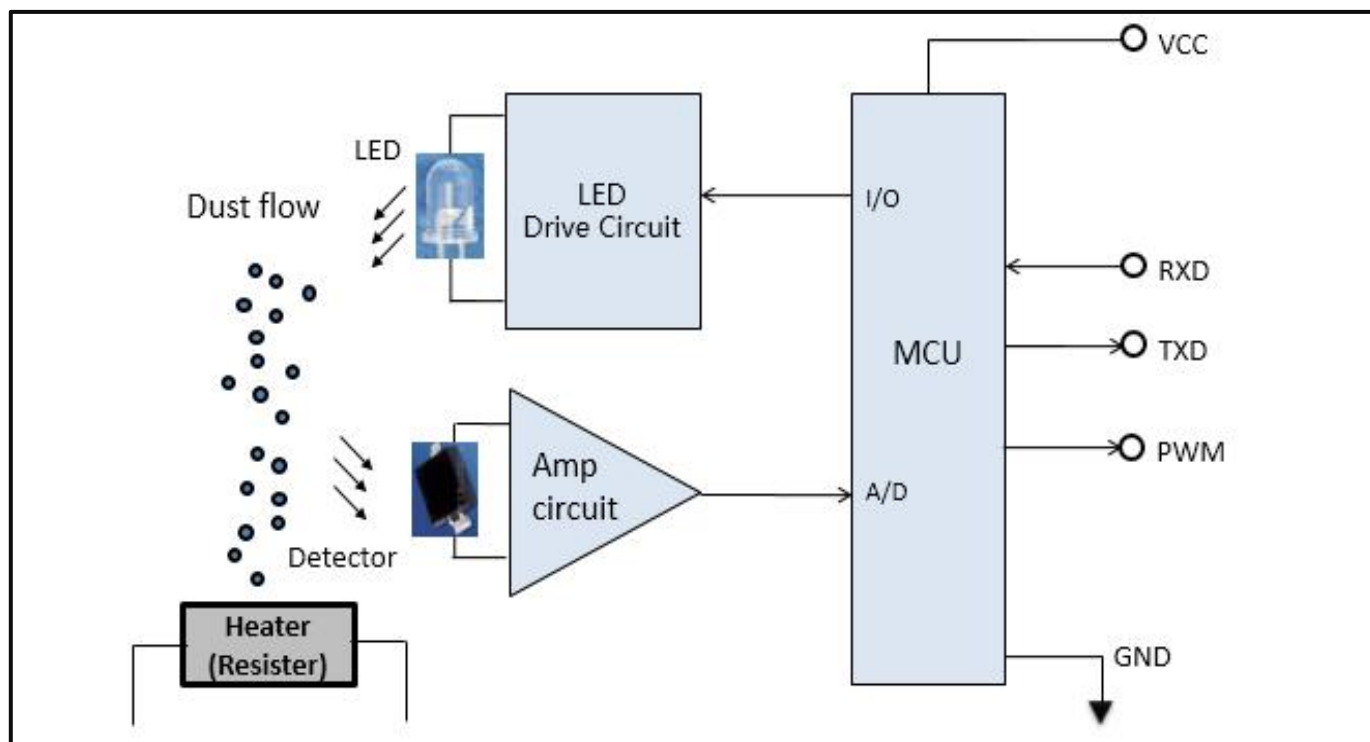

**Fig 1** Interior configuration

According to the above picture, the light source of PM1003PH is consist of LED which launch to detecting particles light, front-loading lens and drive circuit. The detecting part is consist of light sensitive part and amplifying circuit.

### The particle measuring principle of PM1003PH

When heating resistor heats, and after showing updraft, particles will pass the detecting chamber. The LED light will be scattered by particles and will be figured out by light sensitive equipment, then convert into electronic signal. Electronic signal is disposed by filter circuit and MCU, it will convert into PWM signal output.

## I/O definitions and connectors

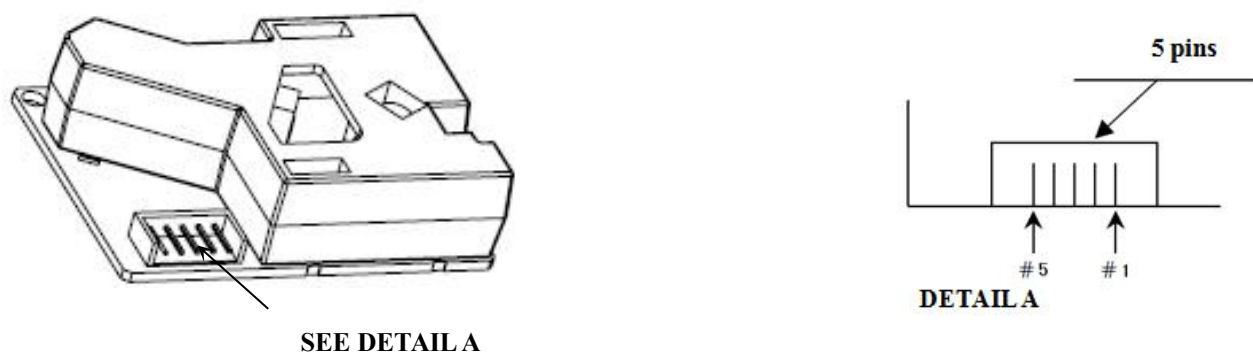

**Fig 2** Connector Dimensions

**Table 2. I/O definitions**

No.	Pin	Description
1	GND	Power input (ground terminal)
2	TX	UART-TX output (TTL level@4.5V)
3	+5V	Power input (+5V)
4	P1	Pulse width output
5	RX	UART-RX input(TTL level@4.5V)

**Table 3.Connector description**

Item	Pin space
EH-5	2.5mm pitch

## Photoelectric linear

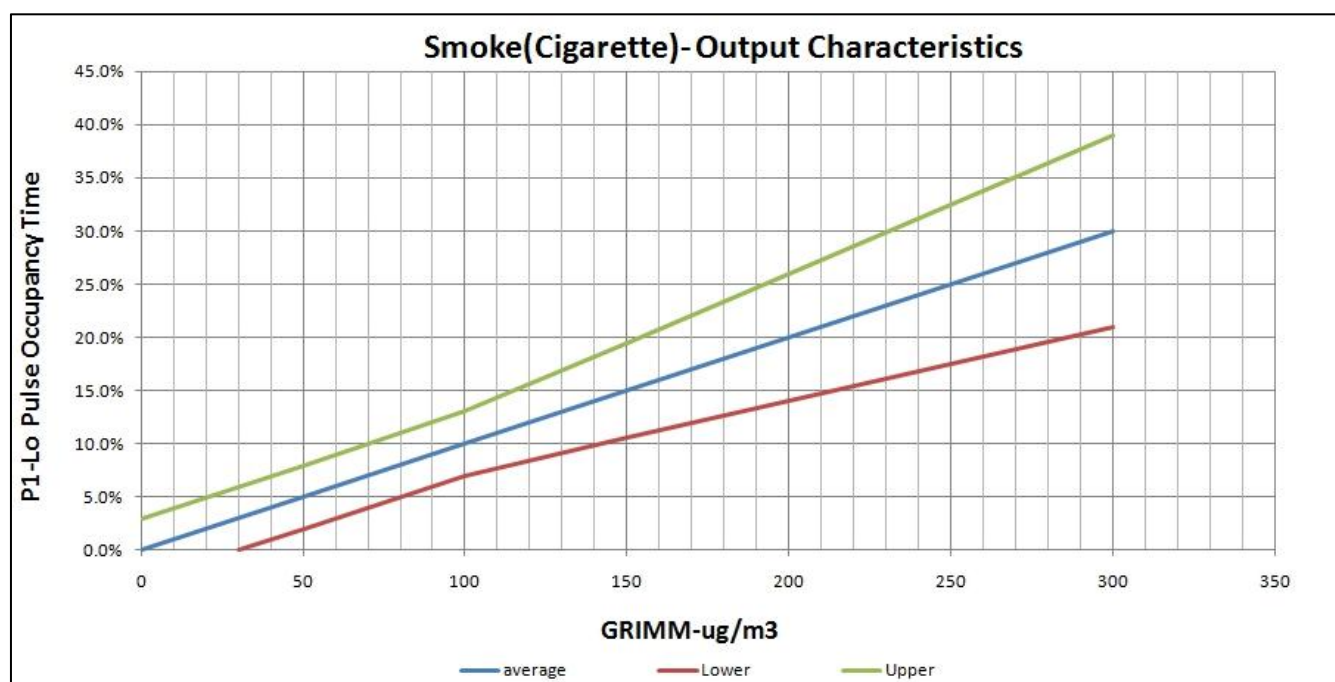

**Fig 3** Sensor linear curve

◆ The linear curve of the sensor is verified in the following conditions:

The temperature of the environment is  $25\pm 2^{\circ}\text{C}$

The humidity of the environment is  $50\pm 10\%\text{RH}$

Cigarette smoke: Hong Ta Shan 8mg

Test chamber:  $30\text{m}^3$

## Communication protocol

---

### ◆ PWM communication:

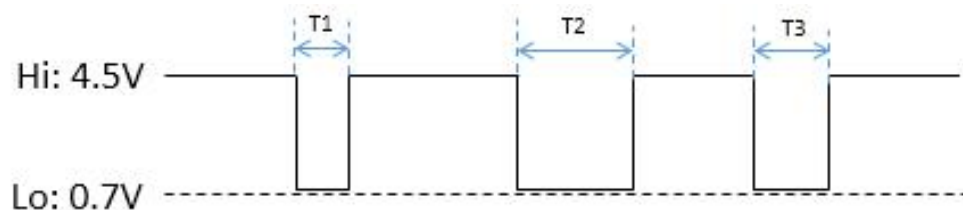

### PWM communication description:

- Pulse width: 1ms~1000ms
- Low level duty ratio: low pulse time  $T_1+T_2+T_3+\dots+T_n$ /PWM cycle  $T_0(30s)(\%)$
- The sensor will output PWM signal after powered on

### ◆ UART communication

#### UART level range

- UART RX: 0~4.5V data input
- UART TX: 0~4.5V data output

#### UART configuration

- Data bit: 8
- Stop bit: 1
- Parity bit: no
- Baud rate: 9600bps

### ◆ Read measuring result of particles:

Send: 11 02 0B 01 E1

Response: 16 11 0B DF1-DF4 DF5-DF8 DF9-DF12 DF13 DF14 DF15 DF16[CS]

Description: The value(n) =  $DF_3 * 256 + DF_4$

Note: DF1-DF2 is reserved, DF5-DF16 is reserved

(n=PWM duty ratio \* 1000, It is the average of the 70s)

The UART output value is equivalent to the average value of the 70s after the PWM output value's duty ratio \* 1000.

## Dimensions

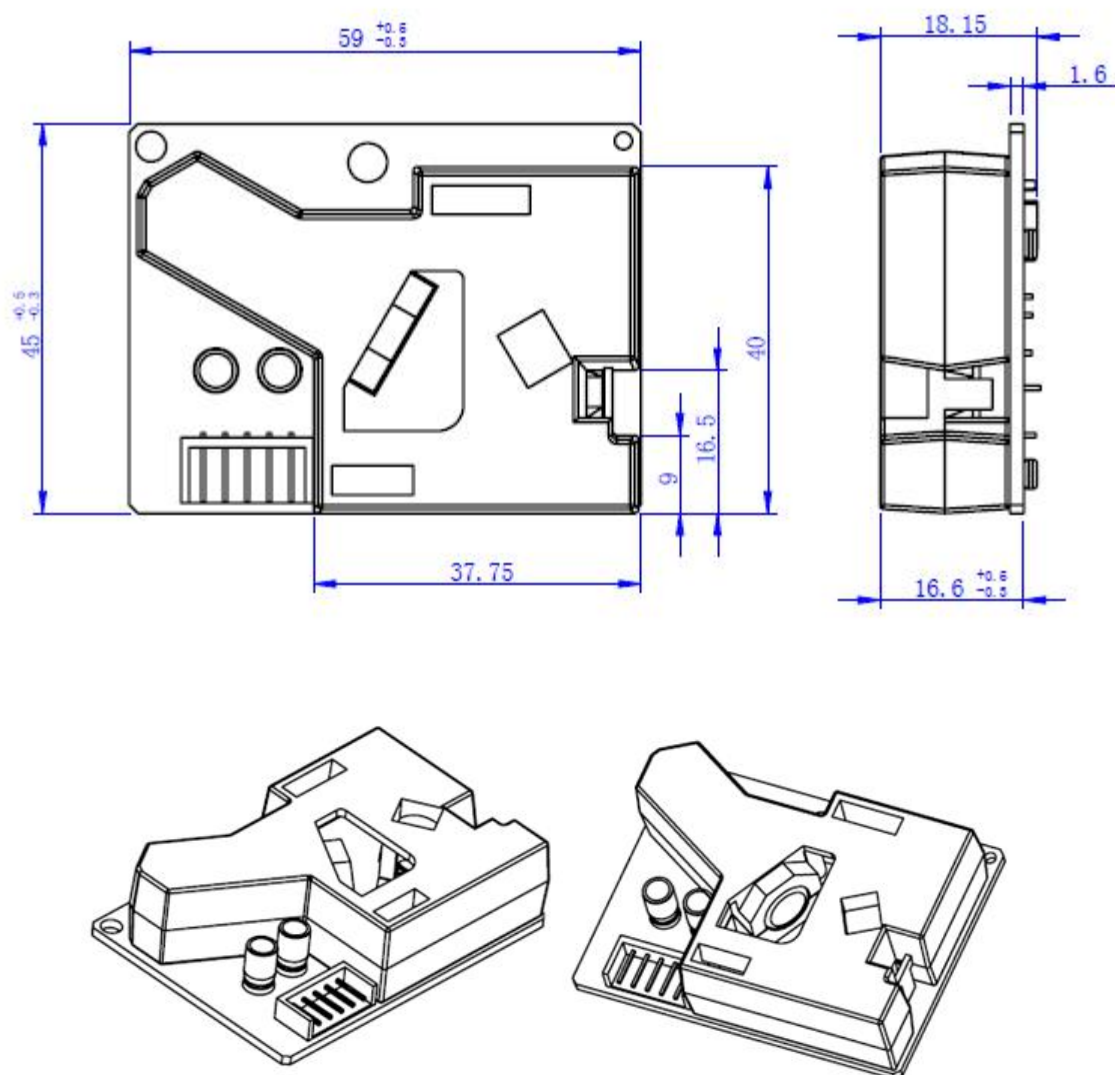

**Figure4 Dimensions (Unit: mm, tolerances:  $\pm 0.2$ mm)**

## Reliability test

Test Item	Test Condition	Standard	Sample qty: N Defective qty: C
Low temperature storage	In the ambient of $-20^{\circ}\text{C}\pm 2^{\circ}\text{C}$ , keep for 500H without powering on. Measure the error in normal temperature condition.	The sensor works normally after 2 hours in normal temperature condition	N=10, C=0
High temperature storage	In the ambient of $60^{\circ}\text{C}\pm 2^{\circ}\text{C}$ , and keep for 500H without powering on. Measure the error in normal temperature condition.	The sensor works normally after 2 hours in normal temperature condition	N=10, C=0
Low temperature working	Leave the sensor in the ambient of $-10\pm 2^{\circ}\text{C}$ , max voltage (within range of acceptable working voltage), work for 500H. Measure the error in normal temperature condition.	The sensor works normally after 2 hours in normal temperature condition	N=10, C=0
High temperature working	Leave the sensor in the ambient of $50\pm 2^{\circ}\text{C}$ max voltage (within range of acceptable working voltage), work for 500H. Measure the error in normal temperature condition	The sensor works normally after 2 hours in normal temperature condition	N=10, C=0
Impact	Leave the sensor in ambient of $-20^{\circ}\text{C} \pm 2^{\circ}\text{C}$ for 60 minutes, then move it to ambient of $+60^{\circ}\text{C} \pm 2^{\circ}\text{C}$ within 10s for 60 minutes. Regard this as a cycle, and totally 10 cycles. The sensor is powered off during the test	The sensor works normally after 2 hours in normal temperature condition	N=5, C=0
High temperature and high humidity working	Operating the sensor in the ambient of $40\pm 2^{\circ}\text{C}$ , 90~95%RH, max voltage (within range of acceptable working voltage), for 21days.	The sensor works normally after 2 hours in normal temperature condition	n=10 c=0
Salt spray test	According to GB/T2423.17-2008, leave the sensor in the $35^{\circ}\text{C}$ salt-fog cabinet, spray it with 5% sodium chloride saltwater for 24 hours. Clean the sensor after test.	No red rust on the sensor surface.	n=2 c=0
Thermal cycle	Leave the sensor in ambient of $-20^{\circ}\text{C}\pm 2^{\circ}\text{C}$ for 60mins then move it to ambient of $+60^{\circ}\text{C}\pm 2^{\circ}\text{C}$ for 60mins. Keep this cycle for 10 times. The sensor is powered off during the test.	The sensor works normally after over 1 hour and less than 2 hours in the ambient. No corrosion, no breaking in appearance	n=5 c=0
Vibration test	Naked, 5-55-5Hz/min, with amplitude of 1.5mm, vibrate in X, Y, Z direction, each direction for 2 hours.	The sensor works normally after 2 hours in the ambient.	n=4 c=0
Packaging drop test	Height of fall: Set the corresponding height of the weight in accordance with GB/T 4857.18. Test according to GB/T4857.5 packaging transport package drop test method. The drop test sequence is one corner, three edges and six sides	No breaking in appearance, No components drop off, the sensor works normally	n=1 c=0

## Ordering information

---

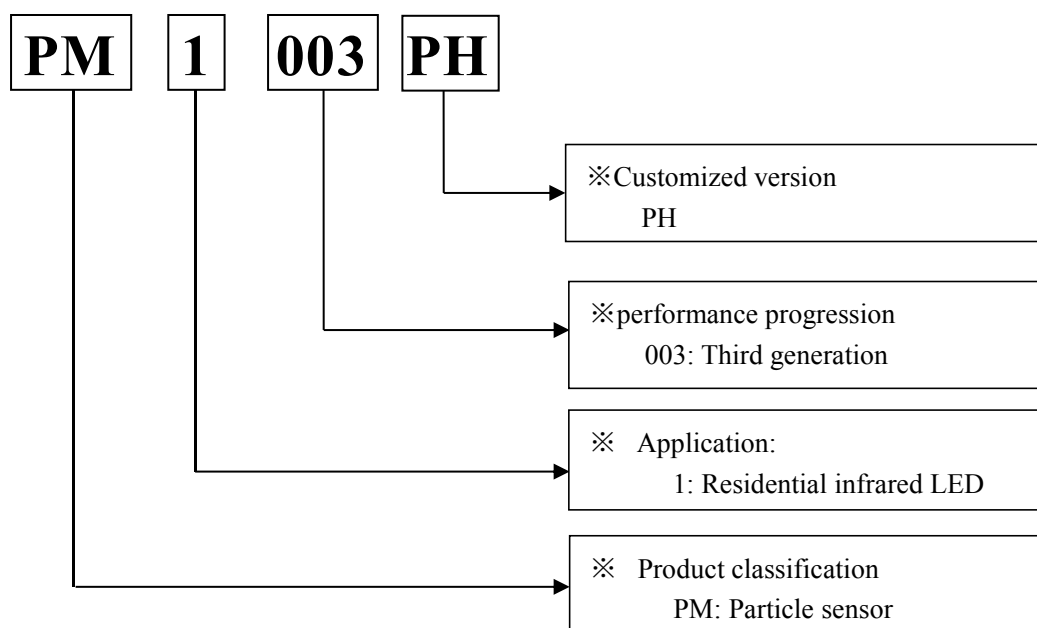



# Packing

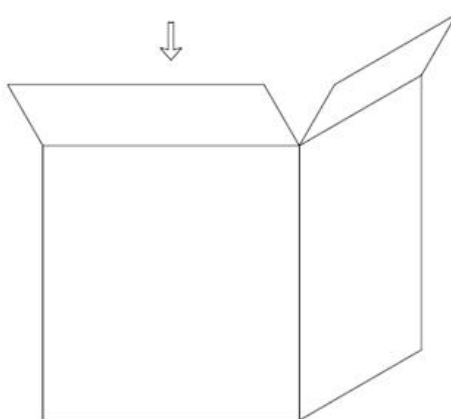
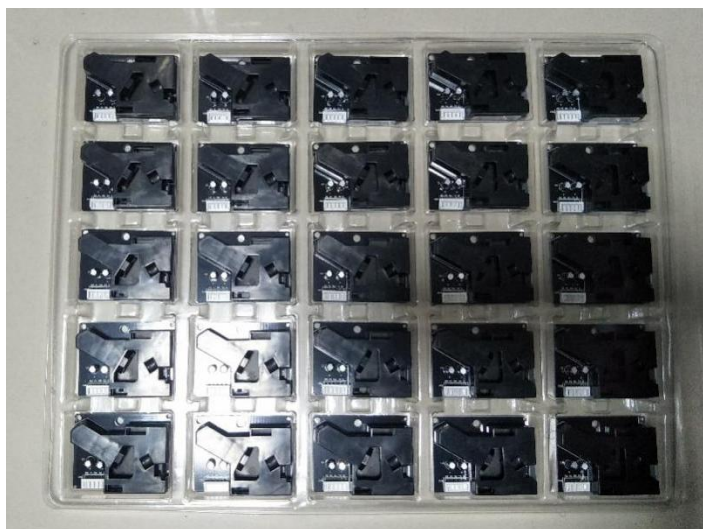

Qty per layer	Layer	Carton	Carton dimensions	Packing material
25pcs	15layers	375pcs	W400 * L300 * H320 mm	PVC plastic tray

## User attention

---

Keep the sensor installed in vertical direction (error  $< \pm 3^\circ$  ). The air inlet is with heat resistance, the position is at the bottom.

Install the sensor inside the device. Adding the black sponge at the front window to make sure it is in dark to reduce the affect of the light interference.

Ensure the ventilation of air inlet and air outlet in installation.

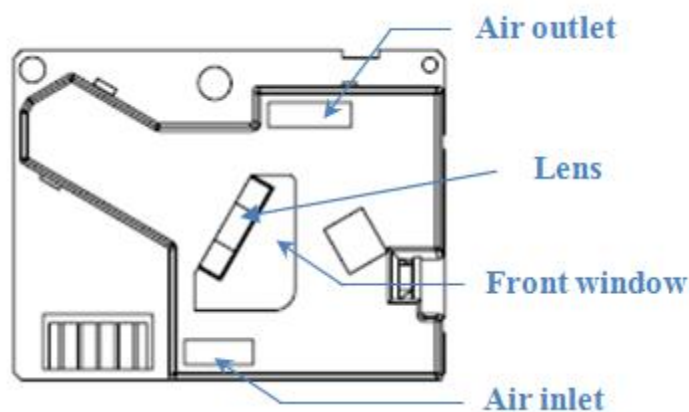

The sensor should not be used in the environment with organic gas and flammable gas. If there is dust in the chamber of the sensor, please use cleaner to clean. Wipe the lens with water and medical cotton swab and clean the lens with clean cotton swabs. Do not use alcohol.

## After-sales services and consultancy

---

**TEL:** 86-27-81628827 **FAX:** 86-27-81628821

**ADD:** Fenghuang No.3 Road, Fenghuang Industrial Park, Eastlake Hi-tech Development  
Zone, Wuhan 430205, China

[Http://www.gassensor.com.cn](http://www.gassensor.com.cn)

**E-mail:** [info@gassensor.com.cn](mailto:info@gassensor.com.cn)