

# SPECIFICATION

Product Name: Electrochemical Formaldehyde Sensor Module

Item No.: CB-HCHO-V5.0 (Fifth Generation)

Version: V0.1

Date: April 17, 2023

# Revision

No.	Version	Content	Date
1	V0.1	First edition	2023.04.17

# Electrochemical Formaldehyde Sensor Module

## CB-HCHO-V5.0 (Fifth Generation)

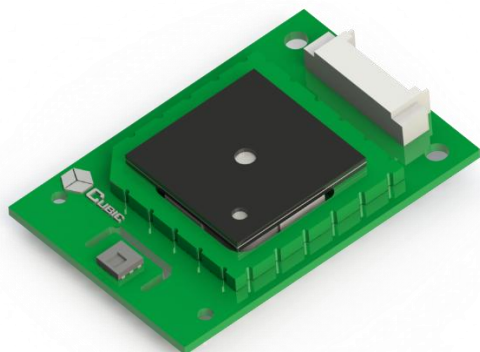

### Applications

- ✧ Portable instrument
- ✧ Desktop air quality monitoring equipment
- ✧ Air Purifier
- ✧ HVAC system
- ✧ Air Conditioner
- ✧ Smart Home

### Description

CB-HCHO the fifth generation formaldehyde sensor is an electrochemical gas concentration sensor. It adopts unique structure design and packaging technology, to avoid electrolyte getting dried. With optimized algorithm and scientific calibration, it can output formaldehyde with high accuracy, also built-in temperature and humidity sensor is integrated for correction algorithm, which makes the formaldehyde sensor available to output accurately at temperature and humidity range.

### Working Principle

When formaldehyde gas passes through the sensor, the formaldehyde molecules undergo oxidation-reduction reaction on the electrode to form an electron transfer under the catalytic action of the electrolyte. This reaction produces a small current, which is proportional to the concentration of the gas present, and the sensor can calculate and output HCHO concentration by the detected current signal.

### Features

- ✧ Low power available for battery powered device
- ✧ High sensitivity up to 1ppb
- ✧ Wide working temperature and humidity range
- ✧ Full range temperature and humidity compensation
- ✧ Excellent anti-interference performance, alcohol cross-interference is less than 0.5%
- ✧ Lifetime can reach up to 10 years

## Specifications

### CB-HCHO-V5.0 Formaldehyde Sensor Module Specification

<b>Working principle</b>	Electrochemical
<b>Measurement range</b>	0~1000ppb
<b>HCHO Measurement accuracy</b>	±20ppb or ±20% of reading, whichever is larger (Reference instrument: Gasera one, 25±2°C, 50±10%RH)
<b>Resolution</b>	1ppb
<b>Response time<sup>1)</sup></b>	T90<120s
<b>Cross sensitivity to ethanol<sup>2)</sup></b>	<0.5%
<b>Working condition</b>	-10~50°C; 10~95%RH (Non- condensing)
<b>Storage condition</b>	-20~60°C; 10~95%RH (Non- condensing)
<b>Working voltage</b>	DC (+3.5V ~ +5.5V), ripple wave<100mV
<b>Working current<sup>3)</sup></b>	<15mA
<b>Signal Output</b>	UART_TTL (3.3V)
<b>Dimension</b>	W35*H5.4*D24mm
<b>Lifetime</b>	>10 years

**Note:**

- 1) At condition of 25±2°C & 50±10%RH, and full range HCHO concentration (1000ppb);
- 2) Tested at 10ppm ethanol, 25±2°C & 50±10%RH;
- 3) The main power consumption is from MCU, for low power application demand, please contact Cubic;

## Outline Structure and Interface Definition

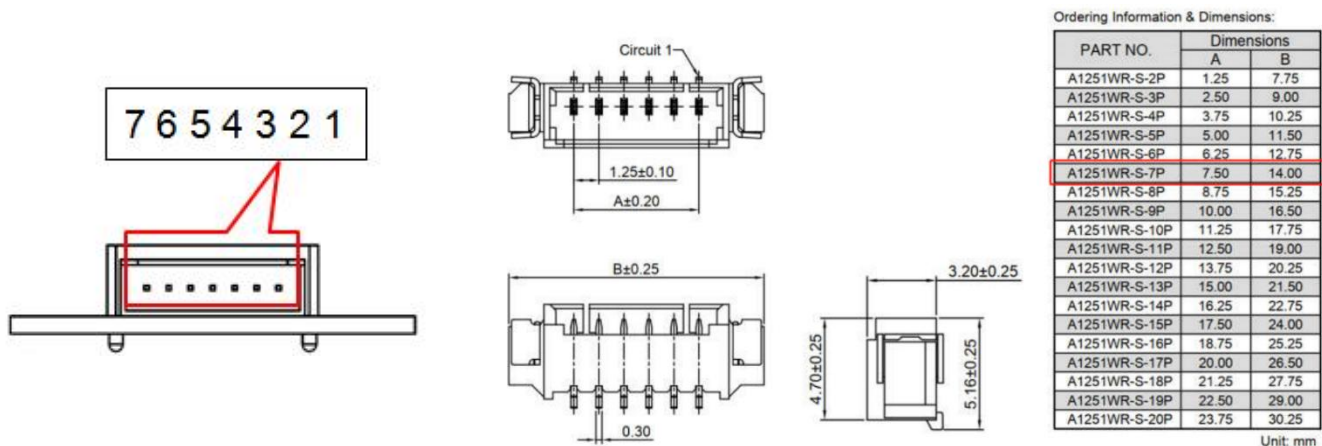

Figure 1: Interface and Connector Definition

### Pin Definition Table

No.	Pin	Description
1	NC	Floating
2	PWM	PWM Output
3	GND	Power input (Ground)
4	VCC	Power input (+5V)
5	RXD	Signal receiver
6	TXD	Signal output
7	NC	Floating

## Sensor Dimension

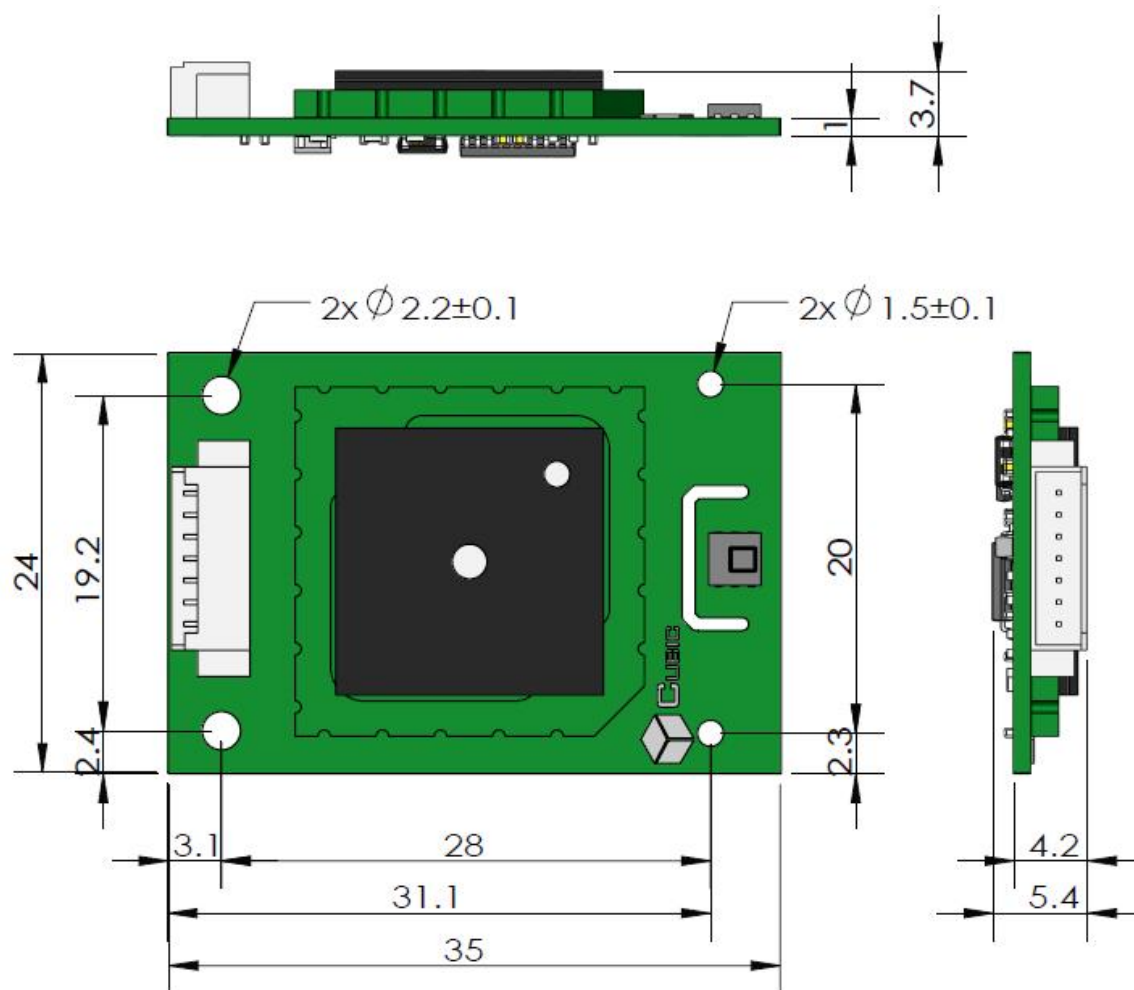

Figure 2: CB-HCHO-V5.0 (Fifth Generation) dimension (unit: mm, tolerance $\pm 0.2$ mm)

## Communication Protocol

### 1. General Statement

- 1) The data in this protocol is all hexadecimal data. For example, "46" for decimal [70].
- 2) [xx] is for single-byte data (unsigned, 0-255); for double data, high byte is in front of low byte.
- 3) Baud rate: 9600; Data Bits: 8; Stop Bits: 1; Parity: No

### 2. Format of Serial Communication Protocol

Sending format of upper computer:

Start symbol	Length	Command	Data 1	...	Data n	Check Sum
HEAD	LEN	CMD	DATA1	...	DATAn	CS
11H	XXH	XXH	XXH	...	XXH	XXH

Detail description on protocol format:

Protocol	Description
Start symbol	Sending by upper computer is fixed as [11H], module respond is fixed as [16H]
Length	Length of frame bytes= data length +1 (including CMD+DATA)
Command	Command
Data	Data of writing or reading, length is not fixed
Check Sum	Cumulative sum of data = 256- (HEAD+LEN+CMD+DATA)

### 3. Command Table of Serial Protocol

No.	Function	Command	Function description
1	Query Command	0x01	Query concentration
2	Auto-Calibration	0x03	Calibration Switch

### 4. Content of Protocol

#### 4.1 Read Formaldehyde Concentration

**Send:** 11 01 01 ED

**Response:** 16 0D 01 DF1-DF2 DF3-DF4 DF5-DF6 DF7-DF8 DF9-DF10 DF11-DF12 [CS]

**Response Description:**

1. HCHO concentration value = (DF1\*256 + DF2) (Unit: ppb)
2. Temperature value = (DF5\*256 + DF6)/10 (Unit: °C)
3. Humidity value = (DF7\*256 + DF8)/10 (Unit: %)
4. Sensor Status byte = DF11 Sensor Status byte

5. Auto calibration switch byte = DF12 Auto calibration switch byte
6. DF3, DF4, DF9, DF10 are reserved bytes.

Sensor status byte corresponds to the sensor state:

0	1	2	3
Sensor normal working	Sensor anomaly (Poisoning, lifetime end, failure, etc.)	Sensor in recovery process	High formaldehyde concentration environment

Auto calibration switch byte

0	1
Auto calibration is off	24hs auto calibration is on

## 4.2 Auto-calibration Setting command

**Send:** 11 02 03 DF1 [CS]

**Response:** 16 02 03 DF1 [CS]

### Response Description:

1. DF1 = 00, HCHO manual calibration
2. DF1 = 01, HCHO auto-calibration
3. DF1 = 02, HCHO calibration value clearing

Remark:

1. The auto-calibration is off as default
2. When auto-calibration is set open, the sensor needs to be continuously powered on. When the sensor is power off, and powered on again, the auto-calibration is closed by default.



## Notice

---

1. Preheating time shall be at least 48 hours for the first time use or after long time storage.
2. Soldering is prohibited for installation.
3. Recommended storage temperature is 0 ~ 20°C, high temperature environment may reduce the sensor server life.
4. To avoid electrolyte damage, the user shall not disassembly the sensor.
5. To avoid sensor poisoning, do not let the sensor contact with organic solvents (including silicon rubber, adhesive), paint, medicament, oil or high HCHO gas (>5ppm).
6. The sensor performance might be influenced if keep it in oxygen-free environment.
7. The sensor shall not be used in environment with corrosive gases.

## After-sales Services and Consultancy

---

Tel: 86-27-8162 8827

Add: Fenghuang No.3 Road, Fenghuang Industrial Park, Eastlake Hi-tech Development Zone, Wuhan, 430205, China

Zip: 430205

Fax: 86-27-8740 1159

Website: <http://www.gassensor.com.cn>

E-mail: [info@gassensor.com.cn](mailto:info@gassensor.com.cn)