



# PRODUCT SPECIFICATION

DOCUMENT NO. ENS000155750

DESCRIPTION	DRAWN BY	DESIGNED BY	CHECKED BY	APPROVED BY
CSMM2010D-XXXM-LRH	Zhuoling Tang	Shengjun Zhou	Shengjun Zhou	Dick Wang

1. PART NUMBER IDENTIFICATION

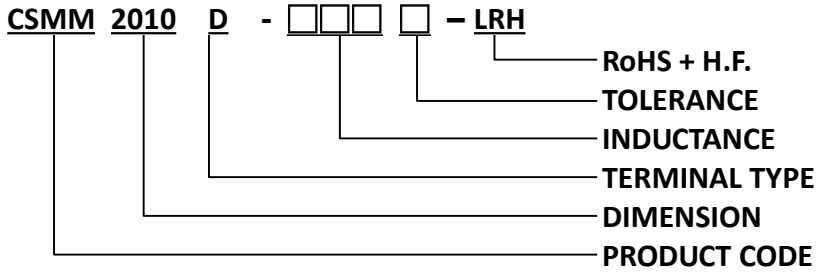

2. MECHANICAL DIMENSION

UNIT: mm

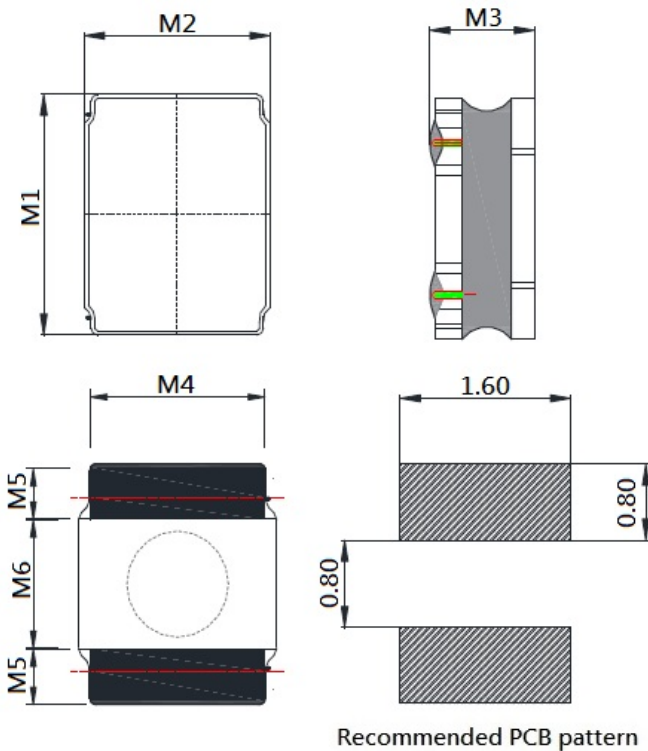

	DIM.	TOL.
M1	2.0	±0.2
M2	1.6	±0.2
M3	1.0	±0.2
M4	1.6	±0.2
M5	0.6	±0.2
M6	0.8	±0.2

3. RATING TEMPERATURE

OPERATING TEMPERATURE RANGE (individual chip without packing): -40°C~+125°C (Including Self-heating).

STORAGE TEMPERATURE RANGE (packaging conditions): -10°C~+40°C and RH 70% (Max.).

## 4. STRUCTURE

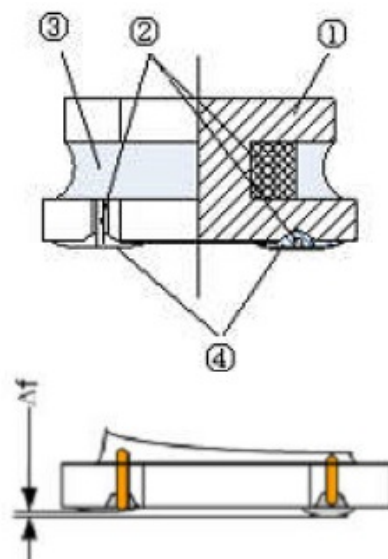

$\Delta f$ : Clearance between terminal and the surface of plate must be 0.1mm max when coil is placed on a flat plate.

## 5. MATERIAL LIST

ITEM	MATERIAL CATEGORY	MATERIAL TYPE
1	Core	Soft magnetic Metal
2	Wire	Polyurethane system enameled copper wire
3	Magnetic Glue	Epoxy resin and magnetic powder
4	Electrodes	Ag Ni Sn or Fe Ni Cu + Sn Alloy

## 6. ELECTRICAL SPECIFICATION

Part number	Inductance (μH)	Inductance Tolerance	Test Frequency (MHz/V)	DC Resistance (Ω) MAX.	DC Resistance (Ω) TYP.	Isat (A) MAX.	Isat (A) TYP.	Irms (A) MAX.	Irms (A) TYP.
CSMM2010D-R24□-LRH	0.24	M	1/1	0.040	0.033	4.50	5.50	3.00	3.45
CSMM2010D-R33□-LRH	0.33	M	1/1	0.049	0.041	4.40	5.20	2.70	3.10
CSMM2010D-R47□-LRH	0.47	M	1/1	0.049	0.041	4.06	4.70	2.70	3.10
CSMM2010D-R56□-LRH	0.56	M	1/1	0.053	0.043	3.80	4.50	2.60	2.80
CSMM2010D-R68□-LRH	0.68	M	1/1	0.065	0.057	3.50	4.00	2.50	2.80
CSMM2010D-1R0□-LRH	1.0	M	1/1	0.095	0.078	3.30	3.80	2.00	2.30
CSMM2010D-1R5□-LRH	1.5	M	1/1	0.130	0.110	1.95	2.30	1.70	2.00
CSMM2010D-2R2□-LRH	2.2	M	1/1	0.180	0.160	1.90	2.15	1.40	1.60
CSMM2010D-3R3□-LRH	3.3	M	1/1	0.307	0.245	1.40	1.60	1.10	1.30
CSMM2010D-4R7□-LRH	4.7	M	1/1	0.425	0.370	1.10	1.40	0.90	1.00
CSMM2010D-6R8□-LRH	6.8	M	1/1	0.620	0.500	0.95	1.10	0.70	0.82
CSMM2010D-8R2□-LRH	8.2	M	1/1	0.870	0.670	0.86	1.00	0.66	0.76
CSMM2010D-100□-LRH	10	M	1/1	0.875	0.700	0.80	0.95	0.60	0.70

## NOTE:

□ Inductance Tolerance: M: ±20%

1. Rated current: Isat (max.) or Irms (max.), whichever is smaller.
2. Saturation Current: Max. Value, DC current at which the inductance drops less than 30% from its value without current; Typ. Value, DC current at which the inductance drops 30% from its value without current.
3. Irms: DC current that causes the temperature rise ( $\Delta T$ ) from 20°C ambient.  
For Max. Value,  $\Delta T < 40^\circ\text{C}$ ; For Typ. Value,  $\Delta T$  is approximate 40°C.
4. The part temperature (ambient + temp. rise) should not exceed 125°C under worst case operating conditions.  
Circuit design, component placement, PCB trace size and thickness, airflow and other cooling provisions all affect the part temperature. Part temperature should be verified in the end application.
5. Absolute maximum voltage: DC 25V
6. MSL: Level 1

7. RELIABILITY PERFORMANCE

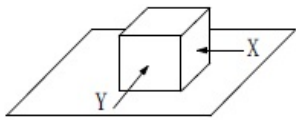
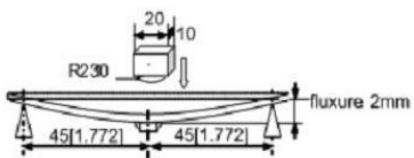
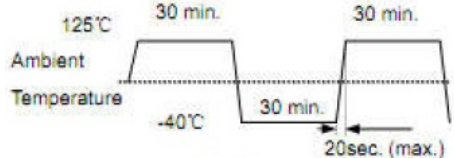
Items	Requirements	Test Methods and Remarks
Terminal Strength	<p>No removal or split of the termination or other defects shall occur.</p>  <p>Fig.7.1-1</p>	<ol style="list-style-type: none"> <li>Solder the inductor to the testing jig (glass epoxy board shown in Fig.7.1-1) using eutectic solder. Then apply a force in the direction of the arrow.</li> <li>10N force.</li> <li>Keep time: 5s</li> </ol>
Resistance to Flexure	<p>No visible mechanical damage.</p>  <p>Fig.7.2-1</p>	<ol style="list-style-type: none"> <li>Solder the chip to the test jig (glass epoxy board) using eutectic solder. Then apply a force in the direction shown as Fig.7.2-1.</li> <li>Flexure: 2mm</li> <li>Pressurizing Speed: 0.5mm/sec</li> <li>Keep time: 30±1s</li> <li>Test board size: 100×40×1.0</li> <li>Land dimension</li> </ol>
Vibration	<ol style="list-style-type: none"> <li>No visible mechanical damage.</li> <li>Inductance change: Within ±10%</li> </ol>	<ol style="list-style-type: none"> <li>Solder the chip to the testing jig (glass epoxy board shown as the following figure) using eutectic solder</li> <li>The chip shall be subjected to a simple harmonic motion having total amplitude of 1.5mm, the frequency being varied uniformly between the approximate limits of 10 and 55Hz.</li> <li>The frequency range from 10 to 55Hz and return to 10Hz shall be traversed in approximately 1 minute. This motion shall be applied for a period of 2 hours in each 3 mutually perpendicular directions (total of 6 hours).</li> </ol>
Temperature coefficient	<p>Inductance change: Within ±20%</p>	<ol style="list-style-type: none"> <li>Temperature: -40°C~+125°C</li> <li>With a reference value of +20°C, change rate shall be calculated</li> </ol>
Solderability	<p>90% or more of electrode area shall be coated by new solder</p>	<ol style="list-style-type: none"> <li>The test samples shall be dipped in flux, and then immersed in molten solder.</li> <li>Solder temperature: 245±5°C</li> <li>Duration: 5±1sec.</li> <li>Solder: Sn/3.0Ag/0.5Cu</li> <li>Flux: 25% resin and 75% ethanol in weight</li> <li>Immersion depth: all sides of mounting terminal shall be immersed</li> </ol>
Thermal Shock	<ol style="list-style-type: none"> <li>No visible mechanical damage.</li> <li>Inductance change: Within ±10%</li> </ol>  <p>Fig.7.7-1</p>	<ol style="list-style-type: none"> <li>Temperature and time: -40±3°C for 30±3 min→125°C for 30±3min, please refer to Fig.7.7-1.</li> <li>Transforming interval: Max, 20sec</li> <li>Tested cycle: 100 cycles</li> <li>The chip shall be stabilized at normal condition for 1~2 hours before measuring</li> </ol>

Items	Requirements	Test Methods and Remarks
Resistance to Low Temperature	<ol style="list-style-type: none"> <li>1. No visible mechanical damage</li> <li>2. Inductance change: Within <math>\pm 10\%</math></li> </ol>	<ol style="list-style-type: none"> <li>1. Temperature and time: <math>-40\pm 3^{\circ}\text{C}</math></li> <li>2. Duration: <math>1000\pm 24</math> hours</li> <li>3. The chip shall be stabilized at normal condition for 1~2 hours before measuring</li> </ol>
Resistance to High Temperature	<ol style="list-style-type: none"> <li>1. No visible mechanical damage</li> <li>2. Inductance change: Within <math>\pm 10\%</math></li> </ol>	<ol style="list-style-type: none"> <li>1. Temperature and time: <math>125\pm 2^{\circ}\text{C}</math></li> <li>2. Duration: <math>1000\pm 24</math> hours</li> <li>3. The chip shall be stabilized at normal condition for 1~2 hours before measuring</li> </ol>
Damp Heat	<ol style="list-style-type: none"> <li>1. No visible mechanical damage</li> <li>2. Inductance change: Within <math>\pm 10\%</math></li> </ol>	<ol style="list-style-type: none"> <li>1. Temperature and time: <math>60\pm 2^{\circ}\text{C}</math></li> <li>2. Humidity: 90% to 95% RH</li> <li>3. Duration: <math>1000\pm 24</math> hours</li> <li>4. The chip shall be stabilized at normal condition for 1~2 hours before measuring</li> </ol>
Loading Under Damp Heat	<ol style="list-style-type: none"> <li>1. No visible mechanical damage</li> <li>2. Inductance change: Within <math>\pm 10\%</math></li> </ol>	<ol style="list-style-type: none"> <li>1. Temperature and time: <math>60\pm 2^{\circ}\text{C}</math></li> <li>2. Humidity: 90% to 95% RH</li> <li>3. Applied current: Rated current</li> <li>4. Duration: <math>1000\pm 24</math> hours</li> <li>5. The chip shall be stabilized at normal condition for 1~2 hours before measuring</li> </ol>
Loading at High Temperature	<ol style="list-style-type: none"> <li>1. No visible mechanical damage</li> <li>2. Inductance change: Within <math>\pm 10\%</math></li> </ol>	<ol style="list-style-type: none"> <li>1. Temperature and time: <math>85\pm 2^{\circ}\text{C}</math></li> <li>2. Applied current: Rated current</li> <li>3. Duration: <math>1000\pm 24</math> hours</li> <li>4. The chip shall be stabilized at normal condition for 1~2 hours before measuring</li> </ol>

8. REFLOW CHART

Typical RoHS Reflow Profile

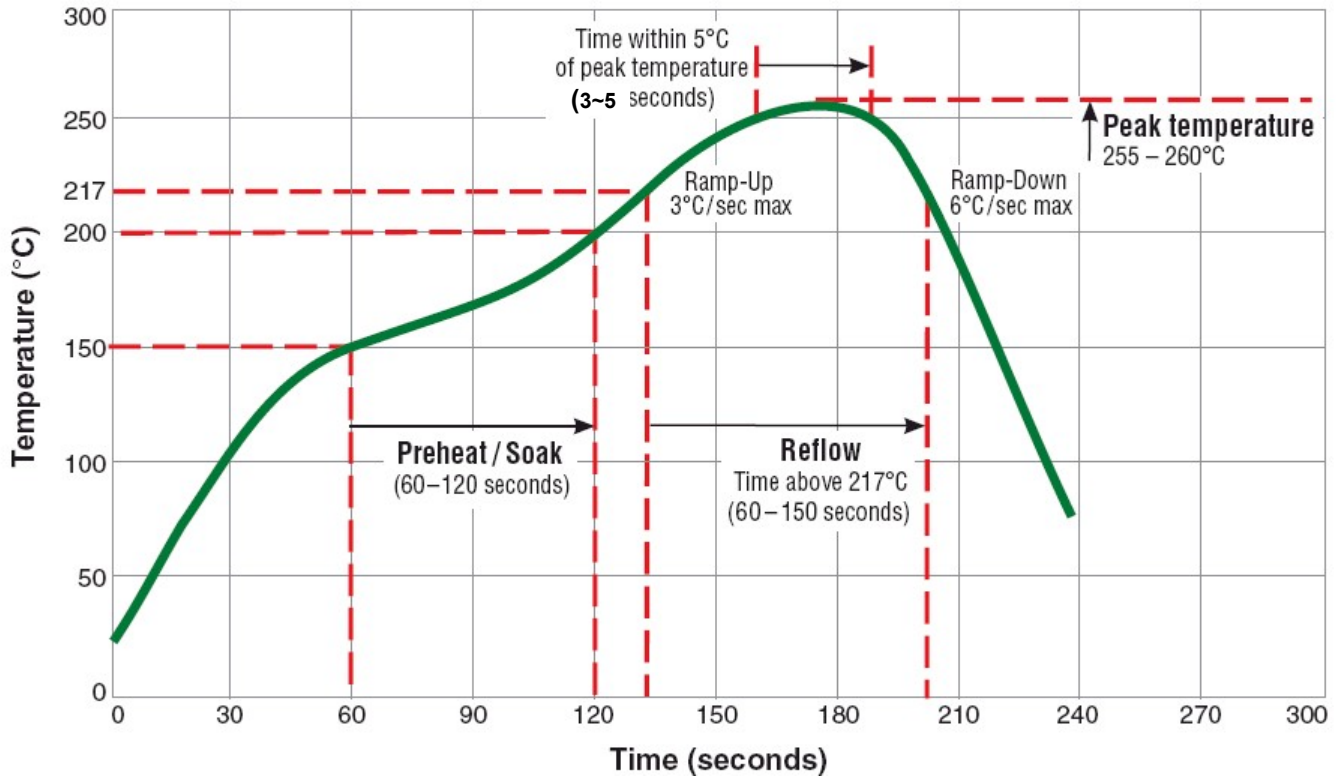

9. PACKING

9-1. Carrier Tape Dimensions:

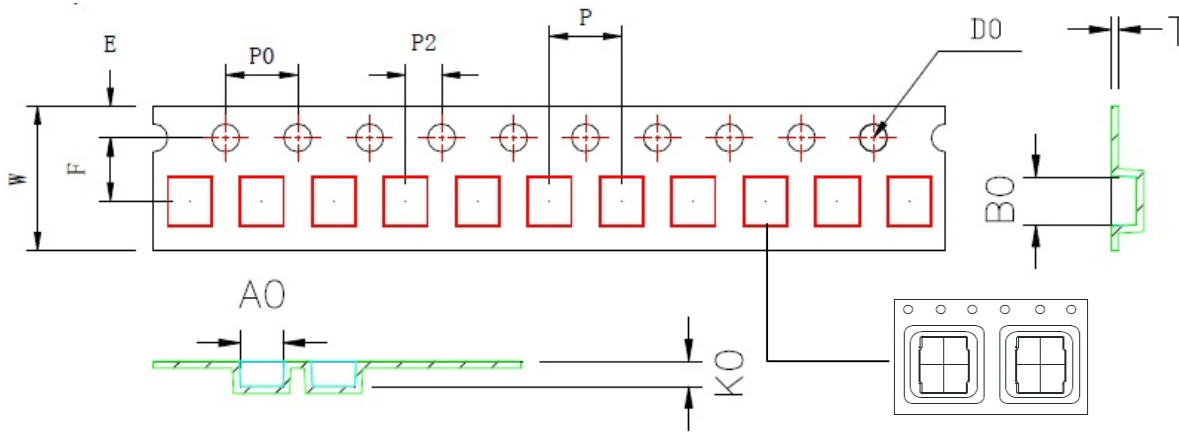

UNIT : mm

	W	A0	B0	K0	P	F	E	D0	P0	P2	T
DIM.	8.00	2.0	2.4	1.2	4.00	3.50	1.75	1.50	4.00	2.00	0.25
TOL.	±0.3	±0.1	±0.1	±0.1	±0.1	±0.1	±0.1	+0.1	±0.1	±0.1	±0.05

9-2. Reel Dimensions

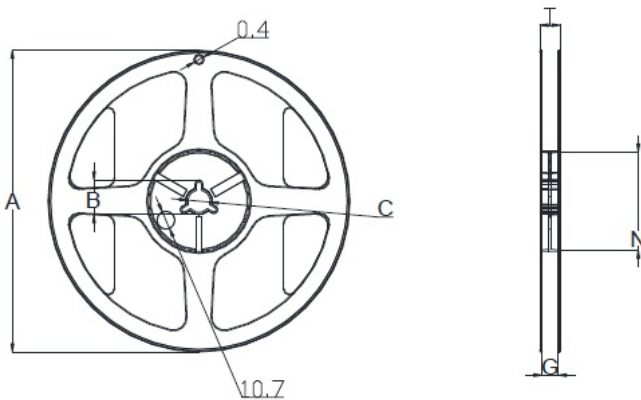

Type	A	B	C	G	N	T
8 mm	178	20.7±0.8	13±0.4	9	60	10.8

9-3. Packaging Quantity:

2KPCS/ Reel 20KPCS/ Inner Box 80KPCS/ Outer Box