



PRODUCT SPECIFICATION

DOCUMENT NO. ENS000153140

DESCRIPTION	DRAWN BY	DESIGNED BY	CHECKED BY	APPROVED BY
CSME0315D-XXXX-LRH	Zhuoling Tang	Tieqiao Gong	Tieqiao Gong	Dick Wang

1. SCOPE: THIS SPECIFICATION APPLIES TO WIRE WOUND CHIP INDUCTORS.

2. PART NUMBER IDENTIFICATION

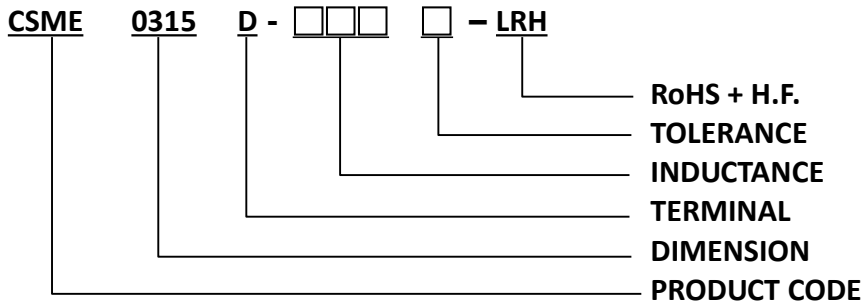

3. MECHANICAL DIMENSION

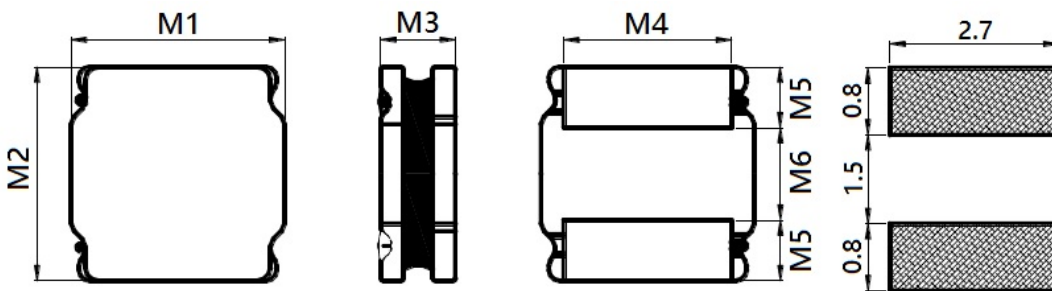

SERIES	M1	M2	M3	M4	M5	M6
CSME0315D	3.0(±0.2)	3.0(±0.2)	1.35(±0.15)	2.7(±0.2)	0.75(±0.2)	1.5(±0.2)

4. RATING TEMPERATURE

OPERATING TEMPERATURE RANGE : -40°C TO +125°C.

STORAGE TEMPERATURE RANGE: COMPONENT: -40°C TO +125°C.

5. STRUCTURE

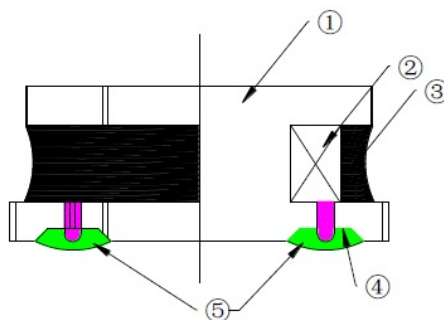

6. MATERIAL LIST

ITEM	MATERIAL CATEGORY	MATERIAL TYPE
1	WIRE	POLYURETHANE ENAMELED COPPER WIRE
2	CORE	Ni-Zn FERRITE CORE
3	ADHESIVE	EPOXY RESIN MAGNETIC POWDER
4	PLATING ELECTRODES	PLATING: Ag 10-20 um Ni 1-3 um Sn 3-7 um
5.	OUTER ELECTRODES	TOP SURFACE SOLDER COATING Sn99%、Ag0.3%、Cu0.7%

7. TEST INSTRUMENT

7-1 Inductance、TEST BY HIOKI3532-50 OR EQUIVALENT7-2 ISAT / IRMS TEST BY HP4284+42841A OR EQUIVALENT7-3 DC Resistance TEST BY HIOKI 3540 OR EQUIVALENT

8. ELECTRICAL SPECIFICATION

Part number	Inductance (uH)	DC Resistance (mΩ) ±30%	Isat (A) MAX.	Irms (A) MAX.	SRF (MHz) MIN.
CSME0315D-1R0N-LRH	1.0	30	2.10	2.10	73.0
CSME0315D-1R5N-LRH	1.5	38	1.80	1.82	58.0
CSME0315D-2R2M-LRH	2.2	58	1.48	1.50	53.0
CSME0315D-3R3M-LRH	3.3	78	1.21	1.23	42.0
CSME0315D-4R7M-LRH	4.7	120	1.02	1.04	34.0
CSME0315D-6R8M-LRH	6.8	160	0.87	0.88	26.0
CSME0315D-100M-LRH	10	220	0.70	0.71	17.6
CSME0315D-220M-LRH	22	520	0.47	0.47	14.0
CSME0315D-330M-LRH	33	780	0.39	0.45	12.0
CSME0315D-101M-LRH	100	2300	0.23	0.25	7.0

NOTE:

1. □TOLERANCE: M:±20%、N:±30%

2. MSL: LEVEL 1

3. INDUCTANCE : @100KHz,0.25V

4. INDUCTANCE DROPS NO MORE THAN 30% OF INITIAL VALUE AT ISAT.

5. TEMPERATURE RISES : Δ t< 40°C AT IRMS.

9. RELIABILITY PERFORMANCE

9-1.Storage Temperature range : $-40^{\circ}\text{C} \sim +125^{\circ}\text{C}$

9-2.Operating temperature range : $-40^{\circ}\text{C} \sim +125^{\circ}\text{C}$ (Including coil's self temperature rise)

9-3.External appearance : No external defects can be found in the visual inspection.

9-4.Electrode strength : No electrode detachment should be found when the device is pushed in two directions of X and Y with the force of 10.0N for 10 ± 2 seconds after soldering between copper plate and the electrodes. (Refer to figure at right)

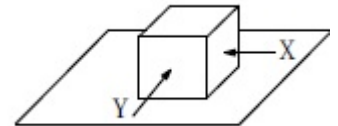

9-5.Vibration test : Inductance deviation is within $\pm 10.0\%$ after 1 hour sweeping vibration in each three directions, namely, forward and backward, up and down, right and left. The frequency is $10 \sim 55 \sim 10\text{Hz}$ and the amplitude of 1 minute cycle is 1.5mm PP.

9-6.Humidity test : Inductance deviation is within $\pm 5.0\%$ after 96 ± 4 hours test under the condition of relative humidity of $90 \sim 95\%$ and temperature of $60 \pm 2^{\circ}\text{C}$, and 1 hour storage under room ambient conditions after the device is wiped with dry cloth.

10. REFLOW CHART

Typical RoHS Reflow Profile

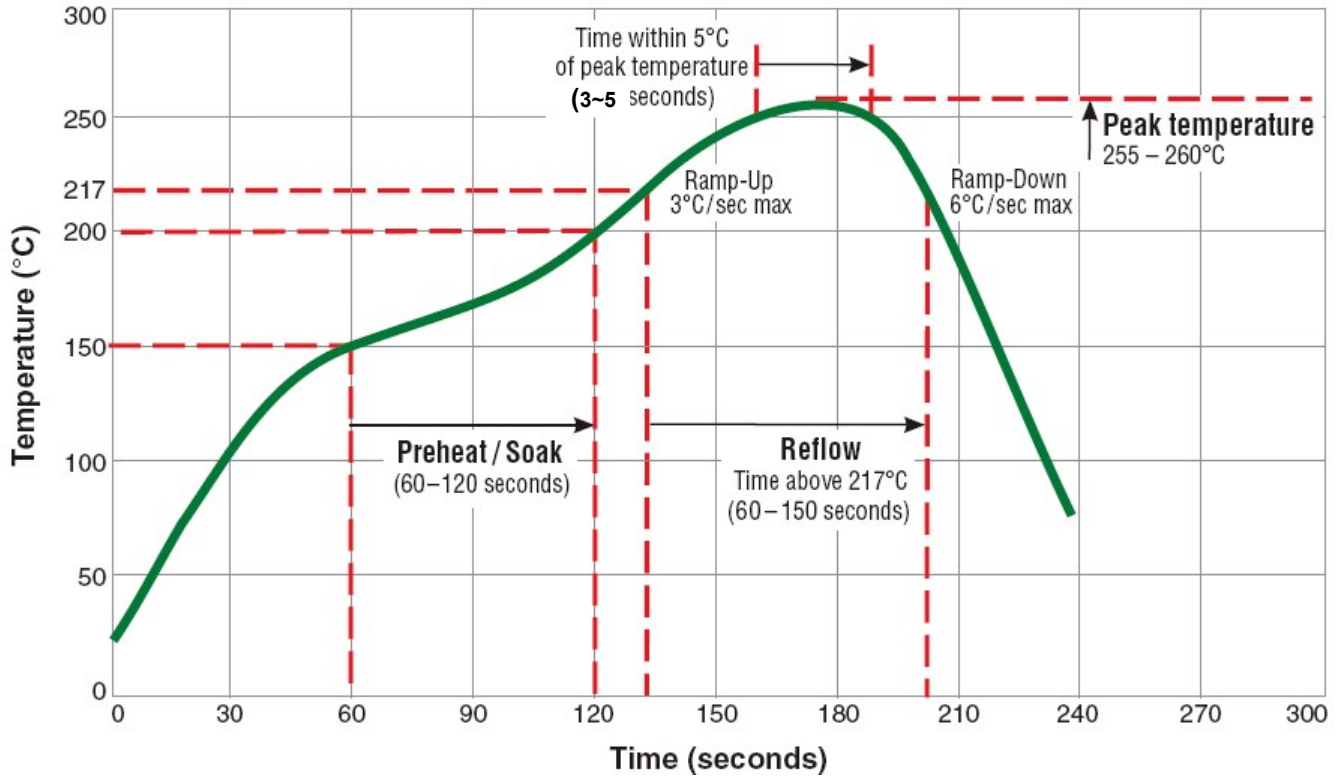

11. PACKING

11-1 OUTER PACKING

2 KPCS/REEL;20 KPCS/INNER BOX;80 KPCS/OUTER BOX

11-2 CARRIER TAPE DIMENSIONS

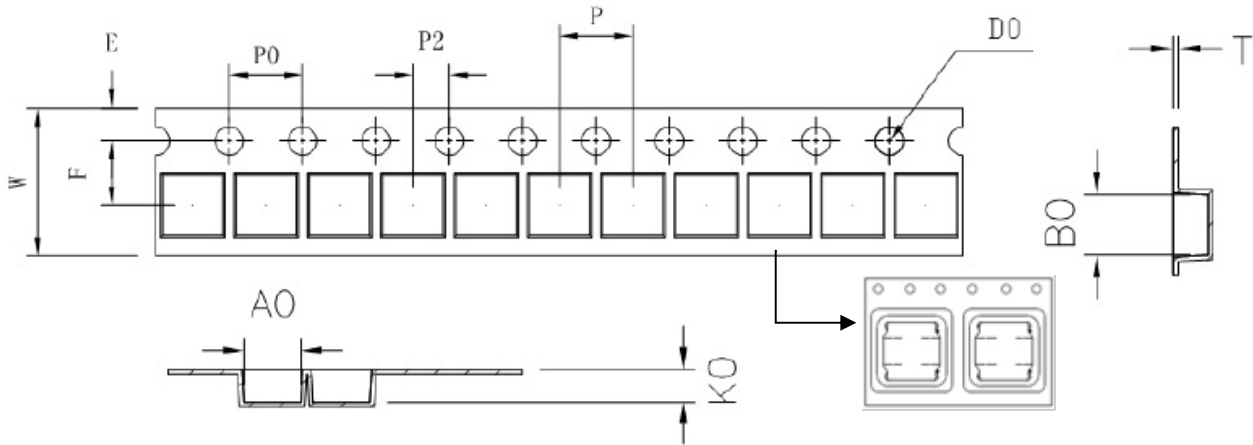

UNIT: mm

ITEM	W	P	F	E	D0	P0	P2	T	A0	B0	K0
DIM	8.00	4.00	3.50	1.75	1.50	4.00	2.00	0.25	3.3	3.3	1.9
TOLE	±0.3	±0.1	±0.05	±0.1	+0.1	±0.1	±0.05	±0.05	±0.05	±0.05	±0.05

11-3 CARRIER REEL DIMENSIONS

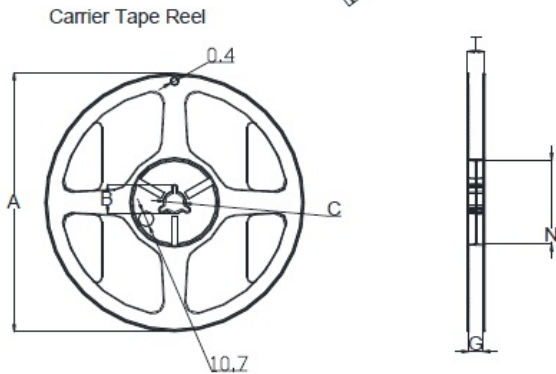
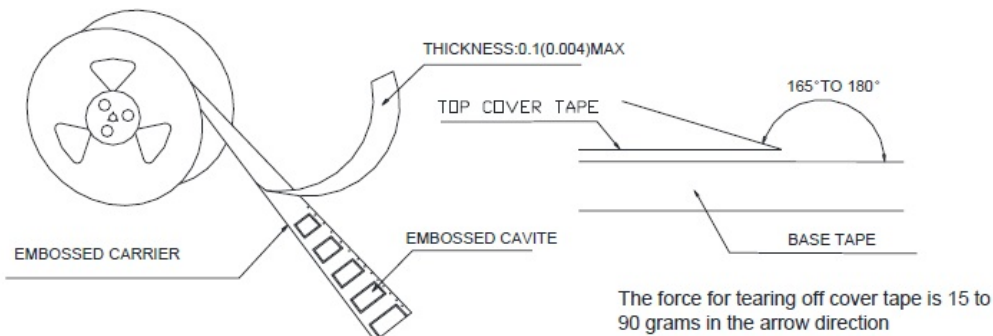

UNIT:mm

Type	A	B	C	G	N	T
8mm	178	20.7±0.8	13±0.4	9	60	10.8