

Harvatek Surface Mount CHIP LEDs Data Sheet B3DK3BRG-12C000113E0118 *(Preliminary)*

Features

- Support signal reshaping to pass control waveforms to next adjacent driver
- Cascading port transmission by a single data line
- Built-in current regulator, three-way drive.
- Optional- Optional maximal drive current: 5mA 、 12mA 、 20mA
- 256-step gray-scale output to allow 16,777,216 color display
- Built-in oscillator 20MHz
- LED driver port maximum withstand Voltage 6.5V
- Built-in power-on-reset (2.6V) (@VDD=5V)
- Operating voltage 4.5~5.5V

Applications

- Decorative LED lighting
- LED video display

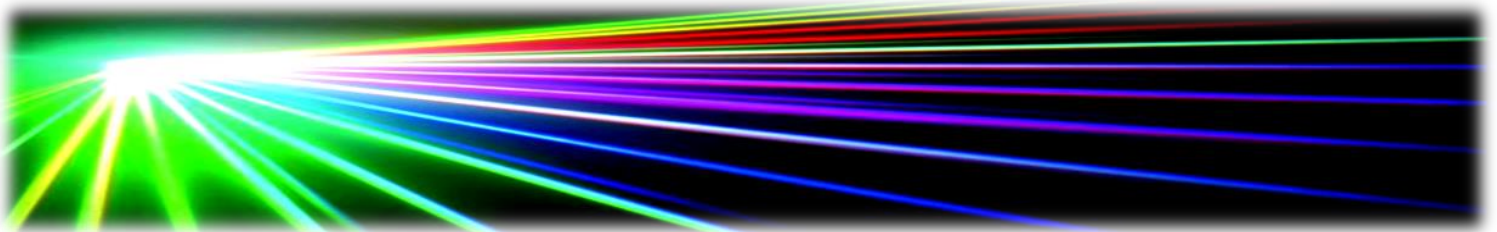

Official Product	HT Part No. B3DK3BRG-12C000113E0118		
Tentative Product	*****	*****	*****
Specifications are subject to changes for improvement without advance notice. Proprietary data, drawings, company confidential all rights reserved.		10/22/2019	Preliminary Page 1/15

DISCLAIMER	3
LIFE SUPPORT POLICY	3
PRODUCT SPECIFICATIONS	4
ATTENTION: ELECTROSTATIC DISCHARGE (ESD) PROTECTION	4
LABEL SPECIFICATIONS	5
SPECIFICATIONS RANGE	6
PRODUCT FEATURES	7
ELECTRO-OPTICAL CHARACTERISTICS	7
PACKAGE OUTLINE DIMENSION AND RECOMMENDED SOLDERING PATTERN FOR REFLOW	
SOLDERING	7
ELECTRICAL CHARACTERISTICS	8
DATA TRANSFER PROTOCOL	9
PRECAUTION FOR USE	10
PACKAGING	11
TAPE DIMENSION	11
REEL DIMENSION	12
PACKING	12
DRY PACK	13
BAKING	13
PRECAUTIONS	13
REFLOW SOLDERING	14
REWORKING	14
CLEANING	14
CAUTIONS OF PICK AND PLACE	15
REVISE HISTORY	15

Official Product	HT Part No. B3DK3BRG-12C000113E0118		
Tentative Product	*****	*****	
Specifications are subject to changes for improvement without advance notice. Proprietary data, drawings, company confidential all rights reserved.		10/22/2019	Preliminary Page 2/15

DISCLAIMER

HARVATEK reserves the right to make changes without further notice to any products herein to improve reliability, function or design. HARVATEK does not assume any liability arising out of the application or use of any product or circuit described herein; neither does it convey any license under its patent rights, nor the rights of others.

Life Support Policy

HARVATEK's products are not authorized for use as critical components in life support devices or systems without the express written approval of the President of HARVATEK or HARVATEK INTERNATIONAL. As used herein:

1. Life support devices or systems are devices or systems which, (a) are intended for surgical implant into the body, or (b) support or sustain life, and (c) whose failure to perform when properly used in accordance with instructions for use provided in the labeling, can be reasonably expected to result in a significant injury of the user.
2. A critical component in any component of a life support device or system whose failure to perform can be reasonably expected to cause the failure of the life support device or system, or to affect its safety or effectiveness.

Official Product	HT Part No. B3DK3BRG-12C000113E0118		
Tentative Product	*****	*****	*****
Specifications are subject to changes for improvement without advance notice. Proprietary data, drawings, company confidential all rights reserved.	10/22/2019	Preliminary	Page 3/15

Product Specifications

Item	Specification	Material	Quantity
Luminous Intensity(Iv)	Red : 112~250 mcd Green : 250~450 mcd Blue : 45~112 mcd IC@5V, R/G/B@12mA Ts= 25 ^o C; Tolerance ±10%		
Wavelength	Red : 620~625 nm Green : 520~535 nm Blue : 460~472 nm IC@5V, R/G/B@12mA Ts= 25 ^o C; Tolerance ±10%		
Applied voltage	5V_DC		
View angle	120 ^o		
Resin	Clear	Epoxy	
Carrier tape		Conductive black tape	3000 ea/reel
Reel		Conductive black	
Label	HT standard	Paper	
Packing bag	220x240mm	Aluminum laminated bag/ no-zipper	One reel per bag
Carton	HT standard	Paper	Non-specified

Others:

Each immediate box consists of 5 reels. The 5 reels may not necessarily have the same lot number or the same bin combinations of Iv, λD and Vf. Each reel has a label identifying its specification; the immediate box consists of a product label as well.

Note :This is shipped test conditions

※Remarks: This product should be operated in forward bias. If a reverse voltage is continuously applied to the product, such operation can cause migration resulting in LED damage.

ATTENTION: Electrostatic Discharge (ESD) protection



The symbol to the left denotes that ESD precaution is needed. ESD protection for GaP and AlGaAs based chips is necessary even though they are relatively safe in the presence of low static-electric discharge. Parts built with AlInGaP, GaN, or/and InGaN based chips are **STATIC SENSITIVE devices**. ESD precaution must be taken during design and assembly.

If manual work or processing is needed, please ensure the device is adequately protected from ESD during the process.

Official Product	HT Part No. B3DK3BRG-12C000113E0118		
Tentative Product	*****	*****	
Specifications are subject to changes for improvement without advance notice. Proprietary data, drawings, company confidential all rights reserved.	10/22/2019	Preliminary	Page 4/15

Label Specifications



Harvatek P/N:

B 3DK 3 BRG- 12C- 0001 13 E0118

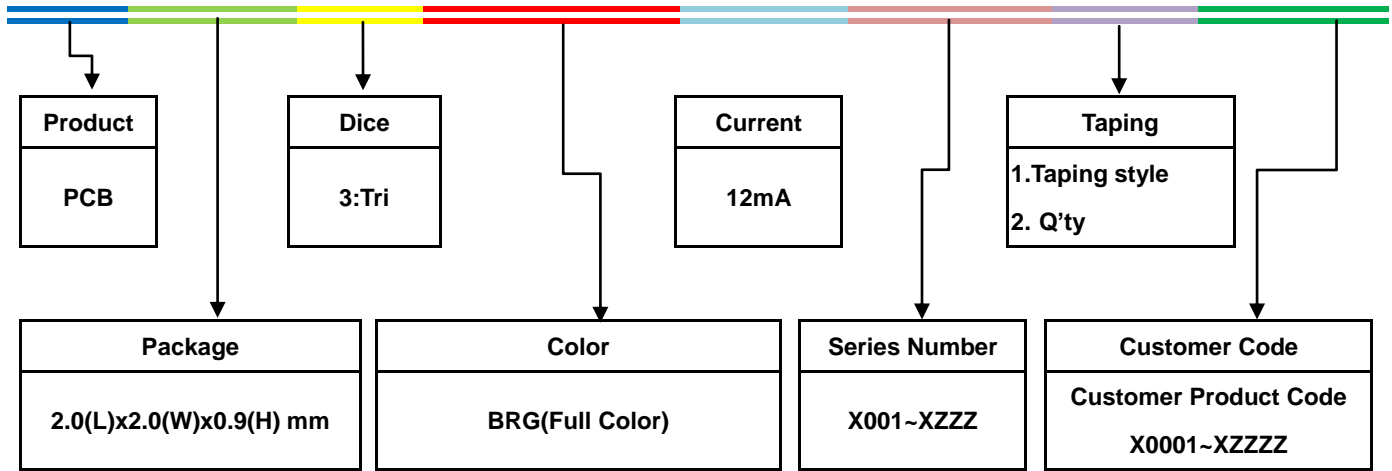

Lot No.:

1	2	3	4	5	6	7	8	9	10
E	1	A	1	A	2	2	L	1	2
Code 1 2		Code 3	Code 4	Code 5	Code 6	Code 7	Code 8	Code 9	Code 10
		Mfg. Year	Mfg. Month	Mfg. Date	Consecutive number		Special code		
Internal Tracing Code		2010-A		1:A	01~ZZ		000~ZZZ		
		2011-B		2:B					
		2012-C	1:Jan.	3:C					
		...	2:Feb.	...					
		2018-I/J	...	26:Z					
		2019-K	A:Oct.	27:7					
		...	B:Nov.	28:8					
2022-N	C:Dec.	29:9							
2023-P		30:3							
...		31:4							

Official Product	HT Part No. B3DK3BRG-12C000113E0118		
Tentative Product	*****	*****	*****
Specifications are subject to changes for improvement without advance notice. Proprietary data, drawings, company confidential all rights reserved.		10/22/2019	Preliminary Page 5/15

Specifications Range

■ Luminous Intensity (Iv) :

Color	Spec. Range
R	112-250 mcd
G	250-450 mcd
B	45-112 mcd

Note: It maintains a tolerance of $\pm 10\%$ on luminous intensity

■ Wavelength :

Color	Spec. Range
R	620-625 nm
G	520-535 nm
B	460-472 nm

Note: It maintains a tolerance of $\pm 0.5\text{nm}$ on Wavelength Bin

Official Product	HT Part No. B3DK3BRG-12C000113E0118		
Tentative Product	*****	*****	*****
Specifications are subject to changes for improvement without advance notice. Proprietary data, drawings, company confidential all rights reserved.		10/22/2019	Preliminary Page 6/15

Product Features

Electro-Optical Characteristics

(T_{Soldering} 25 °C)

Series	Emitting Color	Material	Wavelength λ(nm)			I _v (mcd)	Viewing
			λ _D	λ _P	Δ λ	Typical	Angle $2\theta \frac{1}{2}$
B3DK3BRG	R	AllnGaP	624	630	18	181	120
	G	InGaN	523	518	35	350	120
	B	InGaN	470	465	25	78	120

Package Outline Dimension and Recommended Soldering Pattern for Reflow Soldering

(Unit:mm Tolerance: +/-0.1)

Outline Dim.	Soldering Pattern
<p>Top view dimensions: 2.00mm width, 2.00mm height. Pin locations: Pin3 DIN (IC), Pin4 GND, Pin1 DOUT, Pin2 VDD. Emitting colors G, R, B are shown. Side view shows a height of 0.90mm and a resin layer of 0.30mm. Pad dimensions: 0.60mm, 0.80mm, 0.60mm. Pin pad dimensions: 0.60mm, 0.80mm, 0.60mm.</p>	<p>Soldering pattern dimensions: Pin3 DIN (0.90mm x 0.80mm), Pin4 GND (0.90mm x 0.80mm), Pin1 DOUT (0.90mm x 0.80mm), Pin2 VDD (0.90mm x 0.80mm).</p>
Soldering terminals may shift in the x, y direction.	

Absolute Maximum Ratings (unless otherwise specified, Temperature=25°C)

(T_{Soldering} 25 °C)

Characteristic	Symbol	Rating	Unit
Supply Voltage	VDD	6.5	V
Power Dissipation	PD	<400	mW
Maximum Output Current	I _{LEDOUT}	5	mA
Welding Temperature	T _M	300(8S)	°C
Operating Temperature Range	T _{OPR}	-40~85	°C
Storage Temperature Range	T _{STO}	-65~120	°C

Official Product	HT Part No. B3DK3BRG-12C000113E0118		
Tentative Product	*****	*****	*****
Specifications are subject to changes for improvement without advance notice. Proprietary data, drawings, company confidential all rights reserved.	10/22/2019	Preliminary	Page 7/15

Electrical Characteristics

Parameter		Symbol	Min.	Typ.	Max.	Units	Note
Supply Voltage		VDD	4.5	5	5.5	V	
Operation Current		IDD			2	mA	R、G、B no load
Input High "H" of DI		VIH	2.7		VDD	V	
Input Low "L" of DI		VIL	0		1.0	V	
Pull Down Resistance		RPD		500K		Ω	DI、DO
Output High "H" of DO		VOH	4.5			V	IOH=4mA
Output Low "L" of DO		VOL			0.4	V	IOL=4mA
R、G、B Sink Current	AP6110-05	ISINK	4.75	5	5.25	mA	Vo=VDD-3.0V @VDD=5V
	AP6110-12		11.4	12	12.6	mA	
	AP6110-20		19	20	21	mA	
Input leakage		Ileak			1	uA	DI=VDD
R、G、B off leakage current		Ioff			1	uA	PWM=0(off), @R、G、B=5V

Parameter	Symbol	Min.	Typ.	Max.	Units	Note
Propagation delay time	tPLZ			300	ns	DI → DO, CL=15pF, RL=10KΩ
	tPZL			300	ns	
Rising time	tTZH			200	ns	R、G、B=20mA, CL=30pF
Falling time	tTHZ			200	ns	
Data rate	Fdata		800		Khz	

Official Product	HT Part No. B3DK3BRG-12C000113E0118		
Tentative Product	*****	*****	*****
Specifications are subject to changes for improvement without advance notice. Proprietary data, drawings, company confidential all rights reserved.		10/22/2019	Preliminary Page 8/15

Data Transfer Protocol

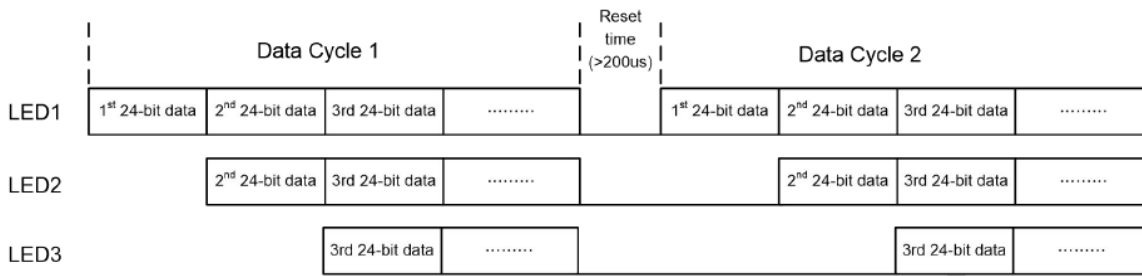

The single wire data transfer protocol supports 24-bit data for each LED RGB display data refresh. AP6110 receives 24-bit data and passes the remaining data to next LED. The 24-bit data consist of red, green and blue data, each with 8-bit width, and are transferred with MSB first.

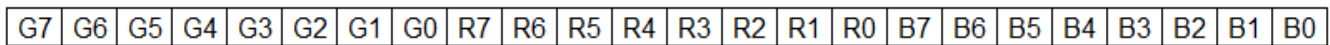

The transferred data are recognized based on the pulse widths received by AP6110. A low bit 0 is represented by a 0.3us high pulse followed by a 0.9us low pulse. A high bit 1 is represented by a 0.9us high pulse followed by a 0.3us low pulse. A low pulse \cong 200us is used to issue a reset command to AP6110-12 to start a new cycle of serial commands.

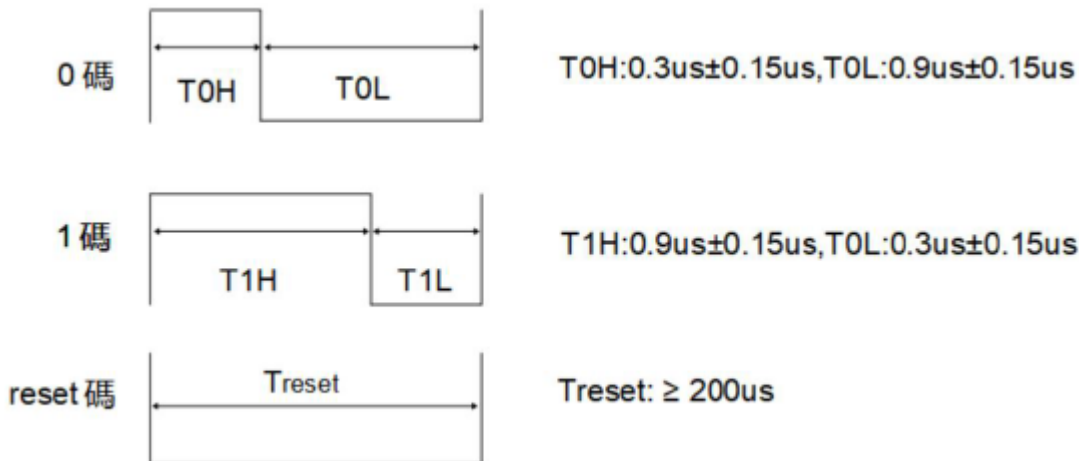

Official Product	HT Part No. B3DK3BRG-12C000113E0118		
Tentative Product	*****	*****	*****
Specifications are subject to changes for improvement without advance notice. Proprietary data, drawings, company confidential all rights reserved.	10/22/2019	Preliminary	Page 9/15

Precaution for Use

1. The chips should not be used directly in any type of fluid such as water, oil, organic solvent, etc.
2. When the LEDs are illuminating, the maximum ambient temperature should be first considered before operation.
3. LEDs must be stored in a clean environment. A sealed container with a nitrogen atmosphere is necessary if the storage period is over 3 months after shipping.
4. The LEDs must be used within 72hours after unpacked. Unused products must be repacked in an anti-electrostatic package, folded to close any opening and then stored in a dry and cool space.
5. The appearance and specifications of the products may be modified for improvement without further notice.
6. The LEDs are sensitive to the static electricity and surge. It is strongly recommended to use a grounded wrist band and anti-electrostatic glove when handling the LEDs. If a voltage over the absolute maximum rating is applied to LEDs, it will damage LEDs. Damaged LEDs will show some abnormal characteristics such as remarkable increase of leak current, lower turn-on voltage and getting unlit at low current.

Official Product	HT Part No. B3DK3BRG-12C000113E0118		
Tentative Product	*****	*****	*****
Specifications are subject to changes for improvement without advance notice. Proprietary data, drawings, company confidential all rights reserved.		10/22/2019	Preliminary Page 10/15

Packaging Tape Dimension

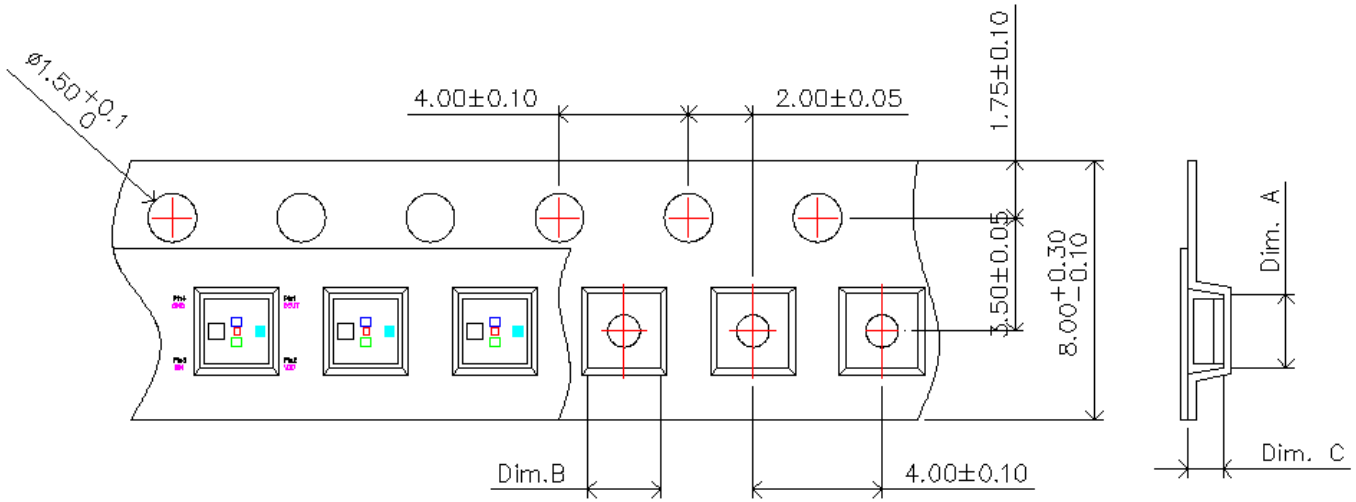

Dim. A	Dim. B	Dim. C	Q'ty/Reel
2.15±0.10	2.15±0.10	1.05±0.10	3K

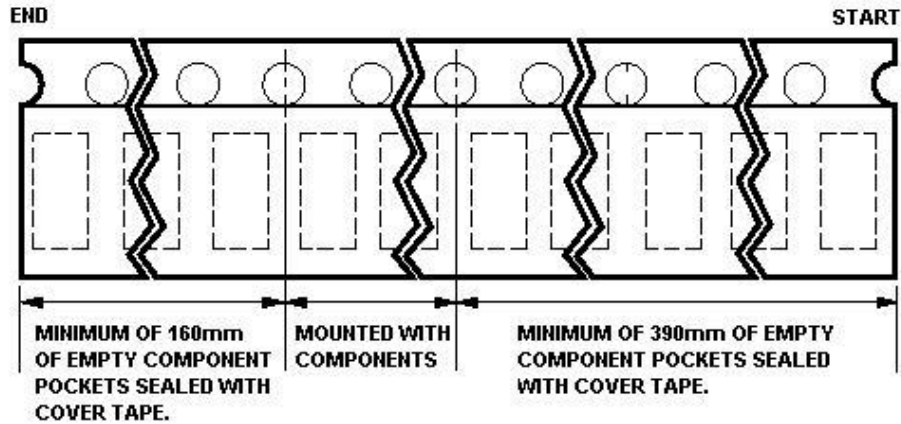

Official Product	HT Part No. B3DK3BRG-12C000113E0118		
Tentative Product	*****	*****	
Specifications are subject to changes for improvement without advance notice. Proprietary data, drawings, company confidential all rights reserved.		10/22/2019	Preliminary Page 11/15

Reel Dimension

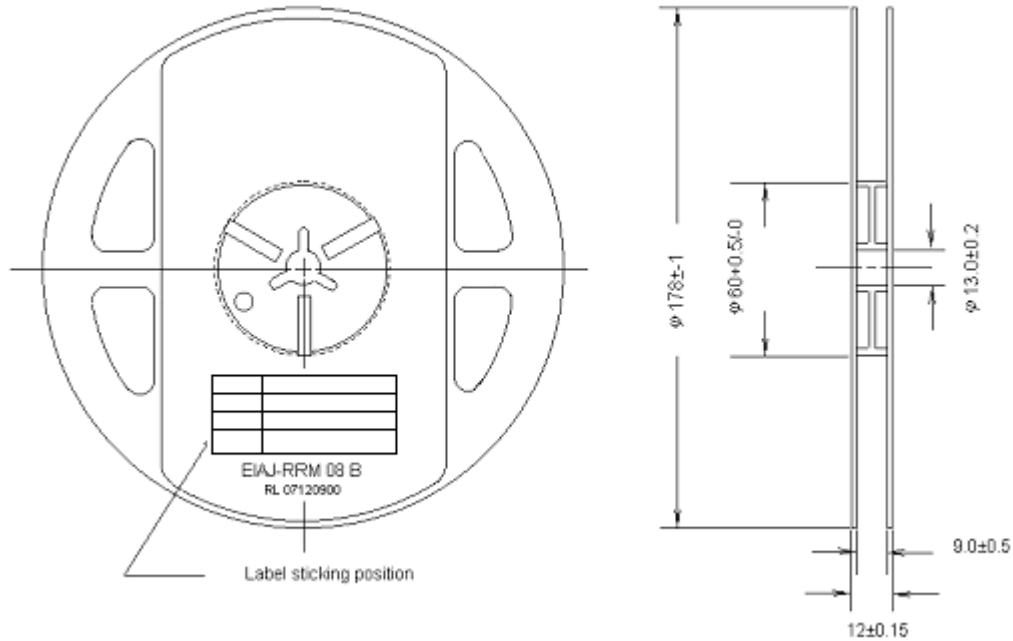

Packing

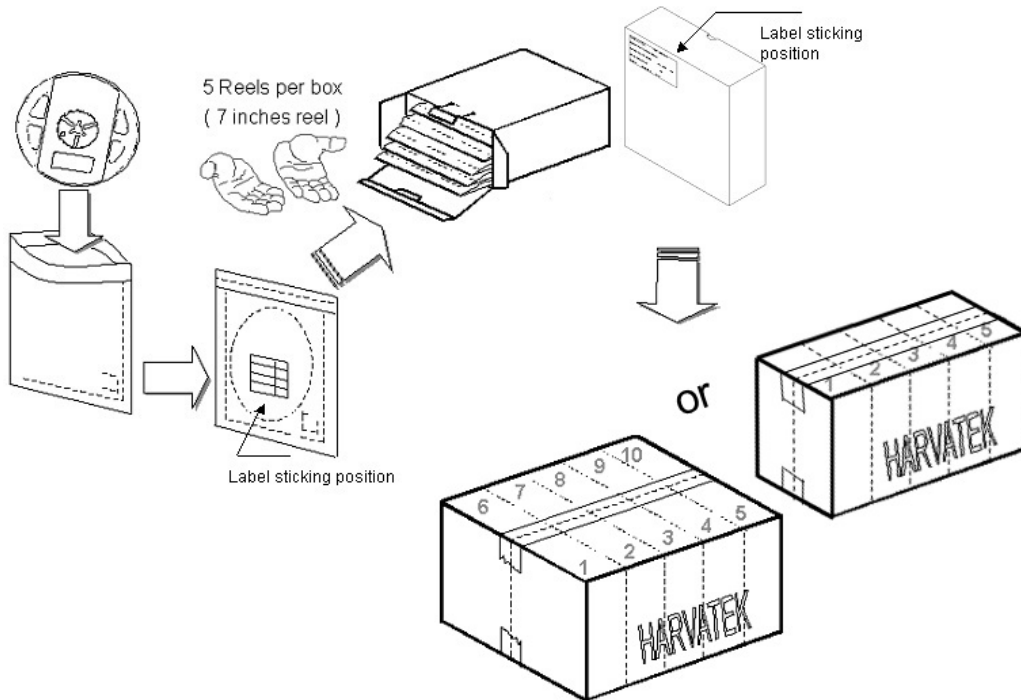

5 or 10 boxes per carton is available depending on shipment quantity.

Official Product	HT Part No. B3DK3BRG-12C000113E0118		
Tentative Product	*****	*****	*****
Specifications are subject to changes for improvement without advance notice. Proprietary data, drawings, company confidential all rights reserved.		10/22/2019	Preliminary Page 12/15

Dry Pack

All SMD optical devices are **MOISTURE SENSITIVE**. Avoid exposure to moisture at all times during transportation or storage. Every reel is packaged in a moisture protected anti-static bag. Each bag is properly sealed prior to shipment.

A humidity indicator will be included in the moisture protected anti-static bag prior to shipment.

The packaging sequence is as follows:

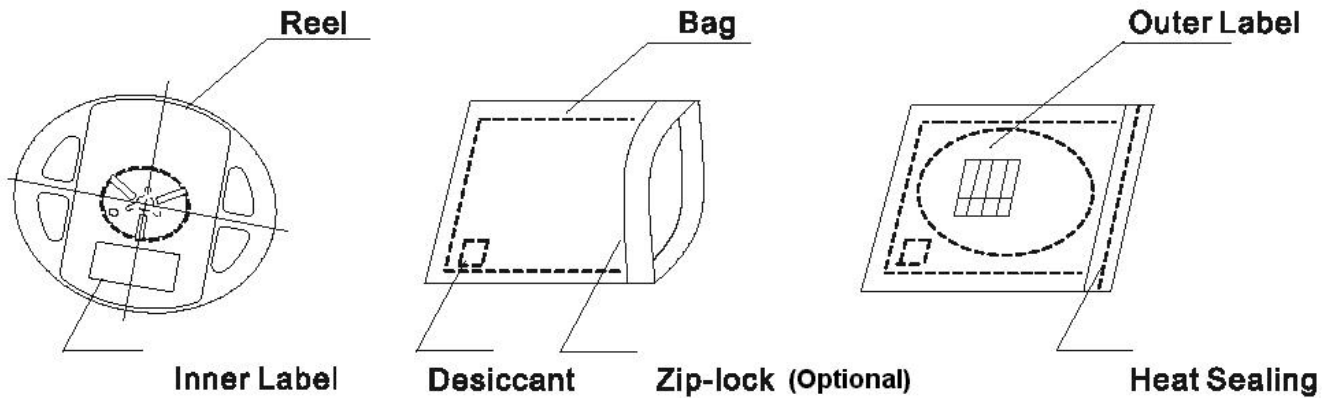

Baking

Baking before soldering is recommended when the package has been unsealed for 72hours.

The conditions are as followings:

1. $60\pm 3^{\circ}\text{C} \times (12\sim 24\text{hrs})$ and $< 5\% \text{RH}$, taped reel type.
2. $100\pm 3^{\circ}\text{C} \times (45\text{min}\sim 1\text{hr})$, bulk type.
3. $130\pm 3^{\circ}\text{C} \times (15\text{min}\sim 30\text{min})$, bulk type.

Precautions

1. Avoid exposure to moisture at all times during transportation or storage.
2. Anti-Static precaution must be taken when handling GaN, InGaN, and AlInGaP products.
3. It is suggested to connect the unit with a current limiting resistor of the proper size. Avoid applying a reverse voltage beyond the specified limit.
4. Avoid operation beyond the limits as specified by the absolute maximum ratings.
5. Avoid direct contact with the surface through which the LED emits light.
6. If possible, assemble the unit in a clean room or dust-free environment.

Official Product	HT Part No. B3DK3BRG-12C000113E0118		
Tentative Product	*****	*****	*****
Specifications are subject to changes for improvement without advance notice. Proprietary data, drawings, company confidential all rights reserved.	10/22/2019	Preliminary	Page 13/15

Reflow Soldering

Recommend soldering paste specifications:

1. Operating temp.: Above 220°C ,60 sec.
2. Peak temp.:260 °C Max.,10sec Max.
3. Reflow soldering should not be done more than two times.
4. Never attempt next process until the component is cooled down to room temperature after reflow.
5. The recommended reflow soldering profile (measured on the surface of the LED terminal) is as following:

Lead-free Solder Profile

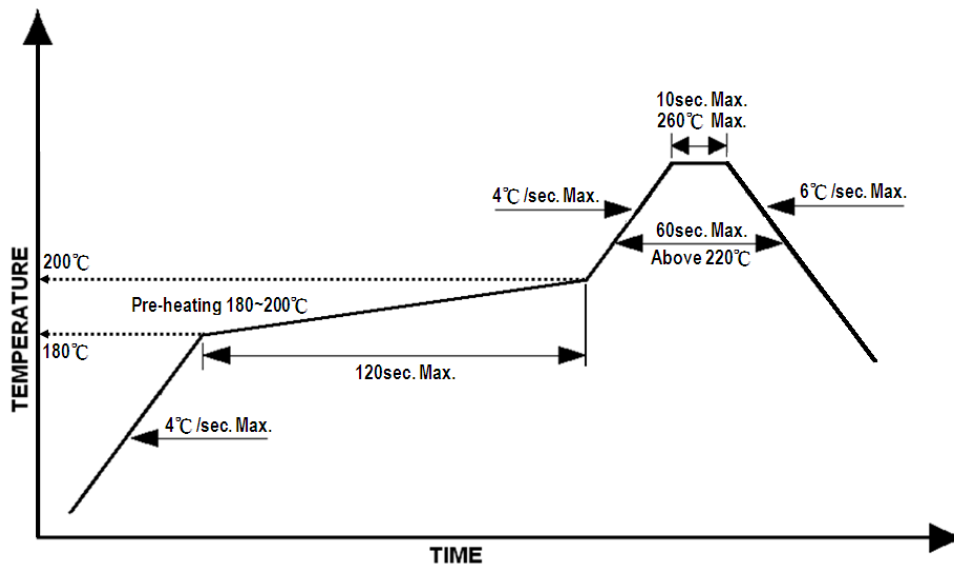

Reworking

- Rework should be completed within 5 seconds under 260 °C .
- The iron tip must not come in contact with the copper foil.
- Twin-head type is preferred.

Cleaning

Following are cleaning procedures after soldering:

- An alcohol-based solvent such as isopropyl alcohol (IPA) is recommended.
- Temperature x Time should be 50°C x 30sec. or <30°C x 3min
- Ultrasonic cleaning: < 15W/ bath; bath volume ≤ 1liter
- Curing: 100 °C max, <3min

Official Product	HT Part No. B3DK3BRG-12C000113E0118		
Tentative Product	*****	*****	*****
Specifications are subject to changes for improvement without advance notice. Proprietary data, drawings, company confidential all rights reserved.	10/22/2019	Preliminary	Page 14/15

Cautions of Pick and Place

- Avoid stress on the resin at elevated temperature.
- Avoid rubbing or scraping the resin by any object.
- Electric-static may cause damage to the component. Please ensure that the equipment is properly grounded. Use of an ionizer fan is recommended.

Revise History

Rev.	Descriptions	Date	Page
-	-	10/22/2019	-

Official Product	HT Part No. B3DK3BRG-12C000113E0118		
Tentative Product	*****	*****	*****
Specifications are subject to changes for improvement without advance notice. Proprietary data, drawings, company confidential all rights reserved.		10/22/2019	Preliminary Page 15/15