



**RAYSTAR**

# 曜凌光電股份有限公司

住址: 42878 台中市大雅区科雅路 25 號 5F WEB: <http://www.Raystar-Optronics.com>  
5F., No.25, Keya Rd., Daya Dist., Taichung E-mail: [sales@raystar-optronics.com](mailto:sales@raystar-optronics.com)  
City 428, Taiwan Tel:886-4-2565-0761 Fax : 886-4-2565-0760

## RFC350R-AIW-DNN

---

---

### SPECIFICATION

CUSTOMER:

APPROVED BY	
PCB VERSION	
DATE	

FOR CUSTOMER USE ONLY

SALES BY	APPROVED BY	CHECKED BY	PREPARED BY

Release DATE:

## Revision History

VERSION	DATE	REVISED PAGE NO.	Note
0	2016/01/14		First issue
A	2016/01/21		Modify Static electricity test
B	2016/08/11		Modify Vibration test
C	2016/10/17		Modify Summary
D	2017/03/31		Add Aspect Ratio

RAYSTAR OPTRONICS

# Contents

1. Module Classification Information
2. Summary
3. General Specification
4. Interface
5. Contour Drawing
6. Block Diagram
7. Absolute Maximum Ratings
8. Electrical Characteristics
9. AC Characteristics
10. Optical Characteristics
11. Reliability
12. Other



## 2.Summary

TFT 3.5" is a TN transmissive type color active matrix TFT liquid crystal display that use amorphous silicon TFT as switching devices. This module is a composed of a TFT\_LCD module, It is usually designed for industrial application and this module follows RoHs,

RAYSTAR OPTRONICS

---

### 3.General Specifications

- Size: 3.5 inch
- Dot Matrix: 320 x RGBx240(TFT) dots
- Module dimension: 76.84(W) x 63.84(H) x 3.27(D) mm
- Active area: 70.08 x 52.56 mm
- Dot pitch: 0.073 x 0.219 mm
- LCD type: TFT, Normally White, Transmissive
- View Direction: 12 o'clock
- Gray Scale Inversion Direction: 6 o'clock
- Aspect Ratio: 4:3
- Backlight Type: LED, Normally White
- IC: SSD2119
- With /Without TP: Without TP
- Surface: Anti-Glare

\*Color tone slight changed by temperature and driving voltage.

## 4.Interface

### 4.1. LCM PIN Definition

No.	Symbol	Description
1	VCI	Booster input voltage pin
2	VCI	Booster input voltage pin
3	VSS	Ground
4	VDDIO	Voltage input pin for logic
5	VSS	Ground
6	RESET	Reset Signal pin ("Low" is enable)
7	DC/SDC	Data or Command select PIN.
8	E/RD	6800 system: E(enable signal) 8080 system : RD(read strobe signal) Serial mode: Not use and should be connected to VDDIO or VSS
9	WR	6800 system : RW (indicates read cycle when high ,write cycle when low) 8080 system : WR (write strobe signal)
10	CS	Chip select
11	SCL	Serial Clock.
12	SD0	Serial Data output
13	SDI	Serial Data Input
14	WSYNC	Ram write synchronization output. Leave it OPEN when not used.
15~32	D17~D0	Data bus
33	VSS	Ground
34	DOTCLK	Dot-clock signal and oscillator source
35	HSYNC	Line Synchronous Signal
36	VSYNC	Frame Synchronous Signal
37	DE	Display enable pin for controller
38	VSS	Ground
39	PS0	Interface select PIN
40	PS1	
41	PS2	
42	PS3	
43	VSS	Ground
44~47	NC	NC
48	VSS	Ground
49	LEDK	Backlight LED Cathode
50	LEDA	Backlight LED Anode.

<b>PS3</b>	<b>PS2</b>	<b>PS1</b>	<b>PS0</b>	<b>Interface Mode</b>	<b>Data bus input</b>
0	0	0	0	16-bit 6800 parallel interface	D[17:10], D[8:1]
0	0	0	1	8-bit 6800 parallel interface	D[17:10]
0	0	1	0	16-bit 8080 parallel interface	D[17:10], D[8:1]
0	0	1	1	8-bit 8080 parallel interface	D[17:10]
0	1	0	0	9-bit generic D[9:16] (262k colour) + 3-wire SPI If 65K color, D12 shorts to D17 internally	
0	1	0	1	16-bit generic (262k colour) + 3-wire SPI	
0	1	1	0	18-bit generic (262k colour) + 3-wire SPI	
0	1	1	1	6-bit generic D[8:3] (262k colour) + 3-wire SPI	
1	0	0	0	18-bits 6800 parallel interface	D[17:0]
1	0	0	1	9-bits 6800 parallel interface	D[17:9]
1	0	1	0	18-bit 8080 parallel interface	D[17:0]
1	0	1	1	9-bit 8080 parallel interface	D[17:9]
1	1	1	0	3-wire SPI	
1	1	1	1	4-wire SPI	

RAYSTAR



# 5. Contour Drawing

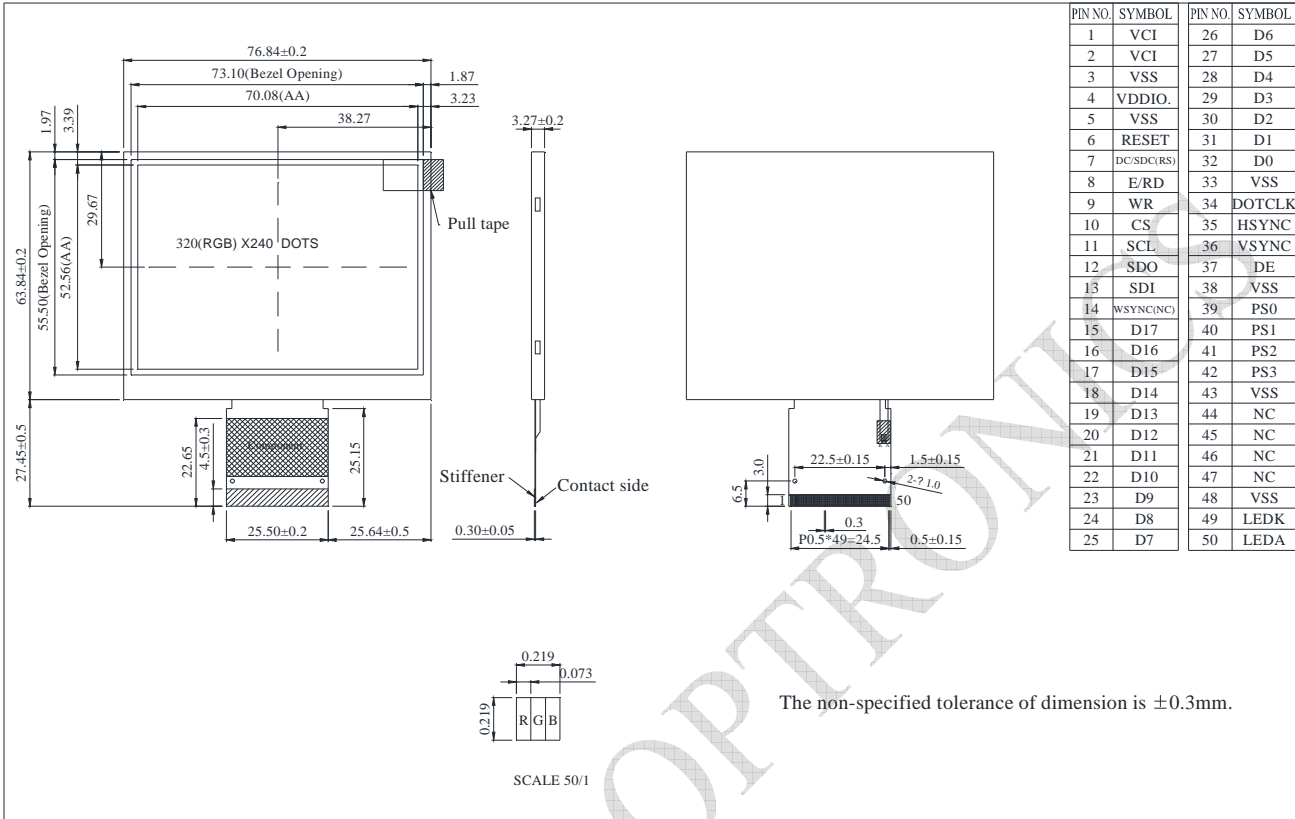

## 6. Block Diagram

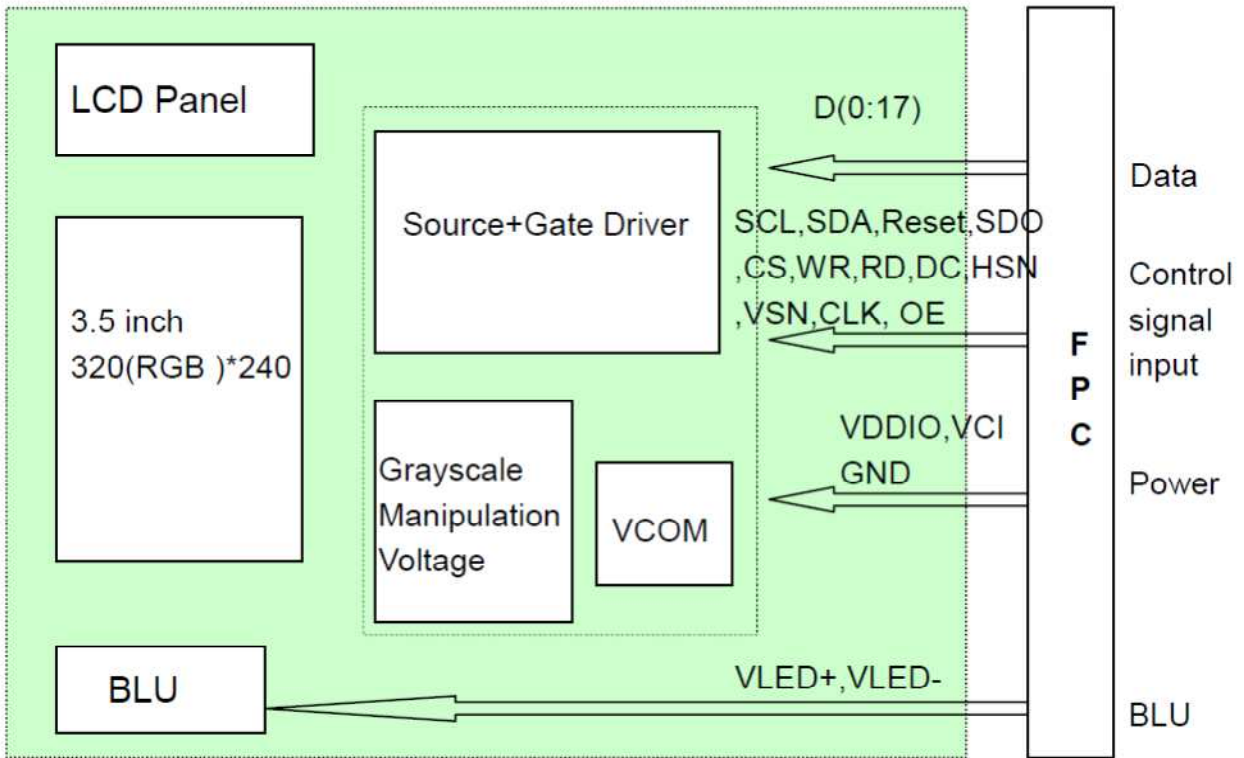

RAYSTAR

## 7. Absolute Maximum Ratings

Item	Symbol	Min	Typ	Max	Unit
Operating Temperature	TOP	-20	—	+70	°C
Storage Temperature	TST	-30	—	+80	°C

Note: Device is subject to be damaged permanently if stresses beyond those absolute maximum ratings listed above

- Temp.  $\leq 60^{\circ}\text{C}$ , 90% RH MAX. Temp.  $> 60^{\circ}\text{C}$ , Absolute humidity shall be less than 90% RH at  $60^{\circ}\text{C}$

RAYSTAR OPTRONICS

## 8. Electrical Characteristics

### 8.1. Operating conditions:

Item	Symbol	MIN	TYP	MAX	Unit	Remark
Power supply voltage	VCI	2.5	3.3	3.6	V	
Power supply pin of IO pins	VDDIO	1.4	3.3	3.6	V	
Current consumption	IVCI+IVDDIO	-	-	10	mA	
Dot clock	DCK	-	5.5	8.2	MHz	

### 8.2. LED driving conditions

Item	Symbol	MIN	TYP	MAX	Unit	Remark
Forward Current	IF	-	20	-	mA	
Forward Voltage	VF	18	19.6	20.4	V	
Backlight Power consumption	WBL	-	0.384	0.495-	W	
LED Lifetime			25000		Hrs	

Note 1 : There are 1 Groups LED

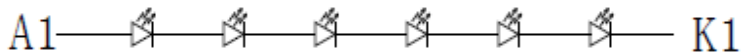

Note 2 : Ta = 25 °C

Note 3 : Brightness to be decreased to 50% of the initial value

Note 4 : The single LED lamp case

## 9.AC Characteristics

### 9.1. Parallel 6800-series Interface Timing Characteristics

Symbol	Parameter	Min	Typ	Max	Unit
t <sub>cycle</sub>	Clock cycle time (write cycle)	75	-	-	ns
t <sub>cycle</sub>	Clock cycle time (read cycle)	1000	-	-	ns
t <sub>AS</sub>	Address setup time (R/W)	0	-	-	ns
t <sub>AH</sub>	Address hold time (R/W)	0	-	-	ns
t <sub>DSW</sub>	Data setup time(D0~D7,WRITE)	5	-	-	ns
t <sub>DHW</sub>	Data hold time(D0~D7,WRITE)	5	-	-	ns
t <sub>ACC</sub>	Data access time(D0~D7,READ)	250	-	-	ns
t <sub>OH</sub>	Output hold time(D0~D7,READ)	100	-	-	ns
PW <sub>CSL</sub>	Pulse width/CS low(write cycle)	40	-	-	ns
PW <sub>CSH</sub>	Pulse width/CS high(write cycle)	25	-	-	ns
PW <sub>CSL</sub>	Pulse width/CS low(read cycle)	500	-	-	ns
PW <sub>CSH</sub>	Pulse width/CS high(read cycle)	500	-	-	ns
t <sub>R</sub>	Rise time(/CS)	-	-	4	ns
t <sub>F</sub>	Fall time(/CS)	-	-	4	ns

Note: CS can be pulled low during the write cycle, only /RW is needed to be toggled  
 Parallel 6800-series interface timing characteristics

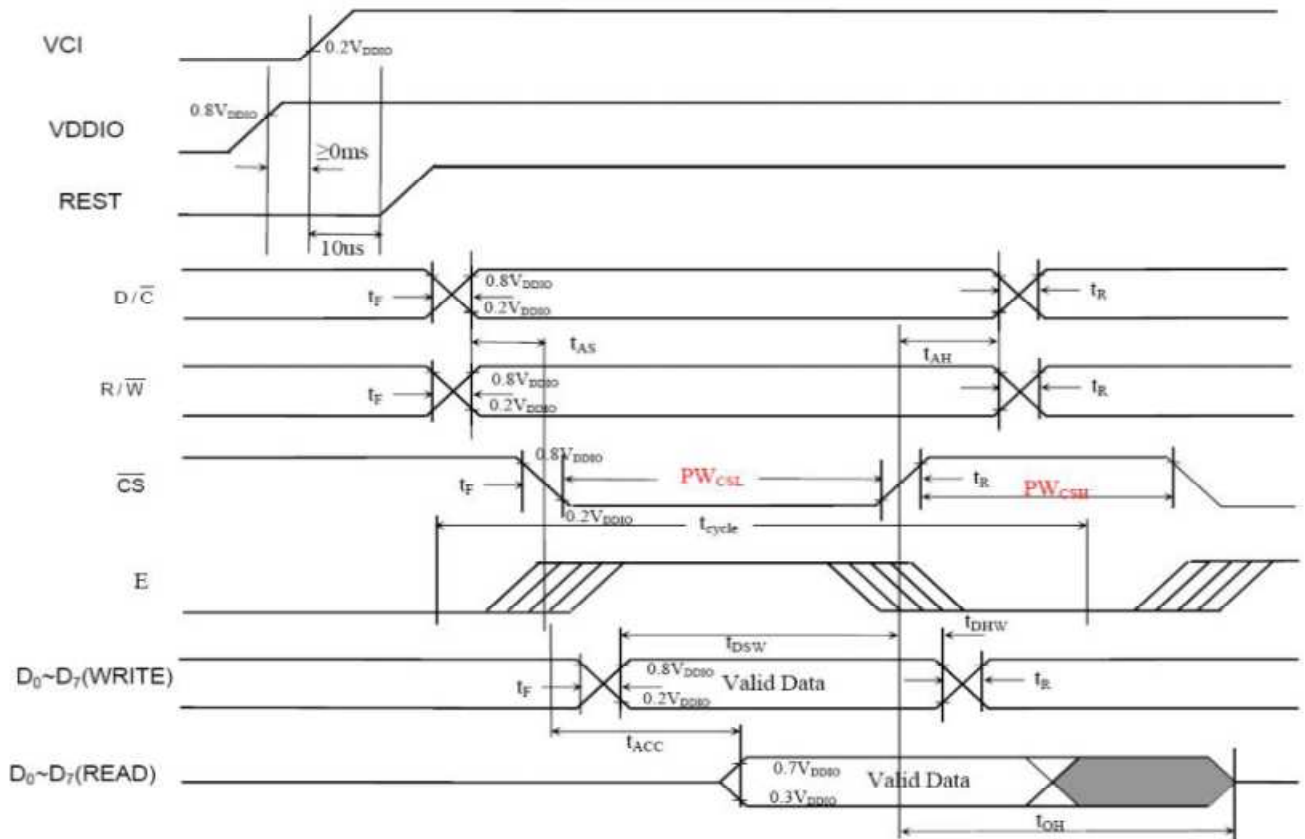

**9.2. Parallel 800 Timing Characteristics**

Symbol	Parameter	Min	Typ	Max	Unit
tcycle	Clock cycle time (write cycle)	100	-	-	ns
tAS	Address setup time	10	-	-	ns
tAH	Address hold time	0	-	-	ns
tCS	Chip select time	0			ns
tCH	Chip select hold time	0			ns
tDSW	Write Data setup time	10	-	-	ns
tDHW	Write Data hold time	10	-	-	ns
tDHR	Read Data hold time	100			ns
tACC	Access time(RAM)	250	-	-	ns
	Access time(command)	250			ns
tPWLR	Chip select low pulse width(read RAM)	500			ns
tPWLR	Chip select low pulse width(read command)	500	-	-	ns
tPWLW	Chip select low pulse width(write)	50			ns
tPWHR	Chip select high pulse width(read)	500	-	-	ns
tPWHW	Chip select high pulse width(write)	50			ns
tR	Rise time	-	-	15	ns
tF	Fall time	-	-	15	ns

Note: all timings are based on 20% to 80% of VDDIO-VSS

8080-series parallel interface characteristics(Form 1: /CS low pulse width > W/R low pulse width)

**Write Cycle**

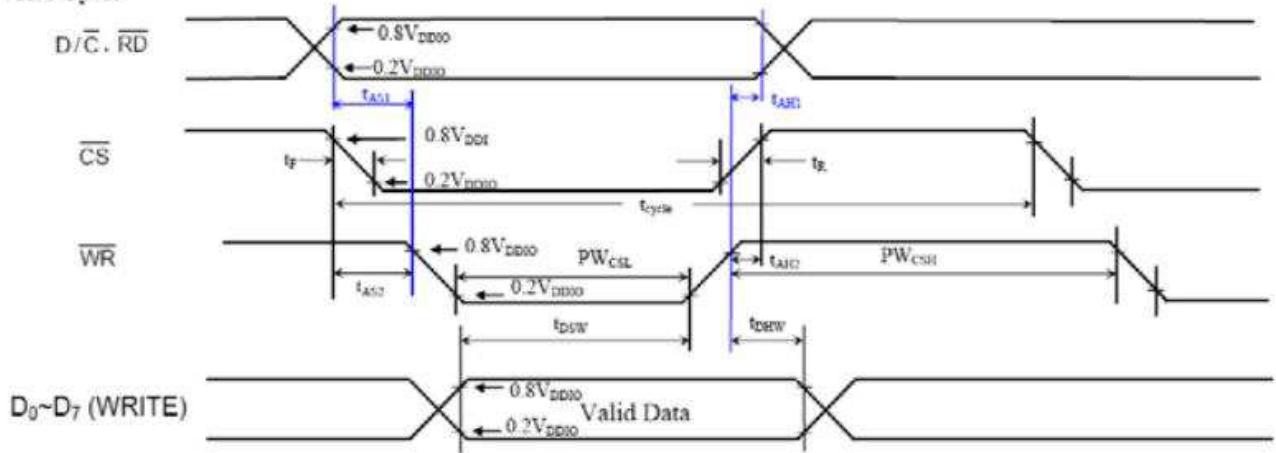

Remark: It's highly recommended that  $\overline{RD}$  remains high for the whole write cycle

**Read Cycle**

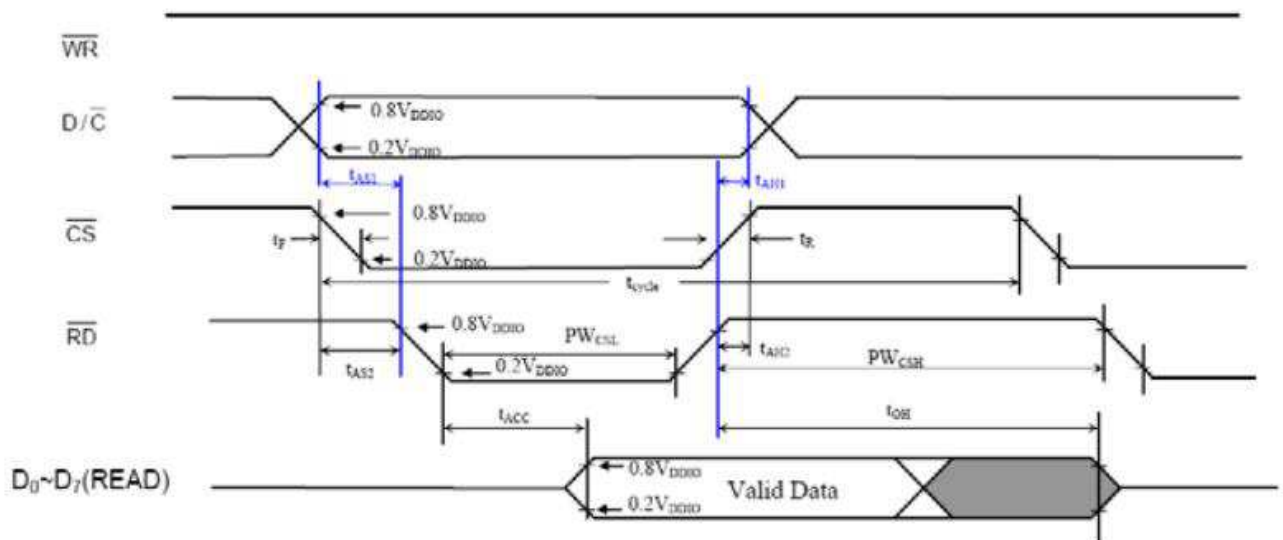

RAYSTAR

9.3. Serial Timing Characteristics

(Ta=-40 to 85°C, VDDIO = 1.4V to 3.6V)

Symbol	Parameter	Min	Typ	Max	Unit
t <sub>cycle</sub>	Clock cycle time	77	-	-	ns
f <sub>CLK</sub>	Serial clock cycle time SPI clock tolerance = +/- 2 ppm	-	-	15	MHz
t <sub>AS</sub>	Register select setup time	4	-	-	ns
t <sub>AH</sub>	Register select hold time	5	-	-	ns
t <sub>CSS</sub>	Chip select setup time	2	-	-	ns
t <sub>CSH</sub>	Chip select hold time	10	-	-	ns
t <sub>DSW</sub>	Write Data setup time	5	-	-	ns
t <sub>OHW</sub>	Write Data hold time	10	-	-	ns
t <sub>CLKL</sub>	Clock low time	38	-	-	ns
t <sub>CLKH</sub>	Clock high time	38	-	-	ns
t <sub>R</sub>	Rise time	-	-	4	ns
t <sub>F</sub>	Fall time	-	-	4	ns

4 wire serial timing characteristics

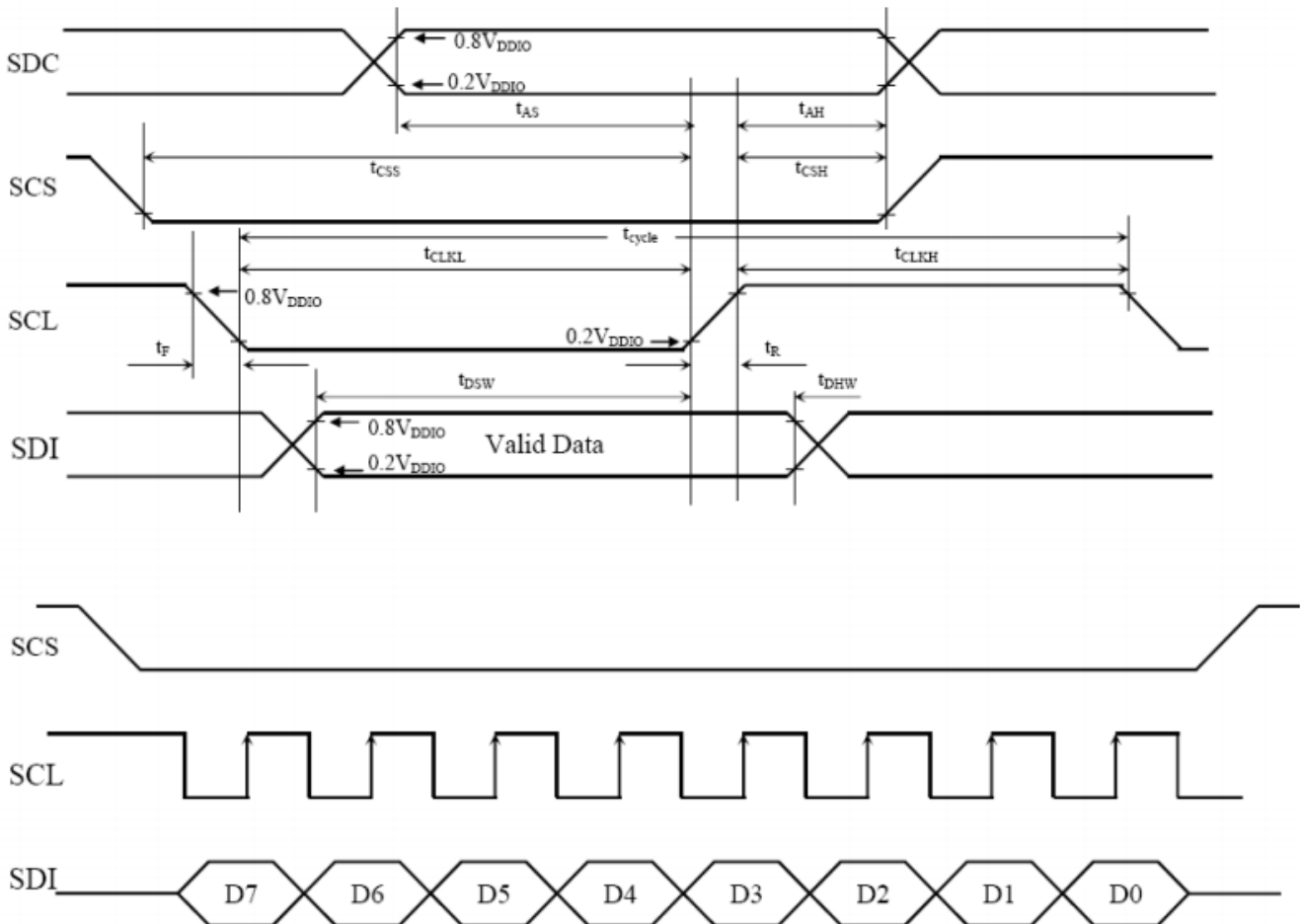



**9.4. RGB Timing Characteristics**

( $T_a = -40$  to  $85^\circ\text{C}$ ,  $V_{DDIO} = 1.4\text{V}$  to  $3.6\text{V}$ )

Symbol	Parameter	Min	Typ	Max	Unit
fDOTCLK	DOTCLK frequency (70Hz frame rate)	1	5.5	8.2	ns
tDOTCLK	DOTCLK period	122	182	1000	ns
tVSYN	Vertical sync setup time	20	-	-	ns
tVSYH	Vertical sync hold time	20	-	-	ns
tHSYS	Horizontal sync setup time	20	-	-	ns
tHSYH	Horizontal sync hold time	20	-	-	ns
tHV	Phase difference of sync signal falling edge	0	-	320	ns
tCLK	DOTCLK low period	61	-	-	ns
tCKH	DOTCLK high period	61	-	-	ns
tDS	Data setup time	25	-	-	ns
tDH	Data hold time	25	-	-	ns
tRES	Reset pulse width	8	-	-	ns

Note: external clock source must be provided to DOTCLK pin of SSD2119. The driver will not operate in absence of the clocking signal.

RGB timing characteristics

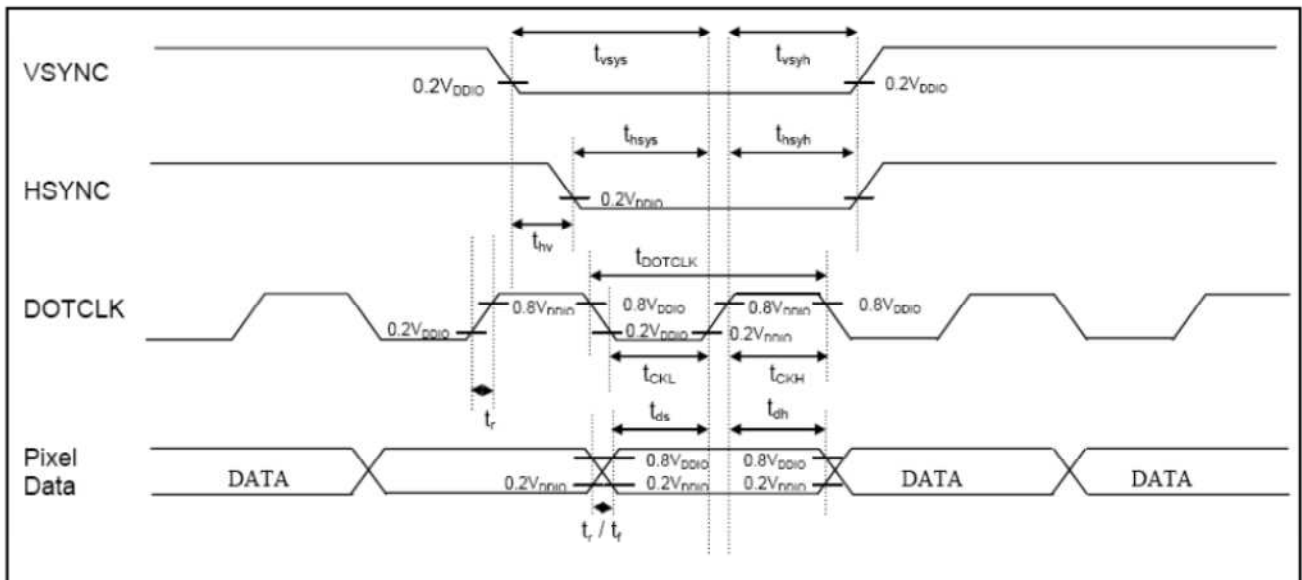

9.5. Power on sequence

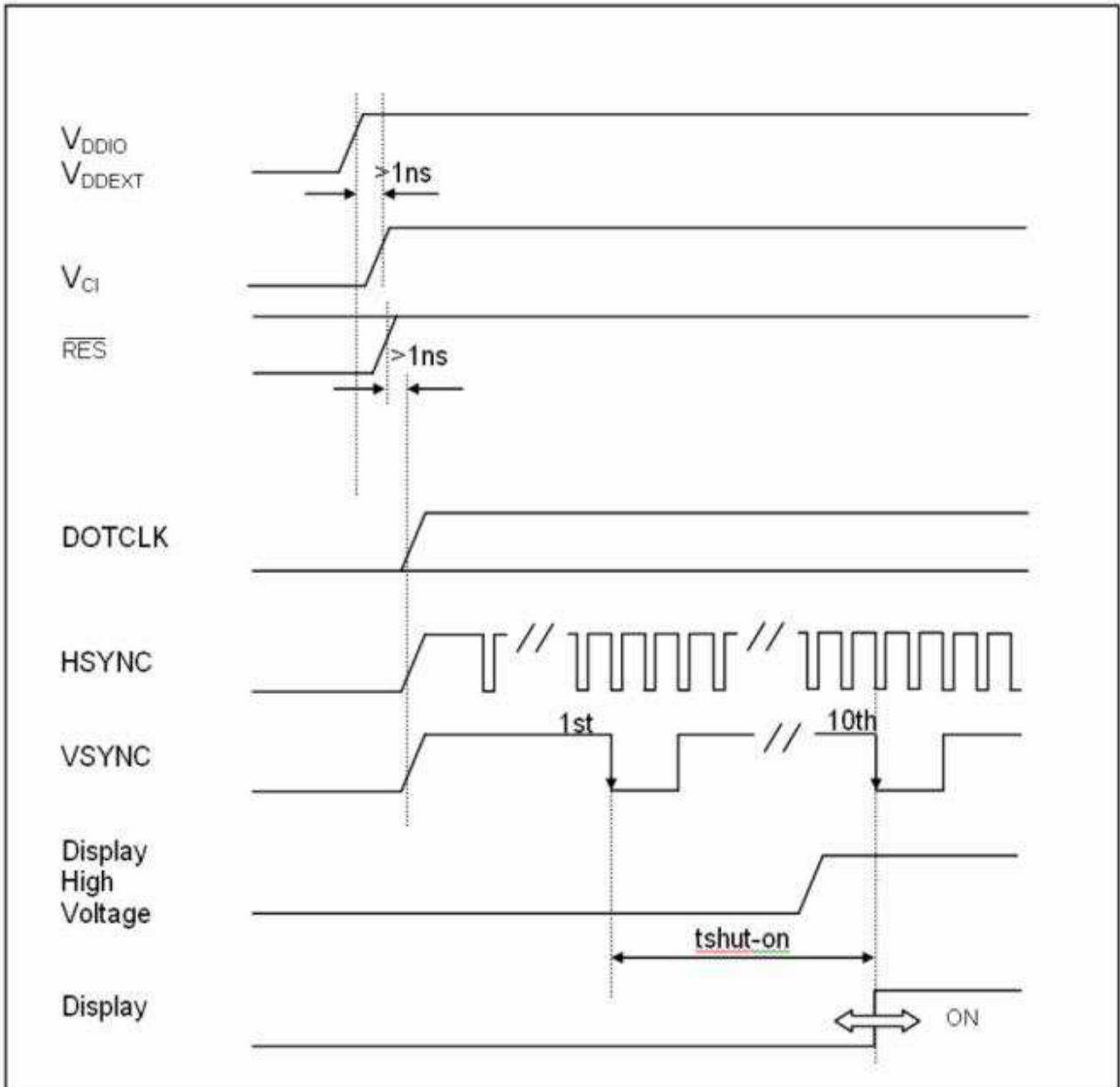

RAYSTAR

### 9.6. Display on sequence

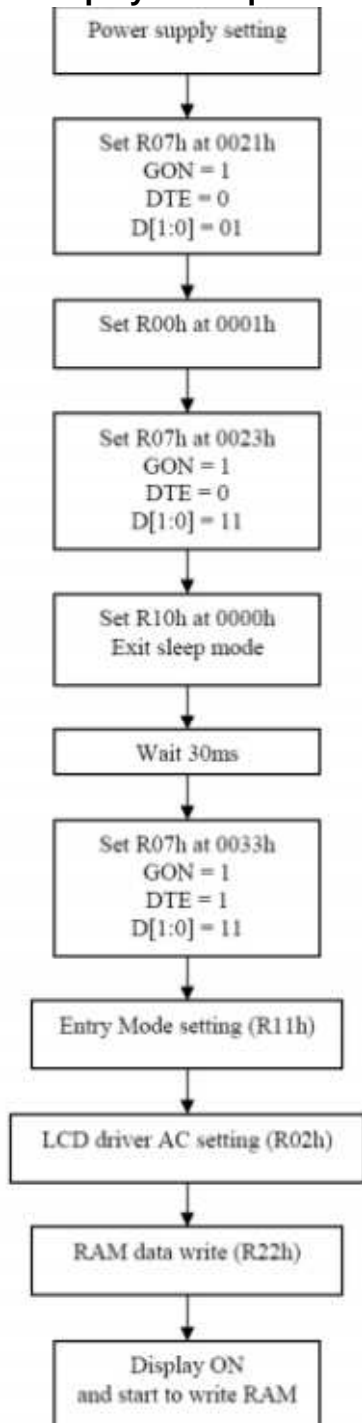

AR OPTRONICS

9.7. Display off sequence

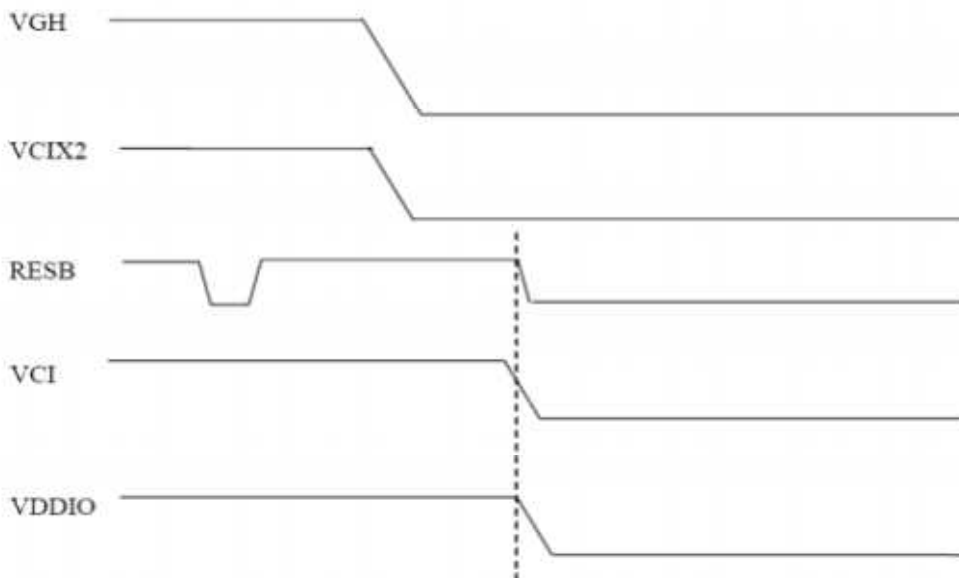
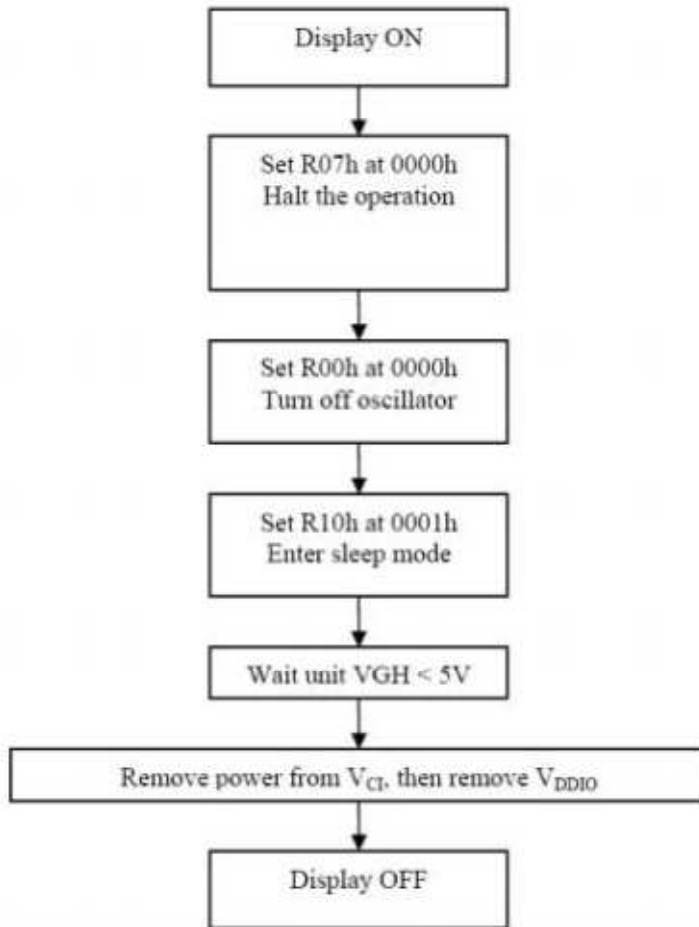

Note:  
 1. VDDIO should be the last to fall, or VCI/VDDIO could be power off at the same time  
 2. If OTP is active in the application, the OTP programming voltage should be turned off and cap

9.8.

Sleep mode display sequence

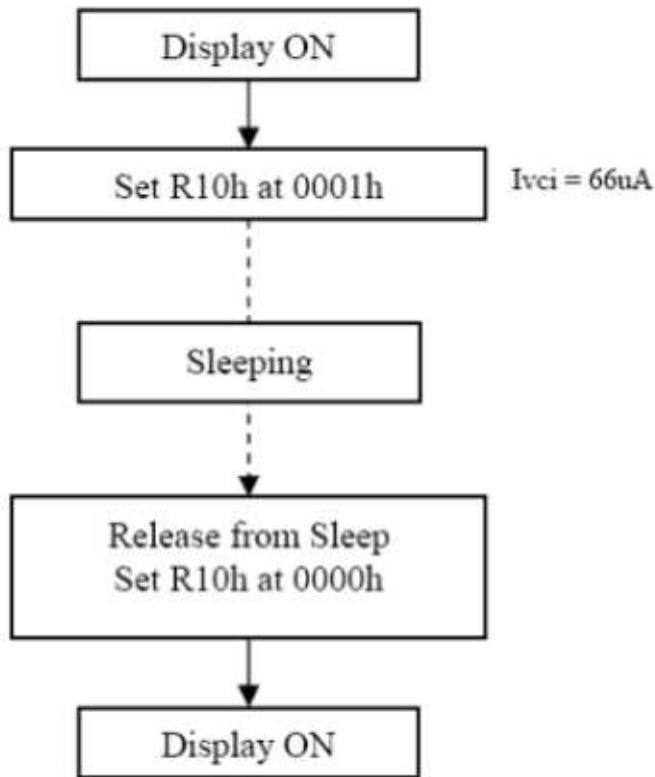

RAYSTAR ELECTRONICS

## 10. Optical Characteristics

Item	Symbol	Condition.	Min	Typ.	Max.	Unit	Remark	
Response time	Tr	$\theta=0^\circ \cdot \Phi=0^\circ$	-	8	12	ms	Note 3,5	
	Tf		-	17	23	ms		
Contrast ratio	CR	At optimized viewing angle	320	400	-	-	Note 4,5	
Color Chromaticity	White	Wx	$\theta=0^\circ \cdot \Phi=0^\circ$	0.285	0.305	0.325	-	Note 2,6,7
		Wy		0.314	0.334	0.354	-	
Viewing angle	Hor.	$\Theta_R$	CR $\geq 10$	60	70	-	Deg.	Note 1
		$\Theta_L$		60	70	-		
	Ver.	$\Phi_T$		45	60	-		
		$\Phi_B$		60	70	-		
Brightness	-	-	360	400	-	Cd/m <sup>2</sup>	Center of display	

Ta=25±2°C, IL=20mA

Note 1: Definition of viewing angle range

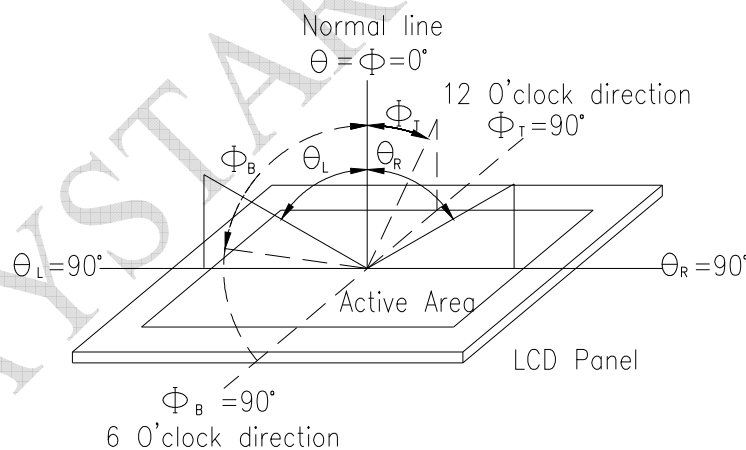

Fig. 10.1. Definition of viewing angle

Note 2: Test equipment setup:

After stabilizing and leaving the panel alone at a driven temperature for 10 minutes, the measurement should be executed. Measurement should be executed in a stable, windless, and dark room. Optical specifications are measured by Topcon BM-7orBM-5 luminance meter 1.0° field of view at a distance of 50cm and normal direction.

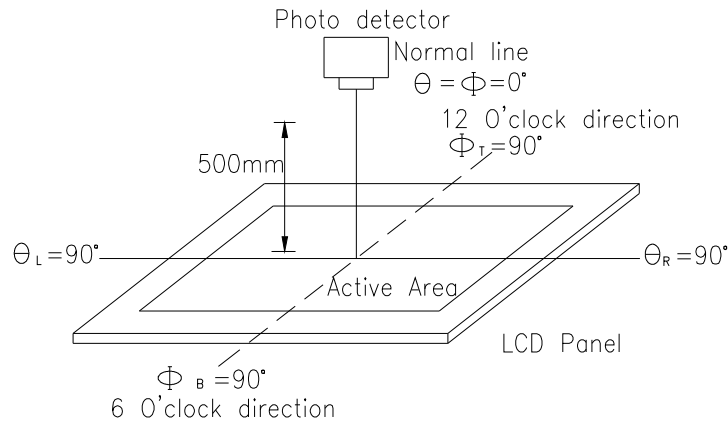
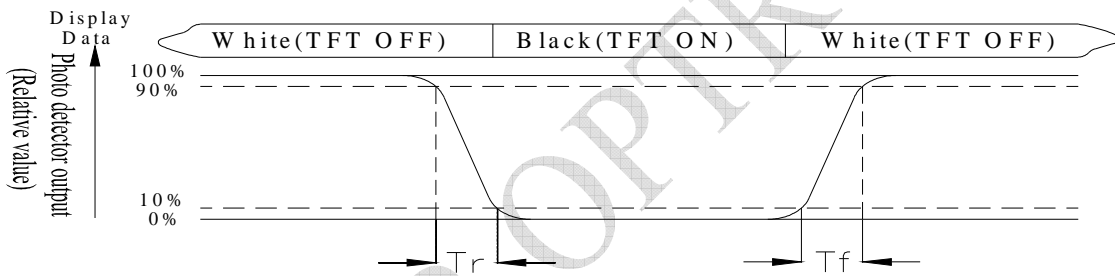

Fig. 10.2. Optical measurement system setup

Note 3: Definition of Response time:

The response time is defined as the LCD optical switching time interval between “White” state and “Black” state. Rise time,  $T_r$ , is the time between photo detector output intensity changed from 90% to 10%. And fall time,  $T_f$ , is the time between photo detector output intensity changed from 10% to 90%



Note 4: Definition of contrast ratio:

The contrast ratio is defined as the following expression.

$$\text{Contrast ratio (CR)} = \frac{\text{Luminance measured when LCD on the "White" state}}{\text{Luminance measured when LCD on the "Black" state}}$$

Note 5: White  $V_i = V_{i50} \pm 1.5V$

Black  $V_i = V_{i50} \pm 2.0V$

“±” means that the analog input signal swings in phase with VCOM signal.

“±” means that the analog input signal swings out of phase with VCOM signal.

The 100% transmission is defined as the transmission of LCD panel when all the input terminals of module are electrically opened.

Note 6: Definition of color chromaticity (CIE 1931)

Color coordinates measured at the center point of LCD

Note 7: Measured at the center area of the panel when all the input terminals of LCD panel are electrically opened.

# 11. Reliability

Content of Reliability Test (Wide temperature, -20°C~70°C)

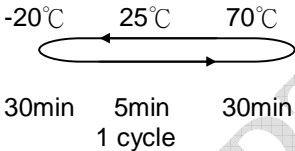
Environmental Test			
Test Item	Content of Test	Test Condition	Note
High Temperature storage	Endurance test applying the high storage temperature for a long time.	80°C 200hrs	2
Low Temperature storage	Endurance test applying the low storage temperature for a long time.	-30°C 200hrs	1,2
High Temperature Operation	Endurance test applying the electric stress (Voltage & Current) and the thermal stress to the element for a long time.	70°C 200hrs	—
Low Temperature Operation	Endurance test applying the electric stress under low temperature for a long time.	-20°C 200hrs	1
High Temperature/ Humidity Operation	The module should be allowed to stand at 60°C,90%RH max	60°C,90%RH 96hrs	1,2
Thermal shock resistance	The sample should be allowed stand the following 10 cycles of operation  <div style="text-align: center;">  <p>-20°C    25°C    70°C</p> <p>30min    5min    30min</p> <p>1 cycle</p> </div>	-20°C/70°C 10 cycles	—
Vibration test	Endurance test applying the vibration during transportation and using.	Total fixed amplitude : 3 1.5mm Vibration Frequency : 10~55Hz One cycle 60 seconds to 3 directions of X,Y,Z for Each 15 minutes	3
Static electricity test	Endurance test applying the electric stress to the terminal.	VS=±600V(contact) ,±800v(air), RS=330Ω CS=150pF 10 times	—

Note1: No dew condensation to be observed.

Note2: The function test shall be conducted after 4 hours storage at the normal Temperature and humidity after remove from the test chamber.

Note3: The packing have to including into the vibration testing.



**LCM Sample Estimate Feedback Sheet**

**Module Number :** \_\_\_\_\_

**1 、 Panel Specification :**

1. Panel Type :	<input type="checkbox"/> Pass	<input type="checkbox"/> NG , _____
2. View Direction :	<input type="checkbox"/> Pass	<input type="checkbox"/> NG , _____
3. Numbers of Dots :	<input type="checkbox"/> Pass	<input type="checkbox"/> NG , _____
4. View Area :	<input type="checkbox"/> Pass	<input type="checkbox"/> NG , _____
5. Active Area :	<input type="checkbox"/> Pass	<input type="checkbox"/> NG , _____
6. Operating Temperature :	<input type="checkbox"/> Pass	<input type="checkbox"/> NG , _____
7. Storage Temperature :	<input type="checkbox"/> Pass	<input type="checkbox"/> NG , _____
8. Others :	_____	

**2 、 Mechanical Specification :**

1. PCB Size :	<input type="checkbox"/> Pass	<input type="checkbox"/> NG , _____
2. Frame Size :	<input type="checkbox"/> Pass	<input type="checkbox"/> NG , _____
3. Material of Frame :	<input type="checkbox"/> Pass	<input type="checkbox"/> NG , _____
4. Connector Position :	<input type="checkbox"/> Pass	<input type="checkbox"/> NG , _____
5. Fix Hole Position :	<input type="checkbox"/> Pass	<input type="checkbox"/> NG , _____
6. Backlight Position :	<input type="checkbox"/> Pass	<input type="checkbox"/> NG , _____
7. Thickness of PCB :	<input type="checkbox"/> Pass	<input type="checkbox"/> NG , _____
8. Height of Frame to PCB :	<input type="checkbox"/> Pass	<input type="checkbox"/> NG , _____
9. Height of Module :	<input type="checkbox"/> Pass	<input type="checkbox"/> NG , _____
10. Others :	<input type="checkbox"/> Pass	<input type="checkbox"/> NG , _____

**3 、 Relative Hole Size :**

1. Pitch of Connector :	<input type="checkbox"/> Pass	<input type="checkbox"/> NG , _____
2. Hole size of Connector :	<input type="checkbox"/> Pass	<input type="checkbox"/> NG , _____
3. Mounting Hole size :	<input type="checkbox"/> Pass	<input type="checkbox"/> NG , _____
4. Mounting Hole Type :	<input type="checkbox"/> Pass	<input type="checkbox"/> NG , _____
5. Others :	<input type="checkbox"/> Pass	<input type="checkbox"/> NG , _____

**4 、 Backlight Specification :**

1. B/L Type :	<input type="checkbox"/> Pass	<input type="checkbox"/> NG , _____
2. B/L Color :	<input type="checkbox"/> Pass	<input type="checkbox"/> NG , _____
3. B/L Driving Voltage (Reference for LED Type) :	<input type="checkbox"/> Pass	<input type="checkbox"/> NG , _____
4. B/L Driving Current :	<input type="checkbox"/> Pass	<input type="checkbox"/> NG , _____
5. Brightness of B/L :	<input type="checkbox"/> Pass	<input type="checkbox"/> NG , _____
6. B/L Solder Method :	<input type="checkbox"/> Pass	<input type="checkbox"/> NG , _____
7. Others :	<input type="checkbox"/> Pass	<input type="checkbox"/> NG , _____

>> **Go to page 2** <<

<b>Module Number :</b> _____		
<b>5 · <u>Electronic Characteristics of Module</u> :</b>		
1.Input Voltage :	<input type="checkbox"/> Pass	<input type="checkbox"/> NG , _____
2.Supply Current :	<input type="checkbox"/> Pass	<input type="checkbox"/> NG , _____
3.Driving Voltage for LCD :	<input type="checkbox"/> Pass	<input type="checkbox"/> NG , _____
4.Contrast for LCD :	<input type="checkbox"/> Pass	<input type="checkbox"/> NG , _____
5.B/L Driving Method :	<input type="checkbox"/> Pass	<input type="checkbox"/> NG , _____
6.Negative Voltage Output :	<input type="checkbox"/> Pass	<input type="checkbox"/> NG , _____
7.Interface Function :	<input type="checkbox"/> Pass	<input type="checkbox"/> NG , _____
8.LCD Uniformity :	<input type="checkbox"/> Pass	<input type="checkbox"/> NG , _____
9.ESD test :	<input type="checkbox"/> Pass	<input type="checkbox"/> NG , _____
10.Others :	<input type="checkbox"/> Pass	<input type="checkbox"/> NG , _____
<b>6 · <u>Summary</u> :</b>		
<p style="text-align: right; margin-right: 50px;">Sales signature : _____</p> <p style="text-align: right; margin-right: 100px;">Customer Signature : _____</p> <p style="text-align: right; margin-right: 100px;">Date :    /    /    _____</p>		