



RAYSTAR

曜凌光電股份有限公司

住址: 42878 台中市大雅区科雅路 25 號 5F WEB: <http://www.Raystar-Optronics.com>
5F., No.25, Keya Rd., Daya Dist., Taichung E-mail: sales@raystar-optronics.com
City 428, Taiwan Tel:886-4-2565-0761 Fax : 886-4-2565-0760

RFF1020Q-1IW-DBN

SPECIFICATION

CUSTOMER:

APPROVED BY	
PCB VERSION	
DATE	

FOR CUSTOMER USE ONLY

SALES BY	APPROVED BY	CHECKED BY	PREPARED BY

Release DATE:

Revision History

VERSION	DATE	REVISED PAGE NO.	Note
0	2014/02/25		First issue
A	2014/11/10		Add size & Surface. Modify Pixel Data Format & Block Diagram & Static electricity test.
B	2015/06/23		Modify Reliability

Contents

1. Module Classification Information
2. Summary
3. General Specification
4. Interface
5. Contour Drawing
6. Block Diagram
7. Absolute Maximum Ratings
8. Electrical Characteristics
9. DC Characteristics
10. Interface Timing Characteristics
11. Optical Characteristics
12. Reliability
13. Package Specification
14. Initial Code For Reference
15. Other

1.Module Classification Information

R	F	F	102	0Q	-	1	I	W	-	D	B	N
1	2	3	4	5	-	6	7	8	-	9	10	11

Item	Description	
1	R : Raystar Optronics Inc.	
2	Display Type : F→TFT Type, J→ Custom TFT	
3	Solution: A: 128x160 B:320x234 C:320x240 D:480x234 E:480x272 F:800x480 G:640x480 H:1024x600 I:320x480 J:320x400 K:1280x800 L:240x400 M:1024x768 N:128x128 O:480x800 P:640x320 Q:800x600 S:480x128 T:800x320	
4	Display Size : 10.2" TFT	
5	Version Code.	
6	Model Type: A : TFT LCD E : TFT+FR+CONTROL BOARD J : TFT+FR+A/D BOARD N : TFT+FR+A/D BOARD+CONTROL BOARD S : TFT+FR+POWER BOARD (DC TO DC) 1 : TFT+CONTROL BOARD	6 : TFT+FR H : TFT+D/V BOARD I : TFT+FR+D/V BOARD B : TFT+POWER BD
7	Polarizer Type, Temperature range, View direction	I→Transmissive, W. T, 6:00 ; C→Transmissive, N. T, 6:00 L→Transmissive, W.T,12:00 ; F→Transmissive, N.T,12:00 Y→Transmissive,W.T, IPS TFT ; A→Transmissive, N.T, IPS TFT Z→Transmissive, W.T, O-TFT R→Transmissive, Super W.T, O-TFT N→Transmissive, Super W.T, 6:00; Q→Transmissive, Super W.T, 12:00 V→Transmissive, Super W.T, VA TFT
8	Backlight	W : LED, White H : LED, High Light White F : CCFL, White
9	Driver Method	D: Digital A: Analog L : LVDS M:MIPI
10	Interface	N : without control board A : 8Bit B : 16Bit S:SPI Interface R: RS232 U:USB I: I2C
11	TS	N : Without TS S : resistive touch panel C : capacitive touch panel capacitive touch panel (G-F-F) G : capacitive touch panel(G-G)

2.Summary

This technical specification applies to 10.2' color TFT-LCD panel. The 10.2' color TFT-LCD panel is designed for camcorder, digital camera application and other electronic products which require high quality flat panel displays. This module follows RoHS.

3. General Specifications

- Size: 10.2 inch
- Dot Matrix: 800 RGB x 480 dots
- Module dimension: 235.0 (H) x145.0 (V) x 10.2 (D) mm
- Active area: 222.0(W) × 132.48(H) mm
- Dot pitch: 0.0925(W) × 0.276(H) mm
- LCD type: TFT, Normally White, Transmissive
- View Direction: 12 o'clock
- Gray Scale Inversion Direction: 6 o'clock
- Backlight Type: LED, Normally White
- Controller IC: SSD1963
- Interface: Digital 8080 family MPU 8bit/16bit
- With /Without TP: Without TP
- Surface: Anti-Glare

*Color tone slight changed by temperature and driving voltage.

4.Interface

4.1. LCM PIN Definition (CON2)

Pin	Symbol	Function	Remark
1	GND	System ground pin of the IC . Connect to system ground.	
2	VDD	Power Supply : +3.3V	
3	BLE	Backlight control signal , H: On \ L: Off	
4	D/C	Data/Command select	
5	WR	Write strobe signal	
6	RD	Read strobe signal	
7	DB0	Data bus	
8	DB1	Data bus	
9	DB2	Data bus	
10	DB3	Data bus	
11	DB4	Data bus	
12	DB5	Data bus	
13	DB6	Data bus	
14	DB7	Data bus	
15	DB8	Data bus (When select 8bits Mode, this pin is NC)	Note1
16	DB9	Data bus (When select 8bits Mode, this pin is NC)	Note1
17	DB10	Data bus (When select 8bits Mode, this pin is NC)	Note1
18	DB11	Data bus (When select 8bits Mode, this pin is NC)	Note1
19	DB12	Data bus (When select 8bits Mode, this pin is NC)	Note1
20	DB13	Data bus (When select 8bits Mode, this pin is NC)	Note1
21	DB14	Data bus (When select 8bits Mode, this pin is NC)	Note1
22	DB15	Data bus (When select 8bits Mode, this pin is NC)	Note1
23	NC	No connect	
24	NC	No connect	
25	CS	Chip select	
26	RST	Hardware reset	
27	L/R	Left / right selection; Default L/R=H	Note 2,3
28	U/D	Up/down selection; ; Default U/D=L	Note 2,3
29	NC	No connect	
30	NC	No connect	
31	NC	No connect	
32	NC	No connect	
33	VLED-	Power for LED Driver IC(GND)	
34	VLED-	Power for LED Driver IC(GND)	
35	VLED+	Power for LED Driver IC(+5V)	
36	VLED+	Power for LED Driver IC(+5V)	

Note1: When select 8bit mode, DB0~DB7 be used, DB8~DB15 no connect
When select 16bit mode, DB0~DB15 be used

Note 2: Selection of scanning mode

Setting of scan control input		Scanning direction
U/D	L/R	
GND	VDD	Up to down, left to right
VDD	GND	Down to up, right to left
GND	GND	Up to down, right to left
VDD	VDD	Down to up, left to right

Note 3: Definition of scanning direction. Refer to the figure as below:



U/D=L, L/R=H

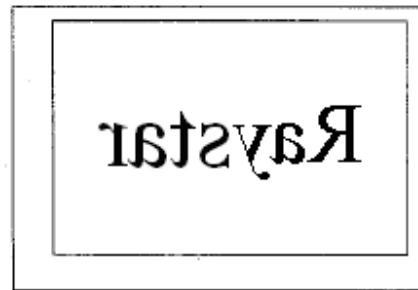

U/D=L, L/R=L

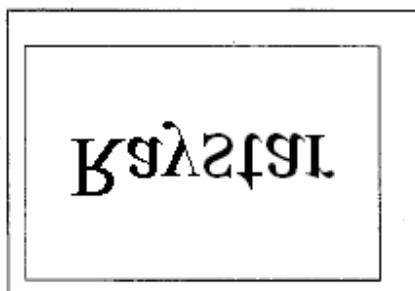

U/D=H, L/R=H

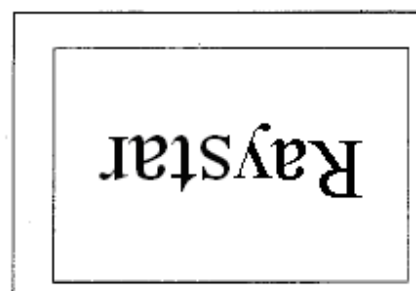

U/D=H, L/R=L

5. Contour Drawing

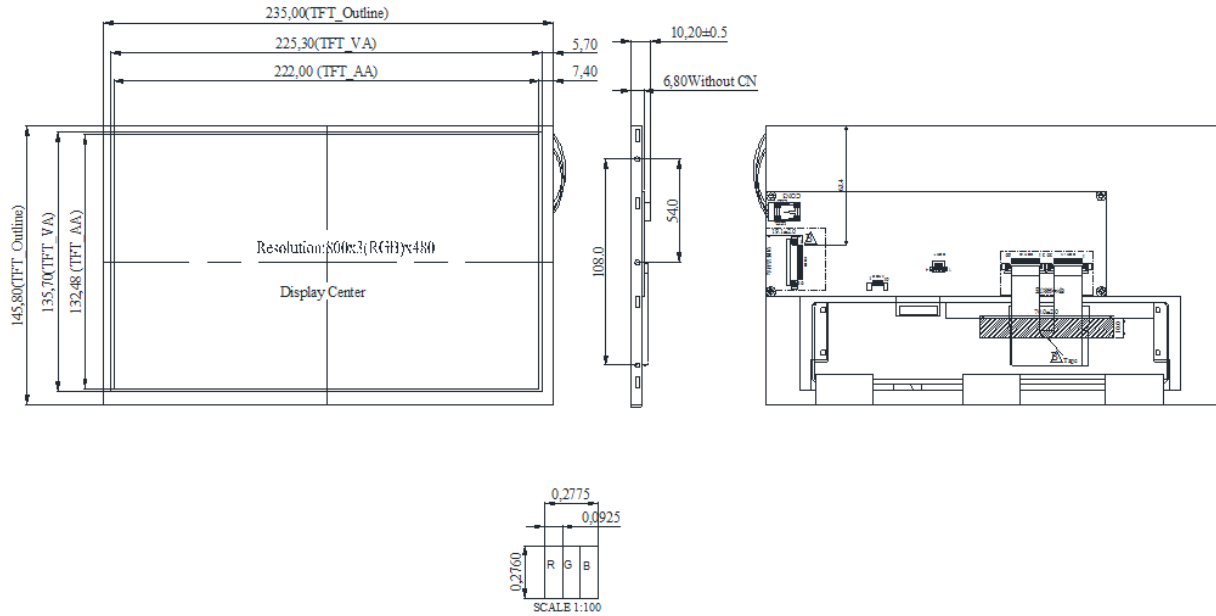

Pin No	SYMBOL
1	GND
2	VDD
3	BL - F
4	D/C
5	WR
6	RD
7	DB0
8	DB1
9	DB2
10	DB3
11	DB4
12	DB5
13	DB6
14	DB7
15	DB8
16	DB9
17	DB10
18	DB11
19	DB12
20	DB13
21	DB14
22	DB15
23	NC
24	NC
25	CS
26	RESET
27	LR
28	UD
29	NC
30	NC
31	NC
32	NC
33	VLED-
34	VLED-
35	VLED+
36	VLED+

The non-specified tolerance of dimension is ±0.3mm.

6. Block Diagram

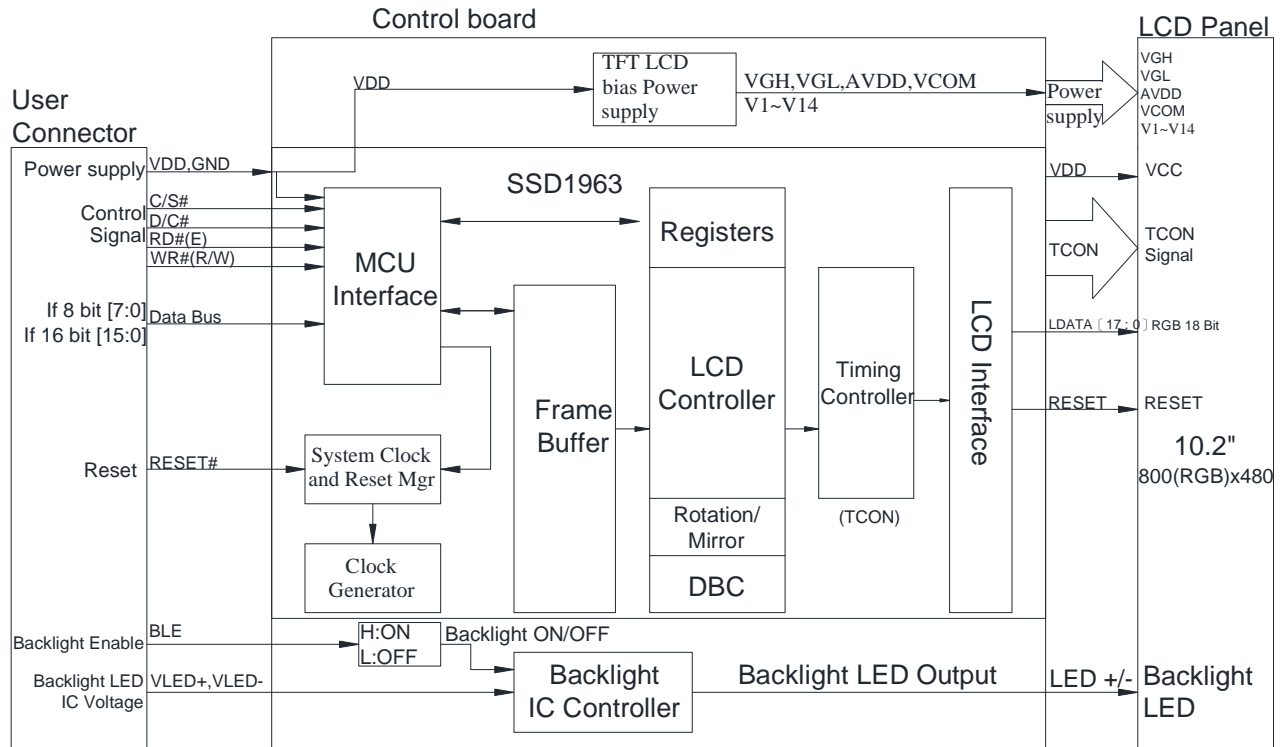

7. Absolute Maximum Ratings

Item	Symbol	Min	Typ	Max	Unit
Operating Temperature	TOP	-20	—	+70	°C
Storage Temperature	TST	-30	—	+80	°C

Note: Device is subject to be damaged permanently if stresses beyond those absolute maximum ratings listed above

- Temp. $\leq 60^{\circ}\text{C}$, 90% RH MAX. Temp. $> 60^{\circ}\text{C}$, Absolute humidity shall be less than 90% RH at 60°C

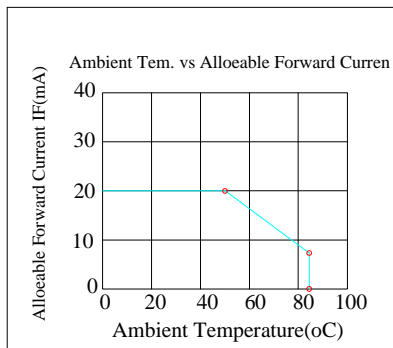

8. Electrical Characteristics

8.1. Operating conditions: (CON2.Pin1=GND, Pin2=VDD)

Item	Symbol	Condition	Min	Typ	Max	Unit	Remark
Supply Voltage For LCM	VDD	—	3.0	3.1	3.3	V	—
Supply Current For LCM	IDD	—	—	160	225	mA	Note1

Note 1 : This value is test for VDD=3.3V , Ta=25°C only

8.2. Backlight driving conditions (CON2.Pin33,34=VLED-, Pin35,36=VLED+)

Parameter	Symbol	Min.	Typ.	Max.	Unit	Remark
Operation Current For LED Driver	VLED=5V	500	—	750	mA	Note 1,2
Power Consumption	VLED=5V	2500	—	3750	mW	Note 1,2
Supply Voltage For LED Driver	VLED+	—	5	—	V	—
LED Life Time	—	20,000	—	—	Hr	Note 2,3,4

Note 1 : Base on VLED= 5V for the back light driver IC specification

Note 2 : Ta = 25 °C

Note 3 : Brightness to be decreased to 50% of the initial value

Note 4 : The single LED lamp case

9.DC CHARATERISTICS

Parameter	Symbol	Rating			Unit	Condition
		Min	Typ	Max		
Low level input voltage	V_{IL}	0	-	0.3VDD	V	
High level input voltage	V_{IH}	0.7VDD	-	VDD	V	

10. Interface timing

10.1. 8080 Mode

The 8080 mode MCU interface consist of CS#, D/C#, RD#, WR#, DATA BUS. This interface use WR# to define a write cycle and RD# for read cycle. If the WR# goes low when the CS# signal is low, the data or command will be latched into the system at the rising edge of WR#. Similarly, the read cycle will start when RD# goes low and end at the rising edge of RD#.

10.2. 8080 Mode Write Cycle

Symbol	Parameter	Min	Typ	Max	Unit
fMCLK	System Clock Frequency	1	-	110	MHz
tMCLK	System Clock Period	1/ fMCLK	-	-	ns
tPWCSH	Control Pulse High Width Write Read	13 30	1.5* tMCLK 3.5* tMCLK	-	ns
tPWCSL	Control Pulse Low Width Write (next write cycle) Write (next read cycle) Read	13 80 80	1.5* tMCLK 9* tMCLK 9* tMCLK	-	ns
tAS	Address Setup Time	1	-	-	ns
tAH	Address Hold Time	2	-	-	ns
tDSW	Write Data Setup Time	4	-	-	ns
tDHW	Write Data Hold Time	1	-	-	ns
tPWLW	Write Low Time	12	-	-	ns
tDHR	Read Data Hold Time	1	-	-	ns
tACC	Access Time	32	-	-	ns
tPWLR	Read Low Time	36	-	-	ns
tR	Rise Time	-	-	0.5	ns
tF	Fall Time	-	-	0.5	ns
tCS	Chip select setup time	2	-	-	ns
tCSH	Chip select hold time to read signal	3	-	-	ns

10.3. Parallel 8080-series Interface Timing Diagram(Write Cycle)

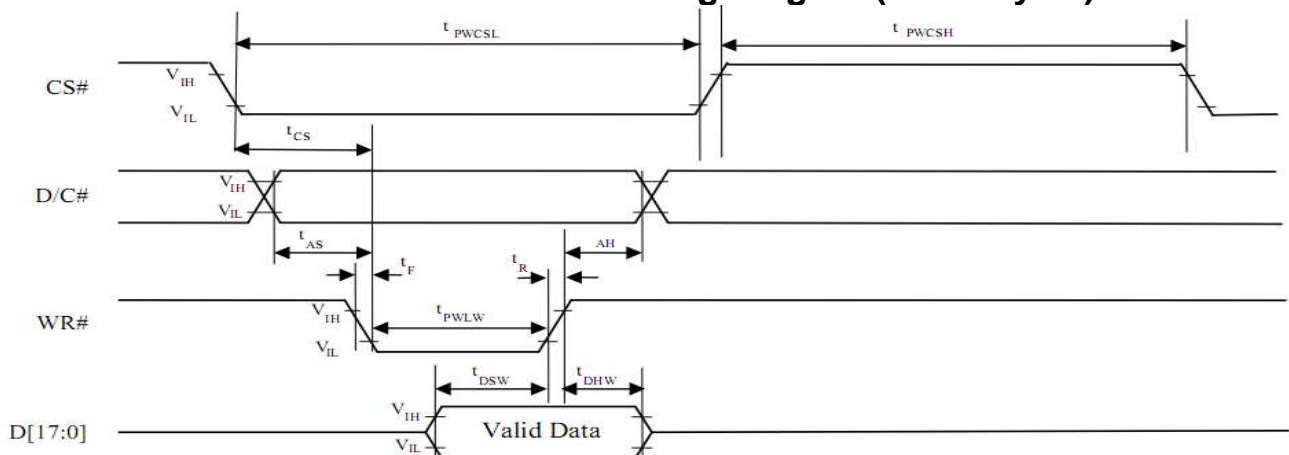

10.4. Parallel 8080-series Interface Timing Diagram(Read Cycle)

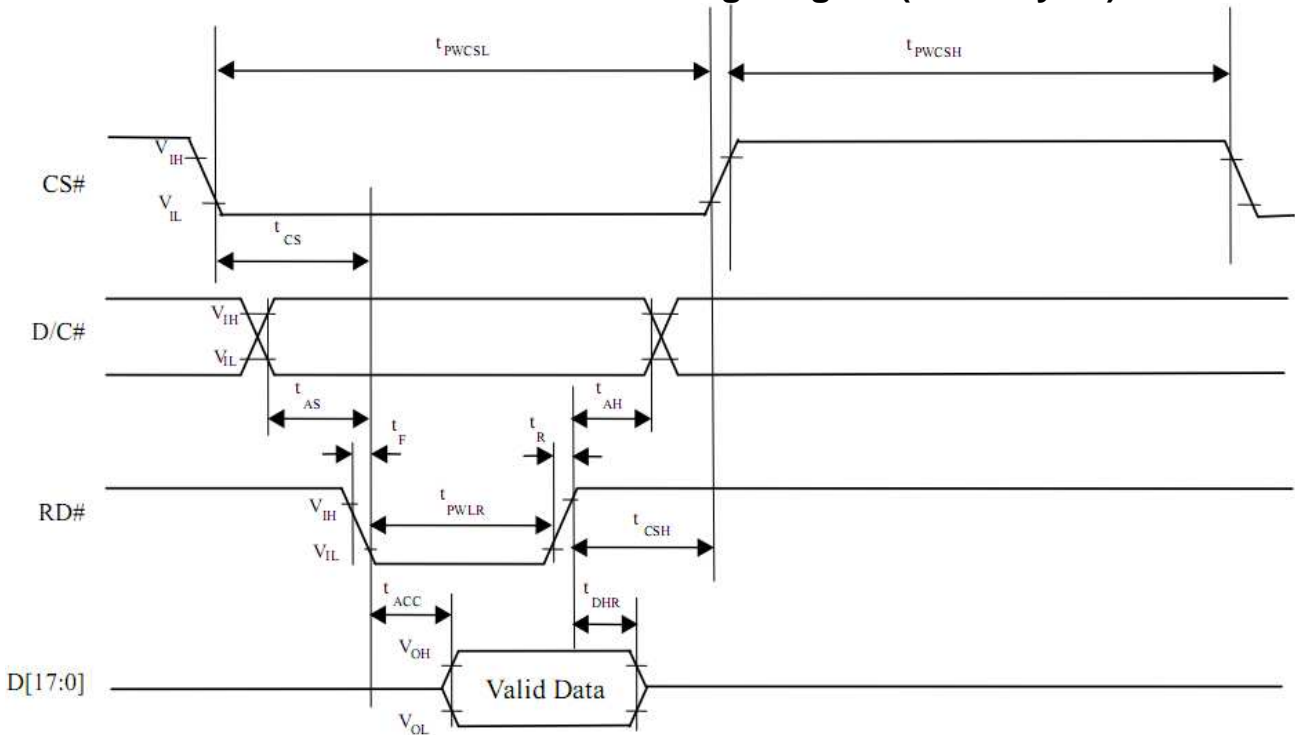

10.5. Pixel Data Format

Interface	Cycle	D[15]	D[14]	D[13]	D[12]	D[11]	D[10]	D[9]	D[8]	D[7]	D[6]	D[5]	D[4]	D[3]	D[2]	D[1]	D[0]
16 bits (565 format)	1 st	R5	R4	R3	R2	R1	G5	G4	G3	G2	G1	G0	B5	B4	B3	B2	B1
16 bits	1 st	R7	R6	R5	R4	R3	R2	R1	R0	G7	G6	G5	G4	G3	G2	G1	G0
	2 nd	B7	B6	B5	B4	B3	B2	B1	B0	R7	R6	R5	R4	R3	R2	R1	R0
	3 rd	G7	G6	G5	G4	G3	G2	G1	G0	B7	B6	B5	B4	B3	B2	B1	B0
8 bits	1 st									R7	R6	R5	R4	R3	R2	R1	R0
	2 nd									G7	G6	G5	G4	G3	G2	G1	G0
	3 rd									B7	B6	B5	B4	B3	B2	B1	B0

11. Optical Characteristics

TFT LCD characteristic

Item	Symbol	Condition.	Min	Typ.	Max.	Unit	Remark	
Response time	T_r	$\theta=0^\circ, \Phi=0^\circ$	-	15	30	ms	Note 3,5	
	T_f		-	20	40	ms		
Contrast ratio	CR	At optimized viewing angle	250	300	-	-	Note 4,5	
Color Chromaticity	White	W_x	$\theta=0^\circ, \Phi=0^\circ$	0.26	0.31	0.36	-	Note 2,6,7
		W_y		0.28	0.33	0.38	-	-
Viewing angle (Gray Scale Inversion Direction)	Hor.	θ_R	$CR \geq 10$	55	65	-	Deg.	Note 1
		θ_L		55	65	-		
	Ver.	ϕ_T		35	45	-		
		ϕ_B		55	65	-		
Brightness	-	-	280	350	-	cd/m^2	Center of display	

$T_a=25\pm 2^\circ C$, VLED / ILED= 5V / 500mA

Note 1: Definition of viewing angle range

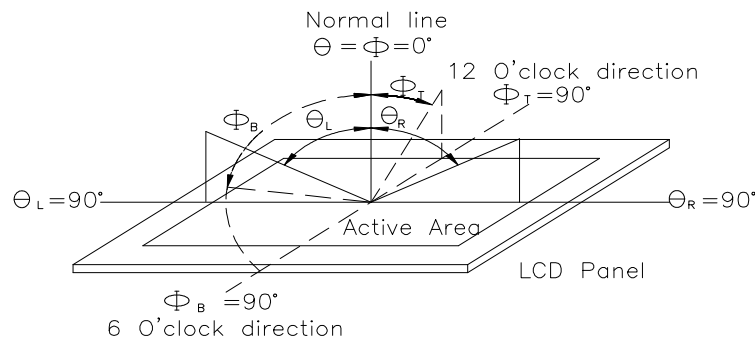

Fig.11.1. Definition of viewing angle

Note 2: Test equipment setup:

After stabilizing and leaving the panel alone at a driven temperature for 10 minutes, the measurement should be executed. Measurement should be executed in a stable, windless, and dark room. Optical specifications are measured by Topcon BM-7orBM-5 luminance meter 1.0° field of view at a distance of 50cm and normal direction.

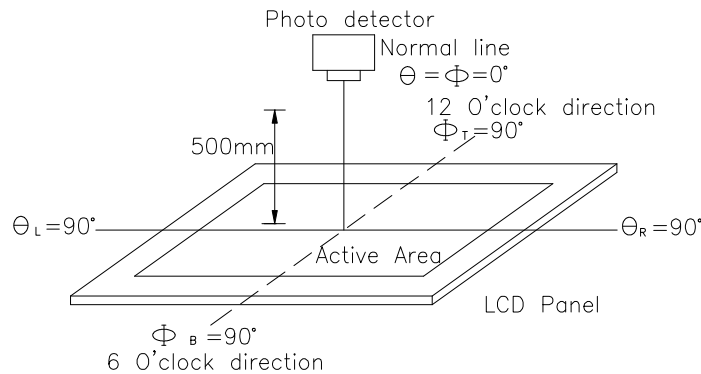
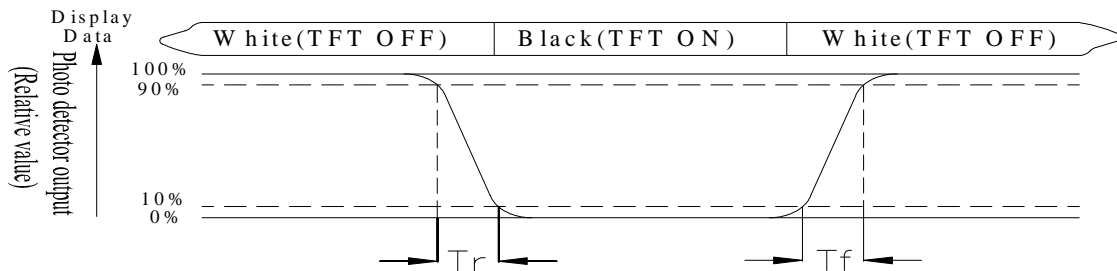

Fig. 11.2. Optical measurement system setup

Note 3: Definition of Response time:

The response time is defined as the LCD optical switching time interval between “White” state and “Black” state. Rise time, T_r , is the time between photo detector output intensity changed from 90% to 10%. And fall time, T_f , is the time between photo detector output intensity changed from 10% to 90%



Note 4: Definition of contrast ratio:

The contrast ratio is defined as the following expression.

$$\text{Contrast ratio (CR)} = \frac{\text{Luminance measured when LCD on the "White" state}}{\text{Luminance measured when LCD on the "Black" state}}$$

Note 5: White $V_i = V_{i50} \pm 1.5V$

Black $V_i = V_{i50} \pm 2.0V$

“±” means that the analog input signal swings in phase with VCOM signal.

“±” means that the analog input signal swings out of phase with VCOM signal.

The 100% transmission is defined as the transmission of LCD panel when all the input terminals of module are electrically opened.

Note 6: Definition of color chromaticity (CIE 1931)

Color coordinates measured at the center point of LCD

Note 7: Measured at the center area of the panel when all the input terminals of LCD panel are electrically opened.

12. Reliability

Content of Reliability Test (Wide temperature, -20°C ~70°C)

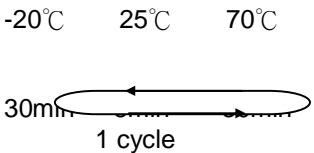
Environmental Test			
Test Item	Content of Test	Test Condition	Note
High Temperature storage	Endurance test applying the high storage temperature for a long time.	80°C 200hrs	2
Low Temperature storage	Endurance test applying the low storage temperature for a long time.	-30°C 200hrs	1,2
High Temperature Operation	Endurance test applying the electric stress (Voltage & Current) and the thermal stress to the element for a long time.	70°C 200hrs	—
Low Temperature Operation	Endurance test applying the electric stress under low temperature for a long time.	-20°C 200hrs	1
High Temperature/ Humidity Operation	The module should be allowed to stand at 60°C,90%RH max	60°C,90%RH 96hrs	1,2
Thermal shock resistance	The sample should be allowed stand the following 10 cycles of operation <div style="text-align: center;">  <p>-20°C 25°C 70°C</p> <p>30min</p> <p>1 cycle</p> </div>	-20°C/70°C 10 cycles	—
Vibration test	Endurance test applying the vibration during transportation and using.	Total fixed amplitude : 3 15mm Vibration Frequency : 10~55Hz One cycle 60 seconds to 3 directions of X,Y,Z for Each 15 minutes	3
Static electricity test	Endurance test applying the electric stress to the terminal.	VS=800V, RS=1.5kΩ CS=100pF 1 time	—

Note1: No dew condensation to be observed.

Note2: The function test shall be conducted after 4 hours storage at the normal Temperature and humidity after remove from the test chamber.

Note3: The packing have to including into the vibration testing.

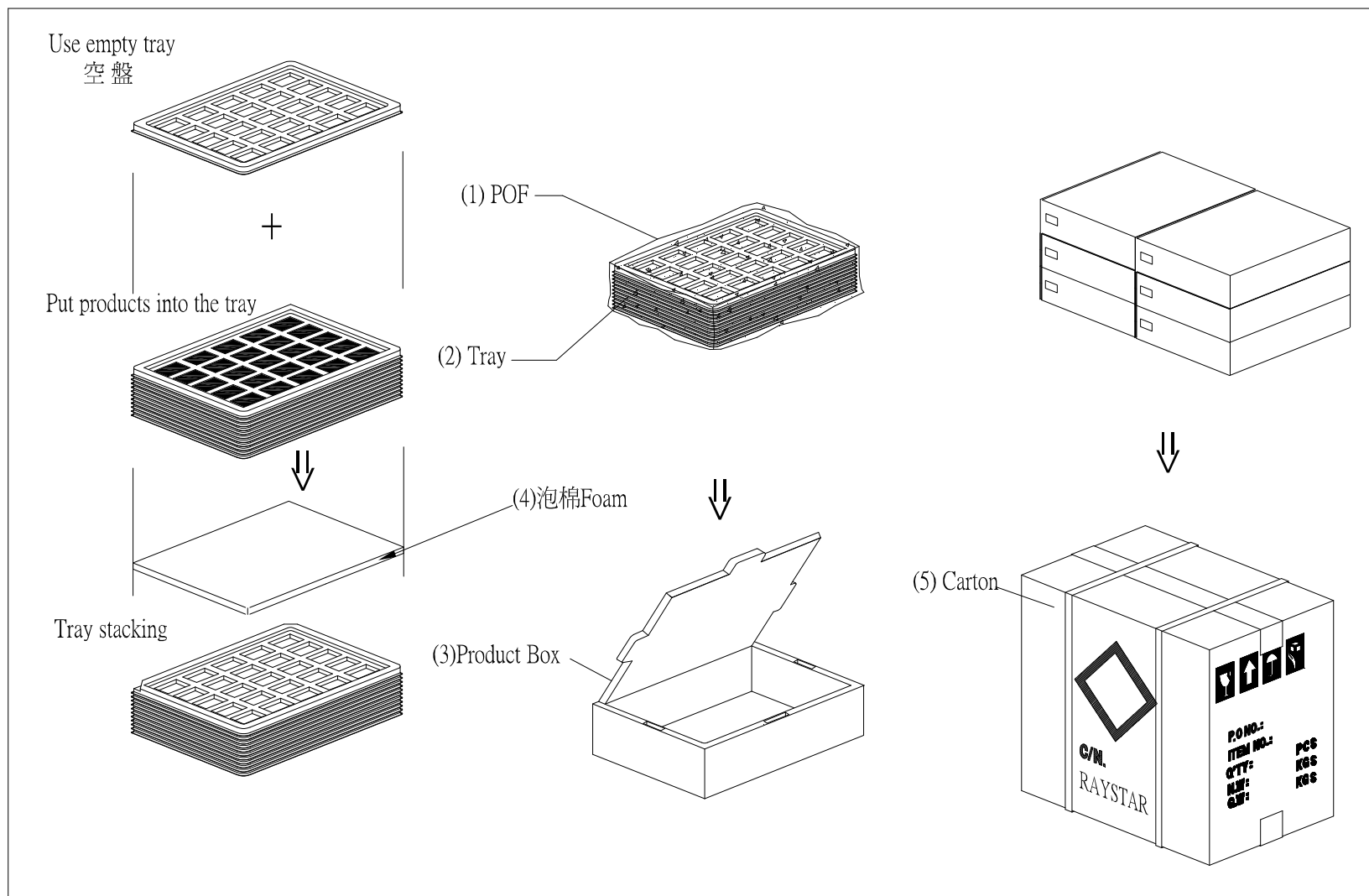

14.Initial Code For Reference

```
void Initial_SSD1963()
{
    Write_Command(0x01);
    Write_Command(0x01);
    Write_Command(0x01);

    Command_Write(0xe0,0x01);
    Command_Write(0xe0,0x03);
    Write_Command(0xb0);
    Write_Data(0x08);
    Write_Data(0x80);
    Write_Data(0x03);
    Write_Data(0x1f);
    Write_Data(0x01);
    Write_Data(0xdf);
    Write_Data(0x2d);

    Command_Write(0xf0,0x03);
    Command_Write(0x3a,0x50);

    Command_Write(0x36,0x08);

    Write_Command(0xe2);
    Write_Data(0x22);
    Write_Data(0x03);
    Write_Data(0x04);

    Write_Command(0xe6);
    Write_Data(0x03);
    Write_Data(0xff);
    Write_Data(0xff);

    Write_Command(0xb4);
    Write_Data(0x04);
    Write_Data(0x25);
    Write_Data(0x00);
    Write_Data(0x34);
    Write_Data(0x05);
    Write_Data(0x00);
    Write_Data(0x00);
    Write_Data(0x00);
    Write_Data(0x00);

    Write_Command(0xb6);
    Write_Data(0x02);
```

Write_Data(0x12);
Write_Data(0x00);
Write_Data(0x1d);
Write_Data(0x05);
Write_Data(0x00);
Write_Data(0x00);

Write_Command(0x2a);
Write_Data(0x00);
Write_Data(0x00);
Write_Data(0x03);
Write_Data(0x1f);

Write_Command(0x2b);
Write_Data(0x00);
Write_Data(0x00);
Write_Data(0x01);
Write_Data(0xdf);

Write_Command(0xb8);
Write_Data(0x0f);
Write_Data(0x01);
Write_Command(0xba);
Write_Data(0x01);

Write_Command(0x29);
Write_Command(0x2c);

}

LCM Sample Estimate Feedback Sheet

Module Number : _____

1 、 Panel Specification :

1. Panel Type :	<input type="checkbox"/> Pass	<input type="checkbox"/> NG , _____
2. View Direction :	<input type="checkbox"/> Pass	<input type="checkbox"/> NG , _____
3. Numbers of Dots :	<input type="checkbox"/> Pass	<input type="checkbox"/> NG , _____
4. View Area :	<input type="checkbox"/> Pass	<input type="checkbox"/> NG , _____
5. Active Area :	<input type="checkbox"/> Pass	<input type="checkbox"/> NG , _____
6. Operating Temperature :	<input type="checkbox"/> Pass	<input type="checkbox"/> NG , _____
7. Storage Temperature :	<input type="checkbox"/> Pass	<input type="checkbox"/> NG , _____
8. Others : _____		

2 、 Mechanical Specification :

1. PCB Size :	<input type="checkbox"/> Pass	<input type="checkbox"/> NG , _____
2. Frame Size :	<input type="checkbox"/> Pass	<input type="checkbox"/> NG , _____
3. Material of Frame :	<input type="checkbox"/> Pass	<input type="checkbox"/> NG , _____
4. Connector Position :	<input type="checkbox"/> Pass	<input type="checkbox"/> NG , _____
5. Fix Hole Position :	<input type="checkbox"/> Pass	<input type="checkbox"/> NG , _____
6. Backlight Position :	<input type="checkbox"/> Pass	<input type="checkbox"/> NG , _____
7. Thickness of PCB :	<input type="checkbox"/> Pass	<input type="checkbox"/> NG , _____
8. Height of Frame to PCB :	<input type="checkbox"/> Pass	<input type="checkbox"/> NG , _____
9. Height of Module :	<input type="checkbox"/> Pass	<input type="checkbox"/> NG , _____
10. Others :	<input type="checkbox"/> Pass	<input type="checkbox"/> NG , _____

3 、 Relative Hole Size :

1. Pitch of Connector :	<input type="checkbox"/> Pass	<input type="checkbox"/> NG , _____
2. Hole size of Connector :	<input type="checkbox"/> Pass	<input type="checkbox"/> NG , _____
3. Mounting Hole size :	<input type="checkbox"/> Pass	<input type="checkbox"/> NG , _____
4. Mounting Hole Type :	<input type="checkbox"/> Pass	<input type="checkbox"/> NG , _____
5. Others :	<input type="checkbox"/> Pass	<input type="checkbox"/> NG , _____

4 、 Backlight Specification :

1. B/L Type :	<input type="checkbox"/> Pass	<input type="checkbox"/> NG , _____
2. B/L Color :	<input type="checkbox"/> Pass	<input type="checkbox"/> NG , _____
3. B/L Driving Voltage (Reference for LED Type) : <input type="checkbox"/> Pass <input type="checkbox"/> NG , _____		
4. B/L Driving Current :	<input type="checkbox"/> Pass	<input type="checkbox"/> NG , _____
5. Brightness of B/L :	<input type="checkbox"/> Pass	<input type="checkbox"/> NG , _____
6. B/L Solder Method :	<input type="checkbox"/> Pass	<input type="checkbox"/> NG , _____
7. Others :	<input type="checkbox"/> Pass	<input type="checkbox"/> NG , _____

>> **Go to page 2** <<

Module Number : _____		
5 · <u>Electronic Characteristics of Module</u> :		
1.Input Voltage :	<input type="checkbox"/> Pass	<input type="checkbox"/> NG , _____
2.Supply Current :	<input type="checkbox"/> Pass	<input type="checkbox"/> NG , _____
3.Driving Voltage for LCD :	<input type="checkbox"/> Pass	<input type="checkbox"/> NG , _____
4.Contrast for LCD :	<input type="checkbox"/> Pass	<input type="checkbox"/> NG , _____
5.B/L Driving Method :	<input type="checkbox"/> Pass	<input type="checkbox"/> NG , _____
6.Negative Voltage Output :	<input type="checkbox"/> Pass	<input type="checkbox"/> NG , _____
7.Interface Function :	<input type="checkbox"/> Pass	<input type="checkbox"/> NG , _____
8.LCD Uniformity :	<input type="checkbox"/> Pass	<input type="checkbox"/> NG , _____
9.ESD test :	<input type="checkbox"/> Pass	<input type="checkbox"/> NG , _____
10.Others :	<input type="checkbox"/> Pass	<input type="checkbox"/> NG , _____
6 · <u>Summary</u> :		
<p style="margin-left: 100px;">Sales signature : _____</p> <p style="margin-left: 100px;">Customer Signature : _____ Date : / / _____</p>		