



**MULTI-INNO TECHNOLOGY CO., LTD.**

[www.multi-inno.com](http://www.multi-inno.com)

## LCD MODULE SPECIFICATION

**Model : MI0283QT-17CP3**

This module uses ROHS material

### For Customer's Acceptance:

Customer	
Approved	
Comment	

The standard product specification may change without prior notice in order to improve performance or quality. Please contact Multi-Inno for updated specification and product status before design for the standard product or release of the order.

Revision	1.0
Engineering	
Date	2019-05-22
Our Reference	





# CONTENTS

- GENERAL INFORMATION
- EXTERNAL DIMENSIONS
- ABSOLUTE MAXIMUM RATINGS
- ELECTRICAL CHARACTERISTICS
- BACKLIGHT CHARACTERISTICS
- ELECTRO-OPTICAL CHARACTERISTICS
- INTERFACE DESCRIPTION
- APPLICATION NOTES
- CTP SPECIFICATIONS
- RELIABILITY TEST
- INSPECTION CRITERION
- PRECAUTIONS FOR USING LCD MODULES
- PACKING SPECIFICATION
- PRIOR CONSULT MATTER

**■ GENERAL INFORMATION**

Item	Contents	Unit/Note
LCD Type	TFT / Transmissive / Normally White	/
Size	2.83	Inch
Viewing Direction	6:00 (without image inversion and least brightness change)	O'Clock
Gray Scale Inversion Direction	12:00 (contrast peak located at)	O'Clock
LCM (W × H × D)	50.20 × 69.30 × 4.60	mm <sup>3</sup>
Active Area (W × H)	43.20 × 57.60	mm <sup>2</sup>
Pixel Pitch	0.18 × 0.18	mm <sup>2</sup>
Number of Dots	240 (RGB) x 320	/
Driver IC	ILI9341V	/
Backlight Type	4LEDs	/
Interface Type	(1) 8- / 9- / 16- / 18-bit Parallel CPU	/
	(2) 6- / 16- / 18-bit Parallel RGB	/
	(3) 3- / 4-wire SPI	/
Color Depth	65K / 262K	/
Pixel Configuration	R.G.B Vertical Stripe	/
Top Polarizer Surface Treatment	Glare	/
Input Voltage	2.8	V
With / Without TSP	With CTP	/
TP Surface Treatment	Glare	/
Weight	TBD	g

Note 1: RoHS compliant;

Note 2: LCM weight tolerance: ±5%.

EXTERNAL DIMENSIONS

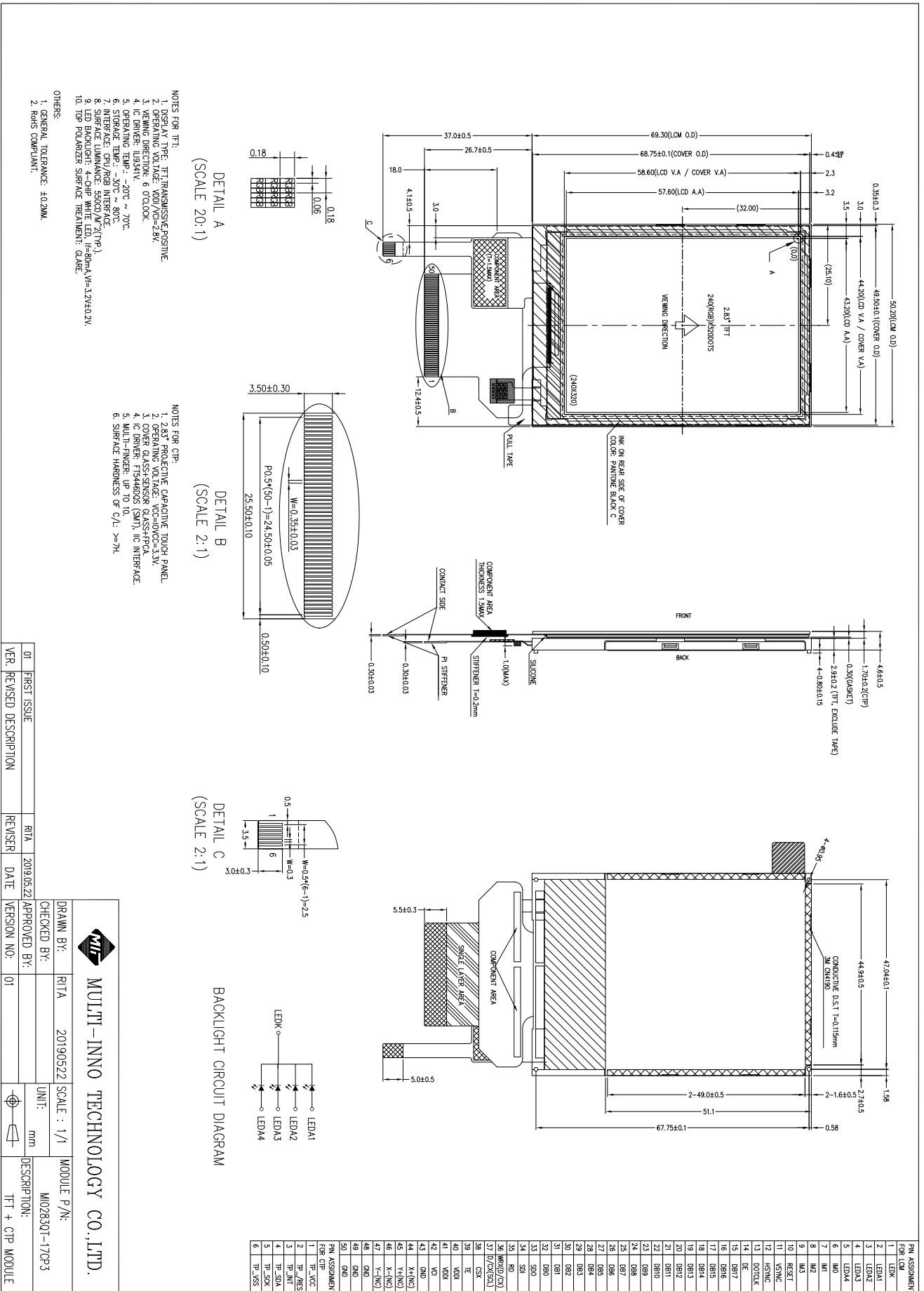

**■ ABSOLUTE MAXIMUM RATINGS**

Parameter	Symbol	Min.	Max.	Unit
Supply Voltage for Logic	VCI	-0.3	4.6	V
Supply Voltage for Analog	VDDI	-0.3	4.6	V
Operating Temperature	TOP	-20	70	°C
Storage Temperature	TST	-30	80	°C

**■ ELECTRICAL CHARACTERISTICS**

Parameter	Symbol	Min.	Typ.	Max.	Unit	Remark
Supply Voltage for Logic	VCI	2.5	2.8	3.3	V	
Supply Voltage for Analog	VDDI	1.65	2.8	3.3	V	
Input Voltage 'H' Level	VIH	0.7VDDI	-	VDDI	V	
Input Voltage 'L' Level	VIL	GND	-	0.3VDDI	V	
Output Voltage 'H' Level	VOH	0.8VDDI	-	VDDI	V	
Output Voltage 'L' Level	VOL	GND	-	0.2VDDI	V	

**■ BACKLIGHT CHARACTERISTICS**

Parameter	Symbol	Min	Typ	Max	Unit	Condition
Forward Voltage	Vf	2.7	3.2	3.4	V	Ta=25±2°C 60%RH±5 %
Forward Current	If	-	80	-	mA	
Power Consumption	WBL	-	256	-	mW	
Operating Life Time	-	30000	40000	-	Hrs	

Note: Operating life time means brightness goes down to 50% initial brightness;

The life time of LED will be reduced if LED is driven by high current, high ambient temperature and humidity conditions.

Typical operating life time is an estimated data.

## ■ ELECTRO-OPTICAL CHARACTERISTICS

Item	Symbol	Condition	Min	Typ	Max	Unit	Remark	Note
Response Time	Tr+Tf	$\theta = 0^\circ$ $\phi = 0^\circ$ $T_a = 25^\circ\text{C}$	-	25	30	ms	Fig.1	4
Contrast Ratio	Cr		400	500	-	---	Fig.2	1
Luminance Uniformity	$\delta$ White		80	90	-	%	Fig.2	3
Surface Luminance	Lv		400	550	-	cd/m <sup>2</sup>	Fig.2	2
Viewing Angle Range	$\theta$	$\phi = 90^\circ$	55	70	-	deg	Fig.3	6
		$\phi = 270^\circ$	42	57	-	deg	Fig.3	
		$\phi = 0^\circ$	55	70	-	deg	Fig.3	
		$\phi = 180^\circ$	55	70	-	deg	Fig.3	
CIE (x, y) Chromaticity	Red x	$\theta = 0^\circ$ $\phi = 0^\circ$ $T_a = 25^\circ\text{C}$	0.581	0.631	0.681	---	Fig.2	5
	Red y		0.290	0.340	0.390	---		
	Green x		0.293	0.343	0.393	---		
	Green y		0.563	0.613	0.663	---		
	Bule x		0.092	0.142	0.192	---		
	Bule y		0.035	0.085	0.135	---		
	White x		0.249	0.299	0.349	---		
	White y		0.290	0.340	0.390	---		

Note 1. Contrast Ratio(CR) is defined mathematically as For more information see FIG 2.

$$\text{Contrast Ratio} = \frac{\text{Average Surface Luminance with all white pixels (P1, P2, P3, P4, P5)}}{\text{Average Surface Luminance with all black pixels (P1, P2, P 3,P4, P5)}}$$

Note 2. Surface luminance is the LCD surface from the surface with all pixels displaying white. For more information see FIG 2.

$$L_v = \text{Average Surface Luminance with all white pixels (P1, P2, P 3, P4, P5)}$$

Note 3. The uniformity in surface luminance ,  $\delta$  WHITE is determined by measuring luminance at each test position 1 through 5, and then dividing the maximum luminance of 5 points luminance by minimum luminance of 5 points luminance. For more information see FIG 2.

$$\delta \text{ WHITE} = \frac{\text{Minimum Surface Luminance with all white pixels (P1, P2, P 3, P4, P5)}}{\text{Maximum Surface Luminance with all white pixels (P1, P2, P 3, P4, P5)}}$$

Note 4. Response time is the time required for the display to transition from White to black(Rise Time, Tr) and from black to white(Decay Time, Tf). For additional information see FIG 1. The test equipment is Autronic-Melchers's ConoScope. Series.

Note 5. CIE (x, y) chromaticity, The x, y value is determined by measuring luminance at each test position 1 through 5,and then make average value.

Note 6. Viewing angle is the angle at which the contrast ratio is greater than 2. For TFT module the contrast ratio is greater than 10. The angles are determined for the horizontal or x axis and the vertical or y axis with respect to the z axis which is normal to the LCD surface. For more information see FIG 3.

Note 7. For viewing angle and response time testing, the testing data is base on Autronic-Melchers's ConoScope. Series Instruments For contrast ratio, Surface Luminance, Luminance uniformity, CIE The test data is base on TOPCON's BM-5 photo detector.

Note 8. Definition of reflectance measurement system

Note 5) Reflectance is defined as follows:

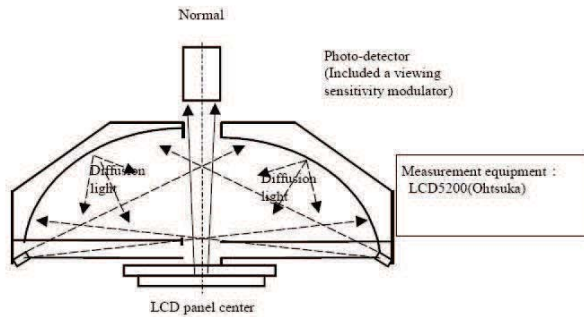

FIG. 1 The definition of Response Time

The response time is defined as the following figure and shall be measured by switching the input signal for “black” and “white”.

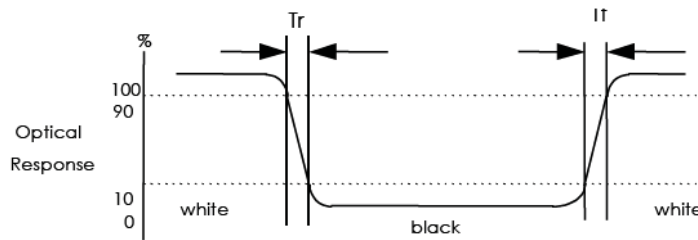

FIG. 2 Measuring method for Contrast ratio, surface luminance, Luminance uniformity , CIE (x, y) chromaticity

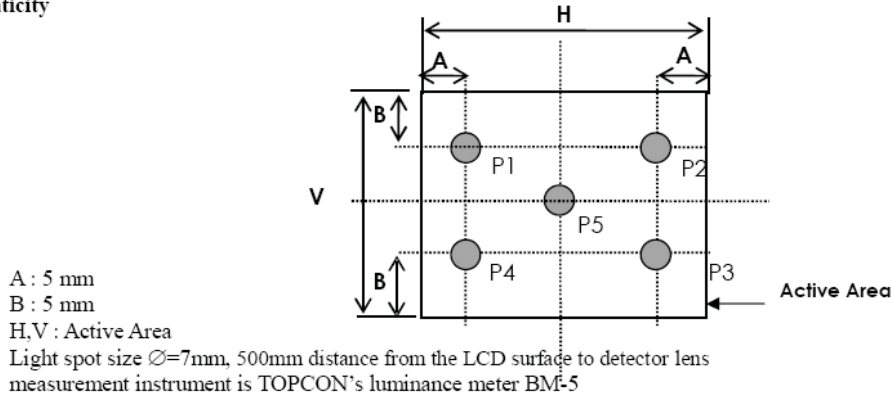
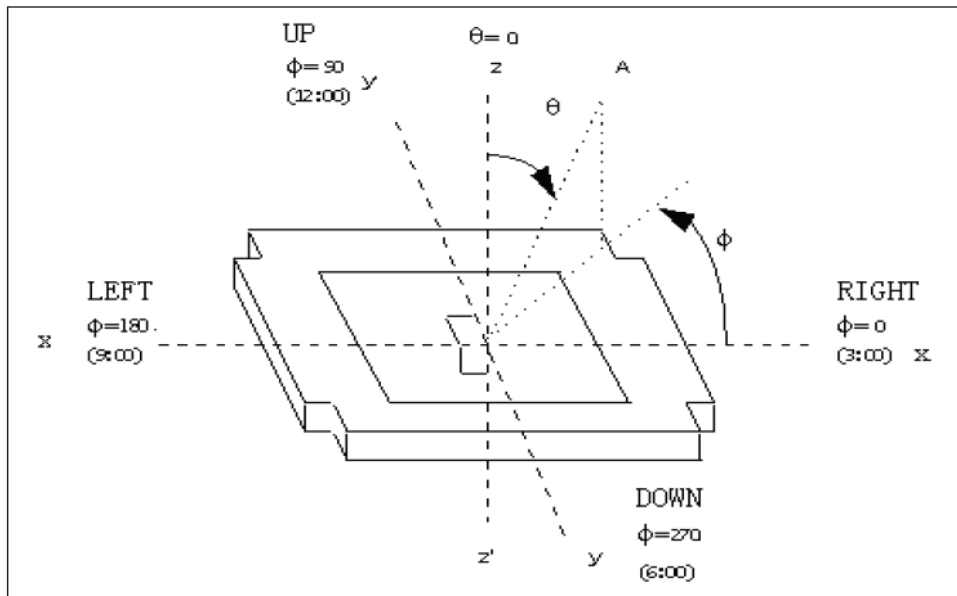

FIG. 3 The definition of viewing angle







## ■ INTERFACE DESCRIPTION

Pin No.	Symbol	I/O	Description
1	LEDK	I	Cathode for LED backlighting
2	LEDA1	I	Anode No.1 for LED backlighting
3	LEDA2	I	Anode No.2 for LED backlighting
4	LEDA3	I	Anode No.3 for LED backlighting
5	LEDA4	I	Anode No.4 for LED backlighting
6	IM0	I	Select Interface Mode ;Note1
7	IM1	I	
8	IM2	I	
9	IM3	I	
10	RESET	I	Reset pin
11	VSYNC	IO	Frame Synchronizing Signal For RGB Interface
12	HSYNC	IO	Line Synchronizing Signal For RGB Interface
13	DOTCLK	IO	Dot Clock Signal For RGB Interface
14	DE	IO	Data Enable Signal For RGB Interface
15   32	DB17   DB0	IO	DATA BUS If customer choose RGB interface, the data bus information is as below: DB0 -DB5 : B0-B5 DB6 -DB11: G0-G5 DB12-DB17 : R0-R5
33	SDO	IO	Serial Output Signal
34	SDI	IO	Serial Input Signal
35	RD	IO	Read execution control pin
36	WRX(D/CX)	IO	Write execution control pin ; Serial Register select s Signal
37	D/CX(SCL)	IO	Register select signal; Serial Interface Clock
38	CSX	IO	Chip Select Signal
39	TE	IO	Tearing effect out pin synchronize MPU to frame writng
40	VDDI	P	Logic power,provide with1.8/2.8V
41	VDDI	P	Logic power,provide with1.8/2.8V
42	VCI	P	Power Supply to the interface pins ,provide with 2.8V
43	GND	G	Ground
44	NC	-	No connection
45	NC	-	No connection
46	NC	-	No connection
47	NC	-	No connection
48	GND	O	Ground
49	GND	O	Ground
50	GND	-	Ground



NOTE1:

IM3	IM2	IM1	IM0	MCU-Interface Mode	Pins in use	
					Register/Content	GRAM
0	0	0	0	8080 MCU 8-bit bus interface I	D[7:0]	D[7:0],WRX,RDX,CSX,D/CX
0	0	0	1	8080 MCU 16-bit bus interface I	D[7:0]	D[15:0],WRX,RDX,CSX,D/CX
0	0	1	0	8080 MCU 9-bit bus interface I	D[7:0]	D[8:0],WRX,RDX,CSX,D/CX
0	0	1	1	8080 MCU 18-bit bus interface I	D[7:0]	D[17:0],WRX,RDX,CSX,D/CX
0	1	0	1	3-wire 9-bit data serial interface I	SCL,SDA,CSX	
0	1	1	0	4-wire 8-bit data serial interface I	SCL,SDA,D/CX,CSX	
1	0	0	0	8080 MCU 16-bit bus interface II	D[8:1]	D[17:10],D[8:1],WRX,RDX,CSX,D/CX
1	0	0	1	8080 MCU 8-bit bus interface II	D[17:10]	D[17:10],WRX,RDX,CSX,D/CX
1	0	1	0	8080 MCU 18-bit bus interface II	D[8:1]	D[17:0],WRX,RDX,CSX,D/CX
1	0	1	1	8080 MCU 9-bit bus interface II	D[17:10]	D[17:9],WRX,RDX,CSX,D/CX
1	1	0	1	3-wire 9-bit data serial interface II	SCL,SDI,SDO, CSX	
1	1	1	0	4-wire 8-bit data serial interface II	SCL,SDI,D/CX,SDO, CSX	

## APPLICATION NOTES

### 1. AC Characteristics

#### 1.1 Display Parallel 18/16/9/8-bit Interface Timing Characteristics (8080- I system)

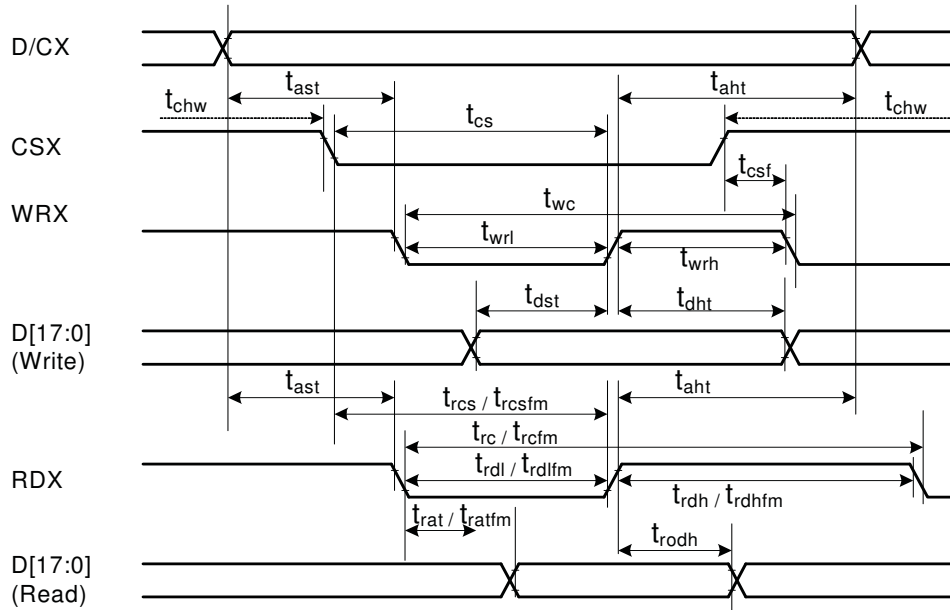

Signal	Symbol	Parameter	min	max	Unit	Description
DCX	$t_{ast}$	Address setup time	0	-	ns	
	$t_{ah}$	Address hold time (Write/Read)	0	-	ns	
CSX	$t_{chw}$	CSX "H" pulse width	0	-	ns	
	$t_{cs}$	Chip Select setup time (Write)	15	-	ns	
	$t_{rcs}$	Chip Select setup time (Read ID)	45	-	ns	
	$t_{rcsfm}$	Chip Select setup time (Read FM)	355	-	ns	
	$t_{csf}$	Chip Select Wait time (Write/Read)	10	-	ns	
WRX	$t_{wc}$	Write cycle	66	-	ns	
	$t_{wrh}$	Write Control pulse H duration	15	-	ns	
	$t_{wrl}$	Write Control pulse L duration	15	-	ns	
RDX (FM)	$t_{rcfm}$	Read Cycle (FM)	450	-	ns	
	$t_{rdhfm}$	Read Control H duration (FM)	90	-	ns	
	$t_{rdlfm}$	Read Control L duration (FM)	355	-	ns	
RDX (ID)	$t_{rc}$	Read cycle (ID)	160	-	ns	
	$t_{rdh}$	Read Control pulse H duration	90	-	ns	
	$t_{rdl}$	Read Control pulse L duration	45	-	ns	
D[17:0], D[15:0], D[8:0], D[7:0]	$t_{dst}$	Write data setup time	10	-	ns	For maximum CL=30pF For minimum CL=8pF
	$t_{dht}$	Write data hold time	10	-	ns	
	$t_{rat}$	Read access time	-	40	ns	
	$t_{ratfm}$	Read access time	-	340	ns	
	$t_{rodh}$	Read output disable time	20	80	ns	

Note:  $T_a = -30$  to  $70$  °C,  $V_{DDI} = 1.65V$  to  $3.3V$ ,  $V_{CI} = 2.5V$  to  $3.3V$ ,  $V_{SS} = 0V$

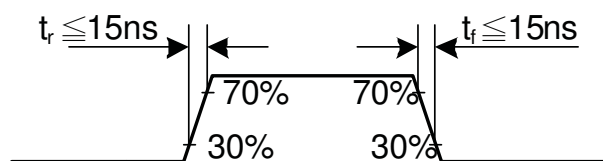

CSX timings :

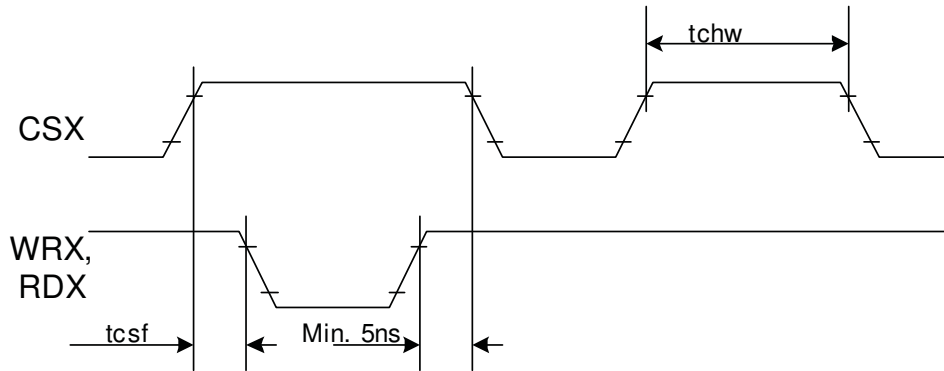

*Note: Logic high and low levels are specified as 30% and 70% of VDDI for Input signals.*

Write to read or read to write timings:

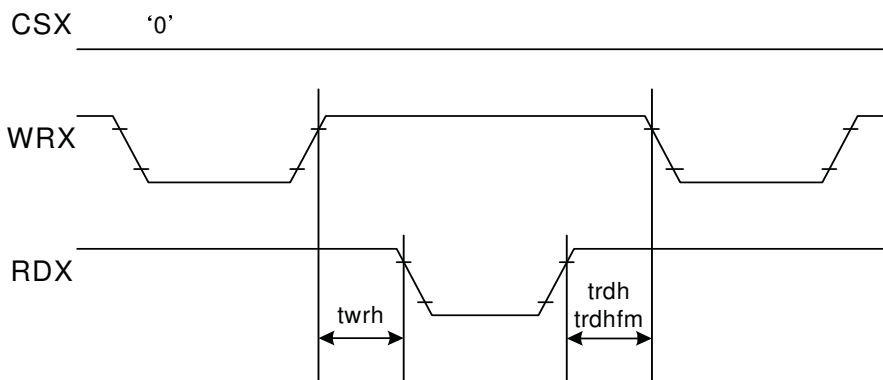

*Note: Logic high and low levels are specified as 30% and 70% of VDDI for Input signals.*

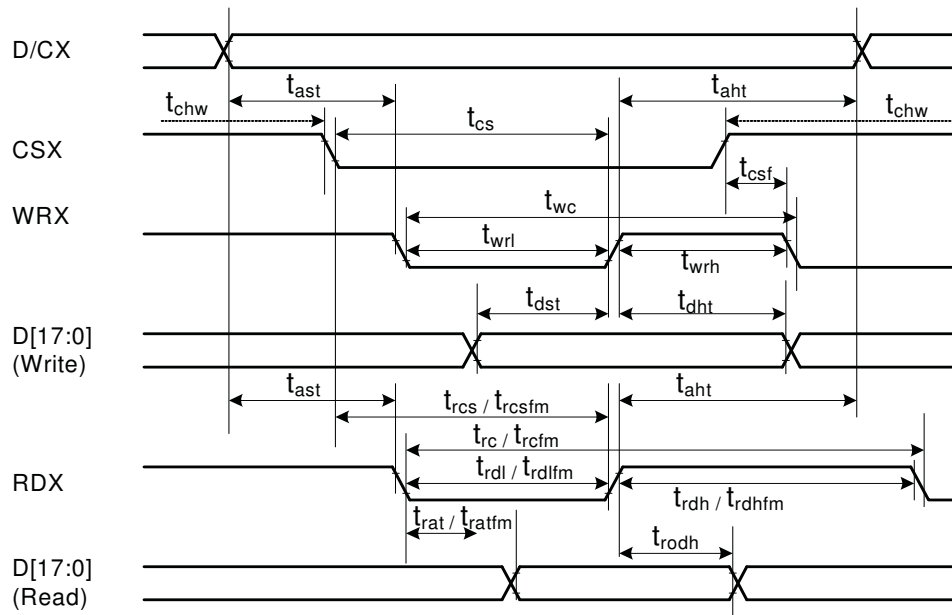
**1.2 Display Parallel 18/16/9/8-bit Interface Timing Characteristics(8080- II system)**

Signal	Symbol	Parameter	min	max	Unit	Description
DCX	t <sub>ast</sub>	Address setup time	0	-	ns	
	t <sub>ah</sub>	Address hold time (Write/Read)	0	-	ns	
CSX	t <sub>chw</sub>	CSX "H" pulse width	0	-	ns	
	t <sub>cs</sub>	Chip Select setup time (Write)	15	-	ns	
	t <sub>rcs</sub>	Chip Select setup time (Read ID)	45	-	ns	
	t <sub>rcsfm</sub>	Chip Select setup time (Read FM)	355	-	ns	
	t <sub>csf</sub>	Chip Select Wait time (Write/Read)	10	-	ns	
WRX	t <sub>wc</sub>	Write cycle	66	-	ns	
	t <sub>wrh</sub>	Write Control pulse H duration	15	-	ns	
	t <sub>wrl</sub>	Write Control pulse L duration	15	-	ns	
RDX (FM)	t <sub>rcfm</sub>	Read Cycle (FM)	450	-	ns	
	t <sub>rdhfm</sub>	Read Control H duration (FM)	90	-	ns	
	t <sub>rdlfm</sub>	Read Control L duration (FM)	355	-	ns	
RDX (ID)	t <sub>rc</sub>	Read cycle (ID)	160	-	ns	
	t <sub>rdh</sub>	Read Control pulse H duration	90	-	ns	
	t <sub>rdl</sub>	Read Control pulse L duration	45	-	ns	
D[17:0], D[17:10]&D[8:1], D[17:10], D[17:9]	t <sub>dst</sub>	Write data setup time	10	-	ns	For maximum CL=30pF For minimum CL=8pF
	t <sub>dht</sub>	Write data hold time	10	-	ns	
	t <sub>rat</sub>	Read access time	-	40	ns	
	t <sub>ratfm</sub>	Read access time	-	340	ns	
	t <sub>rodh</sub>	Read output disable time	20	80	ns	

Note:  $T_a = -30$  to  $70$  °C,  $V_{DDI}=1.65V$  to  $3.3V$ ,  $V_{CI}=2.5V$  to  $3.3V$ ,  $V_{SS}=0V$ .

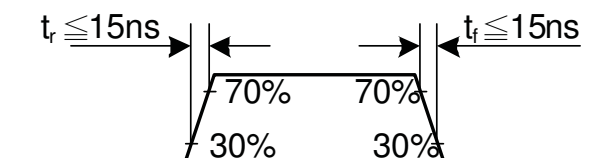

CSX timings :

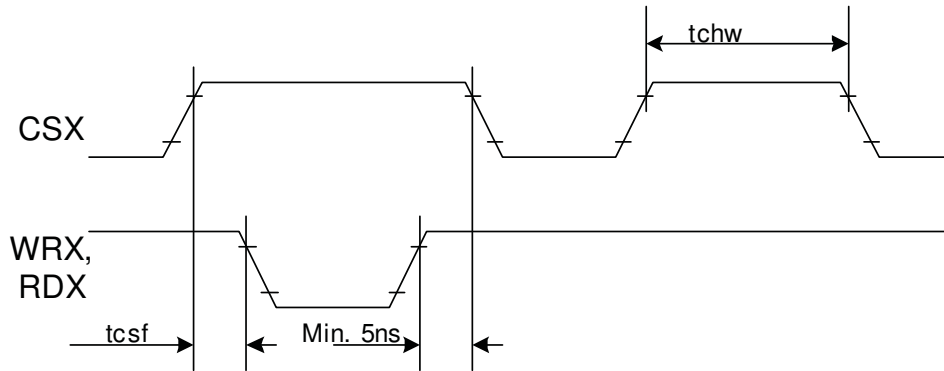

Note: Logic high and low levels are specified as 30% and 70% of VDDI for Input signals.

Write to read or read to write timings:

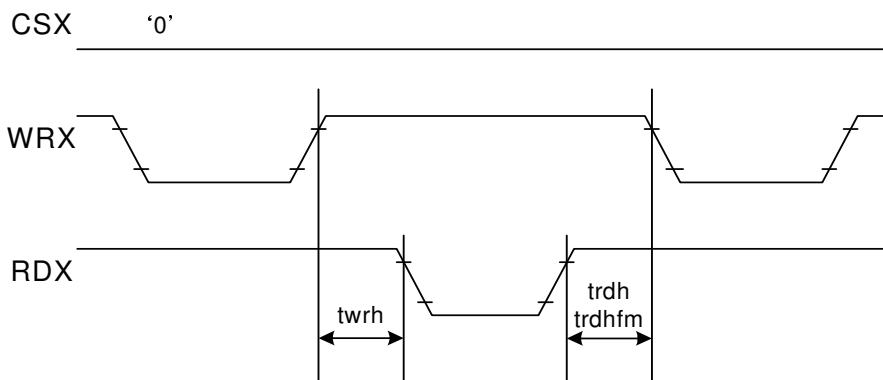

Note: Logic high and low levels are specified as 30% and 70% of VDDI for Input signals.

### 1.3 Display Serial Interface Timing Characteristics (3-line SPI system)

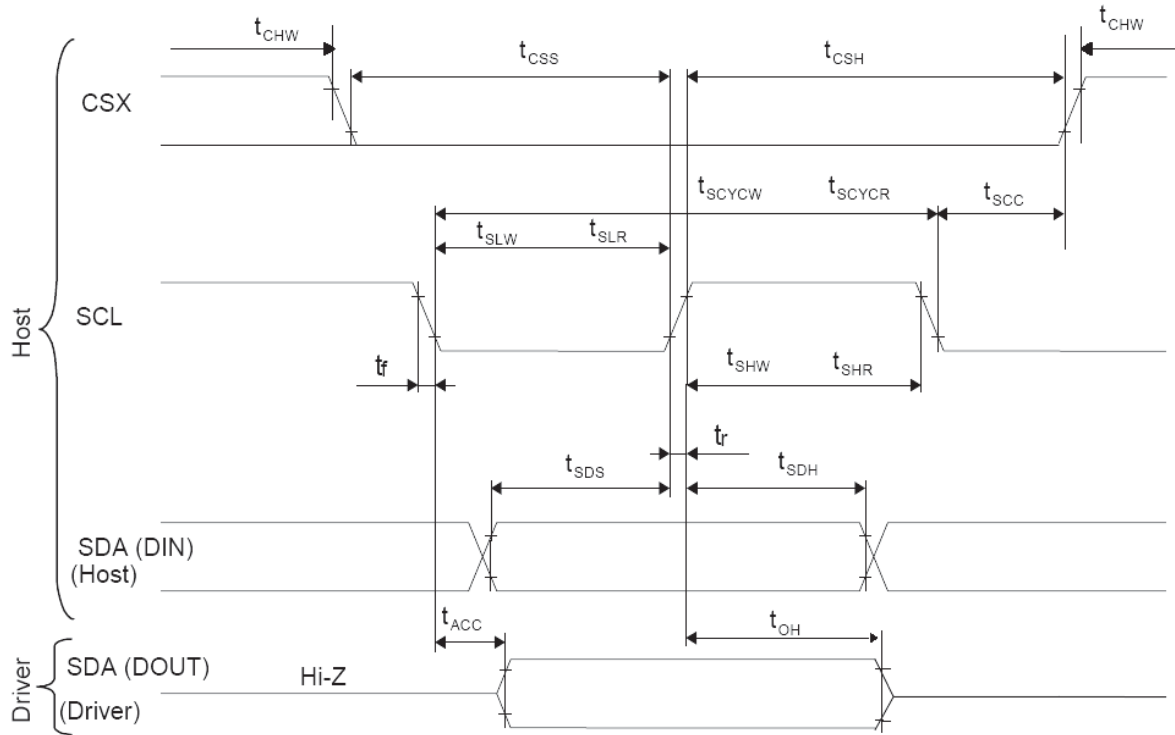

Signal	Symbol	Parameter	min	max	Unit	Description
SCL	$t_{scycw}$	Serial Clock Cycle (Write)	100	-	ns	
	$t_{shw}$	SCL "H" Pulse Width (Write)	40	-	ns	
	$t_{slw}$	SCL "L" Pulse Width (Write)	40	-	ns	
	$t_{scycr}$	Serial Clock Cycle (Read)	150	-	ns	
	$t_{shr}$	SCL "H" Pulse Width (Read)	60	-	ns	
	$t_{slr}$	SCL "L" Pulse Width (Read)	60	-	ns	
SDA / SDI (Input)	$t_{sds}$	Data setup time (Write)	30	-	ns	
	$t_{sdh}$	Data hold time (Write)	30	-	ns	
SDA / SDO (Output)	$t_{acc}$	Access time (Read)	10	-	ns	
	$t_{oh}$	Output disable time (Read)	10	50	ns	
CSX	$t_{scc}$	SCL-CSX	20	-	ns	
	$t_{chw}$	CSX "H" Pulse Width	40	-	ns	
	$t_{css}$	CSX-SCL Time	60	-	ns	
	$t_{csh}$		65	-	ns	

Note:  $T_a = 25\text{ }^\circ\text{C}$ ,  $V_{DDI}=1.65\text{V to }3.3\text{V}$ ,  $V_{CI}=2.5\text{V to }3.3\text{V}$ ,  $AGND=V_{SS}=0\text{V}$

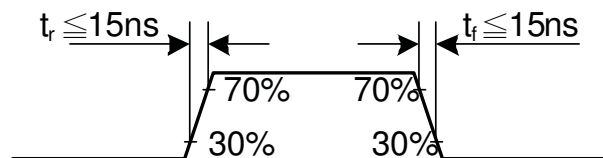

### 1.4 Display Serial Interface Timing Characteristics (4-line SPI system)

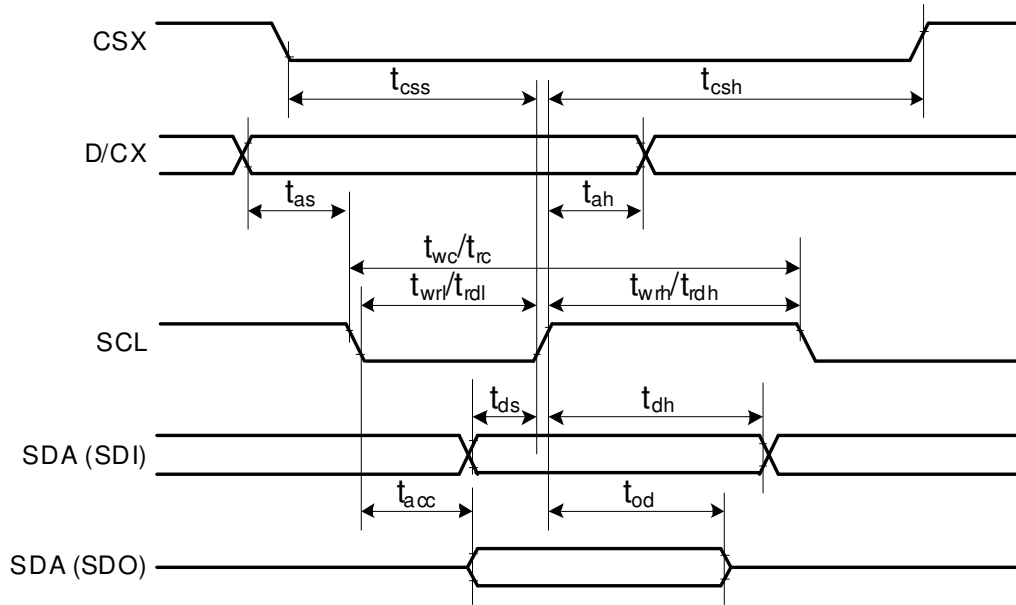

Signal	Symbol	Parameter	min	max	Unit	Description
CSX	$t_{css}$	Chip select time (Write)	40	-	ns	
	$t_{csh}$	Chip select hold time (Read)	40	-	ns	
SCL	$t_{wc}$	Serial clock cycle (Write)	100	-	ns	
	$t_{wrh}$	SCL "H" pulse width (Write)	40	-	ns	
	$t_{wrl}$	SCL "L" pulse width (Write)	40	-	ns	
	$t_{rc}$	Serial clock cycle (Read)	150	-	ns	
	$t_{rdh}$	SCL "H" pulse width (Read)	60	-	ns	
D/CX	$t_{rdl}$	SCL "L" pulse width (Read)	60	-	ns	
	$t_{as}$	D/CX setup time	10	-		
SDA / SDI (Input)	$t_{ah}$	D/CX hold time (Write / Read)	10	-		
	$t_{ds}$	Data setup time (Write)	30	-	ns	
SDA / SDO (Output)	$t_{dh}$	Data hold time (Write)	30	-	ns	
	$t_{acc}$	Access time (Read)	10	-	ns	For maximum $CL=30pF$ For minimum $CL=8pF$
$t_{od}$	Output disable time (Read)	10	50	ns		

Note:  $T_a = 25\text{ }^\circ\text{C}$ ,  $V_{DDI}=1.65\text{V to }3.3\text{V}$ ,  $V_{CI}=2.5\text{V to }3.3\text{V}$ ,  $AGND=VSS=0\text{V}$

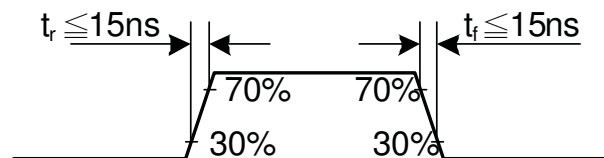



### 1.5 Parallel 18/16/6-bit RGB Interface Timing Characteristics

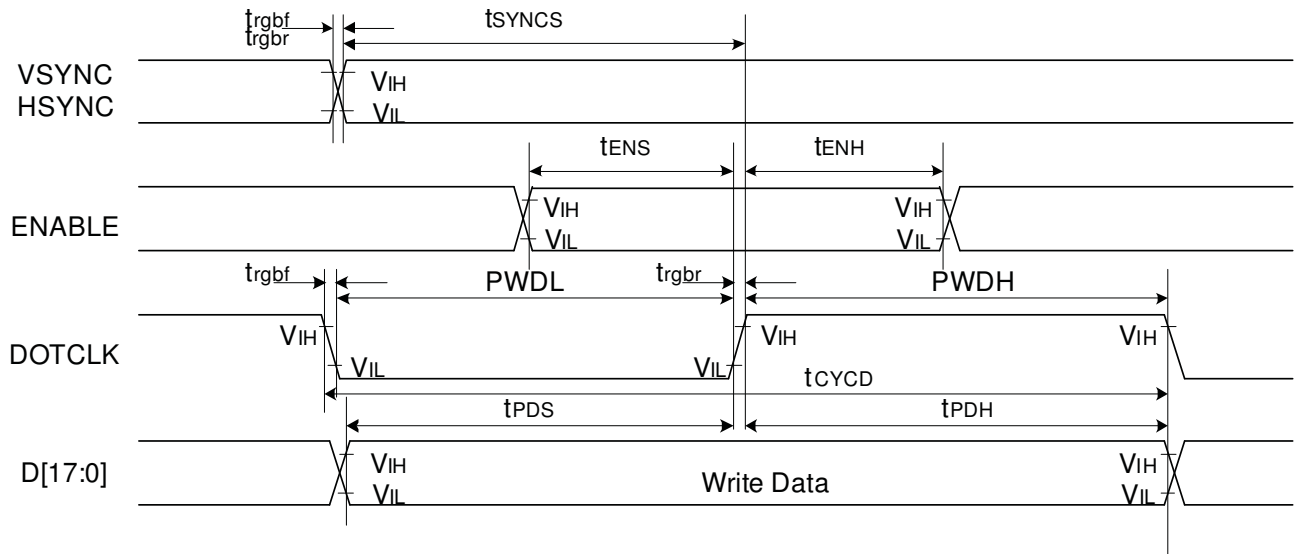

Signal	Symbol	Parameter	min	max	Unit	Description	
VSYNC / HSYNC	$t_{SYNCS}$	VSYNC/HSYNC setup time	15	-	ns	18/16-bit bus RGB interface mode	
	$t_{SYNCH}$	VSYNC/HSYNC hold time	15	-	ns		
DE	$t_{ENS}$	DE setup time	15	-	ns		
	$t_{ENH}$	DE hold time	15	-	ns		
D[17:0]	$t_{POS}$	Data setup time	15	-	ns		
	$t_{PDH}$	Data hold time	15	-	ns		
DOTCLK	PWDH	DOTCLK high-level period	15	-	ns		
	PWDL	DOTCLK low-level period	15	-	ns		
	$t_{CYCD}$	DOTCLK cycle time	100	-	ns		
	$t_{rgbr}, t_{rgbf}$	DOTCLK,HSYNC,VSYNC rise/fall time	-	15	ns		
VSYNC / HSYNC	$t_{SYNCS}$	VSYNC/HSYNC setup time	15	-	ns		6-bit bus RGB interface mode
	$t_{SYNCH}$	VSYNC/HSYNC hold time	15	-	ns		
DE	$t_{ENS}$	DE setup time	15	-	ns		
	$t_{ENH}$	DE hold time	15	-	ns		
D[17:0]	$t_{POS}$	Data setup time	15	-	ns		
	$t_{PDH}$	Data hold time	15	-	ns		
DOTCLK	PWDH	DOTCLK high-level pulse period	15	-	ns		
	PWDL	DOTCLK low-level pulse period	15	-	ns		
	$t_{CYCD}$	DOTCLK cycle time	100	-	ns		
	$t_{rgbr}, t_{rgbf}$	DOTCLK,HSYNC,VSYNC rise/fall time	-	15	ns		

Note:  $T_a = -30$  to  $70$  °C,  $V_{DDI}=1.65V$  to  $3.3V$ ,  $V_{CI}=2.5V$  to  $3.3V$ ,  $AGND=VSS=0V$

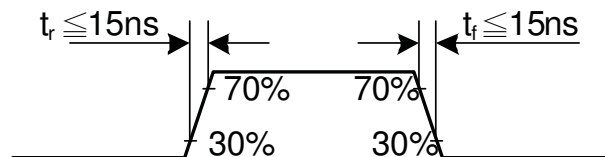



## INSTRUCTION DESCRIPTION

Regulative Command Set													
Command Function	D/CX	RDX	WRX	D17-8	D7	D6	D5	D4	D3	D2	D1	D0	Hex
No Operation	0	1	↑	XX	0	0	0	0	0	0	0	0	00h
Software Reset	0	1	↑	XX	0	0	0	0	0	0	0	1	01h
Read Display Identification Information	0	1	↑	XX	0	0	0	0	0	1	0	0	04h
	1	↑	1	XX	X	X	X	X	X	X	X	X	XX
	1	↑	1	XX	ID1 [7:0]							XX	
	1	↑	1	XX	ID2 [7:0]							XX	
	1	↑	1	XX	ID3 [7:0]							XX	
Read Display Status	0	1	↑	XX	0	0	0	0	1	0	0	1	09h
	1	↑	1	XX	X	X	X	X	X	X	X	X	XX
	1	↑	1	XX	D [31:25]							X	00
	1	↑	1	XX	X	D [22:20]			D [19:16]				61
	1	↑	1	XX	X	X	X	X	X	D [10:8]			00
	1	↑	1	XX	D [7:5]			X	X	X	X	X	00
Read Display Power Mode	0	1	↑	XX	0	0	0	0	1	0	1	0	0Ah
	1	↑	1	XX	X	X	X	X	X	X	X	X	XX
	1	↑	1	XX	D [7:2]						0	0	08
Read Display MADCTL	0	1	↑	XX	0	0	0	0	1	0	1	1	0Bh
	1	↑	1	XX	X	X	X	X	X	X	X	X	XX
	1	↑	1	XX	D [7:2]						0	0	00
Read Display Pixel Format	0	1	↑	XX	0	0	0	0	1	1	0	0	0Ch
	1	↑	1	XX	X	X	X	X	X	X	X	X	XX
	1	↑	1	XX	RIM	DPI [2:0]			X	DBI [2:0]			06
Read Display Image Format	0	1	↑	XX	0	0	0	0	1	1	0	1	0Dh
	1	↑	1	XX	X	X	X	X	X	X	X	X	XX
	1	↑	1	XX	X	X	X	X	X	D [2:0]			00
Read Display Signal Mode	0	1	↑	XX	0	0	0	0	1	1	1	0	0Eh
	1	↑	1	XX	X	X	X	X	X	X	X	X	XX
	1	↑	1	XX	D [7:2]						0	0	00
Read Display Self-Diagnostic Result	0	1	↑	XX	0	0	0	0	1	1	1	1	0Fh
	1	↑	1	XX	X	X	X	X	X	X	X	X	XX
	1	↑	1	XX	D [7:6]			X	X	X	X	X	00
Enter Sleep Mode	0	1	↑	XX	0	0	0	1	0	0	0	0	10h
Sleep OUT	0	1	↑	XX	0	0	0	1	0	0	0	1	11h
Partial Mode ON	0	1	↑	XX	0	0	0	1	0	0	1	0	12h
Normal Display Mode ON	0	1	↑	XX	0	0	0	1	0	0	1	1	13h
Display Inversion OFF	0	1	↑	XX	0	0	1	0	0	0	0	0	20h
Display Inversion ON	0	1	↑	XX	0	0	1	0	0	0	0	1	21h
Gamma Set	0	1	↑	XX	0	0	1	0	0	1	1	0	26h
	1	1	↑	XX	GC [7:0]							01	
Display OFF	0	1	↑	XX	0	0	1	0	1	0	0	0	28h
Display ON	0	1	↑	XX	0	0	1	0	1	0	0	1	29h
Column Address Set	0	1	↑	XX	0	0	1	0	1	0	1	0	2Ah
	1	1	↑	XX	SC [15:8]							XX	
	1	1	↑	XX	SC [7:0]							XX	
	1	1	↑	XX	EC [15:8]							XX	
	1	1	↑	XX	EC [7:0]							XX	
Page Address Set	0	1	↑	XX	0	0	1	0	1	0	1	1	2Bh
	1	1	↑	XX	SP [15:8]							XX	
	1	1	↑	XX	SP [7:0]							XX	
	1	1	↑	XX	EP [15:8]							XX	
	1	1	↑	XX	EP [7:0]							XX	



Memory Write	0	1	↑	XX	0	0	1	0	1	1	0	0	2Ch
	1	1	↑		D [17:0]								XX
Color SET	0	1	↑	XX	0	0	1	0	1	1	0	1	2Dh
	1	↑	1	XX								R00 [5:0]	XX
	1	↑	1	XX								Rnn [5:0]	XX
	1	↑	1	XX								R31 [5:0]	XX
	1	↑	1	XX								G00 [5:0]	XX
	1	↑	1	XX								Gnn [5:0]	XX
	1	↑	1	XX								G64 [5:0]	XX
	1	↑	1	XX								B00 [5:0]	XX
	1	↑	1	XX								Bnn [5:0]	XX
	1	↑	1	XX								B31 [5:0]	XX
Memory Read	0	1	↑	XX	0	0	1	0	1	1	1	0	2Eh
	1	↑	1	XX	X	X	X	X	X	X	X	X	XX
	1	↑	1		D [17:0]								XX
Partial Area	0	1	↑	XX	0	0	1	1	0	0	0	0	30h
	1	1	↑	XX								SR [15:8]	00
	1	1	↑	XX								SR [7:0]	00
	1	1	↑	XX								ER [15:8]	01
	1	1	↑	XX								ER [7:0]	3F
Vertical Scrolling Definition	0	1	↑	XX	0	0	1	1	0	0	1	1	33h
	1	1	↑	XX								TFA [15:8]	00
	1	1	↑	XX								TFA [7:0]	00
	1	1	↑	XX								VSA [15:8]	01
	1	1	↑	XX								VSA [7:0]	40
	1	1	↑	XX								BFA [15:8]	00
	1	1	↑	XX								BFA [7:0]	00
Tearing Effect Line OFF	0	1	↑	XX	0	0	1	1	0	1	0	0	34h
Tearing Effect Line ON	0	1	↑	XX	0	0	1	1	0	1	0	1	35h
	1	1	↑	XX	X	X	X	X	X	X	X	M	00
Memory Access Control	0	1	↑	XX	0	0	1	1	0	1	1	0	36h
	1	1	↑	XX	MY	MX	MV	ML	BGR	MH	X	X	00
Vertical Scrolling Start Address	0	1	↑	XX	0	0	1	1	0	1	1	1	37h
	1	1	↑	XX								VSP [15:8]	00
	1	1	↑	XX								VSP [7:0]	00
Idle Mode OFF	0	1	↑	XX	0	0	1	1	1	0	0	0	38h
Idle Mode ON	0	1	↑	XX	0	0	1	1	1	0	0	1	39h
Pixel Format Set	0	1	↑	XX	0	0	1	1	1	0	1	0	3Ah
	1	1	↑	XX	X							DPI [2:0]	66
Write Memory Continue	0	1	↑	XX	0	0	1	1	1	1	0	0	3Ch
	1	1	↑		D [17:0]								XX
Read Memory Continue	0	1	↑	XX	0	0	1	1	1	1	1	0	3Eh
	1	↑	1	XX	X	X	X	X	X	X	X	X	XX
	1	↑	1		D [17:0]								XX
Set Tear Scanline	0	1	↑	XX	0	1	0	0	0	1	0	0	44h
	1	1	↑	XX	X	X	X	X	X	X	X	STS [8]	00
	1	1	↑	XX								STS [7:0]	00
Get Scanline	0	1	↑	XX	0	1	0	0	0	1	0	1	45h
	1	↑	1	XX	X	X	X	X	X	X	X	X	XX
	1	↑	1	XX	X	X	X	X	X	X		GTS [9:8]	00
	1	↑	1	XX								GTS [7:0]	00
Write Display Brightness	0	1	↑	XX	0	1	0	1	0	0	0	1	51h
	1	1	↑	XX								DBV [7:0]	00



Read Display Brightness	0	1	↑	XX	0	1	0	1	0	0	1	0	52h
	1	↑	1	XX	X	X	X	X	X	X	X	X	XX
	1	↑	1	XX	DBV [7:0]								00
Write CTRL Display	0	1	↑	XX	0	1	0	1	0	0	1	1	53h
	1	1	↑	XX	X	X	BCTRL	X	DD	BL	X	X	00
Read CTRL Display	0	1	↑	XX	0	1	0	1	0	1	0	0	54h
	1	↑	1	XX	X	X	X	X	X	X	X	X	XX
	1	↑	1	XX	X	X	BCTRL	X	DD	BL	X	X	00
Write Content Adaptive Brightness Control	0	1	↑	XX	0	1	0	1	0	1	0	1	55h
	1	1	↑	XX	X	X	X	X	X	X	C [1:0]		00
Read Content Adaptive Brightness Control	0	1	↑	XX	0	1	0	1	0	1	1	0	56h
	1	↑	1	XX	X	X	X	X	X	X	X	X	XX
	1	↑	1	XX	X	X	X	X	X	X	C [1:0]		00
Write CABC Minimum Brightness	0	1	↑	XX	0	1	0	1	1	1	1	0	5Eh
	1	1	↑	XX	CMB [7:0]								00
Read CABC Minimum Brightness	0	1	↑	XX	0	1	0	1	0	1	1	1	5Fh
	1	↑	1	XX	X	X	X	X	X	X	X	X	XX
	1	↑	1	XX	CMB [7:0]								00
Read ID1	0	1	↑	XX	1	1	0	1	1	0	1	0	DAh
	1	↑	1	XX	X	X	X	X	X	X	X	X	XX
	1	↑	1	XX	Module's Manufacture [7:0]								XX
Read ID2	0	1	↑	XX	1	1	0	1	1	0	1	1	DBh
	1	↑	1	XX	X	X	X	X	X	X	X	X	XX
	1	↑	1	XX	LCD Module / Driver Version [7:0]								XX
Read ID3	0	1	↑	XX	1	1	0	1	1	1	0	0	DCh
	1	↑	1	XX	X	X	X	X	X	X	X	X	XX
	1	↑	1	XX	LCD Module / Driver ID [7:0]								XX

Extended Command Set													
Command Function	D/CX	RDX	WRX	D17-8	D7	D6	D5	D4	D3	D2	D1	D0	Hex
RGB Interface Signal Control	0	1	↑	XX	1	0	1	1	0	0	0	0	B0h
	1	1	↑	XX	ByPass_MODE	RCM [1:0]		X	VSPL	HSPL	DPL	EPL	40
Frame Control (In Normal Mode)	0	1	↑	XX	1	0	1	1	0	0	0	1	B1h
	1	1	↑	XX	X	X	X	X	X	X	DIVA [1:0]		00
	1	1	↑	XX	X	X	X	RTNA [4:0]					1B
Frame Control (In Idle Mode)	0	1	↑	XX	1	0	1	1	0	0	1	0	B2h
	1	1	↑	XX	X	X	X	X	X	X	DIVB [1:0]		00
	1	1	↑	XX	X	X	X	RTNB [4:0]					1B
Frame Control (In Partial Mode)	0	1	↑	XX	1	0	1	1	0	0	1	1	B3h
	1	1	↑	XX	X	X	X	X	X	X	DIVC [1:0]		00
	1	1	↑	XX	X	X	X	RTNC [4:0]					1B
Display Inversion Control	0	1	↑	XX	1	0	1	1	0	1	0	0	B4h
	1	1	↑	XX	X	X	X	X	X	NLA	NLB	NLC	02
Blanking Porch Control	0	1	↑	XX	1	0	1	1	0	1	0	1	B5h
	1	1	↑	XX	0	VFP [6:0]							02
	1	1	↑	XX	0	VBP [6:0]							02
	1	1	↑	XX	0	0	0	HFP [4:0]					0A
	1	1	↑	XX	0	0	0	HBP [4:0]					14



Display Function Control	0	1	↑	XX	1	0	1	1	0	1	1	0	B6h
	1	1	↑	XX	X	X	X	X	PTG [1:0]		PT [1:0]		0A
	1	1	↑	XX	REV	GS	SS	SM	ISC [3:0]			82	
	1	1	↑	XX	X	X	NL [5:0]						27
	1	1	↑	XX	X	X	PCDIV [5:0]						XX
Entry Mode Set	0	1	↑	XX	1	0	1	1	0	1	1	1	B7h
	1	1	↑	XX	X	X	X	X	DSTB	GON	DTE	GAS	07
Backlight Control 1	0	1	↑	XX	1	0	1	1	1	0	0	0	B8h
	1	1	↑	XX	X	X	X	X	X	X	X	X	XX
	1	1	↑	XX	X	X	X	X	TH_UI [3:0]			04	
Backlight Control 2	0	1	↑	XX	1	0	1	1	1	0	0	1	B9h
	1	1	↑	XX	X	X	X	X	X	X	X	X	XX
	1	1	↑	XX	TH_MV [3:0]			TH_ST [3:0]			B8		
Backlight Control 3	0	1	↑	XX	1	0	1	1	1	0	1	0	BAh
	1	1	↑	XX	X	X	X	X	X	X	X	X	XX
	1	1	↑	XX	X	X	X	X	DTH_UI [3:0]			04	
Backlight Control 4	0	1	↑	XX	1	0	1	1	1	0	1	1	BBh
	1	1	↑	XX	X	X	X	X	X	X	X	X	XX
	1	1	↑	XX	DTH_MV [3:0]			DTH_ST [3:0]			C9		
Backlight Control 5	0	1	↑	XX	1	0	1	1	1	1	0	0	BCh
	1	1	↑	XX	X	X	X	X	X	X	X	X	XX
	1	1	↑	XX	DIM2 [3:0]			X	DIM1 [2:0]			44	
Backlight Control 7	0	1	↑	XX	1	0	1	1	1	1	1	0	BEh
	1	1	↑	XX	PWM_DIV [7:0]							0F	
Backlight Control 8	0	1	↑	XX	1	0	1	1	1	1	1	1	BFh
	1	1	↑	XX	X	X	X	X	X	LEDONR	LEDONPOL	LEDPWMOPL	00
Power Control 1	0	1	↑	XX	1	1	0	0	0	0	0	0	C0h
	1	1	↑	XX	X	X	VRH [5:0]					26	
Power Control 2	0	1	↑	XX	1	1	0	0	0	0	0	1	C1h
	1	1	↑	XX	X	X	X	X	X	BT [2:0]			00
VCOM Control 1	0	1	↑	XX	1	1	0	0	0	1	0	1	C5h
	1	1	↑	XX	X	VMH [6:0]						31	
	1	1	↑	XX	X	VML [6:0]						3C	
VCOM Control 2	0	1	↑	XX	1	1	0	0	0	1	1	1	C7h
	1	1	↑	XX	nVM	VMF [6:0]						C0	
NV Memory Write	0	1	↑	XX	1	1	0	1	0	0	0	0	D0h
	1	1	↑	XX	X	X	X	X	X	PGM_ADR [2:0]			00
	1	1	↑	XX	PGM_DATA [7:0]							XX	
NV Memory Protection Key	0	1	↑	XX	1	1	0	1	0	0	0	1	D1h
	1	1	↑	XX	KEY [23:16]							55	
	1	1	↑	XX	KEY [15:8]							AA	
	1	1	↑	XX	KEY [7:0]							66	
NV Memory Status Read	0	1	↑	XX	1	1	0	1	0	0	1	0	D2h
	1	↑	1	XX	X	X	X	X	X	X	X	X	XX
	1	↑	1	XX	X	ID2_CNT [2:0]		X	ID1_CNT [2:0]		XX		
	1	↑	1	XX	BUSY	VMF_CNT [2:0]		X	ID3_CNT [2:0]		XX		



Read ID4	0	↑	1	XX	1	1	0	1	0	0	1	1	D3h
	1	↑	1	XX	X	X	X	X	X	X	X	X	XX
	1	↑	1	XX	0	0	0	0	0	0	0	0	00
	1	↑	1	XX	1	0	0	1	0	0	1	1	93
	1	↑	1	XX	0	1	0	0	0	0	0	1	41
Positive Gamma Correction	0	1	↑	XX	1	1	1	0	0	0	0	0	E0h
	1	1	↑	XX	X	X	X	X	VP0 [3:0]			08	
	1	1	↑	XX	X	X	VP1 [5:0]					0E	
	1	1	↑	XX	X	X	VP2 [5:0]					12	
	1	1	↑	XX	X	X	X	X	VP4 [3:0]			05	
	1	1	↑	XX	X	X	X	VP6 [4:0]				03	
	1	1	↑	XX	X	X	X	X	VP13 [3:0]			09	
	1	1	↑	XX	X	VP20 [6:0]					47		
	1	1	↑	XX	VP36 [3:0]			VP27 [3:0]			86		
	1	1	↑	XX	X	VP43 [6:0]					2B		
	1	1	↑	XX	X	X	X	X	VP50 [3:0]			0B	
	1	1	↑	XX	X	X	X	VP57 [4:0]				04	
	1	1	↑	XX	X	X	X	X	VP59 [3:0]			00	
	1	1	↑	XX	X	X	VP61 [5:0]					00	
	1	1	↑	XX	X	X	VP62 [5:0]					00	
1	1	↑	XX	X	X	X	X	VP63 [3:0]			00		
Negative Gamma Correction	0	1	↑	XX	1	1	1	0	0	0	0	1	E1h
	1	1	↑	XX	X	X	X	X	VN0 [3:0]			08	
	1	1	↑	XX	X	X	VN1 [5:0]					1A	
	1	1	↑	XX	X	X	VN2 [5:0]					20	
	1	1	↑	XX	X	X	X	X	VN4 [3:0]			07	
	1	1	↑	XX	X	X	X	VN6 [4:0]				0E	
	1	1	↑	XX	X	X	X	X	VN13 [3:0]			05	
	1	1	↑	XX	X	VN20 [6:0]					3A		
	1	1	↑	XX	VN36 [3:0]			VN27 [3:0]			8A		
	1	1	↑	XX	X	VN43 [6:0]					40		
	1	1	↑	XX	X	X	X	X	VN50 [3:0]			04	
	1	1	↑	XX	X	X	X	VN57 [4:0]				18	
	1	1	↑	XX	X	X	X	X	VN59 [3:0]			0F	
	1	1	↑	XX	X	X	VN61 [5:0]					3F	
	1	1	↑	XX	X	X	VN62 [5:0]					3F	
1	1	↑	XX	X	X	X	X	VN63 [3:0]			0F		
Digital Gamma Control 1	0	1	↑	XX	1	1	1	0	0	0	1	0	E2h
1 <sup>st</sup> Parameter	1	1	↑	XX	RCA0 [3:0]			BCA0 [3:0]			XX		
:	1	1	↑	XX	RCAx [3:0]			BCAx [3:0]			XX		
16 <sup>th</sup> Parameter	1	1	↑	XX	RCA15 [3:0]			BCA15 [3:0]			XX		
Digital Gamma Control 2	0	1	↑	XX	1	1	1	0	0	0	1	1	E3h
1 <sup>st</sup> Parameter	1	1	↑	XX	RFA0 [3:0]			BFA0 [3:0]			XX		
:	1	1	↑	XX	RFAx [3:0]			BFAX [3:0]			XX		
64 <sup>th</sup> Parameter	1	1	↑	XX	RFA63 [3:0]			BFA63 [3:0]			XX		
Interface Control	0	1	↑	XX	1	1	1	1	0	1	1	0	F6h
	1	1	↑	XX	MY_EOR	MX_EOR	MV_EOR	X	BGR_EOR	X	X	WEMODE	01
	1	1	↑	XX	X	X	EPF [1:0]		X	X	MDT [1:0]		00
	1	1	↑	XX	X	X	ENDIAN	X	DM [1:0]		RM	RIM	00

Note 1: Undefined commands are treated as NOP (00h) command.

Note 2: B0 to D9 and DE to FF are for factory use of display supplier. USER can decide if these commands are available or they are treated as NOP (00h) commands before shipping to USER. Default value is NOP (00h).

Note 3: Commands 10h, 12h, 13h, 26h, 28h, 29h, 30h, 36h (Bit B4 only), 38h and 39h are updated during V-SYNC when ILI9341V is in Sleep OUT mode to avoid abnormal visual effects. During Sleep IN mode, these commands are updated immediately. Read status (09h), Read display power mode (0Ah), Read display MADCTL (0Bh), Read display pixel format (0Ch), Read display image mode (0Dh), Read display signal mode (0Eh) and Read display self diagnostic result (0Fh) of these commands are updated immediately both in Sleep IN mode and Sleep OUT mode.

## ■ CTP SPECIFICATIONS

### 1. GENERAL SPECIFICATIONS

Item	Contents	Unit/Note
Type	Capacitive Type Touch Panel	/
Structure	Cover Glass + Sensor Glass + FPCA	/
Input Mode	Human's finger	/
Finger	10	/
Resolution	240 × 320	/
Cover Viewing Area (W) x	44.20 × 58.60	mm <sup>2</sup>
Sensor Active Area (W) x (H)	45.20 × 59.60	mm <sup>2</sup>
Hardness	7H	Pencil Hardness
Driver IC	FT5446	/

### 2. ABSOLUTE MAXIMUM RATINGS

Parameter	Symbol	Min	Typ	Max	Unit
Supply Voltage for Logic	VCC	2.8	3.3	3.6	V
Supply Current for Logic	ICC	—	12	14.5	mA

### 3. PIN DESCRIPTION

No.	Symbol	I/O	Description
1	TP_VCC	P	Power supply.
2	TP_/RES	I	Power supply.
3	TP_/INT	O	I2C clock signal.
4	TP_SDA	I/O	No connection.
5	TP_SCK	I	I2C data signal.
6	TP_VSS	P	Ground.

### 4. BLOCK DIAGRAM

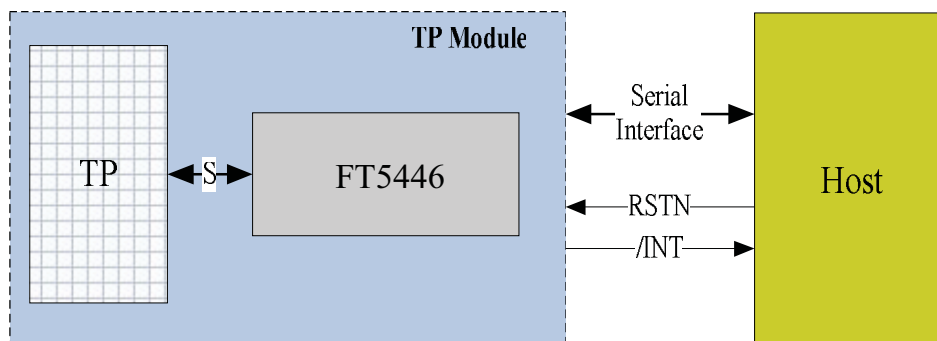

**5. CTP TIMING**

The I2C is always configured in the Slave mode. The data transfer format is shown in Figure 1-1.

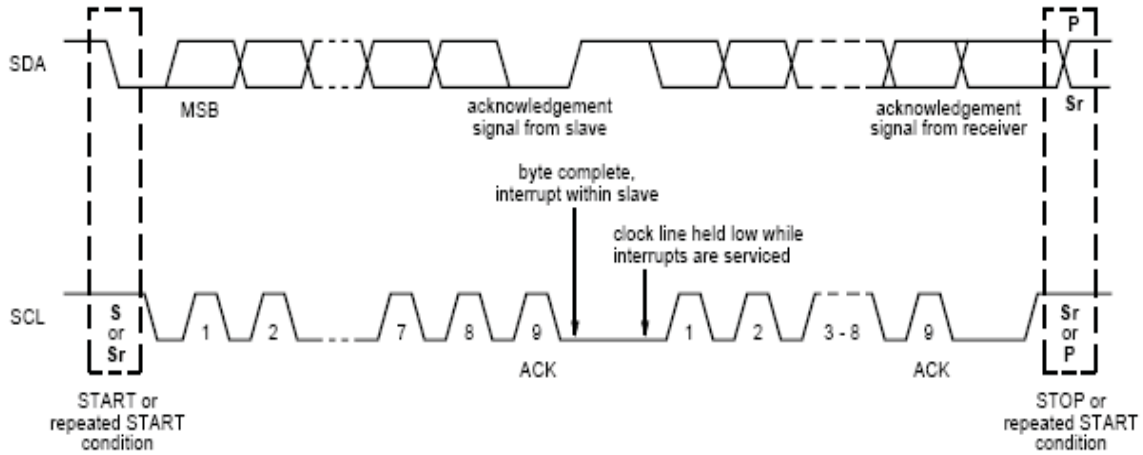

Figure 1-1 I2C Serial Data Transfer Format

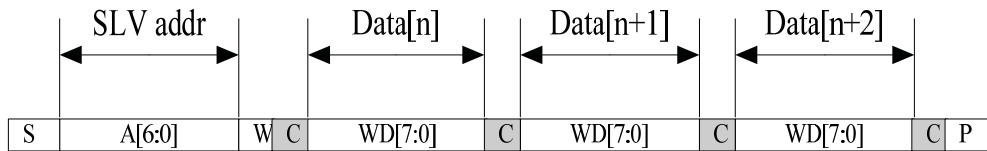

Figure 1-2 I2C master write, slave read

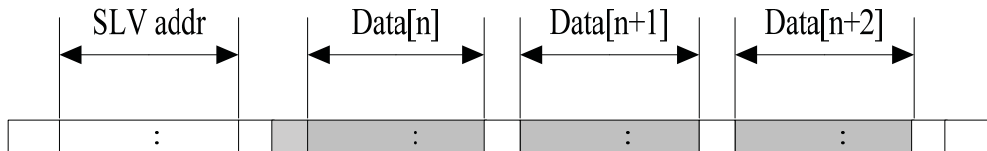

Figure 1-3 I2C master read, slave write

Table 1-1 lists the meanings of the mnemonics used in the above figures.

**Table 1-1 Mnemonics Description**

Mnemonics	Description
S	I2C Start or I2C Restart
A[6:0]	Slave address A[6:4]: 3'b011 A[3:0]: data bits are identical to those of I2CCON[7:4] register.
W	1'b0: Write
R	1'b1: Read
C	ACK
P	STOP: the indication of the end of a packet (if this bit is missing, S will indicate the end of the current packet and the beginning of the next packet)





I2C Interface Timing Characteristics is shown in Table 1-2.

**Table 1-2 I2C Timing Characteristics**

Parameter	Unit	Min	Max
SCL frequency	KHz	0	400
Bus free time between a STOP and START condition	us	4.7	\
Hold time (repeated) START condition	us	4.0	\
Data setup time	ns	250	\
Setup time for a repeated START condition	us	4.7	\
Setup Time for STOP condition	us	4.0	\

Note: More information pls refer to IC spec.

**■ RELIABILITY TEST**

No.	Test Item	Test Condition	Remarks
1	High Temperature Storage Test	80°C±2°C/96Hrs.	Note2
2	Low Temperature Storage Test	-30°C±2°C/96Hrs.	Note1,2
3	High Temperature Operation Test	70°C±2°C/96Hrs.	
4	Low Temperature Operation Test	-20°C±2°C/96Hrs.	Note1
5	High Temperature and High Humidity Operation Test	60±5°C, 90%RH 96Hrs.	Note1,2
6	Thermal Shock Test (Non-operating)	-30±2°C(30Min.)~25±2°C(5Min.)~80±2°C(30Min.) 10Cycles	
7	Vibration Test (Non-operating)	Frequency:10~55Hz Amplitude: 1.5mm Sweep Time: 11Mins Test Period: 6 Cycles For Each Direction Of X, Y, Z (Packing Condition)	
8	Shock Test (Non-operating)	100G, 6Ms Direction: ±X, ±Y, ±Z Cycle: 3 Times	
9	Electro Static Discharge Test	R:330Ω, C:150pF, 5points/panel Air: ±8KV, 5times; Contact:±4KV, 5times. (Environment:15°C ~35°C, 30%~60%, 86Kpa~106Kpa)	

Note 1: Without water condensation

Note 2: The function test shall be conducted after 2 hours storage at the room temperature and humidity after removed from the test chamber.

## ■ INSPECTION CRITERION

 OUTGOING QUALITY STANDARD	PAGE 1 OF 5
TITLE:FUNCTIONAL TEST & INSPECTION CRITERIA	

This specification is made to be used as the standard acceptance/rejection criteria for TFT module.

### 1. Sample plan

- 1.1 Lot size: Quantity per shipment lot per model
- 1.2 Sampling type: Normal inspection, Single sampling
- 1.3 Inspection level: II
- 1.4 Sampling table: MIL-STD-105D
- 1.5 Acceptable quality level (AQL)
  - Major defect: AQL=0.65
  - Minor defect: AQL=1.50

### 2. Inspection condition

#### 2.1 Ambient conditions

- a. Temperature: Room temperature  $25 \pm 5^\circ\text{C}$
- b. Humidity:  $(60 \pm 10)\% \text{RH}$
- c. Illumination: Single fluorescent lamp non-directive (300 to 700 Lux)

#### 2.2 Viewing distance

The distance between the LCD and the inspector's eyes shall be at least  $35 \pm 5\text{cm}$ .

#### 2.3 Viewing Angle

U/D:  $45^\circ / 45^\circ$ , L/R:  $45^\circ / 45^\circ$

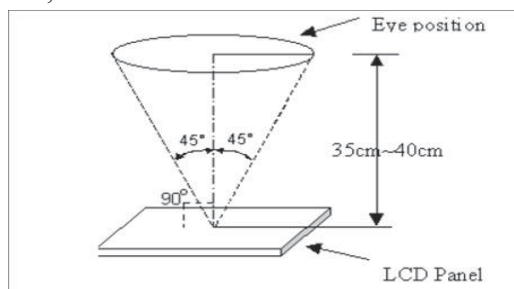

### 3. Definition of Inspection Item

#### 3.1 Definition of inspection zone in LCD Module (LCM)

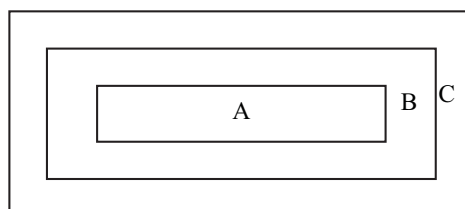



Fig.1 Inspection zones in an LCD

Zone A: Character/Digit area (Active area)

Zone B: Viewing area except Zone A (ZoneA+ZoneB=minimum Viewing area)

Zone C: Outside viewing area (invisible area after assembly in customer's product)

Note: As a general rule, visual defects in Zone C are permissible, when it is no trouble for

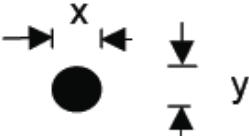
 OUTGOING QUALITY STANDARD	PAGE 2 OF 5		
TITLE:FUNCTIONAL TEST & INSPECTION CRITERIA			
quality and assembly of customer's product. If any visual defect in Zone C is impermissible, customers need to inform us by written.			
<b>4. Inspection standards</b>			
Defects are classified as major defects and minor defects according to the degree of defectiveness defined herein.			
<b>4.1 Major defect</b>			
Item No	Items to be inspected	Inspection Standard	
4.1.1	All functional defects	1) No display 2) Display abnormally 3) Short circuit 4) Line defect 5) Excess power consumption	
4.1.2	Missing	Missing function component	
4.1.3	Crack	Glass crack	
<b>4.2 Minor defect</b>			
Item No	Items to be inspected	Inspection standard	
4.2.1	Spot Defect Including Black spot White spot Pinhole Foreign particle Polarizer dirt	For dark/white spot is defined $\varphi = (x+y) / 2$ 	
		Size $\varphi$ (mm)	Acceptable Quantity
		$\varphi \leq 0.15$ 2mm(min) apart	Ignore
		$0.15 < \varphi \leq 0.25$ 5mm(min) apart	3
		$0.25 < \varphi$	Not allowed

OUTGOING QUALITY STANDARD		PAGE 3 OF 5	
TITLE:FUNCTIONAL TEST & INSPECTION CRITERIA			
4.2.2	Line Defect Including Black line White line Scratch	Define: 	
		Width(mm) Length(mm)	Acceptable Quantity
		$W \leq 0.05$ and $L \leq 10$	Ignore
		$0.05 < W \leq 0.08$ and $L \leq 10$ 3mm(min) apart	3
		$0.08 < W \leq 0.10$ and $L \leq 5$ 3mm(min) apart	1
	$0.10 < W$ or $10 < L$	Not allowed	
4.2.3	Polarizer Dent/Bubble	Size $\varphi$ (mm)	Acceptable Quantity
		$\varphi \leq 0.25$	Ignore
		Non visible area	Ignore
		$0.25 < \varphi \leq 0.40$ 5mm(min) apart	2
		$0.40 < \varphi$	Not allowed
4.2.4	Electrical Dot Defect	Bright and Black dot define: 	
		Inspection pattern: Full white, Full black, Red, green and blue screens	
		Item	Acceptable Quantity
		Black dot defect	2
		Bright dot defect	0
	Total Dot	2	

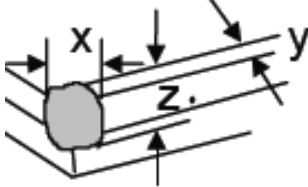
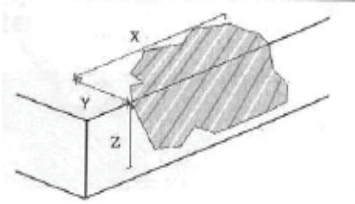
 OUTGOING QUALITY STANDARD		PAGE 4 OF 5	
TITLE:FUNCTIONAL TEST & INSPECTION CRITERIA			
4.2.5	Touch panel chips	1. Corner chips: 	
		Size(mm)	Acceptable Quantity
		$X \leq 3\text{mm}$ $Y \leq 3\text{mm}$ $Z \leq T$	Ignore T: Glass thickness X: Length Y: Width Z: thickness
		2. Side chips:	
		Size(mm)	Acceptable Quantity
		$X \leq 5\text{mm}$ $Y \leq 3\text{mm}$ $Z \leq T$	Ignore T: Glass thickness X: Length Y: Width Z: thickness
4.2.6	Touch panel Newton ring	Compare with limit sample	



 OUTGOING QUALITY STANDARD	PAGE 4 OF 5
TITLE:FUNCTIONAL TEST & INSPECTION CRITERIA	
<p>Note: 1. Dot defect is defined as the defective area of the dot area is larger than 50% of the dot area.</p> <p>2. The distance between black dot defects or black and bright dot defects should be more than 5mm apart. The distance between two bright dot defects should be more than 15 -mm apart.</p> <p>3. Polarizer bubble is defined as the bubble appears on active display area. The defect of polarizer bubble shall be ignored if the polarizer bubble appears on the outside of active display area.</p> <p>4. Mura is checker by 6% ND filter.</p> <p>5. Foreign particle on the surface of the LCM should be ignore.</p>	

## ■ PRECAUTIONS FOR USING LCD MODULES

### Handling Precautions

(1) The display panel is made of glass and polarizer. As glass is fragile. It tends to become or chipped during handling especially on the edges. Please avoid dropping or jarring. Do not subject it to a mechanical shock by dropping it or impact.

(2) If the display panel is damaged and the liquid crystal substance leaks out, be sure not to get any in your mouth. If the substance contacts your skin or clothes, wash it off using soap and water.

(3) Do not apply excessive force to the display surface or the adjoining areas since this may cause the color tone to vary. Do not touch the display with bare hands. This will stain the display area and degraded insulation between terminals (some cosmetics are determined to the polarizer).

(4) The polarizer covering the display surface of the LCD module is soft and easily scratched. Handle this polarizer carefully. Do not touch, push or rub the exposed polarizers with anything harder than an HB pencil lead (glass, tweezers, etc.). Do not put or attach anything on the display area to avoid leaving marks on. Condensation on the surface and contact with terminals due to cold will damage, stain or dirty the polarizer. After products are tested at low temperature they must be warmed up in a container before coming is contacting with room temperature air.

(5) If the display surface becomes contaminated, breathe on the surface and gently wipe it with a soft dry cloth. If it is heavily contaminated, moisten cloth with one of the following solvents

- Isopropyl alcohol
- Ethyl alcohol

Do not scrub hard to avoid damaging the display surface.

(6) Solvents other than those above-mentioned may damage the polarizer. Especially, do not use the following.

- Water
- Ketone
- Aromatic solvents

Wipe off saliva or water drops immediately, contact with water over a long period of time may cause deformation or color fading. Avoid contacting oil and fats.

(7) Exercise care to minimize corrosion of the electrode. Corrosion of the electrodes is accelerated by water droplets, moisture condensation or a current flow in a high-humidity environment.

(8) Install the LCD Module by using the mounting holes. When mounting the LCD module make sure it is free of twisting, warping and distortion. In particular, do not forcibly pull or bend the I/O cable or the backlight cable.

(9) Do not attempt to disassemble or process the LCD module.

(10) NC terminal should be open. Do not connect anything.

(11) If the logic circuit power is off, do not apply the input signals.

(12) Electro-Static Discharge Control, Since this module uses a CMOS LSI, the same careful attention should be paid to electrostatic discharge as for an ordinary CMOS IC. To prevent destruction of the elements by static electricity, be careful to maintain an optimum work environment.

- Before remove LCM from its packing case or incorporating it into a set, be sure the module and your body have the same electric potential. Be sure to ground the body when handling the LCD modules.

- Tools required for assembling, such as soldering irons, must be properly grounded. make certain the AC power source for the soldering iron does not leak. When using an electric screwdriver to attach LCM, the screwdriver should be of ground potentiality to minimize as much as possible any transmission of electromagnetic waves produced sparks coming from the commutator of the motor.

- To reduce the amount of static electricity generated, do not conduct assembling and other work under dry conditions. To reduce the generation of static electricity be careful that the air in the work is not too dried. A relative humidity of 50%-60% is recommended. As far as possible make the electric potential of your work clothes and that of the work bench the ground potential

- The LCD module is coated with a film to protect the display surface. Exercise care when peeling off this protective film since static electricity may be generated



(13) Since LCM has been assembled and adjusted with a high degree of precision, avoid applying excessive shocks to the module or making any alterations or modifications to it.

- Do not alter, modify or change the shape of the tab on the metal frame.
- Do not make extra holes on the printed circuit board, modify its shape or change the positions of components to be attached.
- Do not damage or modify the pattern writing on the printed circuit board.
- Absolutely do not modify the zebra rubber strip (conductive rubber) or heat seal connector.
- Except for soldering the interface, do not make any alterations or modifications with a soldering iron.
- Do not drop, bend or twist LCM.

**Handling precaution for LCM**

LCM is easy to be damaged.  
Please note below and be careful for handling!

**Correct handling:**



As above picture, please handle with anti-static gloves around LCM edges.

**Incorrect handling:**

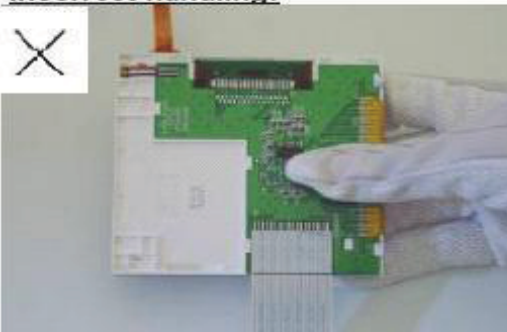

Please don't touch IC directly.

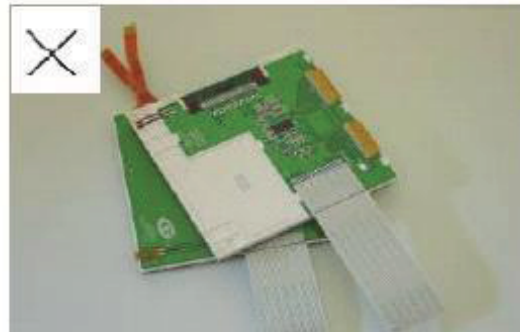

Please don't stack LCM.

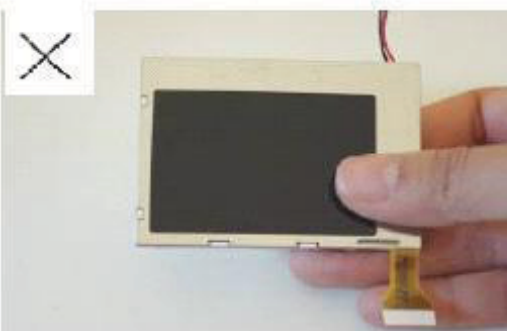

Please don't hold the surface of panel.

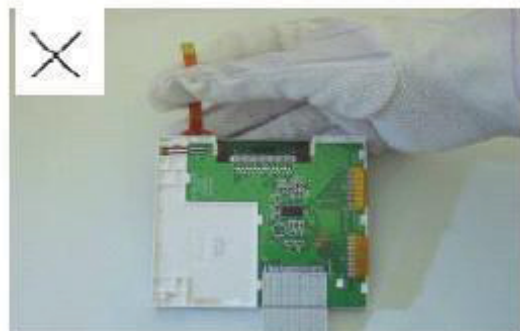

Please don't stretch interface of output, such as FPC cable.

**Handling precaution for LCD**

LCD is easy to be damaged.  
Please note below and be careful for handling!

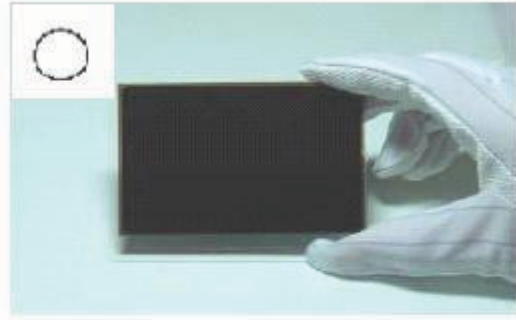
**Correct handling:**

As above photo, please handle with anti-static gloves around LCD edges.

**Incorrect handling:**

Please don't stack the LCDS.

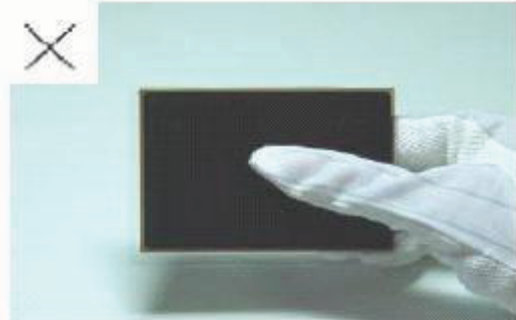

Please don't hold the surface of LCD.

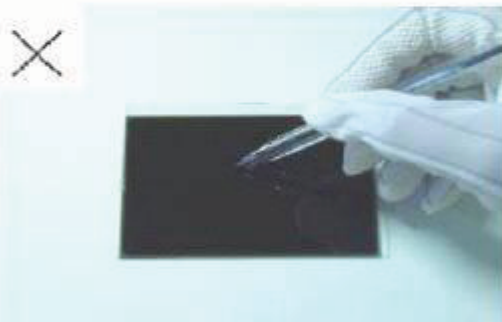

Please don't operate with sharp stick such as pens.

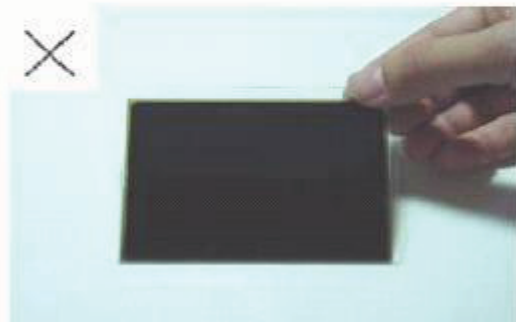

Please don't touch ITO glass without anti-static gloves.

### Storage Precautions

When storing the LCD modules, the following precaution is necessary.

- (1) Store them in a sealed polyethylene bag. If properly sealed, there is no need for the dessicant.
- (2) Store them in a dark place. Do not expose to sunlight or fluorescent light, keep the temperature between 0°C and 35°C, and keep the relative humidity between 40%RH and 60%RH.
- (3) The polarizer surface should not come in contact with any other objects. (We advise you to store them in the anti-static electricity container in which they were shipped.

#### Others

Liquid crystals solidify under low temperature (below the storage temperature range) leading to defective orientation or the generation of air bubbles (black or white). Air bubbles may also be generated if the module is subject to a low temperature.

If the LCD modules have been operating for a long time showing the same display patterns, the display patterns may remain on the screen as ghost images and a slight contrast irregularity may also appear. A normal operating status can be regained by suspending use for some time. It should be noted that this phenomenon does not adversely affect performance reliability.

To minimize the performance degradation of the LCD modules resulting from destruction caused by static electricity etc., exercise care to avoid holding the following sections when handling the modules.

- Exposed area of the printed circuit board.
- Terminal electrode sections.

### USING LCD MODULES

#### Installing LCD Modules

The hole in the printed circuit board is used to fix LCM as shown in the picture below. Attend to the following items when installing the LCM.

- (1) Cover the surface with a transparent protective plate to protect the polarizer and LC cell.

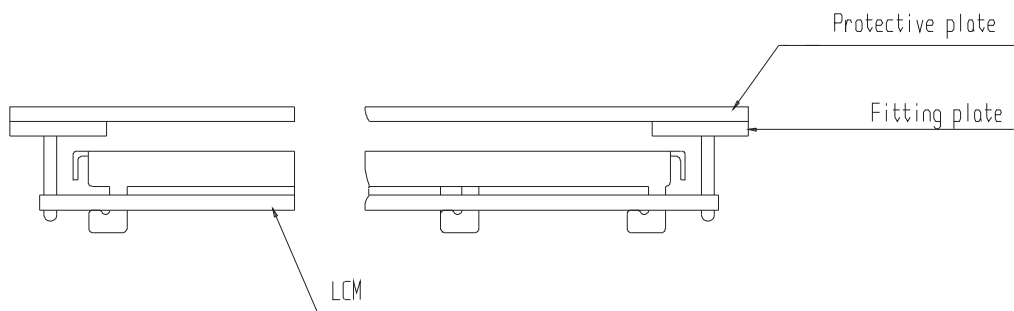

- (2) When assembling the LCM into other equipment, the spacer to the bit between the LCM and the fitting plate should have enough height to avoid causing stress to the module surface, refer to the individual specifications for measurements. The measurement tolerance should be  $\pm 0.1$  mm.

#### Precaution for assemble the module with BTB connector:

Please note the position of the male and female connector position, don't assemble or assemble like the method which the following picture shows

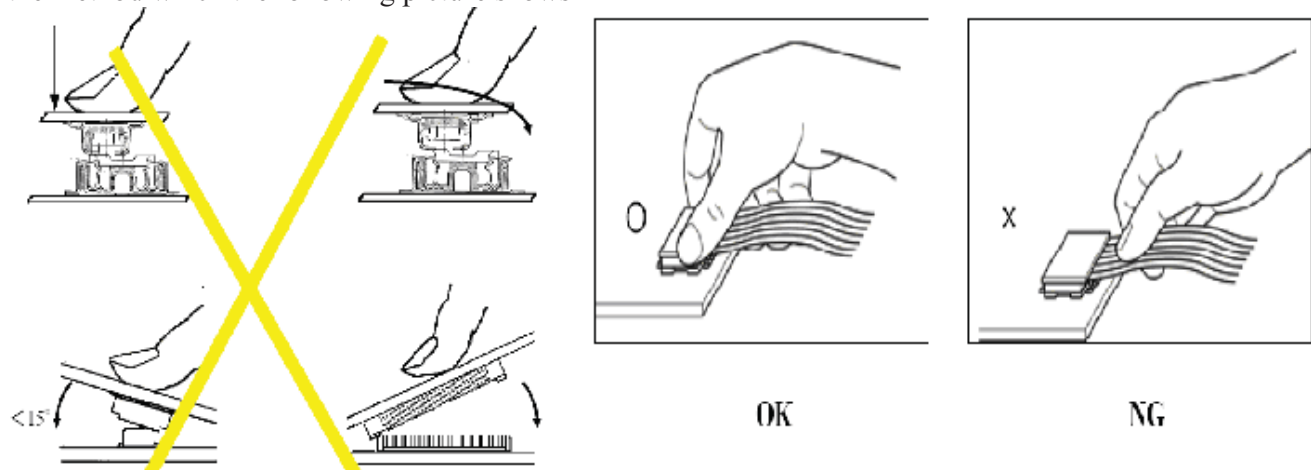

**Precaution for soldering to the LCM**

	Hand soldering	Machine drag soldering	Machine press soldering
No ROHS product	290°C ~350°C. Time : 3-5S.	330°C ~350°C. Speed : 4-8 mm/s.	300°C ~330°C. Time : 3-6S. Press: 0.8~1.2Mpa
ROHS product	340°C ~370°C. Time : 3-5S.	350°C ~370°C. Time : 4-8 mm/s.	330°C ~360°C. Time : 3-6S. Press: 0.8~1.2Mpa

(1) If soldering flux is used, be sure to remove any remaining flux after finishing to soldering operation. (This does not apply in the case of a non-halogen type of flux.) It is recommended that you protect the LCD surface with a cover during soldering to prevent any damage due to flux spatters.

(2) When soldering the electroluminescent panel and PC board, the panel and board should not be detached more than three times. This maximum number is determined by the temperature and time conditions mentioned above, though there may be some variance depending on the temperature of the soldering iron.

(3) When remove the electroluminescent panel from the PC board, be sure the solder has completely melted, the soldered pad on the PC board could be damaged.

**Precautions for Operation**

(1) Viewing angle varies with the change of liquid crystal driving voltage (VLCD). Adjust VLCD to show the best contrast.

(2) It is an indispensable condition to drive LCD's within the specified voltage limit since the higher voltage then the limit cause the shorter LCD life. An electrochemical reaction due to direct current causes LCD's undesirable deterioration, so that the use of direct current drive should be avoided.

(3) Response time will be extremely delayed at lower temperature than the operating temperature range and on the other hand at higher temperature LCD's show dark color in them. However those phenomena do not mean malfunction or out of order with LCD's, Which will come back in the specified operating temperature.

(4) If the display area is pushed hard during operation, the display will become abnormal. However, it will return to normal if it is turned off and then back on.

(5) A slight dew depositing on terminals is a cause for electro-chemical reaction resulting in terminal open circuit. Usage under the maximum operating temperature, 50%RH or less is required.

(6) Input each signal after the positive/negative voltage becomes stable.

(7) Please keep the temperature within specified range for use and storage. Polarization degradation, bubble generation or polarizer peel-off may occur with high temperature and high humidity.

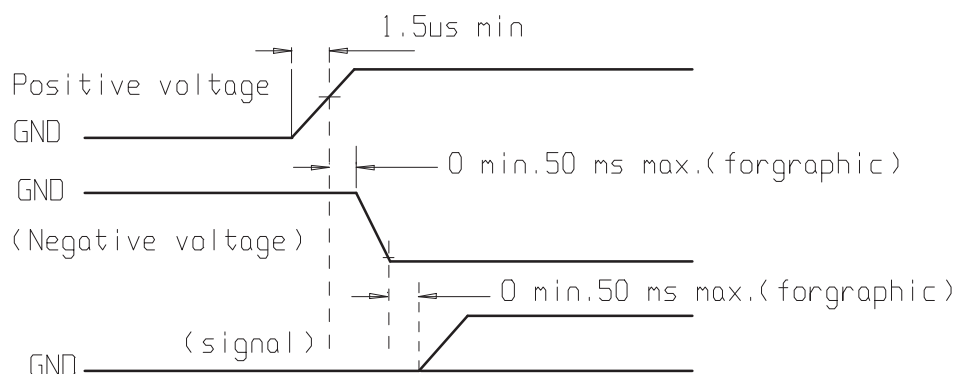

**Safety**

(1) It is recommended to crush damaged or unnecessary LCDs into pieces and wash them off with solvents such as acetone and ethanol, which should later be burned.

(2) If any liquid leaks out of a damaged glass cell and comes in contact with the hands, wash off thoroughly with soap and water.

**Limited Warranty**

Unless agreed between Multi-Inno and customer, Multi-Inno will replace or repair any of its LCD modules which are found to be functionally defective when inspected in accordance with Multi-Inno LCD acceptance standards (copies available upon request) for a period of one year from date of production. Cosmetic/visual defects must be returned to Multi-Inno within 90 days of shipment. Confirmation of such date shall be based on data code on product. The warranty liability of Multi-Inno limited to repair and/or replacement on the terms set forth above. Multi-Inno will not be responsible for any subsequent or consequential events.

**Return LCM under warranty**

No warranty can be granted if the precautions stated above have been disregarded. The typical examples of violations are :

- Broken LCD glass.
- PCB eyelet is damaged or modified.
- PCB conductors damaged.
- Circuit modified in any way, including addition of components.
- PCB tampered with by grinding, engraving or painting varnish.
- Soldering to or modifying the bezel in any manner.

Module repairs will be invoiced to the customer upon mutual agreement. Modules must be returned with sufficient description of the failures or defects. Any connectors or cable installed by the customer must be removed completely without damaging the PCB eyelet, conductors and terminals.

**■ PRIOR CONSULT MATTER**

- 1.①For Multi-Inno standard products, we keep the right to change material, process ... for improving the product property without notice on our customer.  
②For OEM products, if any change needed which may affect the product property, we will consult with our customer in advance.
2. If you have special requirement about reliability condition, please let us know before you start the test on our samples.