

## DAM-B1-B-N0-000-04-02

### 1. Explanation of Part Number:

**DAM – B1 - B – N0 - 000 - 04 - 02**  
 (1) (2) (3) (4) (5) (6) (7)

- (1) Product type: DAM-Dipole Antenna Module
  - (2) Appearance Series: B1
  - (3) Frequency: B=2.4G-2.5GHz
  - (4) Coaxial Cable Specification: N0: without cable
  - (5) Coaxial Cable Length: 000=Cable Length:0
  - (6) Connector Types: 04=SMA RP PLUG
  - (7) Suffix for special requirements: 02=Without Cable
- ※ RoHS Compliant

### 2. Electrical properties:

Item	Property
Frequency Range	2.4G-2.5GHz
Impedance	50 Ω (Typ.)
Antenna Gain	3.0+/-0.7 dBi
VSWR	2.5 max.

### 3. Test Data:

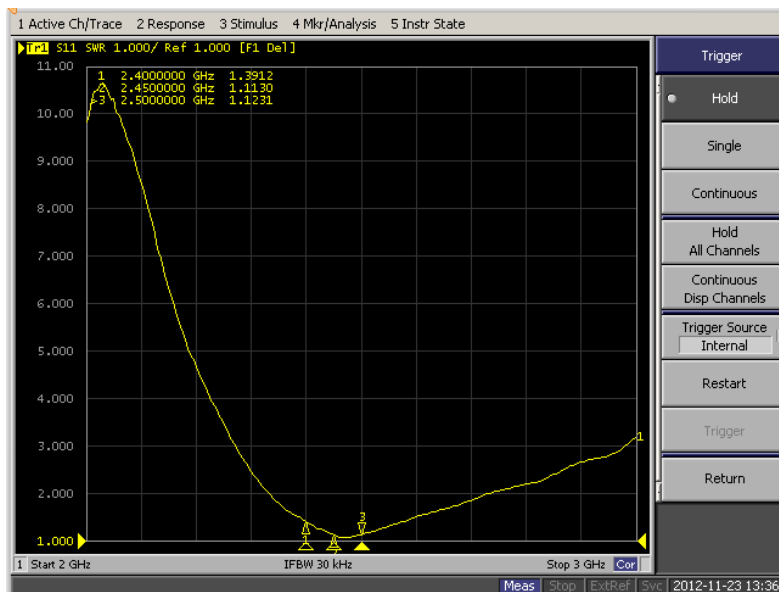

Frequency (GHz)	2.4	2.45	2.5
VSWR	1.39	1.11	1.12

4. Mechanical properties:

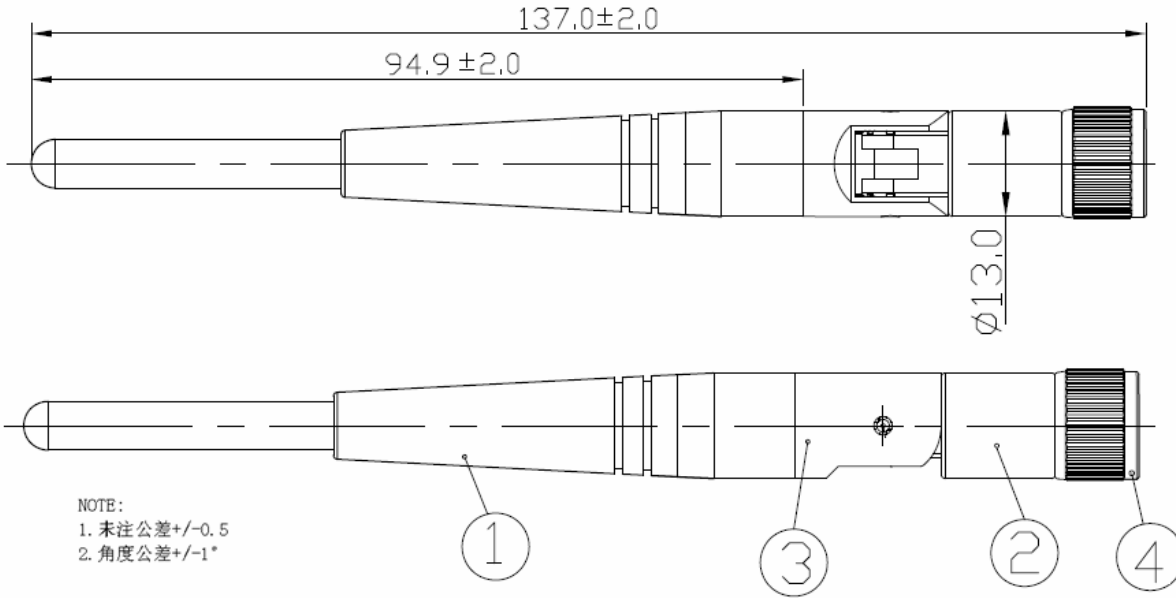

No	Description	Material	Finish
1	BODY-1	TPE	BLACK
2	BODY-2	ABS	BLACK
3	BODY-3	ABS	BLACK
4	Connector : SMA RP PLUG	CU	BLACK

5. Reliable test:

Test Item	Procedure	Requirement
1. Visual inspection and dimension check	Applicable methods using x 5 magnification	Follow specification
2. Rapaid changing of temperature	-40°C (30 minutes) to 90°C (30 minnutes) ; 24 cycles	After 2 hours recovery 1. No visible damage 2. Freq. Tol.:<± 5%
3. Damp Heat	24 hours at 60°C; 90 ~ 95% RH	After 2 hours recovery 1. No visible damage 2. Freq. Tol.:<± 5%
4. Endurance	24 hours at 90°C	After 2 hours recovery 1. No visible damage 2. Freq. Tol.:<± 5%