

ISM Band Chip Antenna For ACG-2505-A1-MF-S

1. Explanation of Part Number :

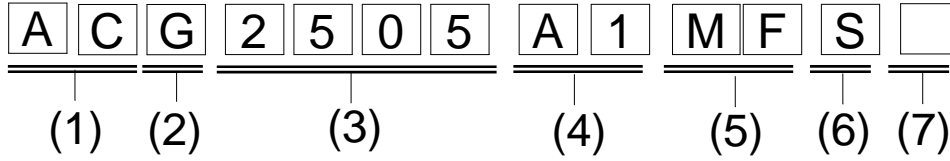

- (1) Product Type: Chip Antenna
- (2) Center Frequency/Band Code: G-ISM Band (858~870MHz)
- (3) Size Code: 25.0mm(length) x 5.0mm(width)
- (4) Design Revision Code: A1= Rev. 1
- (5) Series No.: MF=Monopole FR4
- (6) Special Code: S= RoHS Compliant
- (7) Suffix For Special Requirements

2. Electrical Specification :

Electrical Specification	
Frequency Band	858 ~ 870MHz
Polarization	Linear
Patten	Omni-Directional
Reef Impedance	50 ohm
Size	25mmx5.0mmx0.8mm
Peak Gain	2 dBi Typ.
Average Gain	-3.4 dBi Typ

* Test condition: Test board size 80*50mm

Matching circuit: Pi matching circuit will be required

3. Dimensions: (unit: mm)

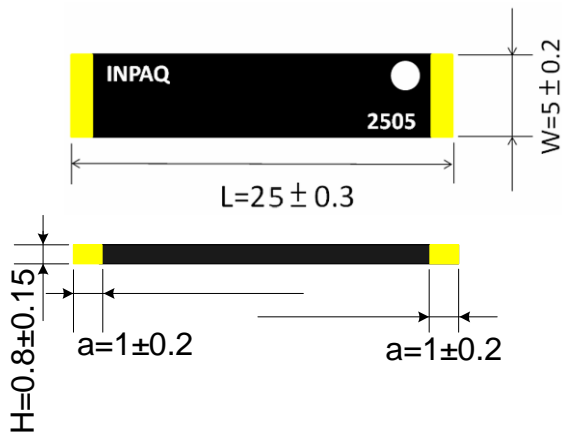

Mark	L	W	H	a
Dimensions	25.0±0.3	5.0±0.2	0.8±0.15	1.0±0.2

UNLESS OTHER SPECIFIED TOLERANCES ON :

X=± X.X=± X.XX=±
 ANGLES=± HOLEDIA=±



INPAQ TECHNOLOGY CO., LTD.

SCALE : xxxx

UNIT : mm

DRAWN BY: 游曉仔

CHECKED BY: 楊奇峯

DESIGNED BY: 陳威仁

APPROVED BY: 謝立庭

THIS DRAWINGS AND SPECIFICATIONS ARE THE PROPERTY OF INPAQ TECHNOLOGY CO.,LTD.AND SHALL NOT BE REPRODUCED OR USED AS THE BASIS FOR THE MANUFACTURE OR SALE OF APPARATUS OR DEVICES WITHOUT PERMISSION

TITLE : ISM Band Chip Antenna For
ACG-2505-A1-MF-S

DOCUMENT
NO.

ENS000036870

SPEC REV.

P3

4. The Picture of Test Board

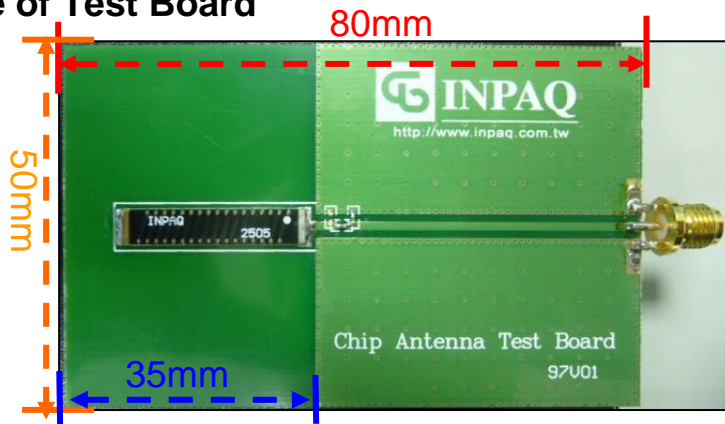

5. Measurement Data

VSWR

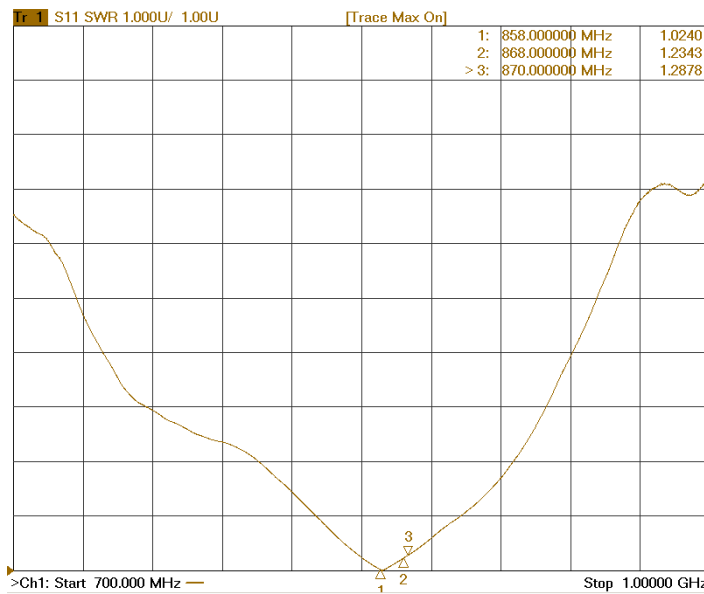

Frequency (Unit:MHz)	858	868	870
VSWR value	1.02	1.23	1.28

UNLESS OTHER SPECIFIED TOLERANCES ON :

X=± X.X=± X.XX=±
 ANGLES=± HOLEDIA=±



INPAQ TECHNOLOGY CO., LTD.

SCALE : xxxx

UNIT : mm

DRAWN BY: 游曉仔

CHECKED BY: 楊奇峯

DESIGNED BY: 陳威仁

APPROVED BY: 謝立庭

THIS DRAWINGS AND SPECIFICATIONS ARE THE PROPERTY OF INPAQ TECHNOLOGY CO.,LTD.AND SHALL NOT BE REPRODUCED OR USED AS THE BASIS FOR THE MANUFACTURE OR SALE OF APPARATUS OR DEVICES WITHOUT PERMISSION

TITLE : ISM Band Chip Antenna For
ACG-2505-A1-MF-S

DOCUMENT
NO.

ENS000036870

SPEC REV.
P3

6. RADIATION PATTERN

The Gain pattern was measuring in INPAQ's FAR-field chamber. DUT will be placed on the table of rotator, a standard horn antenna and Vector Network Analyzer was using to collected data. (Please contact to INPAQ for more detail)

- Measuring factors definition

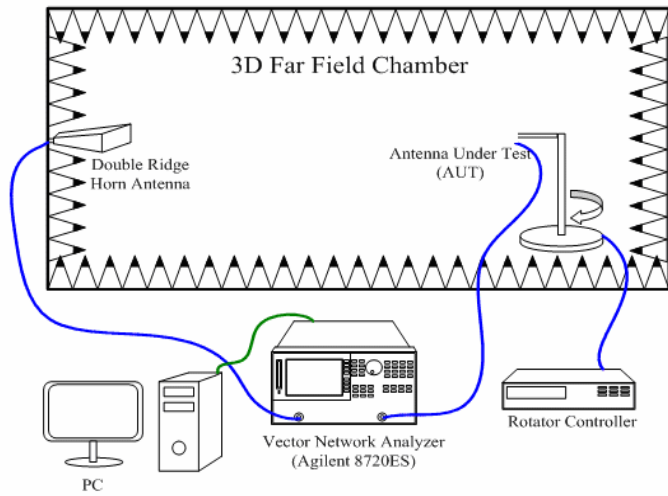
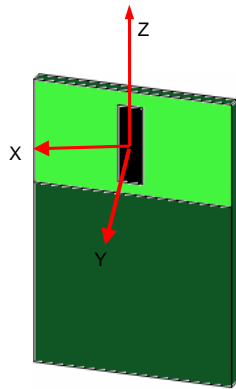

◎3D Gain Pattern(868MHz)

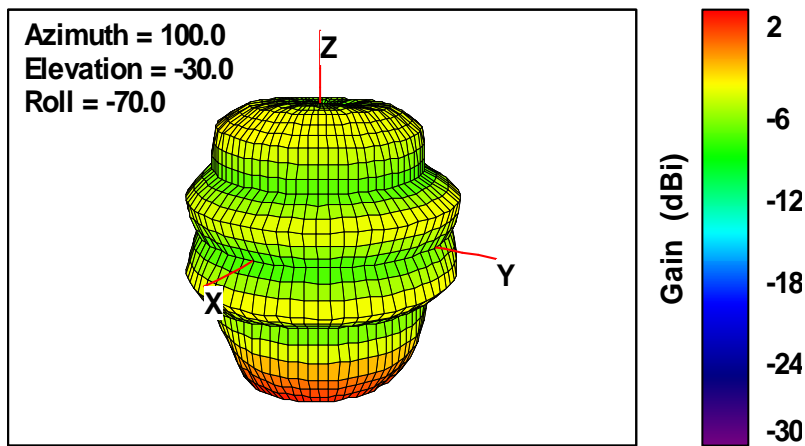

UNLESS OTHER SPECIFIED TOLERANCES ON :

X=± X.X=± X.XX=±
 ANGLES=± HOLEDIA=±



INPAQ TECHNOLOGY CO., LTD.

SCALE : xxxx UNIT : mm

DRAWN BY: 游曉仔 CHECKED BY: 楊奇峯
 DESIGNED BY: 陳威仁 APPROVED BY: 謝立庭

THIS DRAWINGS AND SPECIFICATIONS ARE THE PROPERTY OF INPAQ TECHNOLOGY CO.,LTD.AND SHALL NOT BE REPRODUCED OR USED AS THE BASIS FOR THE MANUFACTURE OR SALE OF APPARATUS OR DEVICES WITHOUT PERMISSION

TITLE : ISM Band Chip Antenna For
 ACG-2505-A1-MF-S

DOCUMENT
 NO.

ENS000036870

SPEC REV.
 P3

7.Environmental Performance

(1) Reliability Test

Item	Condition	Specification
Thermal shock	1. 30±3 minutes at -40°C±3°C, 2. Convert to +85°C (5 minutes) 3. 30±3 minutes at +85°C±3°C, 4. Convert to -40°C (5 minutes) 5. Total 1000 continuous cycles	No apparent damage Fulfill the electrical spec. after test.
Humidity resistance	1. Humidity: 85% R.H. 2. Temperature: 85±2°C 3. Time: 1000 hours.	No apparent damage Fulfill the electrical spec. after test.
High temperature resistance	1. Temperature: 85°C±2°C 2. Time: 1000 hours.	No apparent damage Fulfill the electrical spec. after test.
Low temperature resistance	1. Temperature: -40°C±2°C 2. Time: 1000 hours.	No apparent damage Fulfill the electrical spec. after test.
Soldering heat resistance	1. Solder bath temperature : 260±5°C 2. Bathing time: 10±1 seconds	No apparent damage
Solderability	The dipped surface of the terminal shall be at least 75% covered with solder after dipped in solder bath of 245±5 °C for 3±1 seconds.	No apparent damage

(2) Storage condition

(a) At warehouse:

The temperature should be within 0 ~ 30°C and humidity should be less than 75% RH.

The product should be used within 6 months from the time of delivery.

(b) On board:

The temperature should be within -40~85°C and humidity should be less than 85% RH.

(3) Operating temperature range

Operating temperature range : -40°C to +85°C.

UNLESS OTHER SPECIFIED TOLERANCES ON :

X=±

X.X=±

X.XX=

ANGLES=±

HOLEDIA=±



INPAQ TECHNOLOGY CO., LTD.

SCALE : xxxx

UNIT : mm

DRAWN BY: 游曉仔

CHECKED BY: 楊奇峯

DESIGNED BY: 陳威仁

APPROVED BY: 謝立庭

THIS DRAWINGS AND SPECIFICATIONS ARE THE PROPERTY OF INPAQ TECHNOLOGY CO.,LTD.AND SHALL NOT BE REPRODUCED OR USED AS THE BASIS FOR THE MANUFACTURE OR SALE OF APPARATUS OR DEVICES WITHOUT PERMISSION

TITLE : ISM Band Chip Antenna For
ACG-2505-A1-MF-S

DOCUMENT
NO.

ENS000036870

SPEC REV.

P3

8.Recommendable reflow soldering

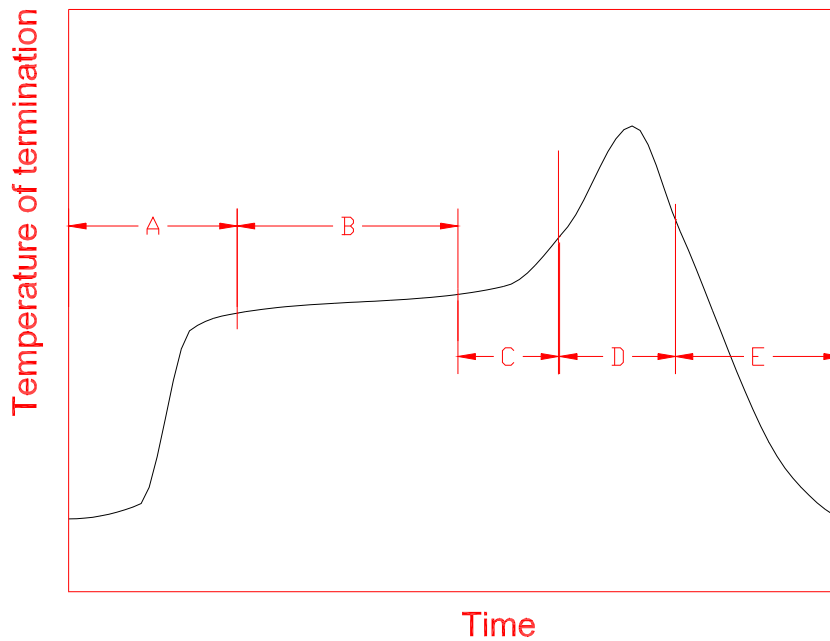

A	1 st rising temperature	The normal to Preheating temperature	30s to 60s
B	Preheating	140°C to 160°C	60s to 120s
C	2 nd rising temperature	Preheating to 200°C	20s to 40s
D	Main heating	if 220°C	50s~60s
		if 230°C	40s~50s
		if 240°C	30s~40s
		if 250°C	20s~40s
		if 260°C	20s~40s
E	Regular cooling	200°C to 100°C	1°C/s ~ 4°C/s

(1) Soldering gun procedure

Note the follows, in case of using solder gun for replacement.

- (a) The tip temperature must be less than 380°C for the period within 3 seconds by using soldering gun under 30 W.
- (b) The soldering gun tip shall not touch this product directly.

(2) Soldering volume

Note that excess of soldering volume will easily get crack the body of this Product.

UNLESS OTHER SPECIFIED TOLERANCES ON :			INPAQ TECHNOLOGY CO., LTD.
X=±	X.X=±		
ANGLES=±		HOLEDIA=±	
SCALE : xxxx	UNIT : mm	THIS DRAWINGS AND SPECIFICATIONS ARE THE PROPERTY OF INPAQ TECHNOLOGY CO.,LTD.AND SHALL NOT BE REPRODUCED OR USED AS THE BASIS FOR THE MANUFACTURE OR SALE OF APPARATUS OR DEVICES WITHOUT PERMISSION	
DRAWN BY: 游曉仔	CHECKED BY: 楊奇峯		
DESIGNED BY: 陳威仁	APPROVED BY: 謝立庭		
TITLE : ISM Band Chip Antenna For ACG-2505-A1-MF-S		DOCUMENT NO.	ENS000036870
			SPEC REV. P3

9. Carry tape

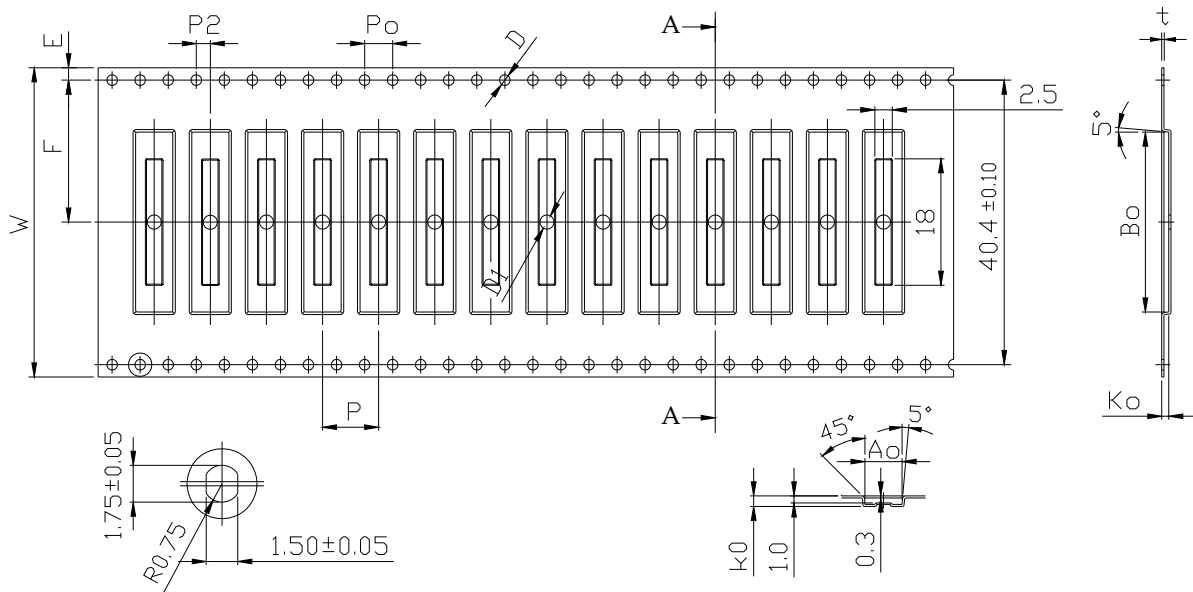

Item	Specifications	tolerance
W	44.00	± 0.30
P	8.00	± 0.10
E	1.75	± 0.10
F	20.20	± 0.10
P2	2.00	± 0.10
D	1.50	+0.10 - 0.00
D1	2.00	± 0.10
Po	4.00	± 0.10
10Po	40.00	± 0.20
Ao	5.40	± 0.10
Bo	20.50	± 0.10
Ko	1.10	± 0.10
t	0.30	± 0.05

- (1) sprocket hole pitch cumulative tolerance ± 0.20 mm.
- (2) Carrier camber not to exceed 1mm in 250mm.
- (3) Ao and Bo measured on a plane 0.3mm above the bottom of the pocket.
- (4) Ko measured from a plane on the inside bottom of the pocket to the top surface of the carrier.

UNLESS OTHER SPECIFIED TOLERANCES ON :

X= \pm

X.X= \pm

X.XX= \pm

ANGLES= \pm

HOLEDIA= \pm



INPAQ TECHNOLOGY CO., LTD.

SCALE : xxxx

UNIT : mm

DRAWN BY: 游曉仔

CHECKED BY: 楊奇峯

DESIGNED BY: 陳威仁

APPROVED BY: 謝立庭

THIS DRAWINGS AND SPECIFICATIONS ARE THE PROPERTY OF INPAQ TECHNOLOGY CO.,LTD.AND SHALL NOT BE REPRODUCED OR USED AS THE BASIS FOR THE MANUFACTURE OR SALE OF APPARATUS OR DEVICES WITHOUT PERMISSION

TITLE : ISM Band Chip Antenna For
ACG-2505-A1-MF-S

DOCUMENT
NO.

ENS000036870

SPEC REV.

P3

- (5) All dimensions meet EIA-481-B requirements
- (6) Material: Clear Non Anti-Static Polystyrene.
 Black Anti-Static Polystyrene.
- (7) Packing length per 13" reel: 32.6Meters.
- (8) Component load per 13" reel : 2000 Pcs

UNLESS OTHER SPECIFIED TOLERANCES ON :			INPAQ TECHNOLOGY CO., LTD.
X=±	X.X=±		
ANGLES=±		HOLEDIA=±	
SCALE : xxxx	UNIT : mm	THIS DRAWINGS AND SPECIFICATIONS ARE THE PROPERTY OF INPAQ TECHNOLOGY CO.,LTD.AND SHALL NOT BE REPRODUCED OR USED AS THE BASIS FOR THE MANUFACTURE OR SALE OF APPARATUS OR DEVICES WITHOUT PERMISSION	
DRAWN BY: 游曉仔	CHECKED BY: 楊奇峯		
DESIGNED BY : 陳威仁	APPROVED BY: 謝立庭		
TITLE : ISM Band Chip Antenna For ACG-2505-A1-MF-S		DOCUMENT NO.	ENS000036870
			SPEC REV. P3