

VECO VANSONIC ENTERPRISE CO.,LTD.

8F., No7, Lane16, Sec2, Szechwan Road, Panchiao, Taipei Hsien, TAIWAN.
 E-mail: Vansonic@ms4.hinet.net Homepage: <http://www.veco.com.tw>
 TEL: +886-2-962 6335 FAX: +886-2-962 5220

1.	MODEL:	3516KMG04HX DYNAMIC SPEAKER
2.	Dimension	Outer Diameter 35*16 mm.
		Height Refer to Fig 1 mm. Weight 4.4 Grams.
3.	Magnet	Materials NdFeB
4.	Impedance	4 Ω ± 15 % At 1500 Hz.
5.	Power Rating	Normal 2.0 W. Maximum 2.5 W.
6.	Lowest Resonant Frequency	520 ± 20% Hz at 1.0V measured by SUNLILAB® 7117C
7.	Output Sound Pressure (S.P.L.)	83 ± 3 db / 1.0Watt · 0.5Meter , Measured by B&K Type 2012
		At 800, 1000, 1200, 1500 HZ Average
8.	Frequency Range	380 ~ 20,000+ Hz. Average SPL -10db Refer to Fig. 2
9.	Distortion	5% Maximum at 1000 Hz 1 W.
10.	Abnormal Sound Test	Must be Normal Tested By 2.83 Volts. Sine Wave.
11.	Load Test	Pink noise with HPF(High Pass Filter 235HZ-3db-11db/Oct) 2.83 Volts(RMS.) 24 hrs.
12.	Storage Temperature	- 25°C ~ + 60°C
13.	Operating Temperature	- 20°C ~ + 60°C

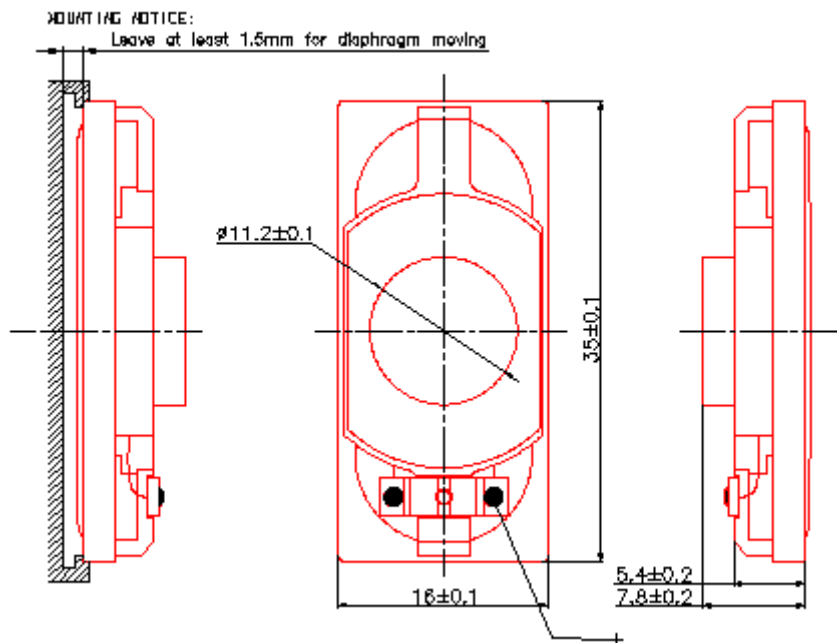
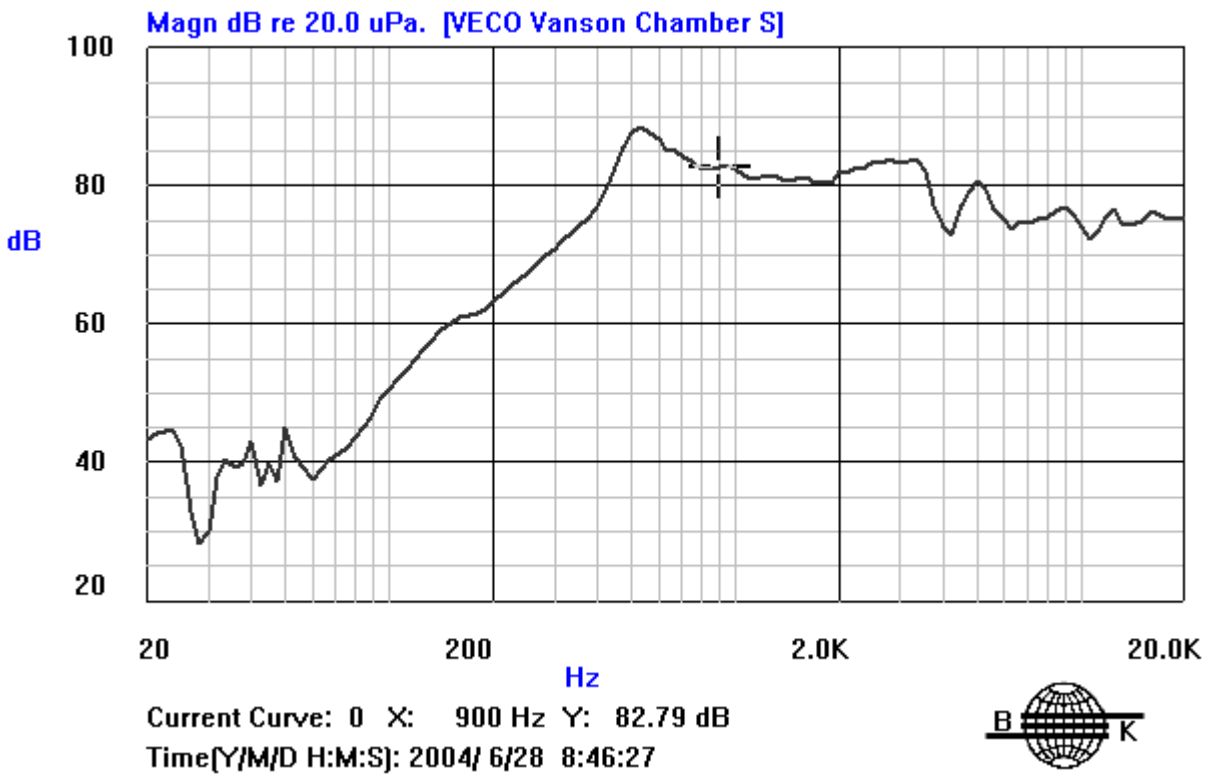

Fig.1

14.Frequency Response Curve.

14.1 Speaker

Sound Pressure Level(SPL) :83± 3dB 1.0W/0.5M at (800,1k,1.2k,1.5k) AV



INPUT: 1.0W
MIC DIST: 0.5M
BAFFLE: IEC6028-5

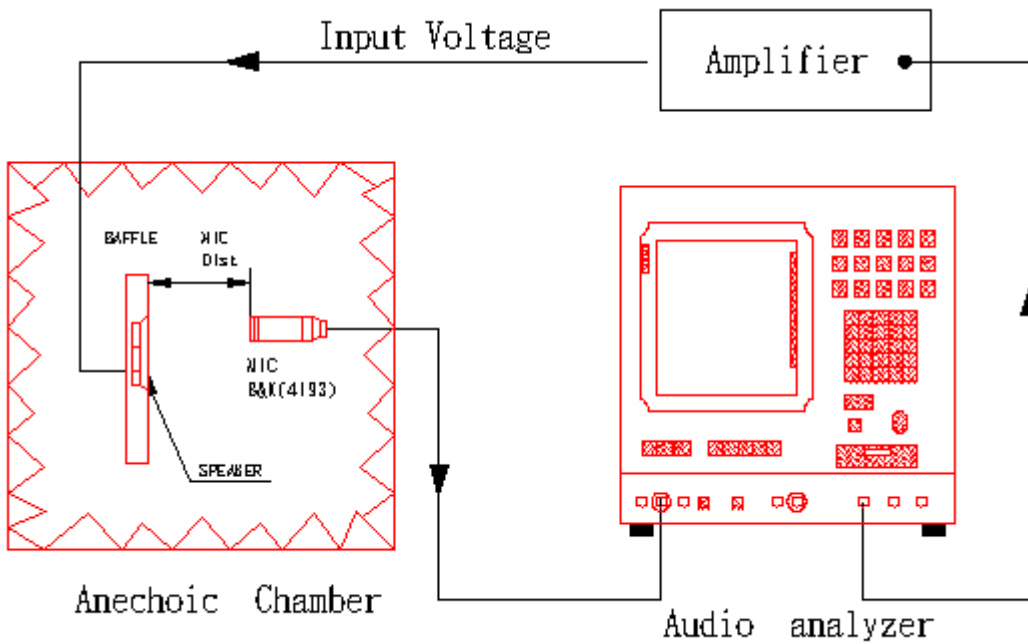

Fig.2

15.Environment Test

15.1 Environment test – High temperature.

After exposure the speaker in the $+ 60 \pm 3$ °C chamber for 24 hours, then leave the speaker at room temperature for 1 hour, the SPL should not deviate by ± 3 db, compare with pre-test measurement.

15.2 Environment test - Low temperature.

After exposure the speaker in the $- 25 \pm 3$ °C chamber for 24 hours, then leave the speaker at room temperature for 1 hour, the SPL should not deviate by ± 3 db, compare with pre-test measurement.

15.3 Environment test-Temperature cycle.

After exposure the speaker in the chamber, temperature cycle setting as below shows, SPL should not Deviate by ± 4 db,compare with pre-test measurement.

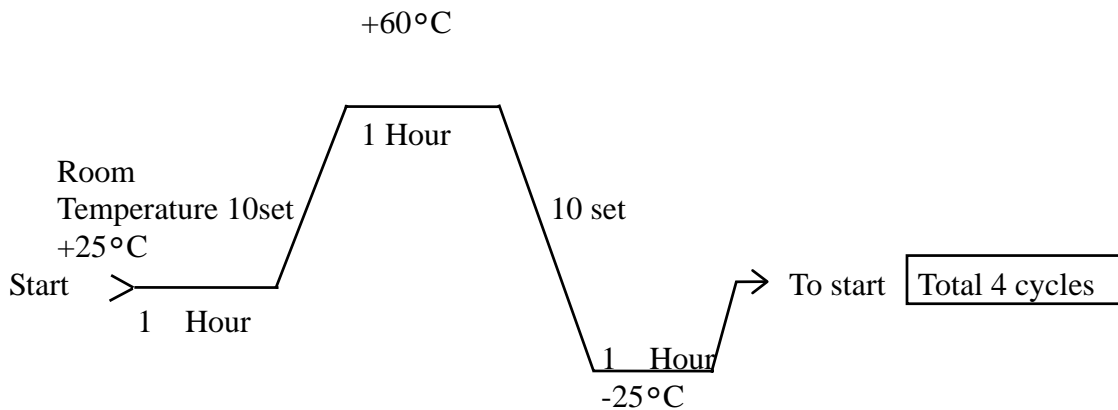

15.4 Environment test – Humidity.

After exposure the speaker in the $+ 40 \pm 3$, relative humidity 90% ~95% chamber for 24 hours, then leave the speaker at room temperature for 6 hours, the SPL should not deviate by ± 3 db, compare with pre-test measurement.