

VECO VANSONIC ENTERPRISE CO., LTD.

8F., No. 7, Lane 16, Sec. 2, Szechwan Road, Panchiao, Taipei Hsien, TAIWAN.

TEL: +866-2-29626335

FAX: +866-2-29625220

E-MAIL: vansonic@ms4.hinet.net

1.	MODEL:	25KE08			
2.	Dimension	Outer Diameter 25X25 mm.			
		Height	Refer to Drawing	Weight	5.0 Grams.
3.	Magnet	Materials	Rare Earth	Size	∅ 11.5X2.0 mm.
4.	Resistance	8	±	15	%
5.	Power Rating	Normal	2.0 W.	Maximum	2.5 W.
6.	Lowest Resonant Frequency	350	±	20	% Hz.
7.	Output Sound Pressure Level (S.P.L.)	80 ± 3 db / 1.0 Watt . 0.5 Meter.			
		Average at	800, 1000, 1200, 1500	Hz.	
8.	Frequency Range	200	~	20000	Hz. Average S P L - 10 db.
9.	Distortion	5	%	Maximum At	1000 Hz. 1.0 W.
10.	Abnormal Sound Test	Must Be Normal Tested By 4.0 Volts. Sine Wave.			
11.	Load Test	Pink Noise With Weighted Filter 4.0 Volts.(RMS) 96 Hrs.			
12.	Polarity	Diaphragm shall move Forward when Apply a Positive DC.			
		Current to the "+" or "Marked" Terminal.			

MOUNTING NOTICE

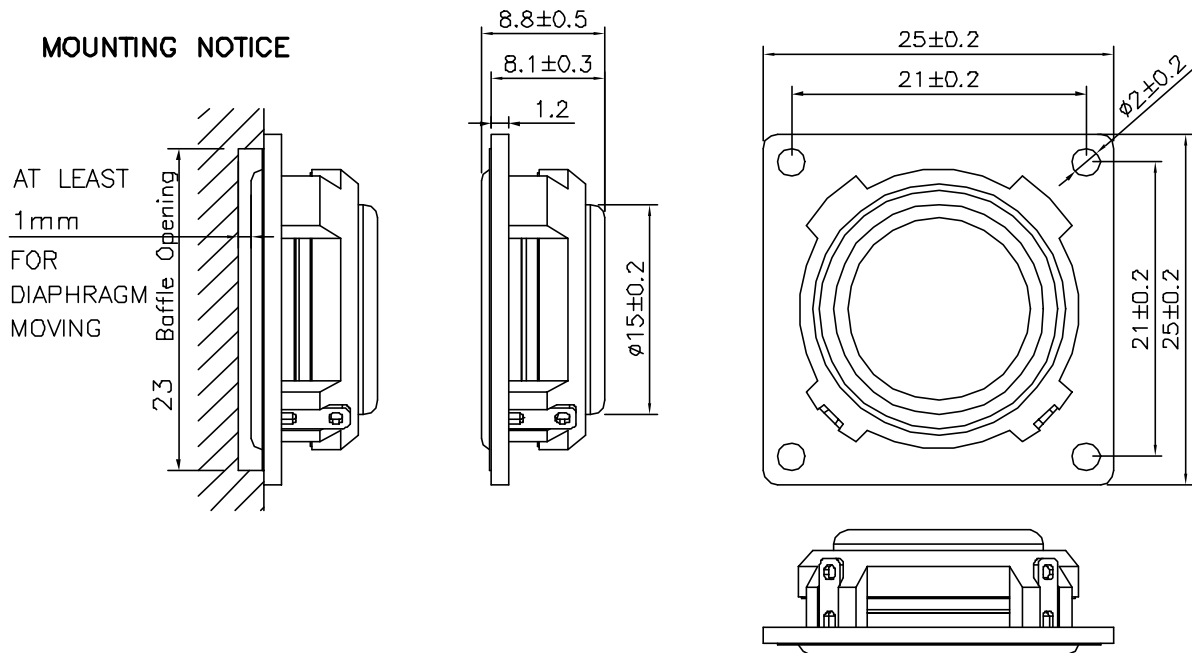

Unit : mm

Housing Material : ABS

P25KE08 VOL:2.828V(1.0W) DIS:0.5M VANSONIC
X:1.0000kHz *Y:80.34dB ZA:1.0000 SSR Fund.

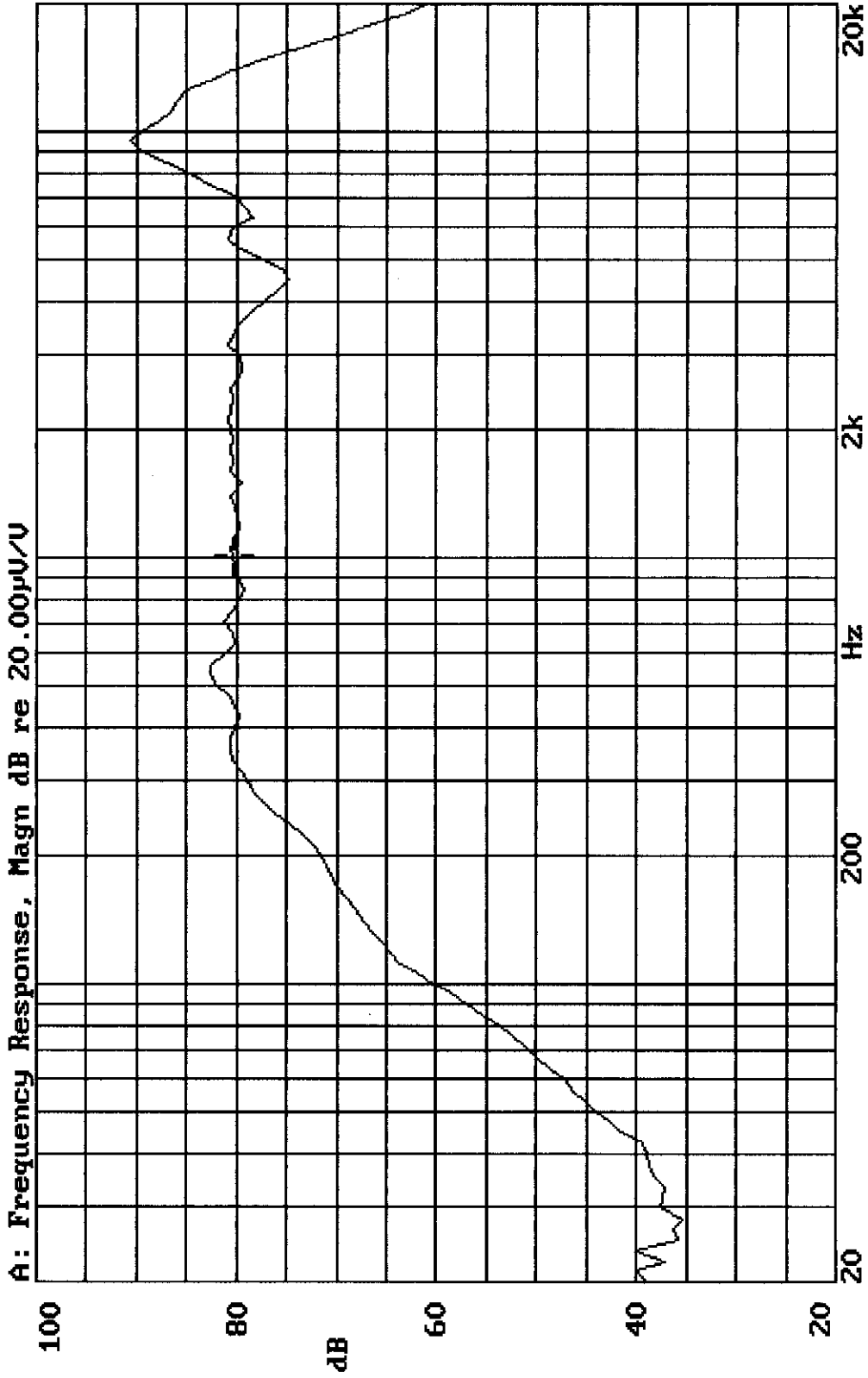

03-DEC-2003 12:44:53

Mode: SSR

