

VECO VANSONIC ENTERPRISE CO., LTD.

8F., No.7, Lane 16, Sec.2, Szechwan Road, Panchiao, Taipei Hsien, TAIWAN.

TEL: +886-2-29626335

FAX: +886-2-29625220

E-MAIL: VANSONIC@MS4.HINET.NET

1.	MODEL:	36CS08G -M50NT(Clear Mylar)			
2.	Dimension	Outer Diameter	36 mm.	Baffle Opening	33 mm.
		Height	Refer to Drawing.	Weight	4.6 Grams.
3.	Magnet	Materials	Rare Earth	Size	∅ 12.5X1.5 mm.
4.	Nominal Impedance	8	± 15 %	At	1500 Hz.
5.	Power Rating	Normal	100 mW.	Maximum	200 mW.
6.	Lowest Resonant Frequency	420	± 20 %		Hz.
7.	Output Sound Pressure Lever (S.P.L.)	76 ± 3 db / 0.1 Watt . 0.5 Meter.			
		Average at	600,	800,	1000, 1200 Hz.
8.	Frequency Range	250	~ 6000 Hz.	Average SPL - 10 db.	
9.	Distortion	5 %	Maximum At	1000 Hz.	100 mW.
10.	Abnormal Sound Test	Must be Normal Tested By		0.9 Volts.	Sine Wave.
11.	Load Test	White Noise with Weighted Filter		0.9 Volts.(RMS)	24Hrs.
12.	Polarity	Diaphragm shall move Forward when Apply a Positive DC.			
		Current to the "+" or "Marked" Terminal.			

MOUNTING NOTICE

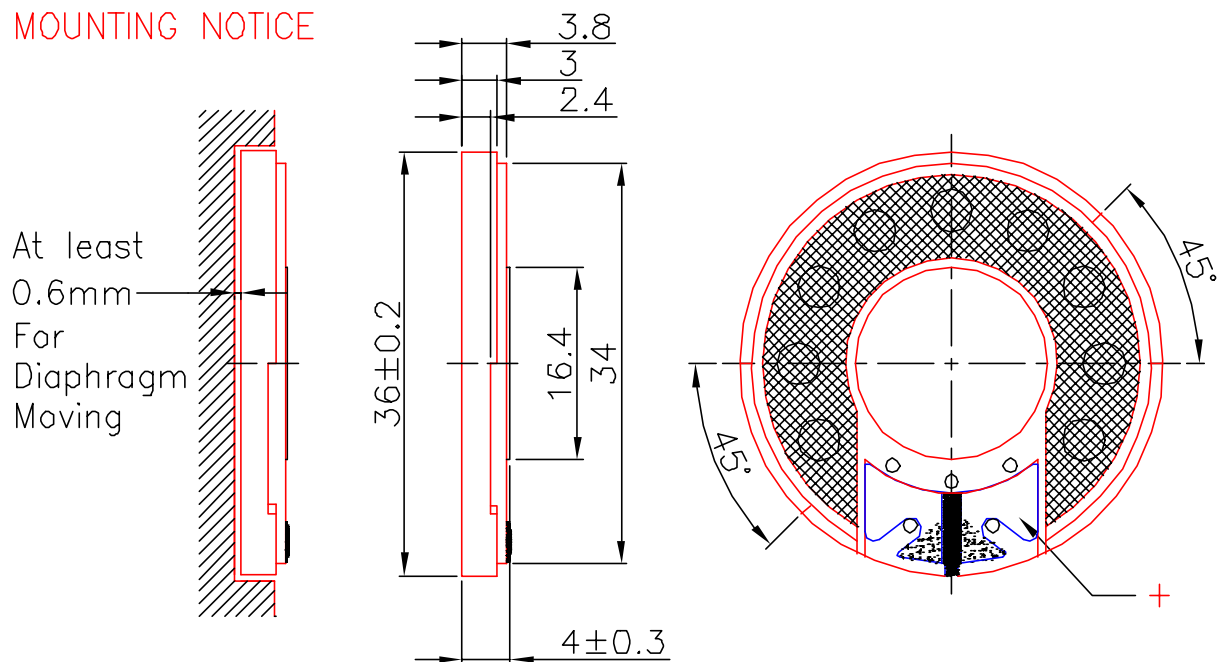

Unit : mm

Housing Material : ABS

36CS08G-50NT Vol:0.894V(0.1W) Dis:0.5M VANSONIC
X:1.0000kHz *Y:74.50dB ZA:Live Curve SSR Fund.

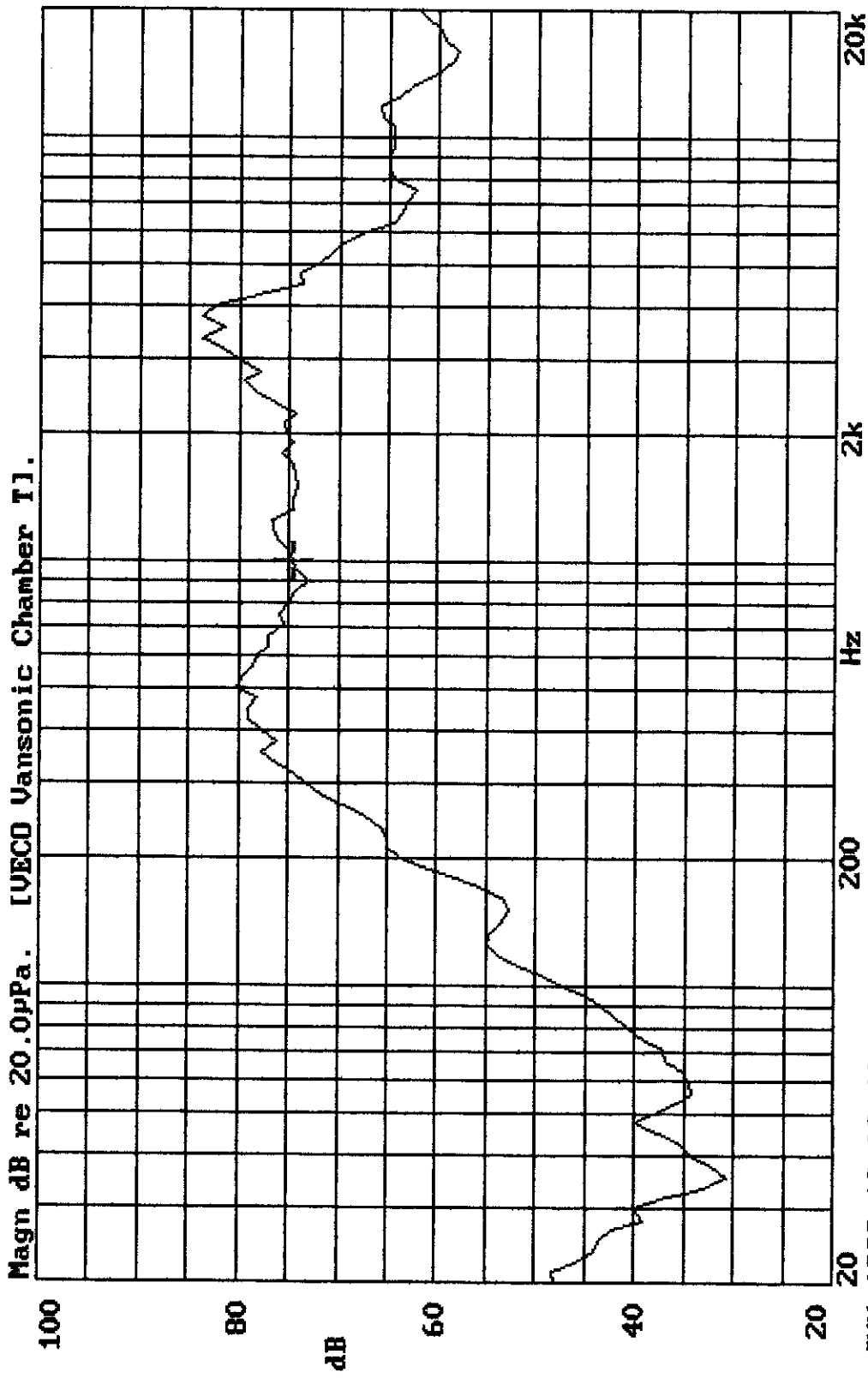

29-JUN-1999 13:03:41

Mode: SSR

