

# VECO VANSONIC ENTERPRISE CO., LTD.

8F., No. 7, Lane 16, Sec. 2, Szechwan Road, Panchiao, Taipei Hsien, TAIWAN.

TEL: +866-2-29626335

FAX: +866-2-29625220

E-MAIL: vansonic@ms4.hinet.net

1.	<b>MODEL:</b>	<b>2010VRG08LQ-E38NT</b>
2.	Dimension	Outer Diameter <b>20X10</b> mm. Baffle Opening <b>18.8X8.8</b> mm.
		Height <b>Refer to Drawing</b> . Weight <b>1.8</b> Grams.
3.	Magnet	Materials <b>Rare Earth</b> . Size <b>∅13.1X ∅8.1X1.5</b> mm.
4.	Resistance	<b>8</b> ± <b>15</b> %
5.	Power Rating	Normal <b>0.5</b> W. Maximum <b>1.0</b> W.
6.	Lowest Resonant Frequency	<b>1300</b> ± <b>20</b> % Hz.
7.	Output Sound Pressure Level (S.P.L.)	<b>88</b> ± <b>3</b> db / 0.5 Watt . 0.1 Meter.
		Average at <b>1000, 1200, 1500, 2000</b> Hz.
8.	Frequency Range	<b>800</b> ~ <b>20000</b> Hz. Average S P L - 10 db.
9.	Distortion	<b>5</b> % Maximum At <b>1000</b> Hz. <b>0.5</b> W.
10.	Abnormal Sound Test	Must Be Normal Tested By <b>2.0</b> Volts. Sine Wave.
11.	Load Test	White Noise With Weighted Filter <b>2.0</b> Volts.(RMS) <b>96</b> Hrs.
12.	Polarity	Diaphragm shall move Forward when Apply a Positive DC.
		Current to the "+" or "Marked" Terminal.

## MOUNTING NOTICE

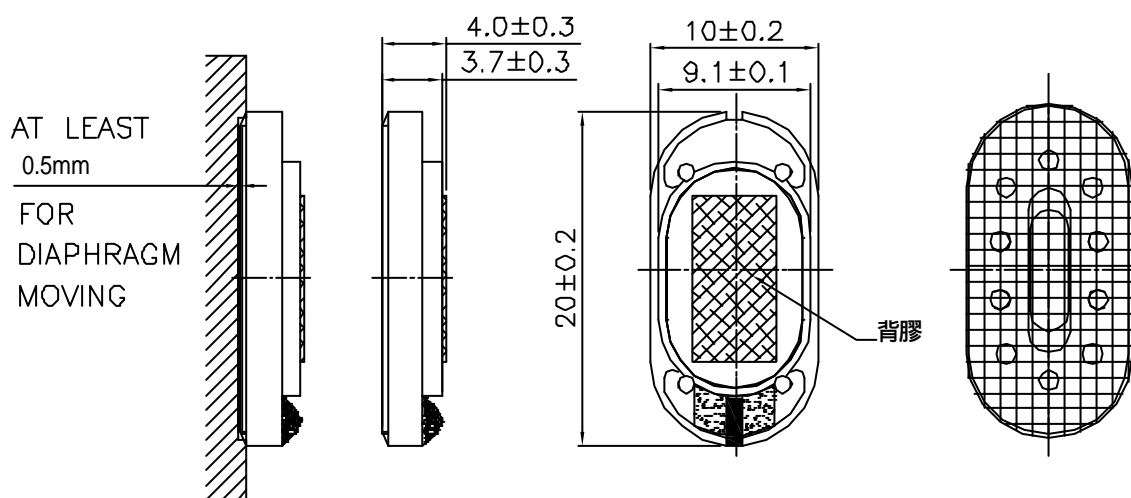

Unit : mm

Housing Material : ABS

P2010URG08LQ-7FH VDL:2.0V(0.5W) DIS:0.1M VANSONIC  
X:1.0000KHZ \*Y:85.23dB ZA:1.0000 SSR Fund.

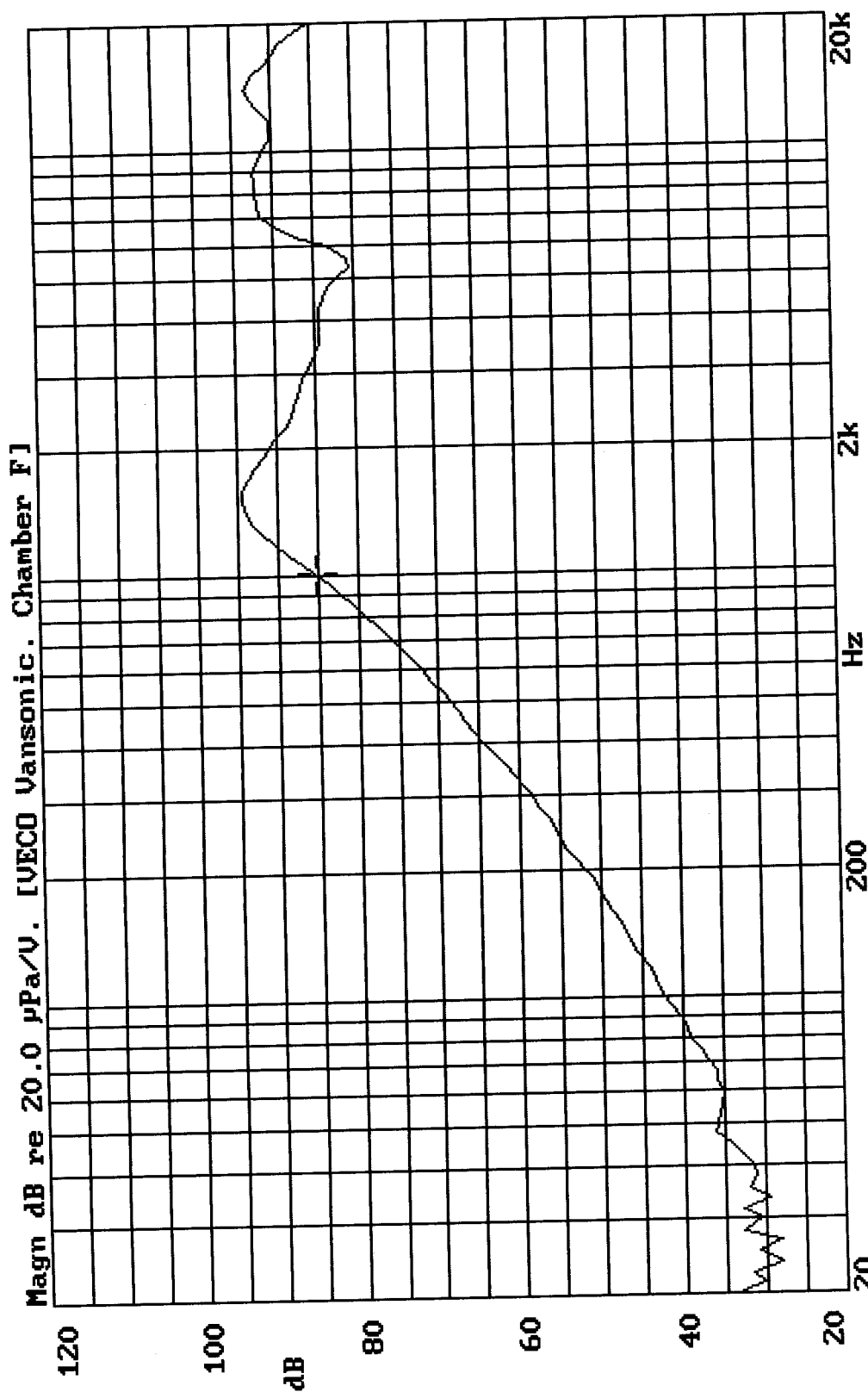

27-MAY-2004 15:29:07

Mode: SSR