

Product name	Description	Version
RTK-1010-SB	Single-frequency multi-constellation GNSS RTK module	0.1



1 Introduction

RTK-1010-SB is a high-performance single-frequency GNSS RTK module that designed for applications requiring centimeter level positioning accuracy. It adopts 12 nm process and integrates efficient power management architecture to perform low power and high sensitivity. The module supports concurrent reception of GPS/QZSS, GLONASS, GALILEO, BEIDOU and NAVIC to improve the availability and reliability of RTK solution even in the harsh environment.

2 Features

- Single-frequency and multi-constellation RTK positioning solution
- Support GPS/QZSS, GLONASS, GALILEO, BEIDOU and NAVIC
- Capable of SBAS (WAAS, EGNOS, MSAS, GAGAN)
- Support 75-channel GNSS
- Low power consumption
- Fast TTFF at low signal level
- Small form factor 10.1 x 9.7 x 2.2 mm
- SMD type with stamp holes; RoHS compliant

3 Application

- Precision Agriculture
- Structural / Land Monitoring
- Offshore / Marine Application

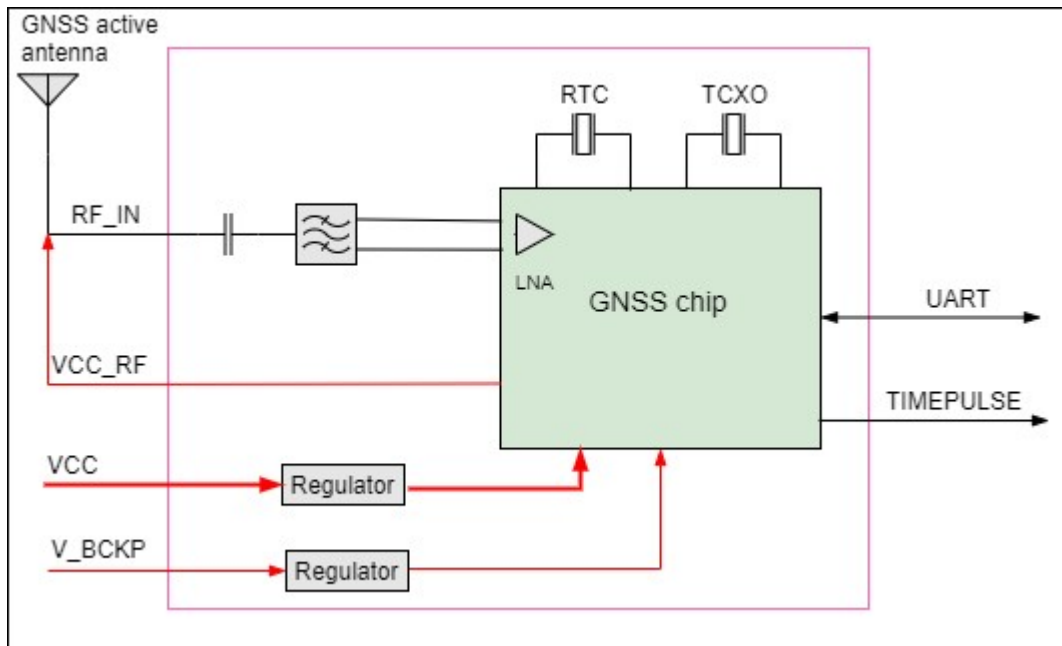

Fig 3-1 System block diagram.

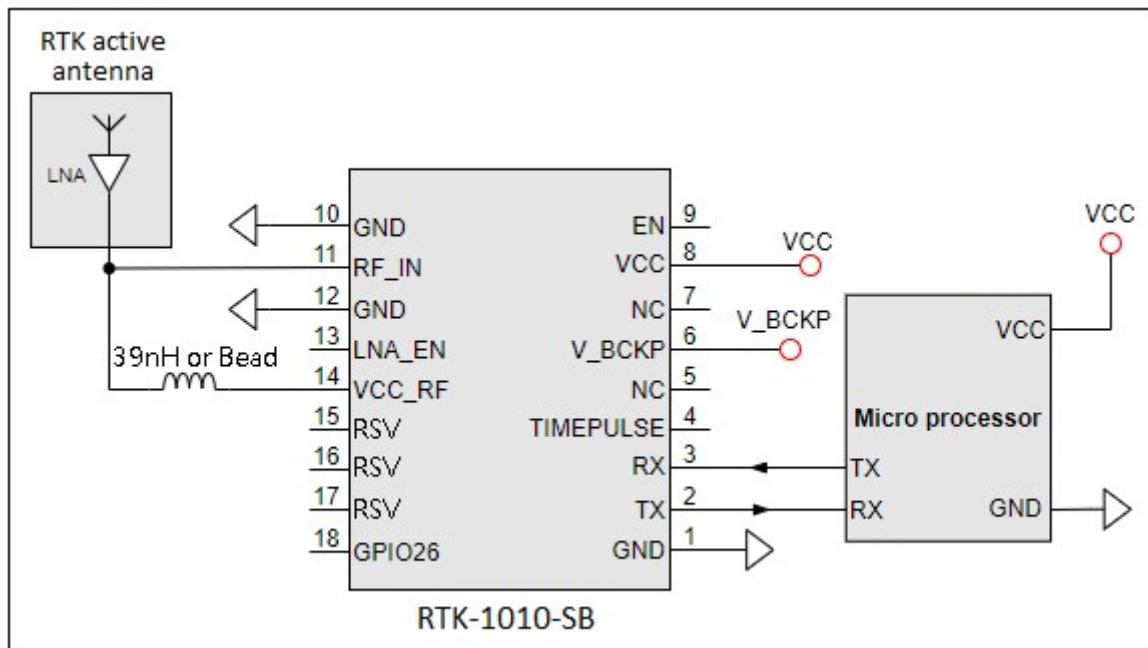

Fig 3-2 Typical application circuit that uses an active antenna.

4 GNSS receiver

Frequency	GPS/QZSS: L1 C/A GLONASS: L1OF GALILEO: E1 BEIDOU: B1I IRNSS (NAVIC): L5	
Channels	Support 75 channels	
Update rate	1Hz, 5Hz	
Sensitivity	Tracking	-165dBm (with external LNA)
	Cold start	-148dBm (with external LNA)
Acquisition Time	Cold start	28s (typical)
	RTK convergence time	< 10s (typical, after 3D fix)
Position Accuracy ⁽¹⁾	Autonomous	2.5m CEP
	RTK	0.01m + 1ppm CEP (Horizontal)
Max. Altitude	< 18,000 m	
Max. Velocity	< 500 m/s	
Protocol Support	NMEA 0183 ver. 4.1	115200 bps ⁽²⁾ , 8 data bits, no parity, 1 stop bits (default) 1Hz: GGA, GLL, GSA, RMC, VTG 0.2Hz: GSV
	Raw data	RTCM3.3 Message type 1005, 1074, 1084, 1094, 1114, 1124

Note 1: Open sky, demonstrated with a good antenna.

Note 2: Both baud rate and output message rate are configurable to be factory default.

5 Software interface

5.1 NMEA output message

Table 5.1-1 NMEA output message

NMEA record	Description
GGA	Global positioning system fixed data
GLL	Geographic position - latitude/longitude
GSA	GNSS DOP and active satellites
GSV	GNSS satellites in view
RMC	Recommended minimum specific GNSS data
VTG	Course over ground and ground speed

● GGA--- Global Positioning System Fixed Data

Table 5.1-2 contains the values for the following example:

\$GNGGA,091250.000,2503.71250,N,12138.74514,E,1,32,0.55,119.0,M,17.2,M,,*7E

Table 5.1-2 GGA Data Format

Name	Example	Units	Description
Message ID	\$GNGGA		GGA protocol header
UTC Time	091250.000		hhmmss.sss
Latitude	2503.71250		ddmm.mmmmm
N/S indicator	N		N=north or S=south
Longitude	12138.74514		dddmm.mmmmm
E/W Indicator	E		E=east or W=west
Position Fix Indicator	1		See Table 5.1-3
Satellites Used	32		Number of satellites in view
HDOP	0.55		Horizontal Dilution of Precision (meters)
MSL Altitude	119.0	meters	Antenna Altitude above/below mean-sea-level (geoid) (in meters)
Units	M	meters	Units of antenna altitude, meters
Geoidal Separation	17.2	meters	
Units	M	meters	Units of geoidal separation, meters
Age of diff. GNSS data		second	Null fields when DGPS is not used
Diff. Ref. Station ID			Differential reference station ID, 0000-1023
Checksum	*7E		Checksum
<CR> <LF>			End of message termination

Table 5.1-3 Position Fix Indicators

Value	Description
-------	-------------

0	No position fix
1	Autonomous GNSS fix
2	Differential GNSS fix
4	RTK fixed
5	RTK float
6	Estimated/Dead reckoning fix

● **GLL--- Geographic Position – Latitude/Longitude**

Table 5.1-4 contains the values for the following example:

\$GNGLL,2503.71193,N,12138.74582,E,094450.000,A,A*47

Table 5.1-4 GLL Data Format

Name	Example	Units	Description
Message ID	\$GNGLL		GLL protocol header
Latitude	2503.71193		ddmm.mmmmm
N/S indicator	N		N=north or S=south
Longitude	12138.74582		dddmm.mmmmm
E/W indicator	E		E=east or W=west
UTC Time	094450.000		hhmmss.sss
Status	A		A=data valid or V=data not valid
Mode	A		N = No position fix A = Autonomous GNSS fix D = Differential GNSS fix R = RTK fixed F = RTK float E = Estimated/Dead reckoning fix
Checksum	*47		
<CR> <LF>			End of message termination

● **GSA---GNSS DOP and Active Satellites**

Table 5.1-5 contains the values for the following example:

\$GNGSA,A,3,11,195,194,199,08,07,01,27,16,09,23,,1.19,0.64,1.00,1*3F

\$GNGSA,A,3,87,81,76,,,,,,,,,1.19,0.64,1.00,2*0F

\$GNGSA,A,3,,,,,,,,,1.19,0.64,1.00,3*09

\$GNGSA,A,3,34,24,12,07,11,10,08,38,25,09,13,16,1.19,0.64,1.00,4*02

Table 5.1-5 GSA Data Format

Name	Example	Units	Description
Message ID	\$GNGSA		GSA protocol header

Mode 1	A		See Table 5.1-6
Mode 2	3		See Table 5.1-7
ID of satellite used	11		SV on Channel 1
ID of satellite used	195		SV on Channel 2
....		
ID of satellite used			SV on Channel 12
PDOP	1.19		Position Dilution of Precision
HDOP	0.64		Horizontal Dilution of Precision
VDOP	1.00		Vertical Dilution of Precision
GNSS system ID	4		See Table 5.1-8
Checksum	*3F		
<CR> <LF>			End of message termination

Table 5.1-6 Mode 1

Value	Description
M	Manually set to operate in 2D or 3D mode
A	Automatically switching between 2D or 3D mode

Table 5.1-7 Mode 2

Value	Description
1	No position fix
2	2D fix
3	3D fix

Table 5.1-8 GNSS system ID

Value	Description
1	GPS
2	GLONASS
3	GALILEO
4	BEIDOU
6	IRNSS

● GSV---GNSS Satellites in View

Table 5.1-9 contains the values for the following example:

```
$GPGSV,3,1,09,8,71,268,47,27,63,18,49,11,44,191,46,4,41,237,46,1*54
$GPGSV,3,2,09,16,38,42,42,9,32,279,39,26,22,70,38,31,15,131,36,1*56
$GPGSV,3,3,09,7,15,320,40,1*6B
$GLGSV,2,1,05,82,63,47,47,83,56,182,36,80,47,9,42,79,33,85,45,1*71
$GLGSV,2,2,05,81,15,27,37,1*71
$GAGSV,1,1,04,08,48,300,43,03,47,025,45,13,36,309,42,05,06,061,34,7*79
```

```
$GBGSV,5,1,17,12,80,182,47,24,64,5,51,7,58,355,44,3,57,205,45,1*7C
$GBGSV,5,2,17,1,54,141,44,34,52,211,49,9,48,230,45,10,47,316,42,1*79
$GBGSV,5,3,17,26,44,100,47,16,39,207,43,4,38,117,41,2,37,240,41,1*77
$GBGSV,5,4,17,39,37,210,43,6,36,198,41,38,27,173,41,25,18,317,42,1*4E
$GBGSV,5,5,17,35,16,39,40,1*7F
$GIGSV,2,1,05,05,,,49,04,,,44,09,,,40,07,,,47,1*7E
$GIGSV,2,2,05,03,,,43,1*7C
```

Table 5.1-9 GSV Data Format

Name	Example	Units	Description
Message ID	\$GPGSV		GSV protocol header GP=GPS/QZSS, GL=GLONSS, GA=GALILEO, GB=BEIDOU, GI=IRNSS.
Total number of messages	3		Range 1 to 9
Message number	1		Range 1 to 9
Satellites in view	09		
Satellite ID	8		Channel 1
Elevation	71	degrees	Channel 1 (Range 00 to 90)
Azimuth	268	degrees	Channel 1 (Range 000 to 359)
SNR (C/No)	47	dB-Hz	Channel 1 (Range 00 to 99, null when not tracking)
....		
Satellite ID	4		Channel 4 (Range 01 to 196)
Elevation	41	degrees	Channel 4 (Range 00 to 90)
Azimuth	237	degrees	Channel 4 (Range 000 to 359)
SNR (C/No)	46	dB-Hz	Channel 4 (Range 00 to 99, null when not tracking)
Signal ID	1		GPS/QZSS: L1 C/A=1 GLONASS: L1 C/A=1 GALILEO: E1=7 BEIDOU: B1=1 IRNSS: L5=1
Checksum	*54		
<CR> <LF>			End of message termination

● **RMC---Recommended Minimum Specific GNSS Data**

Table 5.1-10 contains the values for the following example:

```
$GNRMC,070143.000,A,2503.71317,N,12138.74533,E,0.002,70.50,130220,,,A,V*01
```

Table 5.1-10 RMC Data Format

Name	Example	Units	Description
------	---------	-------	-------------

Message ID	\$GNRMC		RMC protocol header
UTC Time	070143.000		hhmmss.sss
Status	A		A=Autonomous GNSS fix D=Differential GNSS fix V=data not valid
Latitude	2503.7117		ddmm.mmmm
N/S Indicator	N		N=north or S=south
Longitude	12138.74533		dddmm.mmmmm
E/W Indicator	E		E=east or W=west
Speed over ground	0.002	knots	True
Course over ground	70.50	degrees	
Date	130220		ddmmyy
Magnetic variation		degrees	
Variation sense			E=east or W=west
Mode	A		N = No position fix A = Autonomous GNSS fix D = Differential GNSS fix R = RTK fixed F = RTK float E = Estimated/Dead reckoning fix
Navigational status indicator	V		S = Safe C = Caution U = Unsafe V = Void
Checksum	*01		
<CR> <LF>			End of message termination

● **VTG---Course Over Ground and Ground Speed**

Table 5.1-11 contains the values for the following example:

\$GNVTG,0.00,T,,M,0.003,N,0.006,K,A*26

Table 5.1-11 VTG Data Format

Name	Example	Units	Description
Message ID	\$GPVTG		VTG protocol header
Course over ground	0.00	degrees	Measured heading
Reference	T		True
Course over ground		degrees	Measured heading
Reference	M		Magnetic

Speed over ground	0.003	knots	Measured speed
Units	N		Knots
Speed over ground	0.006	km/hr	Measured speed
Units	K		Kilometer per hour
Mode	A		N = No position fix A = Autonomous GNSS fix D = Differential GNSS fix R = RTK fixed F = RTK float E = Estimated/Dead reckoning fix
Checksum	*26		
<CR> <LF>			End of message termination

5.2 Proprietary commands

5.2.1 Query firmware version

Synopsis:

```
$PLSC,VER*CK<CR><LF>
```

Response:

```
$PLSR,<VER>*CK<CR><LF>
```

Examples:

```
$PLSC,VER*61<CR><LF>
```

5.2.2 Set up module as a reference station or as a rover

```
$PLSC,MCBASE,<MODE>*CK<CR><LF>
```

Response:

```
$PLSR,MCBASE,<MODE>*CK<CR><LF>
```

Parameter	Format	Description
MODE	Decimal	0: set up the board as a rover(default) 1: set up the board as a reference station (Output RTCM3.3 1005, 1074, 1084, 1094, 1124 messages)

Examples:

```
$PLSC,MCBASE,1*26<CR><LF>
```

5.2.3 Set the base location (reference position)

Synopsis:

```
$PLSC,SETBASEXYZ,<X>,<Y>,<Z>*CK<CR><LF>
```

Response:

```
$PLSR,BASEXYZ,<X>,<Y>,<Z>*CK<CR><LF>
```

Parameter	Format	Description
X	DDDDDDD.DDD	WGS-84 ECEF X-axis coordinate (in meters)
Y	DDDDDDD.DDD	WGS-84 ECEF Y-axis coordinate (in meters)
Z	DDDDDDD.DDD	WGS-84 ECEF Z-axis coordinate (in meters)

Examples:

```
$PLSC,SETBASEXYZ,-3028442.081,4923062.884,2687870.875*03<CR><LF>
```

5.2.4 Set up the output data update rate, in Hz.(included 1, 5)

Synopsis:

```
$PLSC, FIXRATE,<FIXRATE>*CK<CR><LF>
```

Response:

```
$PLSR, FIXRATE,<FIXRATE>*CK<CR><LF>
```

Parameter	Format	Description
FIXRATE	Decimal	1: set up the fix rate as 1Hz (default) 5: set up the fix rate as 5Hz

Examples:

```
$PLSC,FIXRATE,5*6C <CR><LF>
```

5.2.5 Set up the GST message output

Synopsis:

```
$PAIR062,8,<OUTPUT_MODE>*CS<CR><LF>  
$PAIR513*CS<CR><LF>
```

Parameter	Format	Description
OUTPUT_MODE	Decimal	0: disable \$GNGST output (default) 1: enable \$GNGST output

Examples:

```
$PAIR062,8,1*37 <CR><LF>
```

Note: Changing fix rate from 1Hz to 5Hz will reset configuration to factory default settings.

5.2.6 Set up the PLSV message output

Synopsis:

```
$PAIR100, 1,<OUTPUT_MODE>*CS<CR><LF>
```

```
$PAIR513*CS<CR><LF>
```

Parameter	Format	Description
OUTPUT_MODE	Decimal	0: disable \$PLSV output (default) 1: enable \$PLSV output

Examples:

```
$PAIR100,1,1*3B <CR><LF>
```

Note: Changing fix rate from 1Hz to 5Hz will reset configuration to factory default settings

6 Pin assignment and descriptions



Table 6-1 Pin descriptions

Pin #	Name	Type	Description	Note
1	GND	P	Ground	
2	TX	O	Serial output	
3	RX	I	Serial input	
4	TIMEPULSE	O	Time pulse (PPS, default 100 ms pulse/sec when GNSS fix is available)	
5	NC		Not connect	
6	V_BCKP	P	Backup battery input. It is recommended to connect a backup supply voltage to V_BCKP in order to enable warm and hot start features. Moreover, V_BCKP is a must of the system running. If no backup power is available, connect V_BCKP to the main power supply (VCC).	
7	NC		Not connect	
8	VCC	P	DC supply input. Must be clean and stable.	
9	EN	I	Enable the module, high active. Internal 1M ohm pull-up resistor to 1.8V. Setting this pin to low will disable “hot start” function, i.e., boot from “cold start”. Leave unconnected if not used.	
10	GND	P	Ground	
11	RF_IN	I	GNSS RF signal input The overall gain of the active antenna must be between 8dB	

			~ 20dB.	
12	GND	P	Ground	
13	LNA_EN	O	Output pin to control the external LNA. High active.	
14	VCC_RF	O	Output voltage for the active antenna	1
15	RESERVED	I	Leave this pin floating	
16	RESERVED	I/O	Leave this pin floating	
17	RESERVED	I/O	Leave this pin floating	
18	GPIO26	I/O	General purpose I/O	

<Note>

1. VCC_RF is controlled by EN pin (pin 9).

7 DC & Temperature characteristics

7.1 Absolute maximum ratings

Parameter	Symbol	Ratings	Units
DC Supply Input Voltage	VCCabs	5.5	V
Input Backup Battery Voltage	V_BCKPabs	5.5	V
Operating Temperature Range	Topr_abs	-40 ~ 85	°C
Storage Temperature Range	Tstg_abs	-40 ~ 85	°C

7.2 DC Electrical characteristics

Parameter	Symbol	Conditions	Min.	Typ.	Max.	Units
DC Supply Input Voltage	VCC		3.1	3.3	4.5	V
Input Backup Battery Voltage	V_BCKP		2.0		4.5	V
VCC_RF Output Voltage	VCC_RF		2.7	2.85	2.9	V
Supply Current*	Iss	VCC = 3.3V, w/o active antenna, Peak Tracking		45 ⁽²⁾	70 ⁽¹⁾	mA
						mA
	Ishdn	VCC=3.3V, EN=0V		23		uA
Backup Battery Current	Ibat	VIN = 0V		44		uA
VCC_RF Output Current	Iout	VIN = 3.3V			30	mA
High Level Input Voltage	V _{IH}	For TX, RX	2.2		3.6	V
Low Level Input Voltage	V _{IL}		-0.3		0.8	V
High Level Output Voltage	V _{OH}		2.18		3.3	V
Low Level Output Voltage	V _{OL}				0.4	V
High Level Input Voltage	V _{IH}	For TIMEPULSE, EN, LNA_EN, GPIO26	1.21		1.98	V
Low Level Input Voltage	V _{IL}		-0.3		0.6	V
High Level Output Voltage	V _{OH}		1.29		1.98	V
Low Level Output Voltage	V _{OL}				0.45	V

<Note>

1. Measured with 1MHz sampling rate.
2. Measured when RTK fix (1Hz) is available and input voltage is 3.3V.

7.3 Temperature characteristics

Parameter	Symbol	Min.	Typ.	Max.	Units
Operating Temperature	Topr	-40	-	85	°C
Storage Temperature	Tstg	-40	25	85	°C

8 Mechanical specification

8.1 Outline dimensions

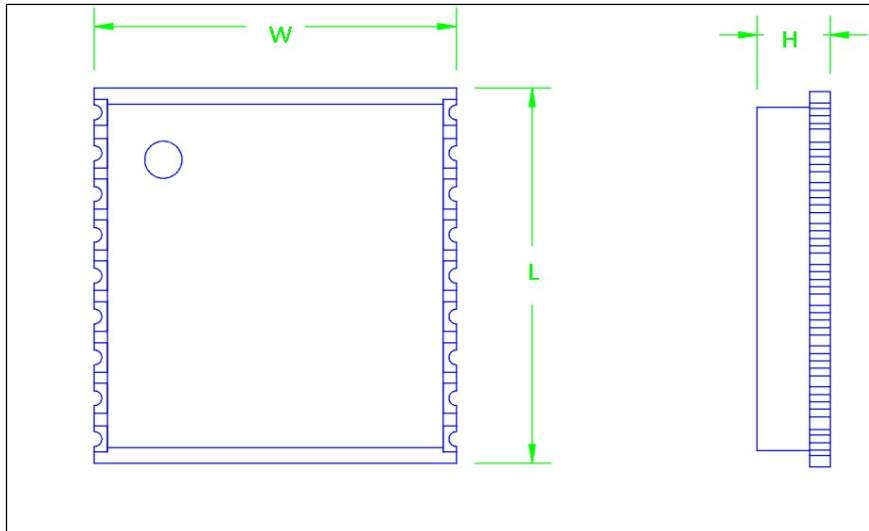

Symbol	Min. (mm)	Typ. (mm)	Max. (mm)
W	9.6	9.7	9.8
L	9.8	10.1	10.4
H	2.0	2.2	2.4

8.2 Recommended land pattern dimensions

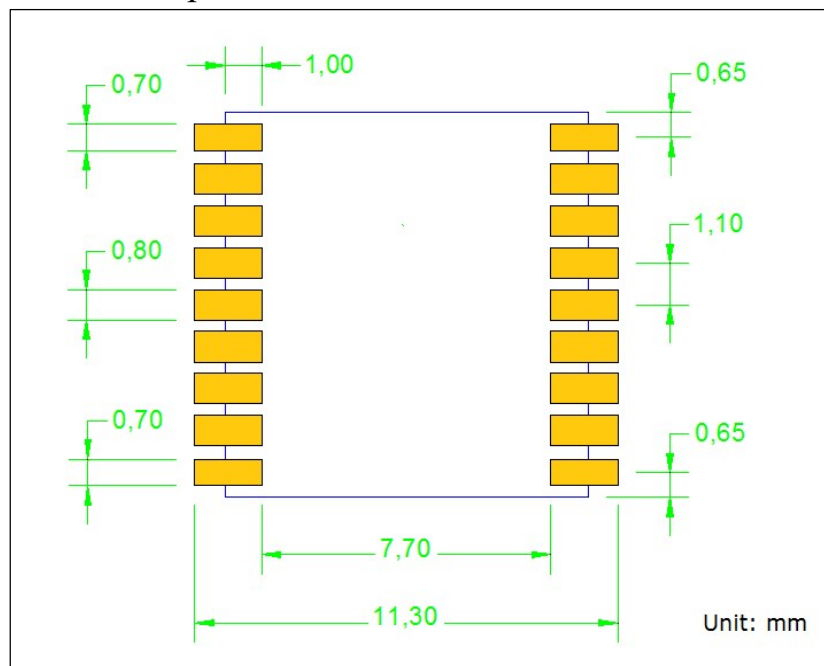

Note: The recommended land pattern dimensions are shown for reference only, as actual pad layouts may vary depending on application.

9 Reel Packing information

9.1 ESD precaution

GNSS modules are electrostatic sensitive devices. Handling the modules without proper ESD protection may result in severe damage to them. ESD protection must be implemented throughout the processing, handling and even when the modules are being returned for repair.

9.2 Packaging

The modules are sealed in a moisture barrier ESD bag with the appropriate units of desiccant and a humidity indicator card. It should not be opened until the modules are ready to be soldered onto the application.

9.2.1 Packaging

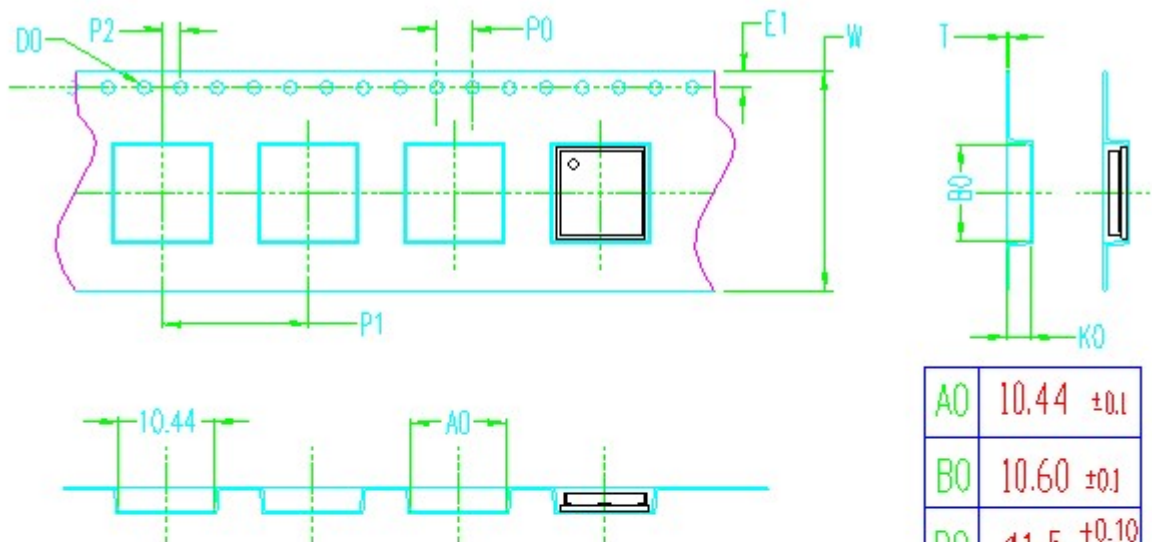

1. 10 sprocket hole pitch cumulative tolerance ±0.2
2. Camber not to exceed 1mm in 250mm
3. A0 and B0 measured on a plane 0.30mm above the bottom of the pocket
4. K0 measured from a plane on the inside bottom of the pocket to the top surface of the carrier
5. pocket position relative to sprocket hole measured as true position of pocket, not pocket hole.
6. Component load per 13" reel: 1500 pcs
7. All dimensions meet EIA-481-C requirements.

9.2.2 Box packaging

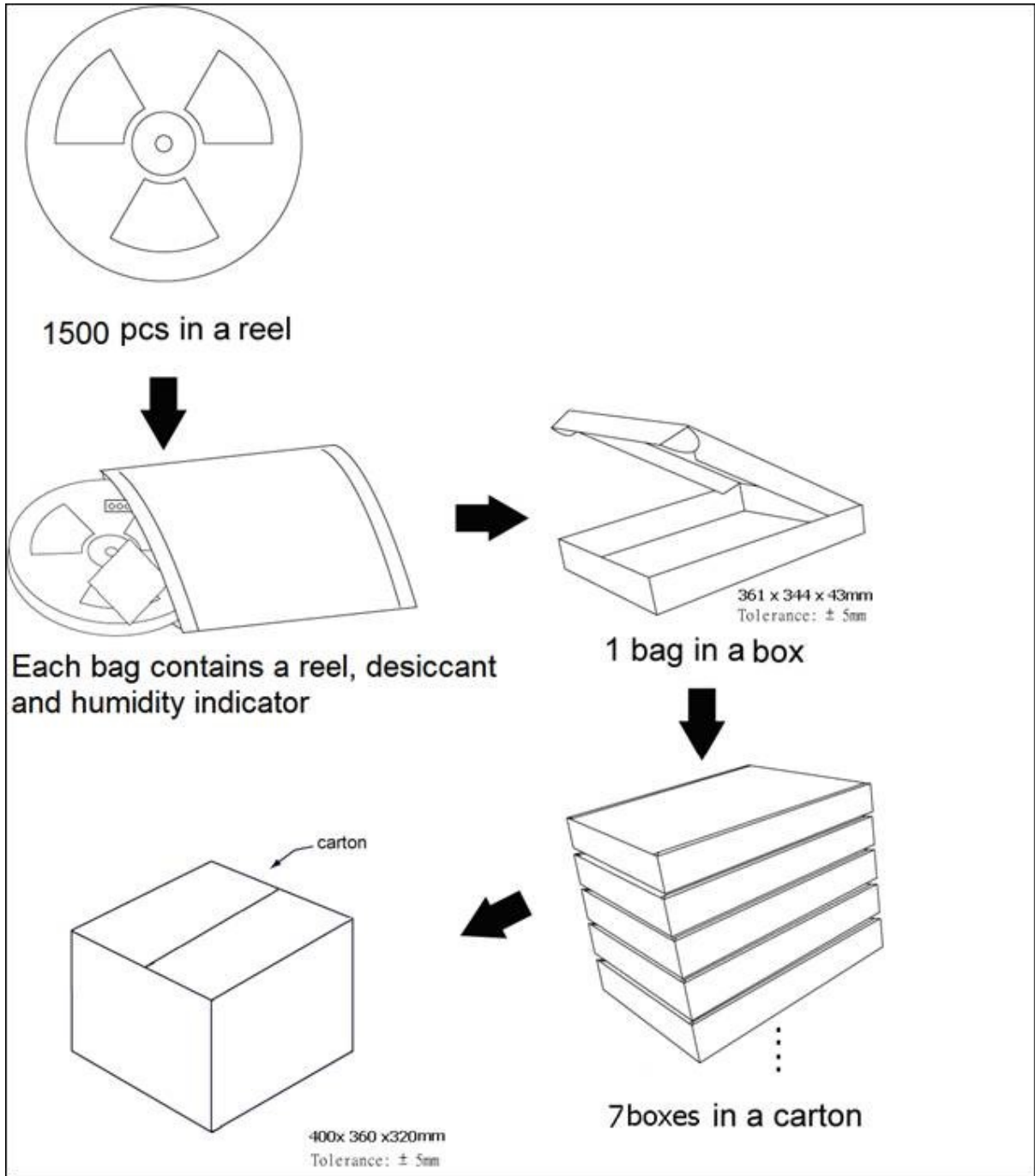

9.3 Moisture sensitivity level

The moisture sensitivity level of the module is 3. After the sealed bag is opened, modules should be mounted within 168 hours at factory conditions of $\leq 30^{\circ}\text{C}$ and 60% RH or stored at $\leq 20\%$ RH.

The modules require baking before mounting if above conditions are not met. If baking is required, the modules without the tape and reel may be baked for:

- a. 192 hours at $40^{\circ}\text{C} + 5^{\circ}\text{C} / -0^{\circ}\text{C}$ and $< 5\%$ RH
- b. 24 hours at $125^{\circ}\text{C} + 5^{\circ}\text{C} / -0^{\circ}\text{C}$

9.4 Reflow soldering

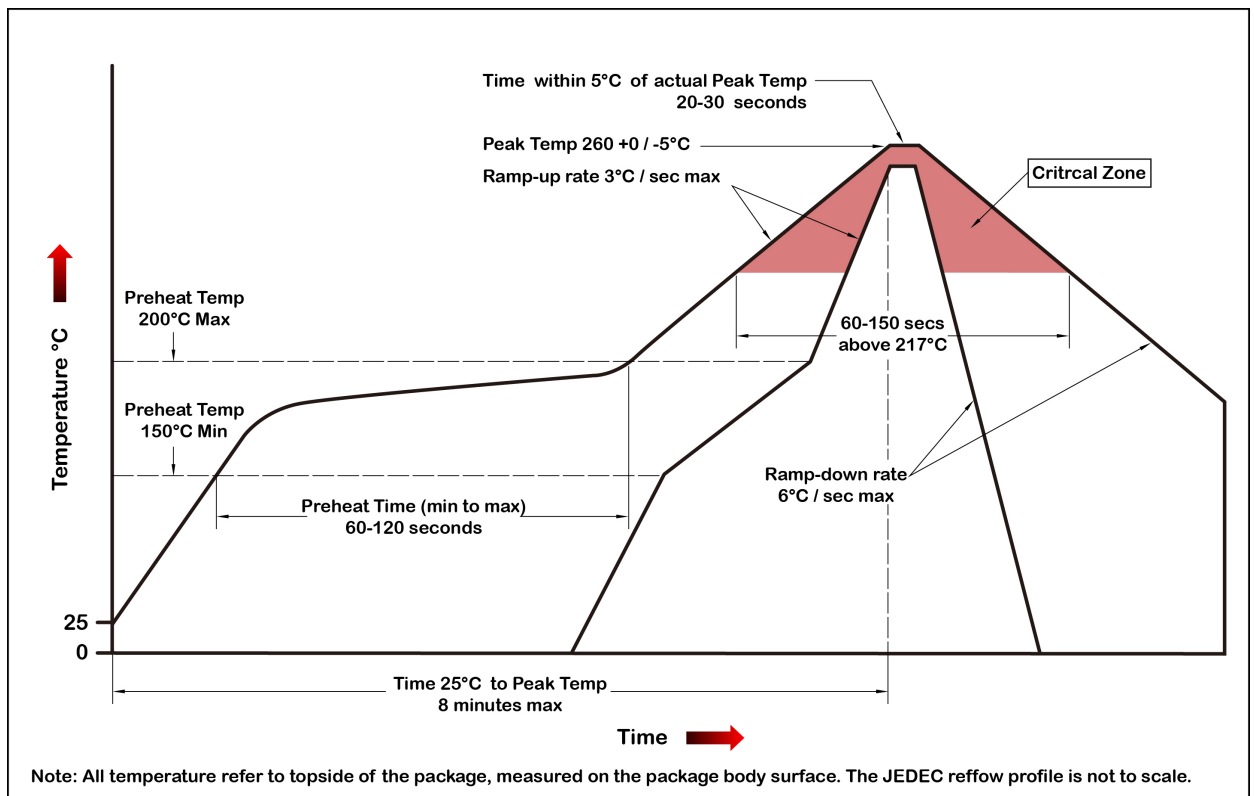

Note the module mounted to the top side (first reflow side) may fall off during reflow soldering of the bottom side.

10 Product marking and ordering information

10.1 Product marking

The marking of the module is engraved on the metal shielding that has product information, such as LOCOSYS logo, product name and manufacturing date.

10.2 Ordering information

Product name	Description	Remark
RTK-1010-SB	Single-frequency multi-constellation GNSS RTK module	GPS/QZSS: L1 C/A GLONASS: L1OF GALILEO: E1 BEIDOU: B1I IRNSS (NAVIC): L5

Document change list

Revision 0.1

- Draft release on July 7, 2021.