

CONFIDENTIAL

VERTRAULICH

THIS DRAWING IS THE EXCLUSIVE PROPERTY OF MARQUARDT. WITHOUT THEIR CONSENT IT MAY NOT BE REPRODUCED OR GIVEN TO THIRD PARTIES.

Alle Rechte bei Marquardt, auch fuer den Fall von Schutzrechtsanmeldungen. Jede Veruegungsbefugnis, wie Kopier- und Weitergaberecht, bei uns.

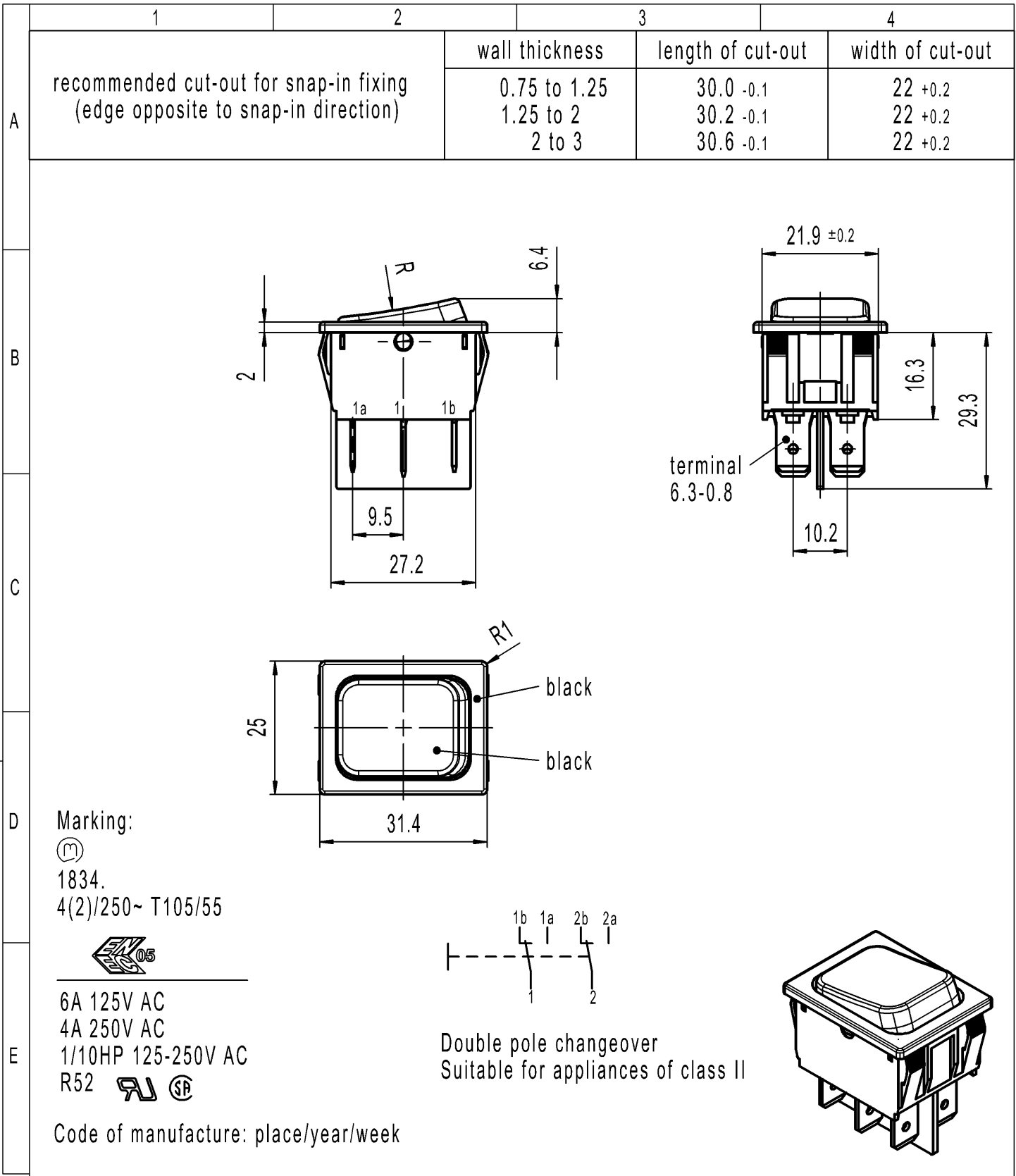

-	-	-	1834.3402-XX
Figure	Type	Customer Part No.	Art.No.-PI
Shape and location	Angle $\pm 2^\circ$	Sheet 01	
	Edge tolerance	Ident. K	Document number 18343402
	Length	Index e	Appliance Switch
e	0-6 $\pm 0.2$	All dimensions are in millimetres	
d	>6-30 $\pm 0.4$		
c	>30 $\pm 0.6$	Format DIN A4	
b	Radii	Projection	
Index	0-6 $\pm 0.2$	Scale 1:1	
MEC-No.	>6-30 $\pm 0.4$	System NX V1872	
Date (YYYY-MM-DD)	>30 $\pm 0.6$		
Date (YYYY-MM-DD)	MATHPATIR	Replacement of	
Date (YYYY-MM-DD)	HHE		
Date (YYYY-MM-DD)	GRH	Zg.gl.Nr.v.03.06.1996	
Date (YYYY-MM-DD)	GRH		
Date (YYYY-MM-DD)	GRH	<b>MARQUARDT</b>	
Date (YYYY-MM-DD)	GRH		