



4VGRu35 300A (115V)

L29-A7 p



**DATA SHEET**

release. 0 - Revision 04-2017

Voltage	Frequency	Input Power	Input Current	Capacitor	Airflow	Rotation speed	Acoustic level	Direction rotation	Admissible Temperature
V	Hz	W	A	µF	m³/h	RPM	dBA	↻	Min/Max
115	50	94	0,82	12,0	1875	1305	55	R	-40°C / +50°C
115	60	103	0,9	12,0	2065	1495	58	R	-40°C / +70°C
115	50				1103 CFM				-40°F / 122°F
115	60				1215 CFM				-40°F / 158°F

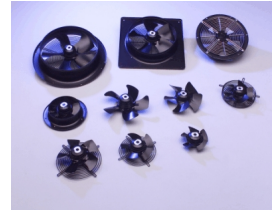

dBa : free blowing

NA : not applicable

ErP 2013

NA

ErP 2015

NA

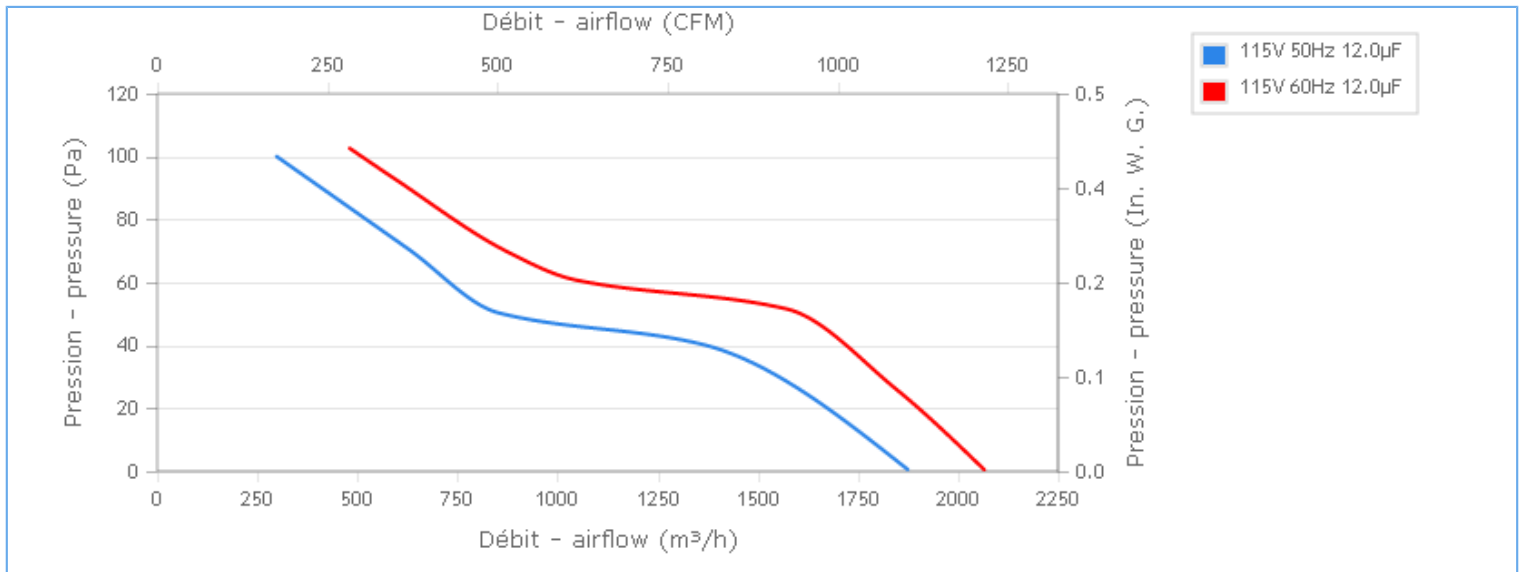
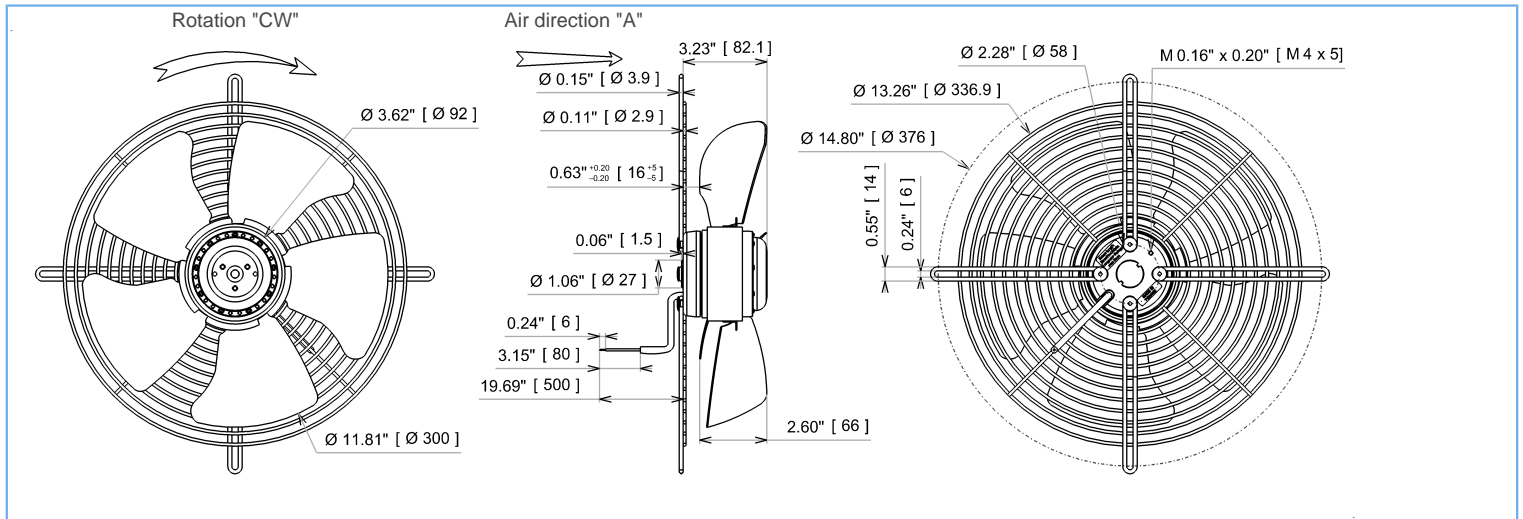

Tested with ECOFIT ring

**Description**

- .Weight : 3,0 Kg
- .Ball bearing
- .Class F, thermally protected
- .IP44 protection depending on installation and position as per EN60034-5
- .G6.3 balancing
- .Zinc coated impeller
- .Rotor and impeller : black paint
- .Finger guard : black paint
- .Motor - UL Recognized component

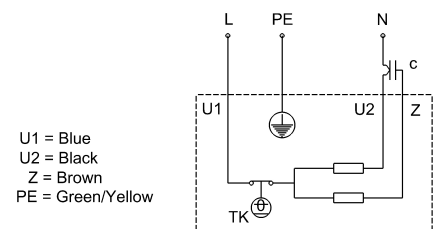

U1 = Blue  
 U2 = Black  
 Z = Brown  
 PE = Green/Yellow



4VGRu35 300A (115V)

L29-A7 p



# DATA SHEET

release. 0 - Revision 04-2017

## Data in accordance to ErP directive

Voltage	115	V
Frequency	50	Hz
Power	0,098	kW <sup>(1)</sup>
Airflow	1362	m <sup>3</sup> /h <sup>(1)</sup>
Pressure	40	Pa <sup>(1)</sup>
Rotation speed	1256	RPM <sup>(1)</sup>

(1) at optimal efficiency point

ErP directive (EU 2009/125/EC) not applicable :  
Power at optimum energy efficiency point

## Accessories

- 19237
- 19237
- 39658
- 09172

## Measurement setup

16086 VIROLE V300 RONDE

## Documents

- Manuel d'utilisation  
[www.ecofit.com/site/normes](http://www.ecofit.com/site/normes)
- Operating and recycling manual  
[www.ecofit.com/anglais/normes](http://www.ecofit.com/anglais/normes)



UL2111 (XEWR2,8)  
N° file E135223  
4RS935



A041865  
4RS935CN

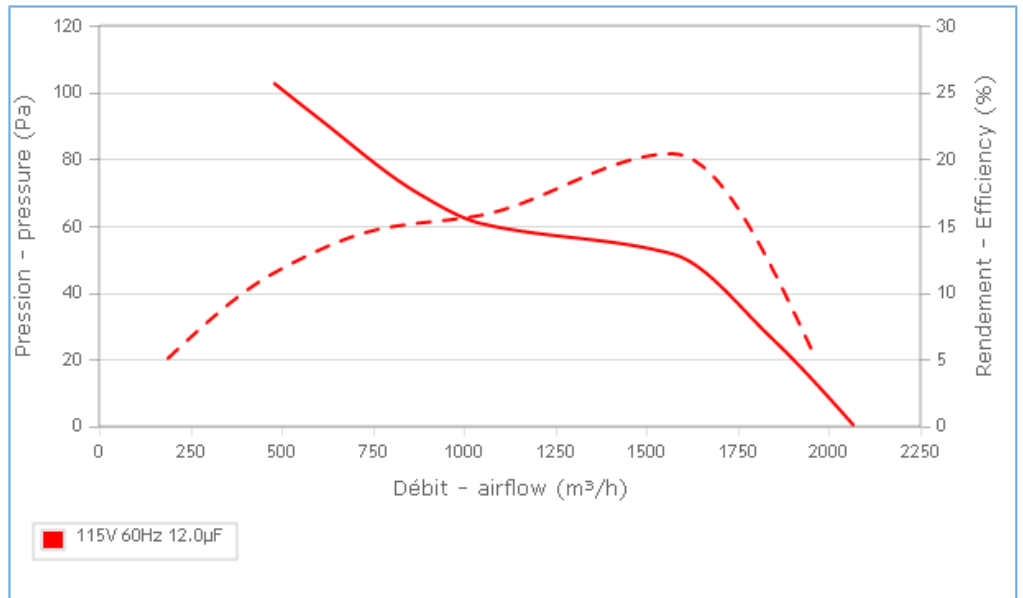
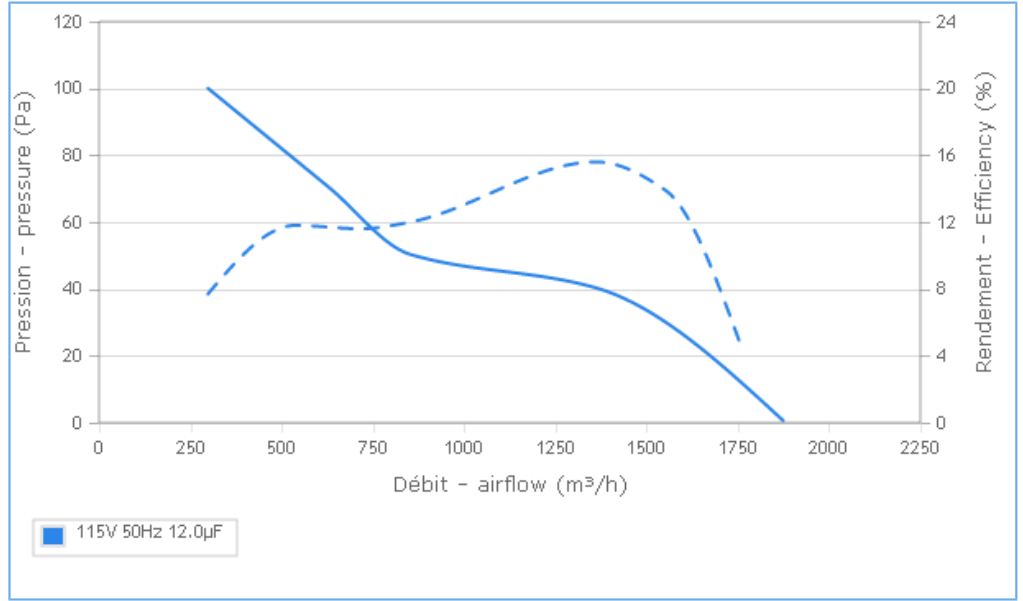

Non contractual document. All specifications are subject to change without prior notice. Picture for information only.