



2VREu25 250A

E27-A3 p

DATA SHEET

release. h - Revision 12-2016

Voltage	Frequency	Input Power	Input Current	Capacitor	Airflow	Rotation speed	Acoustic level	Direction rotation	Admissible Temperature
V	Hz	W	A	µF	m³/h	RPM	dBA	↻	Min/Max
115	50	106	1,06	12,0	1660	2765	67	R	-40°C / +60°C
115	60	143	1,25	12,0	1905	2935	71	R	-40°C / +70°C
115	50				977 CFM				-40°F / 140°F
115	60				1121 CFM				-40°F / 158°F

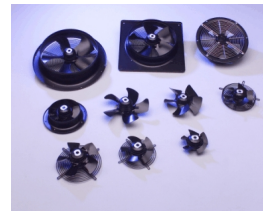

dBA : free blowing

ErP 2013



ErP 2015

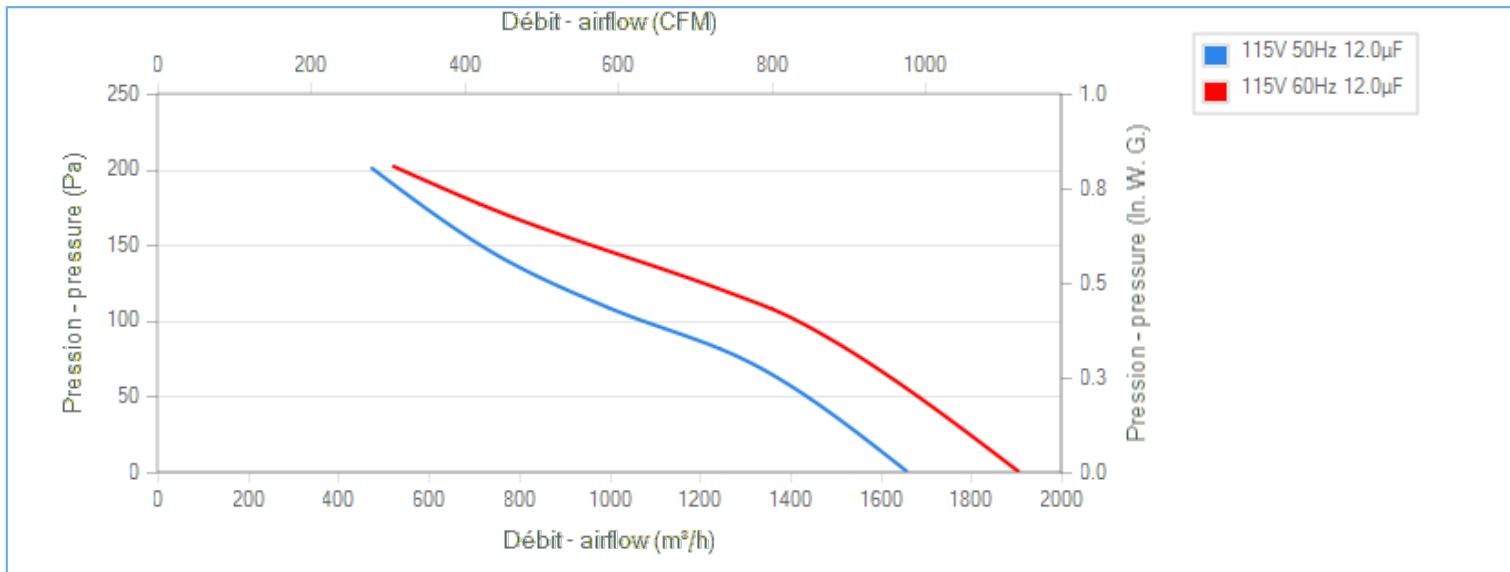
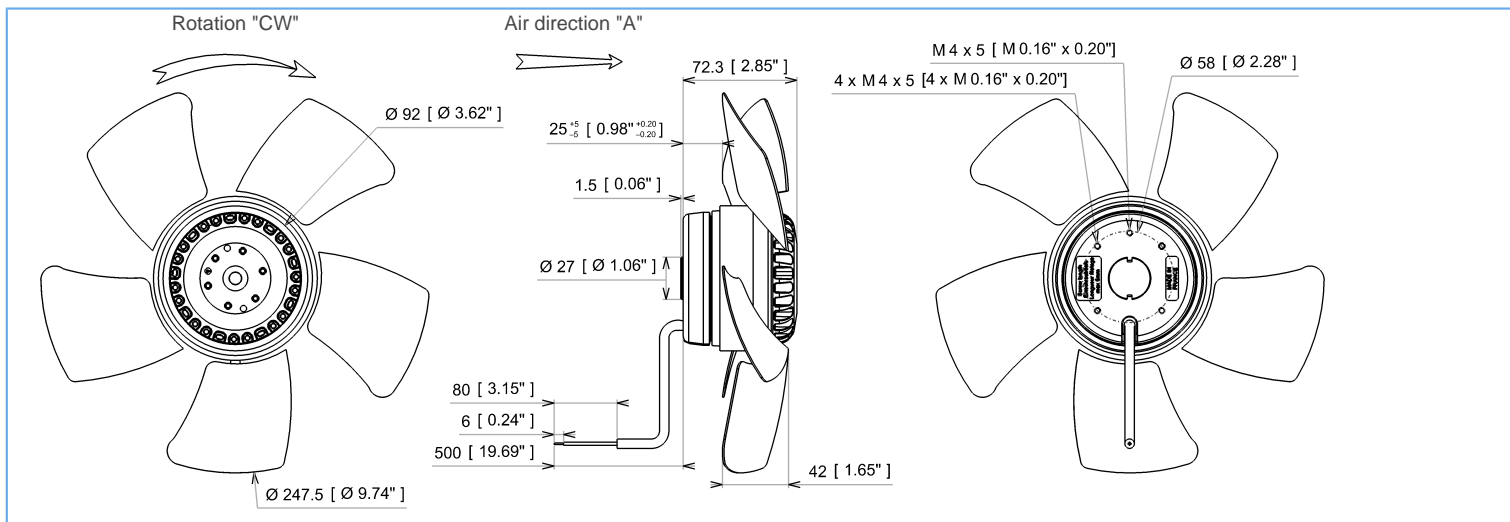

Tested with ECOFIT ring

Description

- .Weight : 1,9 Kg
- .Ball bearing
- .Class F, thermally protected
- .IP44 protection depending on installation and position as per EN60034-5
- .G6.3 balancing
- .Zinc coated impeller
- .Rotor and impeller : black paint
- .Motor - UL Recognized component

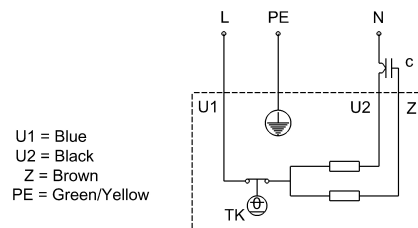

Non contractual document. All specifications are subject to change without prior notice. Picture for information only.



2VREu25 250A

E27-A3 p

DATA SHEET

release. h - Revision 12-2016

Data in accordance to ErP directive

Voltage	115	V
Frequency	50	Hz
Power	0,125	kW ⁽¹⁾
Airflow	1000	m ³ /h ⁽¹⁾
Pressure	108	Pa ⁽¹⁾
Rotation speed	2641	RPM ⁽¹⁾

(1) at optimal efficiency point

Accessories

- 19237
- 19237
- 39658
- 09172

Measurement setup

16085 VIROLE V250 RONDE

Documents

- Manuel d'utilisation
www.ecofit.com/site/normes
- Operating and recycling manual
www.ecofit.com/anglais/normes



UL2111 (XEW2,8)
N° file E135223
2RS925

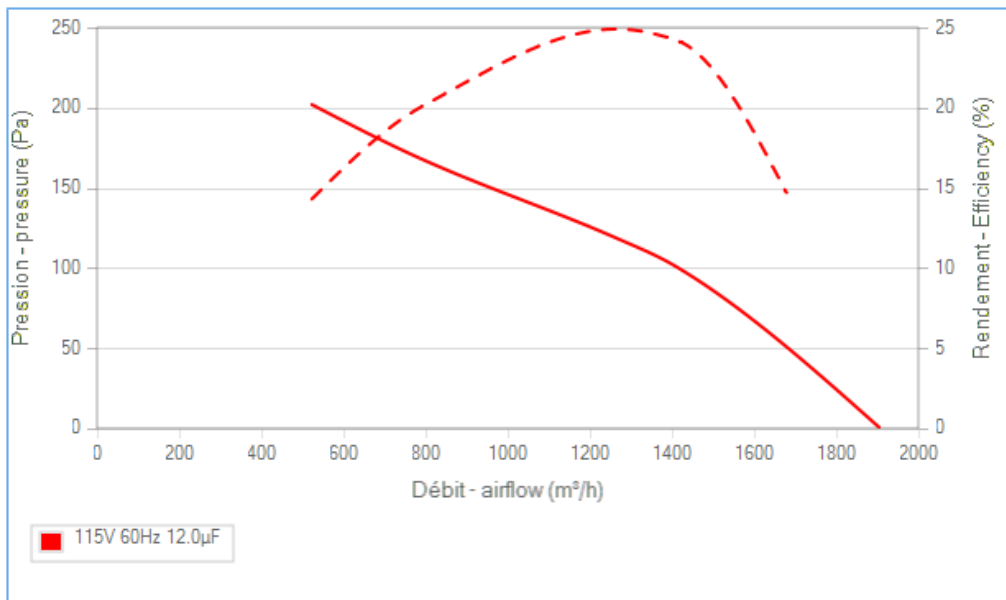
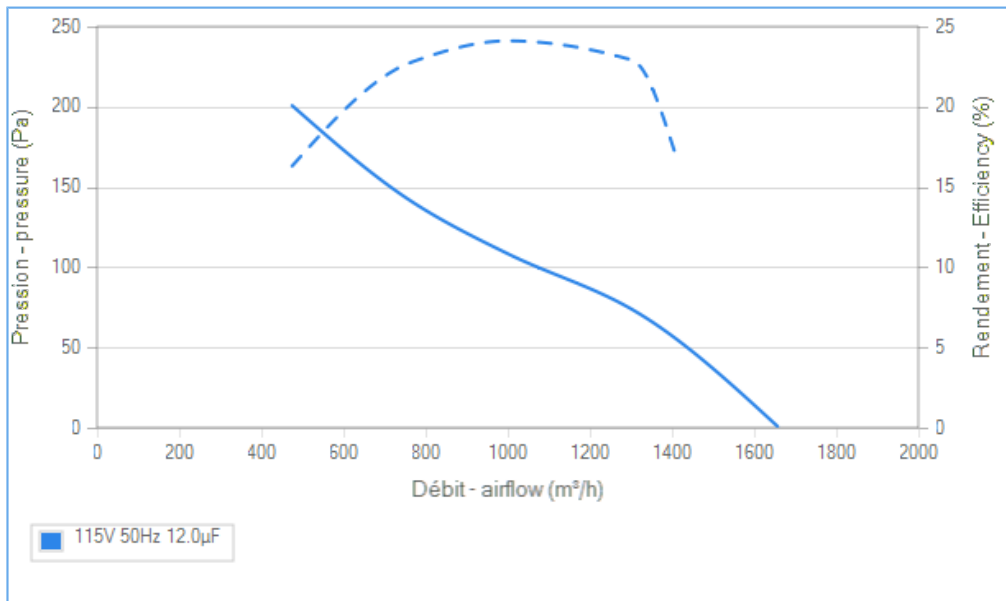

Non contractual document. All specifications are subject to change without prior notice. Picture for information only.