



# RRMuG9 225x50R (120V) S04-A1-1



## DATA SHEET

release. b - Revision 03-2019

Voltage	Frequency	Input Power	Input Current	Airflow	Rotation speed	Direction rotation	Admissible Temperature
V	Hz	W	A	m <sup>3</sup> /h	RPM		Min/Max
120	50/60	141	1,89	1280	3340	R	-25°C / +60°C
120	50/60			753 CFM			-13°F / 140°F

ErP 2013 OK ErP 2015 OK

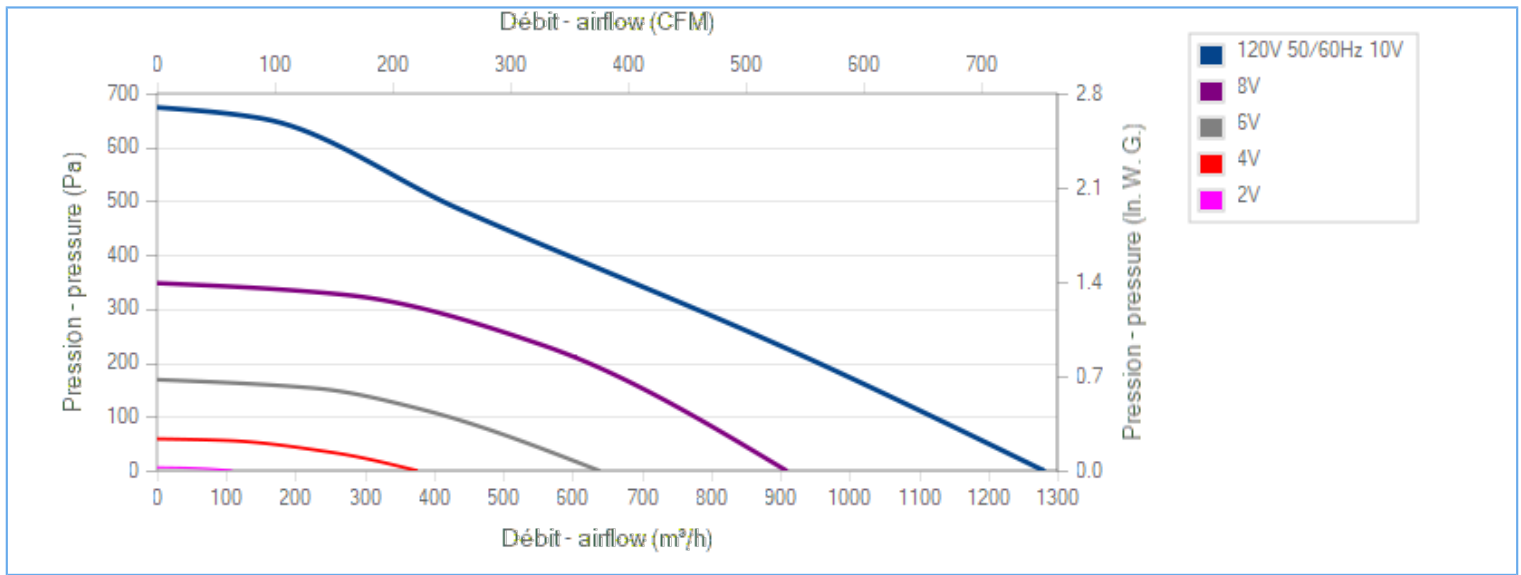
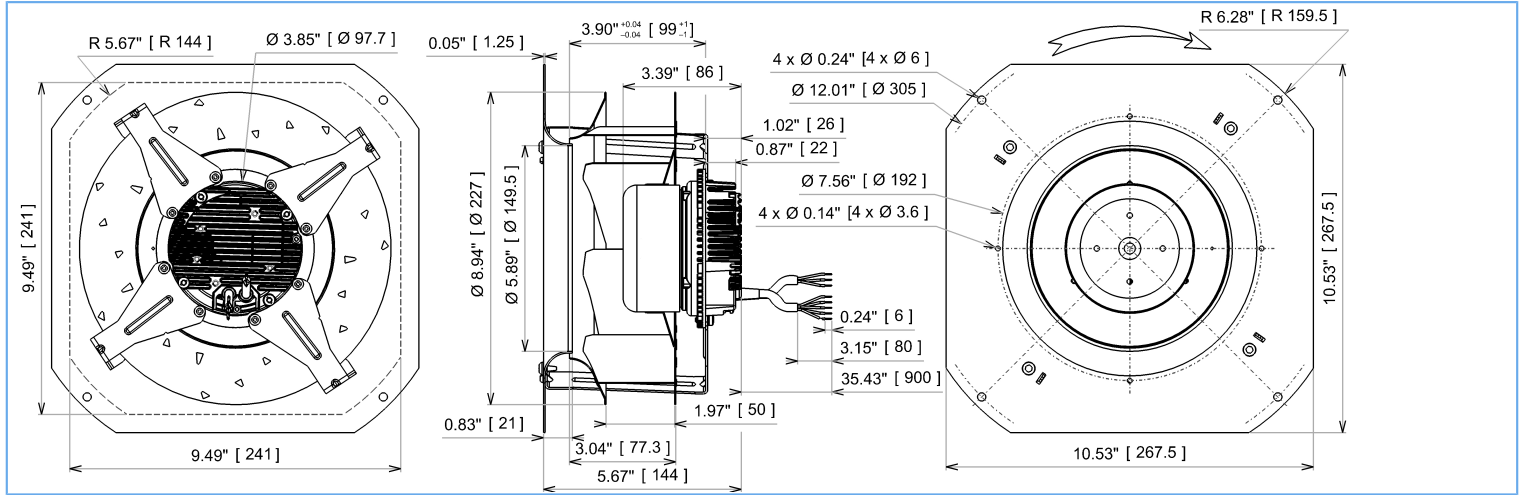
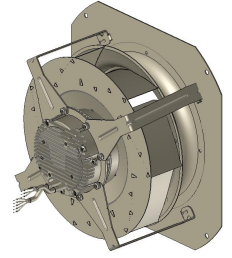

### Description

- .Weight : 2,9 Kg
- .Ball bearing
- .Insulation Class F
- .IP4x may be IP44 according to EN60034-5 after checking the integration into the customer appliance
- .G2.5 balancing
- .Rotor : black paint
- .Galvanized steel impeller

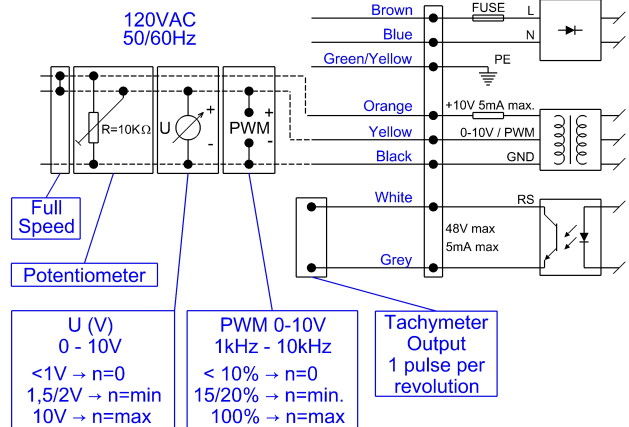



# DATA SHEET

release. b - Revision 03-2019

## Data in accordance to ErP directive

Voltage	120	V
Frequency	50	Hz
Power	0,150	kW <sup>(1)</sup>
Airflow	696	m <sup>3</sup> /h <sup>(1)</sup>
Pressure	344	Pa <sup>(1)</sup>
Rotation speed	2947	RPM <sup>(1)</sup>
(1) at optimal efficiency point		

	Actual	Request 2013	Request 2015
Overall efficiency ( $\eta$ )	50,7	38,8	42,8
Efficiency grade	70	58	62
Installation category	A		
Efficiency category	static		
Variable speed drive	Yes		
Specific ratio	1,00		

Designed for regular application according ErP directive EU 2009/125/EC

## Accessories

21194

## Measurement setup

16236

## Documents

Manuel d'utilisation  
[www.ecofit.com/site/normes](http://www.ecofit.com/site/normes)

Operating and recycling manual  
[www.ecofit.com/anglais/normes](http://www.ecofit.com/anglais/normes)

UL1004-1, 2nd edition "rotating electrical machine"  
 UL1004-3, 1st edition "thermally protected motors"  
 UL1004-7, 2nd edition "electronically protected motors"  
 C22.2 N°100-04, 6th edition "motors and generator"  
 C22.2 N°77-95, 7th edition "motors with inherent overheating protection"  
 UL Motor Model : RT9191  
 File Number : E326930 XDNW2,8

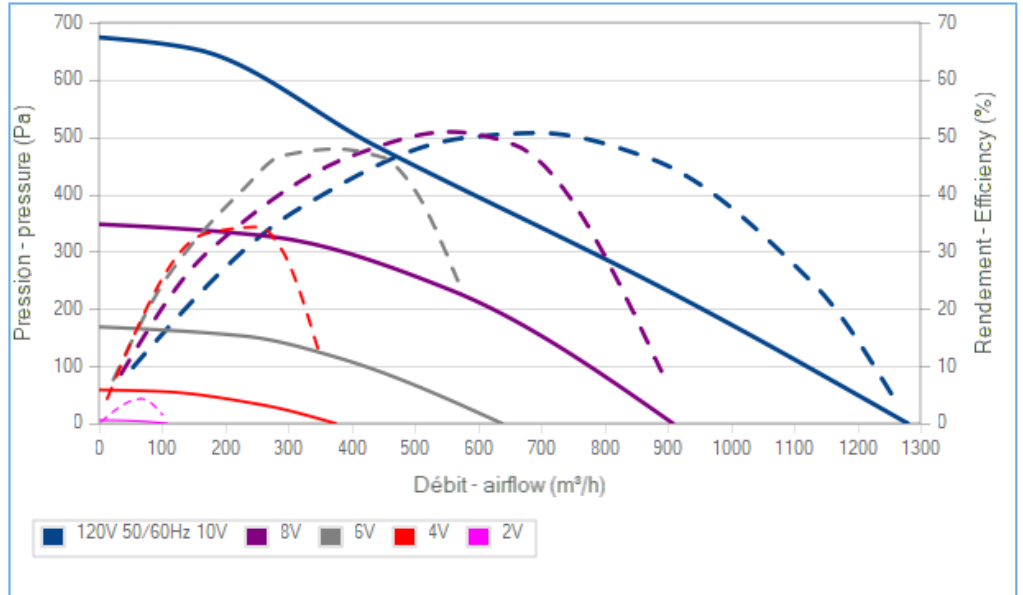
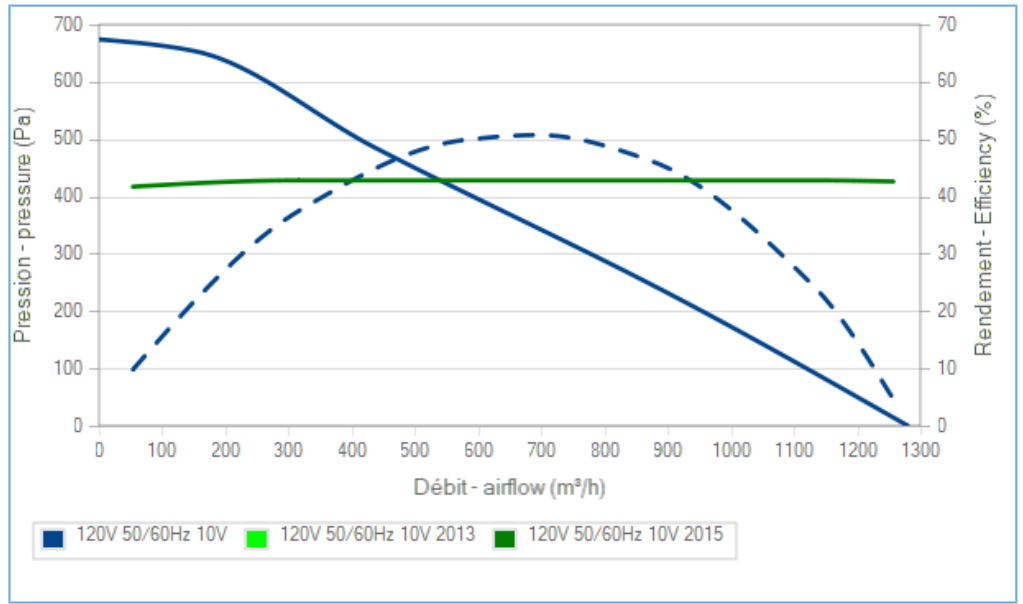

La courbe de rendement intègre le facteur de compensation de charge partielle du règlement (UE) n°327/2011  
 The efficiency curve includes part load compensation factor of regulation (EU) n°327/2011

Non contractual document. All specifications are subject to change without prior notice. Picture for information only.