

# SPECIFICATION FOR APPROVAL

## 规 格 书

Customer (客户): \_\_\_\_\_

Customer part No: \_\_\_\_\_  
(客户料号)

Our part No : \_\_\_\_\_ SP-4008P2  
(本厂型号)

Sample Name : \_\_\_\_\_  
(样品编号)

Date (日期) : \_\_\_\_\_ 2016-05-19

Environment Request: (环境标准)

NON-ROHS (非 ROHS 标准)     ROHS (ROHS 标准)

OTHERS (其它) : \_\_\_\_\_

### CUSTOMER'S APPROVED SIGNATURE

常州青龙电子器件有限公司

SUPPLIER: CHANGZHOU QINGLONG ELECTRONIC COMPONENTS CO.,LTD

TEL(电 话): 86-519-85500395 85500651

FAX(传 真): 86-519-85500519

E-mail: qinlon@263.net <http://www.qinlon.com>

	DESIGNED	CHECKED	APPROVED
SIGNATURE	梁红卫	邹二勇	陆天明
DATE	2016-05-19	2016-05-19	2016-05-19

Preliminary version for reference only

变更历史

Note 序号	Date 日期	Detail changes 变更内容	Reason 变更理由	Revision 变更表示

## Loud Speaker Specification

Part No.	Customer No 顾客型号		Customer code 顾客编号	
	Our Part No 本厂编号	SP-4008P2		Revision 版本 V1.0
No.	Item 项目	Specification 规格	Testing Condition 测试条件	
1.	Rated Imp 共称阻抗	8 Ω ± 15%	At 1 kHz 1.0 Vrms	
2.	Resonance Freq 最低共振周波数	380Hz ± 20%	Without Baffle	
3.	Output S.P.L. 出力音压	90 ± 3 dB	At 0.1m 0.1W 800,1K,1.2K,1.5KHz Average	
4.	Rated Power 定格入力	at 2.00W	at 4.00Vrms	
5.	Max Power 最大入力	at 2.50W	at 4.47Vrms	
6.	Frequency Range 实效频宽	F0----10.0KHz	Output S.P.L. -10dB	
7.	Operation 可靠性试验	Must Be Normal	Program Source 2.0W	
8.	Buzzes & Rattles 异常音试验	Should not be audible buzz and rattle 无异常声	Sine Wave Between (正弦波入力) at 4.00Vrms / F0----10.0KHz	
9.	Distortion 失真	5% Max	Rated Power Input 1000Hz	
10.	Magnet 磁铁	Size: Φ12.5*1.5mm N35 Flux Density: ----- Gauss(高斯)		
11.	Operating Temperature 工作温度	-20℃ to +60℃		
12.	Storage Temperature 储存温度	-30℃ to +60℃		
13.	Weight 重量	10.8g/PCS		

## Our P/N: SP-4008P2

14.	Cold Test 耐寒试验	After having been in a test chamber for 96 hours at the condition of $-20^{\circ}\text{C}\sim 2^{\circ}\text{C}$ and then left 2 hours in a room. ( $-20^{\circ}\text{C}\sim 2^{\circ}\text{C}$ , 96 小时试验室温两小时后, 无异常)
15.	Heat Test 耐热试验	After having been in a test chamber for 96 hours at the condition of $+60^{\circ}\text{C}\sim 2^{\circ}\text{C}$ 90~95% R.H and then left 2 hours in a room. ( $+60^{\circ}\text{C}\sim 2^{\circ}\text{C}$ 90~95% R.H 96 小时试验常温 2 小时后, 无异常的 不良)
16.	Load Test 连续负荷试验	Must be normal after load test :white noise 2.0 W 96 hours. (白噪音 2.0 W 连续 96 小时试验后无异常的 不良)
17	Short Term Maximum Power test 瞬间最大功率测试	Test for 1 hour under maximum power. Input shall be white noise in rated frequency response. And the signal will be 1 second on, 59 seconds off, total 60 cycles. (白噪音 2.5 W, 1 秒开 59 秒关, 连续 60 循环, 试验后无异常之 不良)
18.	Polarity 极性	When a positive D.C current is applied to the voice terminal marked + or white, the diaphragm shall move forward (端子的正极输入电流, 振动板向前方向运动)
19.	Drop Test 跌落试验	Drop the speakers contained in normal box onto a board 5mm thick 10 times from a height of 1.0m . (在厚 5mm 的木板上从 1.0m 的高度跌落 10 次, 无异常 不良)
20.	Terminal strength 端子强度	A static load of 5.0N shall be applied to the terminals for 10s in any direction between terminal block and frame and between terminal block and fasten terminal. (端子板和支架或焊片任一方向上 5.0N 的力 10s 无异常)

### Temperature Cycle Test(5 cycle)

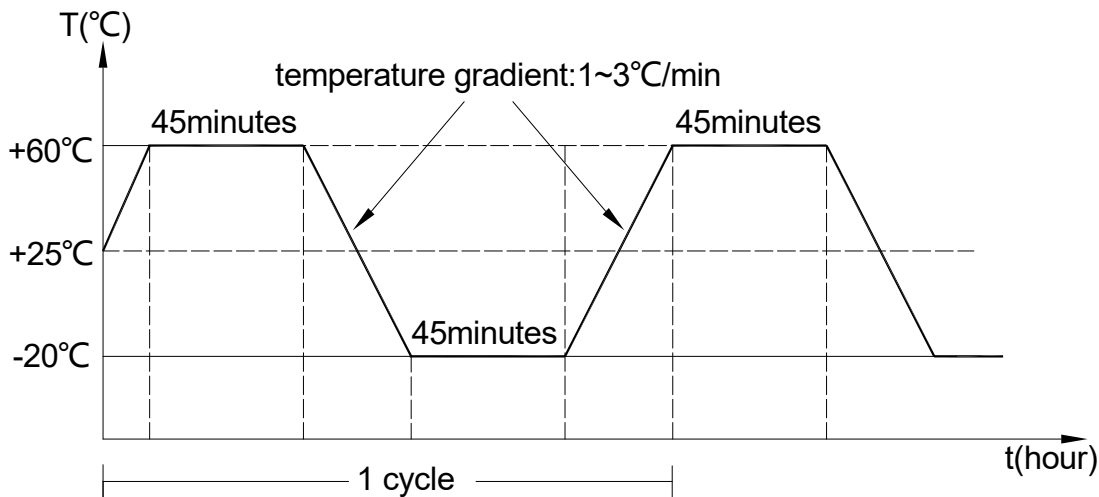

Our P/N: SP-4008P2

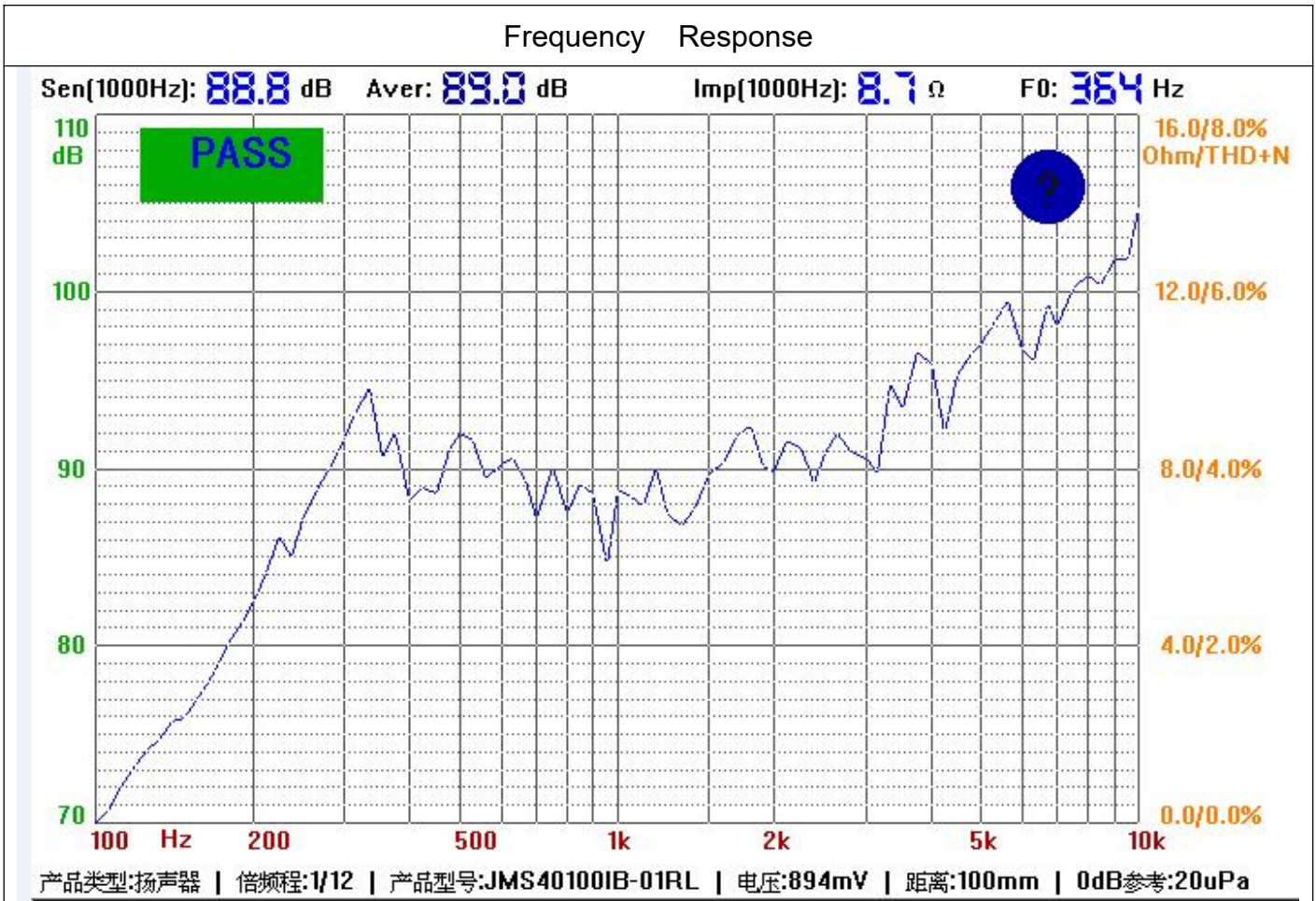

## MEASUREMENT CIRCUIT

### Standard test condition of speaker

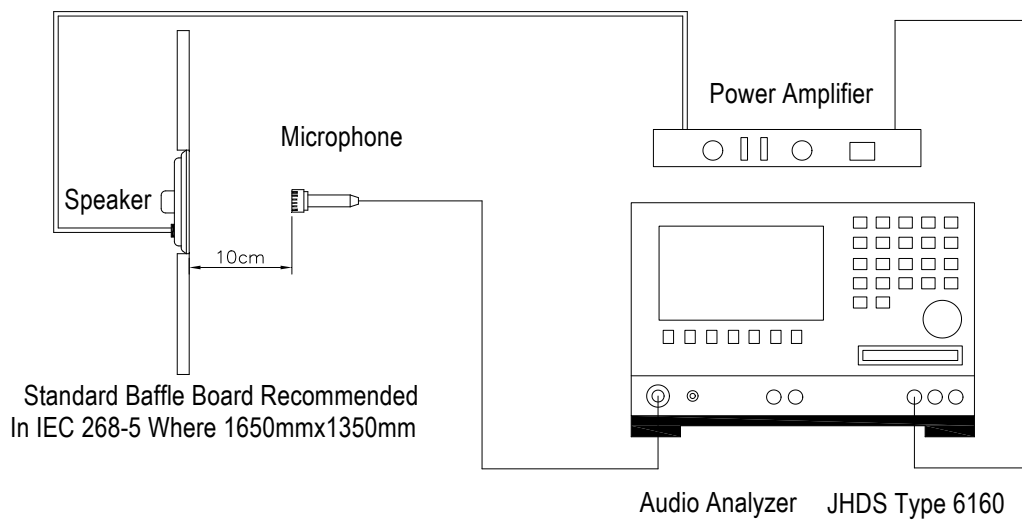

Our P/N: SP-4008P2

Product Outside View

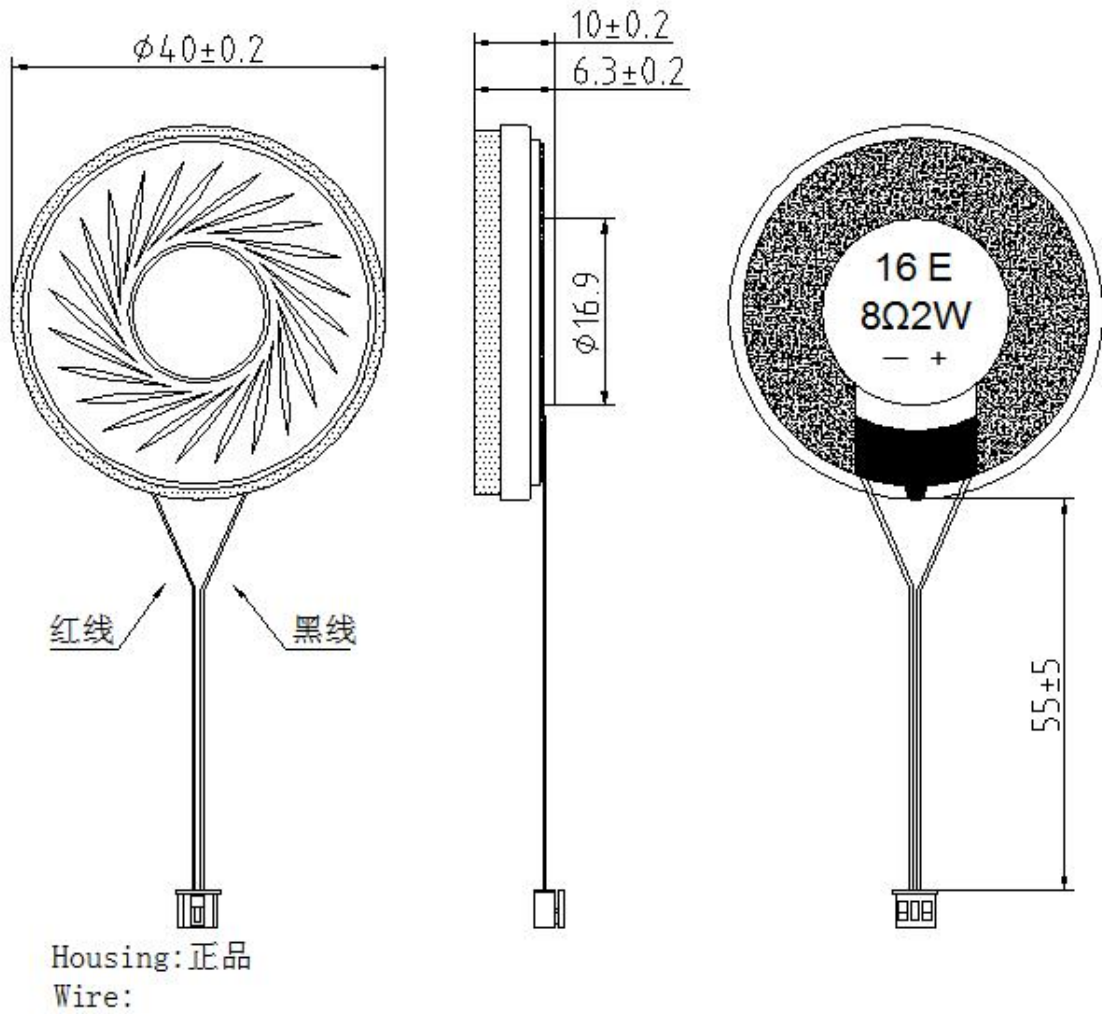

NOTE:  $\pm 0.2$

Unit: mm

### Noise Testing

Testing Method 测试方法	
Item 步骤	Testing Condition 测试条件
1. Testing voltage 测试电压	4.00Vrms
2. Testing Frequency Range 测试频率范围	From F0 to 10.0KHz
3. Testing speed 扫描速度	$S \geq 0.8s/\text{Cycle}$
4. Operation 测试方法	The distance from speaker to tester's ear is 30cm 距离测试者耳朵 30cm 处监听, 声音清纯无异常音为 OK

**Our P/N: SP-4008P2**

**Packing**

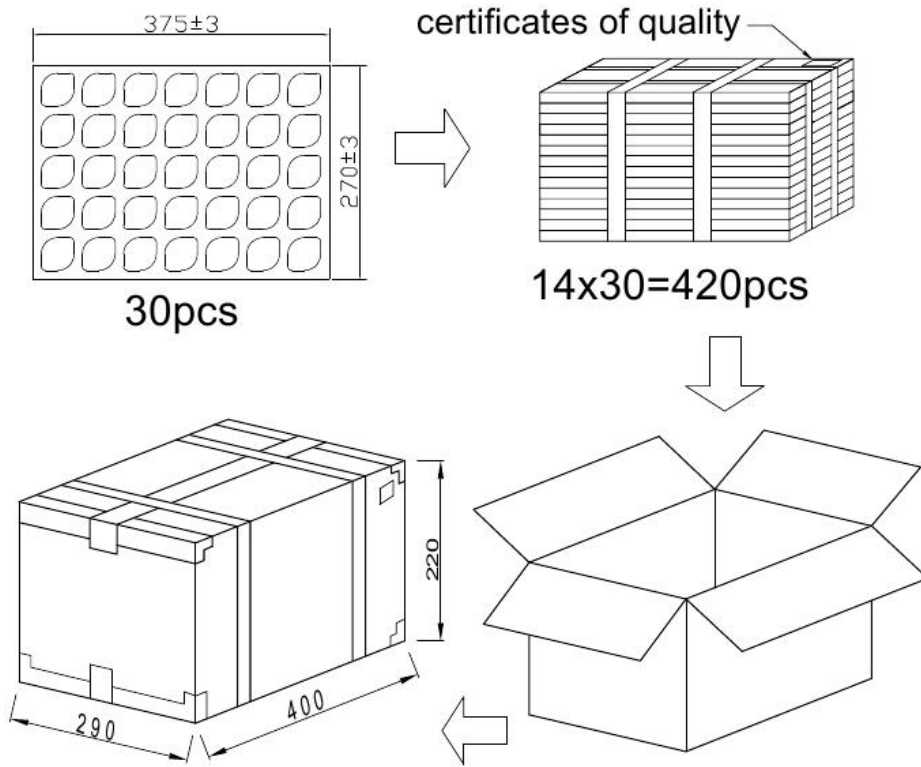

**DAE YOUNG**  
**MADE IN CHINA**

P/N: KP4059SP2  
QTY: 420 PCS  
N.W: 4.5kg  
G.W: 5.8kg  
SIZE: 40 x 27.5 x 22 CM