

OUTLINE

The RP132x Series are voltage-regulators with a built-in low ON-resistance transistor and output current is 1A capability. These ICs have two versions: fixed output voltage type and externally adjustable output voltage type. The minimum output voltage can be set from 1.4V. Otherwise, the load regulation of RP132x has much improved when compared with conventional regulators. It's Typ.5mV at $I_{OUT}=0.1mA$ to 1A.

Each of these ICs consists of a voltage reference unit, an error amplifier, a resistor net for setting output voltage, current limit circuits to prevent over-current and a thermal-shutdown circuit. A standby mode with ultra low supply current can be realized with the chip enable function.

The packages for these ICs are SOT-89-5, HSOP-6J and TO-252-5-P2. They range from high-density mounting to ultra high wattage.

FEATURES

- Input Voltage Range (Maximum Rating)..... 1.4V to 6.5V (7V)
- Operating Temperature Range -40°C to 105°C
- Output Current Min. 1A
- Supply Current Typ. 65 μ A
- Standby Current Typ. 0.15 μ A
- Output Voltage Range..... 0.8V, 1.05V, 1.2V, 1.5V, 1.8V, 2.5V, 3.0V, 3.3V, 5.0V
*Contact our sales representatives for other voltages.
Adjustable Output Voltage Type: 0.8V to 5.5V
- Dropout Voltage Typ. 0.52V ($V_{OUT}=3.0V$, $I_{OUT}=1A$)
- Ripple Rejection Typ. 70dB ($f=1kHz$, $V_{OUT}=3.0V$)
- Output Voltage Accuracy..... $\pm 1.0\%$
- Output Voltage Temperature-Drift Coefficient Typ. $\pm 60ppm/^{\circ}C$
- Line Regulation Typ. 0.052%/V
- Load Regulation Typ. 3mV at $I_{OUT}=300mA$, Typ. 5mV at $I_{OUT}=1A$
- Packages SOT-89-5, HSOP-6J, TO-252-5-P2
- Inrush Current Limit Circuit Typ. 500mA
B/D version: Inrush current limit time is 500 μ s.
- Fold-Back Protection Circuit Typ. 250mA (Current at short mode)
- Thermal Shutdown Circuit Thermal Shutdown Temperature: Typ. 165°C
Released Temperature: Typ. 95°C
- Auto Discharge Function D version
- Ceramic capacitors are recommended to be used with this IC 2.2 μ F or more ($V_{OUT} \leq 3.6V$)
4.7 μ F or more ($V_{OUT} > 3.6V$)

APPLICATIONS

- Power source for accessories such as car audios, car navigation systems, and ETC systems
- Power source for control units including EV inverter and charge control.

BLOCK DIAGRAMS

• Fixed Output Voltage Type (HSOP-6J / SOT-89-5)

RP132Sxx2B / RP132Hxx2B

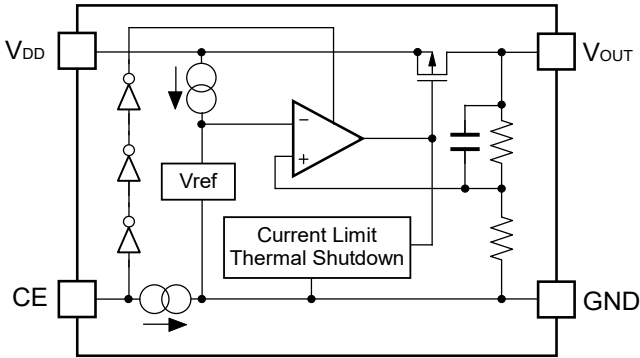

RP132Sxx2D / RP132Hxx2D

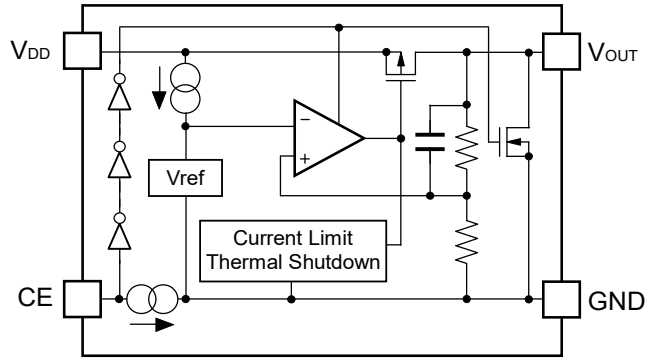

• Fixed Output Voltage Type (TO-252-5-P2)

RP132Jxx1B

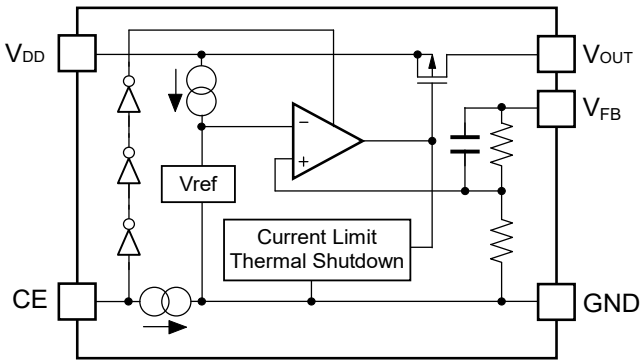

RP132Jxx1D

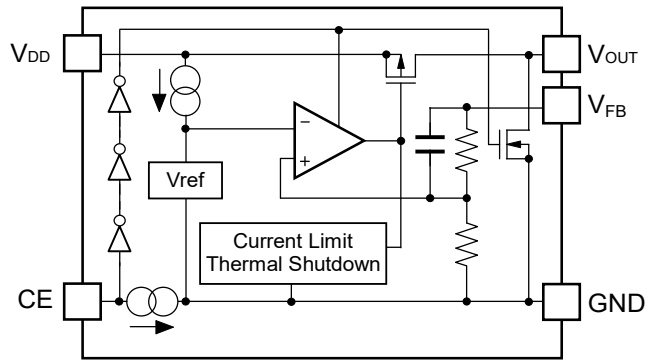

• Adjustable Output Voltage Type (HSOP-6J / SOT-89-5 / TO-252-5-P2)

RP132S001B / RP132H001B / RP132J001B

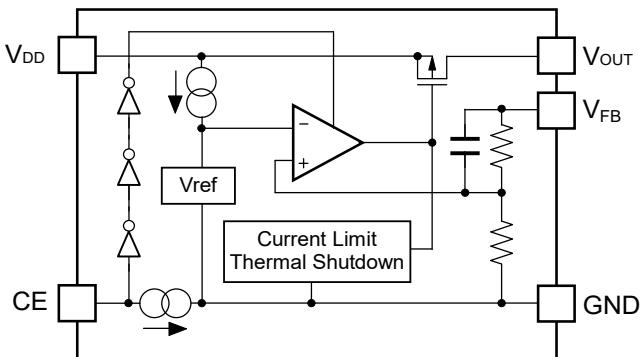

RP132S001D / RP132H001D / RP132J001D

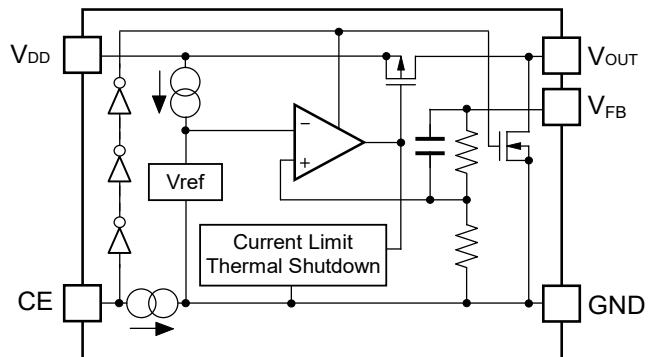

SELECTION GUIDE

The output voltage, the auto discharge function*, and the package type for the ICs can be selected at the user's request.

| Product Name | Package | Quantity per Reel | Pb Free | Halogen Free |
|------------------|-------------|-------------------|---------|--------------|
| RP132H001*-T1-#E | SOT-89-5 | 1,000 pcs | Yes | Yes |
| RP132Hxx2*-T1-#E | | | | |
| RP132S001*-E2-#E | HSOP-6J | 1,000 pcs | Yes | Yes |
| RP132Sxx2*-E2-#E | | | | |
| RP132J001*-T1-#E | TO-252-5-P2 | 3,000 pcs | Yes | Yes |
| RP132Jxx1*-T1-#E | | | | |

RP132x001x is the adjustable output voltage type.

xx: Specify the set output voltage (V_{SET}) of the fixed output voltage type.

0.8V(08), 1.2V(12), 1.5V(15), 1.8V(18), 2.5V(25), 3.0V(30), 3.3V(33), 5.0V(50)

1.05V(RP132x10xx5)

*Contact our sales representatives for other voltages.

*: The auto discharge function at off state options are as follows.

(B) without auto discharge function* at off state

(D) with auto discharge function* at off state

: Specify Automotive Class Code

| | Operating Temperature Range | Guaranteed Specs Temperature Range | Screening |
|---|-----------------------------|------------------------------------|--------------------------|
| A | -40°C to 105°C | 25°C | High Temperature |
| J | -40°C to 105°C | -40°C to 105°C | High and Low Temperature |

* Auto-discharge function quickly lowers the output voltage to 0V, when the chip enable signal is switched from the active mode to the standby mode, by releasing the electrical charge accumulated in the external capacitor.

PIN DESCRIPTIONS

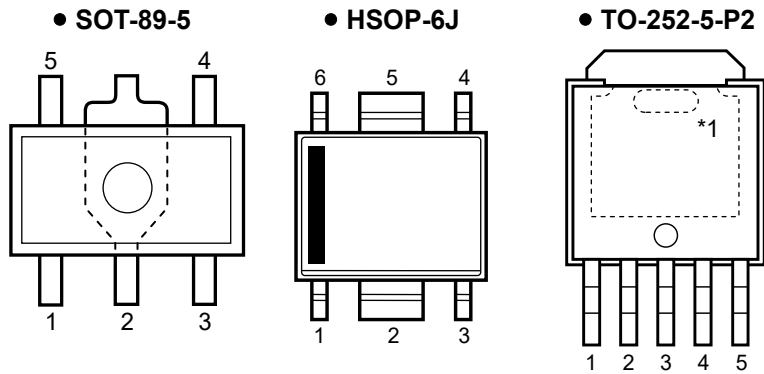

● **SOT-89-5**

| Pin No. | Symbol | Pin Description |
|---------|------------------|---|
| 1 | CE | Chip Enable Pin ("H" Active) (RP132Hxx2B/D) |
| | V _{FB} | Feed Back Pin (RP132H001B/D) |
| 2 | GND | Ground Pin |
| 3 | GND | Ground Pin (RP132Hxx2B/D) |
| | CE | Chip Enable Pin ("H" Active) (RP132H001B/D) |
| 4 | V _{DD} | Input Pin |
| 5 | V _{OUT} | Output Pin |

When using Fixed Output Voltage Type (RP132Hxx2x), No.2 pin and No. 3 pin must be wired each other when mounted on boards. When using Adjustable Output Voltage Type (RP132H001x), please follow "Notes on Adjustable Output Voltage Type Settings".

● **HSOP-6J**

| Pin No. | Symbol | Pin Description |
|---------|------------------|------------------------------|
| 1 | V _{OUT} | Output Pin |
| 2 | GND | Ground Pin |
| 3 | GND | Ground Pin (RP132Sxx2B/D) |
| | V _{FB} | Feed Back Pin (RP132S001B/D) |
| 4 | CE | Chip Enable Pin ("H" Active) |
| 5 | GND | Ground Pin |
| 6 | V _{DD} | Input Pin |

When using Fixed Output Voltage Type (RP132Hxx2x), No.2 pin, No. 3 pin, and No.5 pin must be wired each other when mounted on boards. When using Adjustable Output Voltage Type (RP132S001x), please follow "Notes on Adjustable Output Voltage Type Settings".

● TO-252-5-P2

| Pin No. | Symbol | Pin Description |
|---------|------------------|------------------------------|
| 1 | CE | Chip Enable Pin ("H" Active) |
| 2 | V _{DD} | Input Pin |
| 3 | GND | Ground Pin |
| 4 | V _{OUT} | Output Pin |
| 5 | V _{FB} | Feed Back Pin |

*1 Tab is GND level. (They are connected to the reverse side of this IC.) The tab is better to be connected to the GND, but leaving it open is also acceptable.

When using Fixed Output Voltage Type(RP132Jxx1x), V_{OUT} pin and V_{FB} pin should be connected. When using Adjustable Output Voltage Type (RP132J001x), please follow "Notes on the Adjustable Output Voltage Type Settings".

ABSOLUTE MAXIMUM RATINGS

| Symbol | Item | | Rating | Unit | |
|------------------|-------------------------------------|-------------|------------------------------|------|----|
| V _{IN} | Input Voltage | | 7.0 | V | |
| V _{CE} | Input Voltage (CE Pin) | | -0.3 to 7.0 | V | |
| V _{FB} | Input Voltage (V _{FB} Pin) | | -0.3 to 7.0 | V | |
| V _{OUT} | Output Voltage | | -0.3 to V _{IN} +0.3 | V | |
| P _D | Power Dissipation* | SOT-89-5 | JEDEC STD. 51 | 3200 | mW |
| | | HSOP-6J | JEDEC STD. 51 | 3400 | |
| | | TO-252-5-P2 | JEDEC STD. 51 | 4800 | |
| T _j | Junction Temperature | | -40 to 150 | °C | |
| T _{stg} | Storage Temperature Range | | -55 to 150 | °C | |

*) Refer to *PACKAGE INFORMATION* for detailed information.

ABSOLUTE MAXIMUM RATINGS

Electronic and mechanical stress momentarily exceeded absolute maximum ratings may cause permanent damage and may degrade the life time and safety for both device and system using the device in the field. The functional operation at or over these absolute maximum ratings is not assured.

RECOMMENDED OPERATING CONDITIONS

| Symbol | Item | Rating | Unit |
|-----------------|-----------------------------|------------|------|
| V _{IN} | Input Voltage | 1.4 to 6.5 | V |
| T _a | Operating Temperature Range | -40 to 105 | °C |

RECOMMENDED OPERATING CONDITIONS

All of electronic equipment should be designed that the mounted semiconductor devices operate within the recommended operating conditions. The semiconductor devices cannot operate normally over the recommended operating conditions, even if they are used over such conditions by momentary electronic noise or surge. And the semiconductor devices may receive serious damage when they continue to operate over the recommended operating conditions.

ELECTRICAL CHARACTERISTICS

$V_{IN}=V_{SET}+1.0V$, $I_{OUT}=1mA$, $C_{IN}=2.2\mu F$, $C_{OUT}=2.2\mu F$ ($V_{SET} \leq 3.6V$), $4.7\mu F$ ($V_{SET} > 3.6V$), unless otherwise noted.
 The specifications surrounded by are guaranteed by design engineering at $-40^{\circ}C \leq T_a \leq 105^{\circ}C$.

● **RP132xxxxB/D (-AE) (Fixed Output Voltage Type)**

($T_a=25^{\circ}C$)

| Symbol | Item | Conditions | Min. | Typ. | Max. | Unit | |
|---|--|---|---|--|--|--|----|
| V_{OUT} | Output Voltage | $T_a=25^{\circ}C$ | $V_{OUT} > 1.5V$ | $\times 0.99$ | | $\times 1.01$ | V |
| | | | $V_{OUT} \leq 1.5V$ | -15 | | 15 | mV |
| | | $-40^{\circ}C \leq T_a \leq 105^{\circ}C$ | $V_{OUT} > 1.5V$ | ×0.981 | | ×1.019 | V |
| | | | $V_{OUT} \leq 1.5V$ | -29 | | 29 | mV |
| I_{LIM} | Output Current Limit | | 1 | | | A | |
| $\frac{\Delta V_{OUT}}{\Delta I_{OUT}}$ | Load Regulation | $0.1mA \leq I_{OUT} \leq 300mA$ | | 3 | 20 | mV | |
| | | $0.1mA \leq I_{OUT} \leq 1A$ | | 5 | 60 | | |
| V_{DIF} | Dropout Voltage | Refer to the <i>Product-specific Electrical Characteristics</i> | | | | | |
| I_{SS} | Supply Current | $I_{OUT}=0mA$ ($V_{IN}=6.5V$) | | 65 | 85 | μA | |
| $I_{standby}$ | Standby Current | $V_{CE}=0V$, $V_{IN}=6.5V$ | | 0.15 | 0.60 | μA | |
| $\frac{\Delta V_{OUT}}{\Delta V_{IN}}$ | Line Regulation | Set $V_{OUT}+0.5V \leq V_{IN} \leq 6.5V$ * However, $V_{IN} \geq 1.6V$ | | 0.05 | 0.10 | %/V | |
| I_{SC} | Short Current Limit | $V_{OUT}=0V$ | | 250 | | mA | |
| I_{PD} | CE Pull-down Current | | | 0.3 | 0.7 | μA | |
| V_{CEH} | CE Input Voltage "H" | | 1.0 | | | V | |
| V_{CEL} | CE Input Voltage "L" | | | | 0.4 | V | |
| T_{TSD} | Thermal Shutdown Detection Temperature | Junction Temperature | | 165 | | $^{\circ}C$ | |
| T_{TSR} | Thermal Shutdown Released Temperature | Junction Temperature | | 95 | | $^{\circ}C$ | |
| R_{LOW} | Low Output Nch Tr. ON Resistance (D version) | $V_{IN}=4.0V$, $V_{CE}=0V$ | | 50 | | Ω | |

All test items listed under Electrical Characteristics are done under the pulse load condition ($T_j \approx T_a = 25^{\circ}C$) except for Dropout Voltage and Load Regulation at 1A Output Current.

RP132x

NO.EC-265-190408

The specifications surrounded by are guaranteed by design engineering at $-40^{\circ}\text{C} \leq T_a \leq 105^{\circ}\text{C}$.**RP132xxxxB/D (-AE) (Fixed Output Voltage Type) Product-specific Electrical Characteristics** ($T_a = 25^{\circ}\text{C}$)

| Product Name | V_{OUT} [V] ($T_a = 25^{\circ}\text{C}$) | | | V_{OUT} [V] ($T_a = -40$ to 105°C) | | | V_{DIF} [V] ($I_{\text{out}} = 300$ mA) | | V_{DIF} [V] ($I_{\text{out}} = 1$ A) | |
|--------------|--|-------|-------|---|-------|---|--|--|---|--|
| | MIN. | TYP. | MAX. | MIN. | TYP. | MAX. | TYP. | MAX. | TYP. | MAX. |
| RP132x08xx | 0.785 | 0.800 | 0.815 | 0.771 | 0.800 | 0.829 | 0.67 | 0.89 | 1.20 | 1.54 |
| RP132x12xx | 1.185 | 1.200 | 1.215 | 1.171 | 1.200 | 1.229 | 0.36 | 0.54 | 0.90 | 1.23 |
| RP132x15xx | 1.485 | 1.500 | 1.515 | 1.471 | 1.500 | 1.529 | 0.24 | 0.33 | 0.78 | 1.05 |
| RP132x18xx | 1.782 | 1.800 | 1.818 | 1.766 | 1.800 | 1.834 | | | | |
| RP132x25xx | 2.475 | 2.500 | 2.525 | 2.453 | 2.500 | 2.548 | | | | |
| RP132x30xx | 2.970 | 3.000 | 3.030 | 2.943 | 3.000 | 3.057 | 0.15 | 0.21 | 0.52 | 0.72 |
| RP132x33xx | 3.267 | 3.300 | 3.333 | 3.237 | 3.300 | 3.363 | 0.13 | 0.18 | 0.46 | 0.68 |
| RP132x50xx | 4.950 | 5.000 | 5.050 | 4.905 | 5.000 | 5.095 | | | | |
| RP132x10xx5 | 1.035 | 1.050 | 1.065 | 1.021 | 1.050 | 1.079 | 0.51 | 0.73 | 1.05 | 1.39 |

$V_{IN} = V_{SET} + 1.0V$, $I_{OUT} = 1mA$, $C_{IN} = 2.2\mu F$, $C_{OUT} = 2.2\mu F (V_{OUT} \leq 3.6V)$, $4.7\mu F (V_{OUT} > 3.6V)$, unless otherwise noted.
 The specifications surrounded by are guaranteed by design engineering at $-40^{\circ}C \leq T_a \leq 105^{\circ}C$.

● **RP132x001B/D (-AE) (Adjustable Output Voltage Type)**

($T_a = 25^{\circ}C$)

| Symbol | Item | Conditions | | Min. | Typ. | Max. | Unit |
|---|--|--|--------------------|---|-------|---|-------------|
| V_{FB} | Feedback Voltage | $T_a = 25^{\circ}C$ | $V_{OUT} = V_{FB}$ | 0.785 | 0.800 | 0.815 | V |
| | | $-40^{\circ}C \leq T_a \leq 105^{\circ}C$ | | 0.771 | | 0.829 | |
| V_{OUT} | Output Voltage Adjusting Range | | | 0.8 | | 5.5 | V |
| I_{LIM} | Output Current Limit | $V_{OUT} = V_{FB}$ | | 1 | | | A |
| $\frac{\Delta V_{OUT}}{\Delta I_{OUT}}$ | Load Regulation | $0.1mA \leq I_{OUT} \leq 300mA$ | | | 3 | 20 | mV |
| | | $0.1mA \leq I_{OUT} \leq 1A$ | | | 5 | 60 | |
| V_{DIF} | Dropout Voltage | $V_{OUT} = V_{FB}$ | $I_{OUT} = 300mA$ | | 0.67 | 0.89 | V |
| | | | $I_{OUT} = 1A$ | | 1.20 | 1.54 | |
| I_{SS} | Supply Current | $V_{OUT} = V_{FB}$, $I_{OUT} = 0mA$ ($V_{IN} = 6.5V$) | | | 65 | 85 | μA |
| $I_{standby}$ | Standby Current | $V_{CE} = 0V$, $V_{IN} = 6.5V$ | | | 0.15 | 0.60 | μA |
| $\frac{\Delta V_{OUT}}{\Delta V_{IN}}$ | Line Regulation | $V_{OUT} = V_{FB}$, $1.6V \leq V_{IN} \leq 6.5V$ | | | 0.05 | 0.10 | %/V |
| I_{SC} | Short Current Limit | $V_{OUT} = V_{FB} = 0V$ | | | 250 | | mA |
| I_{PD} | CE Pull-down Current | | | | 0.3 | 0.7 | μA |
| V_{CEH} | CE Input Voltage "H" | | | 1.0 | | | V |
| V_{CEL} | CE Input Voltage "L" | | | | | 0.4 | V |
| T_{TSD} | Thermal Shutdown Detection Temperature | Junction Temperature | | | 165 | | $^{\circ}C$ |
| T_{TSR} | Thermal Shutdown Released Temperature | Junction Temperature | | | 95 | | $^{\circ}C$ |
| R_{LOW} | Low Output Nch Tr. ON Resistance (D version) | $V_{IN} = 4.0V$, $V_{CE} = 0V$ | | | 50 | | Ω |

All test items listed under Electrical Characteristics are done under the pulse load condition ($T_j \approx T_a = 25^{\circ}C$) except for Dropout Voltage and Load Regulation at 1A Output Current.

RP132x

NO.EC-265-190408

$V_{IN} = V_{SET} + 1.0V$, $I_{OUT} = 1mA$, $C_{IN} = 2.2\mu F$, $C_{OUT} = 2.2\mu F (V_{OUT} \leq 3.6V)$, $4.7\mu F (V_{OUT} > 3.6V)$, unless otherwise noted.
 The specifications surrounded by are guaranteed by design engineering at $-40^{\circ}C \leq T_a \leq 105^{\circ}C$.

• RP132xxxxB/D (-JE) (Fixed Output Voltage Type)
 $(-40^{\circ}C \leq T_a \leq 105^{\circ}C)$

| Symbol | Item | Conditions | Min. | Typ. | Max. | Unit | | |
|---|--|---|---|----------------|--|---------------|----------------|----|
| V_{OUT} | Output Voltage | $T_a = 25^{\circ}C$ | $V_{SET} > 1.5V$ | $\times 0.99$ | | $\times 1.01$ | V | |
| | | | $V_{SET} \leq 1.5V$ | -15 | | 15 | mV | |
| | | $-40^{\circ}C \leq T_a \leq 105^{\circ}C$ | $V_{SET} > 1.5V$ | $\times 0.981$ | | | $\times 1.019$ | V |
| | | | $V_{SET} \leq 1.5V$ | -29 | | | 29 | mV |
| I_{LIM} | Output Current Limit | | 1 | | | A | | |
| $\frac{\Delta V_{OUT}}{\Delta I_{OUT}}$ | Load Regulation | $0.1mA \leq I_{OUT} \leq 300mA$ | | 3 | 20 | mV | | |
| | | $0.1mA \leq I_{OUT} \leq 1A$ | | 5 | 60 | | | |
| V_{DIF} | Dropout Voltage | Refer to the <i>Product-specific Electrical Characteristics</i> | | | | | | |
| I_{SS} | Supply Current | $I_{OUT} = 0mA (V_{IN} = 6.5V)$ | | 65 | 85 | μA | | |
| $I_{standby}$ | Standby Current | $V_{CE} = 0V, V_{IN} = 6.5V$ | $T_a = 25^{\circ}C$ | | 0.15 | 0.6 | μA | |
| | | | $-40^{\circ}C \leq T_a \leq 105^{\circ}C$ | | | 4.0 | μA | |
| $\frac{\Delta V_{OUT}}{\Delta V_{IN}}$ | Line Regulation | $V_{SET} + 0.5V \leq V_{IN} \leq 6.5V$, * However, $V_{IN} \geq 1.6V$ | | 0.05 | 0.10 | %/V | | |
| I_{SC} | Short Current Limit | $V_{OUT} = 0V$ | | 250 | | mA | | |
| I_{PD} | CE Pull-down Current | | | 0.3 | 0.7 | μA | | |
| V_{CEH} | CE Input Voltage "H" | | 1.0 | | | V | | |
| V_{CEL} | CE Input Voltage "L" | | | | 0.4 | V | | |
| T_{TSD} | Thermal Shutdown Detection Temperature | Junction Temperature | | 165 | | $^{\circ}C$ | | |
| T_{TSR} | Thermal Shutdown Released Temperature | Junction Temperature | | 95 | | $^{\circ}C$ | | |
| R_{LOW} | Low Output Nch Tr. ON Resistance (D version) | $V_{IN} = 4.0V, V_{CE} = 0V$ | | 50 | | Ω | | |

All test items listed under Electrical Characteristics are done except for Dropout Voltage and Load Regulation at 1A Output Current.

The specifications surrounded by are guaranteed by design engineering at $-40^{\circ}\text{C} \leq T_a \leq 105^{\circ}\text{C}$.

RP132xxxxB/D (-JE) (Fixed Output Voltage Type) Product-specific Electrical Characteristics ($-40^{\circ}\text{C} \leq T_a \leq 105^{\circ}\text{C}$)

| Product Name | V _{OUT} [V] (T _a = 25°C) | | | V _{OUT} [V] (T _a = -40 to 105°C) | | | V _{DIF} [V] (I _{out} = 300 mA) | | V _{DIF} [V] (I _{out} = 1 A) | |
|--------------|---|-------|-------|---|-------|-------|---|------|--|--|
| | MIN. | TYP. | MAX. | MIN. | TYP. | MAX. | TYP. | MAX. | TYP. | MAX. |
| RP132x08xx | 0.785 | 0.800 | 0.815 | 0.771 | 0.800 | 0.829 | 0.67 | 0.89 | 1.20 | 1.54 |
| RP132x12xx | 1.185 | 1.200 | 1.215 | 1.171 | 1.200 | 1.229 | 0.36 | 0.54 | 0.90 | 1.23 |
| RP132x15xx | 1.485 | 1.500 | 1.515 | 1.471 | 1.500 | 1.529 | 0.24 | 0.33 | 0.78 | 1.05 |
| RP132x18xx | 1.782 | 1.800 | 1.818 | 1.766 | 1.800 | 1.834 | | | | |
| RP132x25xx | 2.475 | 2.500 | 2.525 | 2.453 | 2.500 | 2.548 | | | | |
| RP132x30xx | 2.970 | 3.000 | 3.030 | 2.943 | 3.000 | 3.057 | 0.15 | 0.21 | 0.52 | 0.72 |
| RP132x33xx | 3.267 | 3.300 | 3.333 | 3.237 | 3.300 | 3.363 | 0.13 | 0.18 | 0.46 | 0.68 |
| RP132x50xx | 4.950 | 5.000 | 5.050 | 4.905 | 5.000 | 5.095 | | | | |
| RP132x10xx5 | 1.035 | 1.050 | 1.065 | 1.021 | 1.050 | 1.079 | 0.51 | 0.73 | 1.05 | 1.39 |

RP132x

NO.EC-265-190408

$V_{IN} = V_{SET} + 1.0V$, $I_{OUT} = 1mA$, $C_{IN} = 2.2\mu F$, $C_{OUT} = 2.2\mu F (V_{OUT} \leq 3.6V)$, $4.7\mu F (V_{OUT} > 3.6V)$, unless otherwise noted.
 The specifications surrounded by are guaranteed by design engineering at $-40^{\circ}C \leq T_a \leq 105^{\circ}C$.

• RP132x001B/D (-JE) (Adjustable Output Voltage Type)
 $(-40^{\circ}C \leq T_a \leq 105^{\circ}C)$

| Symbol | Item | Conditions | | Min. | Typ. | Max. | Unit |
|---|--|--|---|-------|-------|--|-------------|
| V_{FB} | Feedback Voltage | $T_a = 25^{\circ}C$ | $V_{OUT} = V_{FB}$ | 0.785 | 0.800 | 0.815 | V |
| | | $-40^{\circ}C \leq T_a \leq 105^{\circ}C$ | | 0.771 | | 0.829 | |
| V_{OUT} | Output Voltage Adjusting Range | | | 0.8 | | 5.5 | V |
| I_{LIM} | Output Current Limit | $V_{OUT} = V_{FB}$ | | 1 | | | A |
| $\frac{\Delta V_{OUT}}{\Delta I_{OUT}}$ | Load Regulation | $0.1mA \leq I_{OUT} \leq 300mA$ | | | 3 | 20 | mV |
| | | $0.1mA \leq I_{OUT} \leq 1A$ | | | 5 | 60 | |
| V_{DIF} | Dropout Voltage | $V_{OUT} = V_{FB}$ | $I_{OUT} = 300mA$ | | 0.67 | 0.89 | V |
| | | | $I_{OUT} = 1A$ | | 1.20 | 1.54 | |
| I_{SS} | Supply Current | $V_{OUT} = V_{FB}$, $I_{OUT} = 0mA$ ($V_{IN} = 6.5V$) | | | 65 | 85 | μA |
| $I_{standby}$ | Standby Current | $V_{CE} = 0V$, $V_{IN} = 6.5V$ | $T_a = 25^{\circ}C$ | | 0.15 | 0.6 | μA |
| | | | $-40^{\circ}C \leq T_a \leq 105^{\circ}C$ | | | 4.0 | μA |
| $\frac{\Delta V_{OUT}}{\Delta V_{IN}}$ | Line Regulation | $V_{OUT} = V_{FB}$, $1.6V \leq V_{IN} \leq 6.5V$ | | | 0.05 | 0.10 | %/V |
| I_{SC} | Short Current Limit | $V_{OUT} = V_{FB} = 0V$ | | | 250 | | mA |
| I_{PD} | CE Pull-down Current | | | | 0.3 | 0.7 | μA |
| V_{CEH} | CE Input Voltage "H" | | | 1.0 | | | V |
| V_{CEL} | CE Input Voltage "L" | | | | | 0.4 | V |
| T_{TSD} | Thermal Shutdown Detection Temperature | Junction Temperature | | | 165 | | $^{\circ}C$ |
| T_{TSR} | Thermal Shutdown Released Temperature | Junction Temperature | | | 95 | | $^{\circ}C$ |
| R_{LOW} | Low Output Nch Tr. ON Resistance (D version) | $V_{IN} = 4.0V$, $V_{CE} = 0V$ | | | 50 | | Ω |

All test items listed under Electrical Characteristics are done except for Dropout Voltage and Load Regulation at 1A Output Current.

TYPICAL APPLICATION

Fixed Output Voltage Type (HSOP-6J/ SOT-89-5)

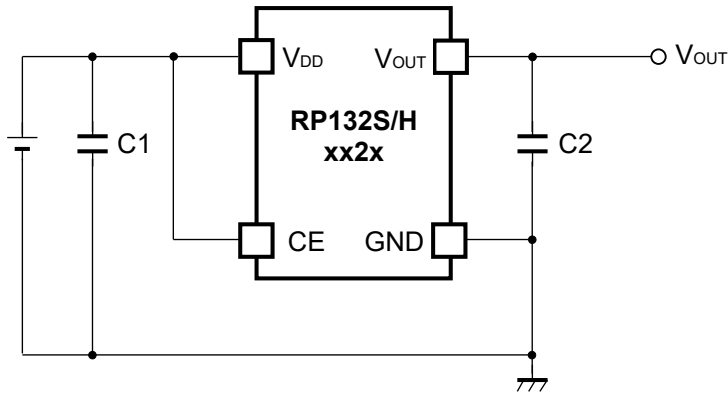

Fixed Output Voltage Type (TO-252-5-P2)

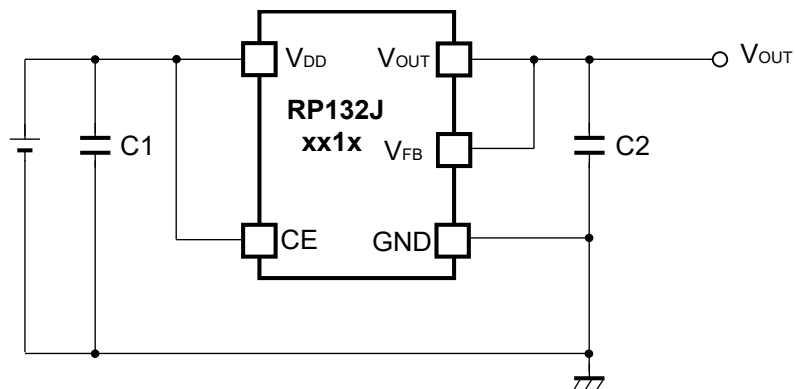

Adjustable Output Voltage Type (HSOP-6J / SOT-89-5/ TO-252-5-P2)

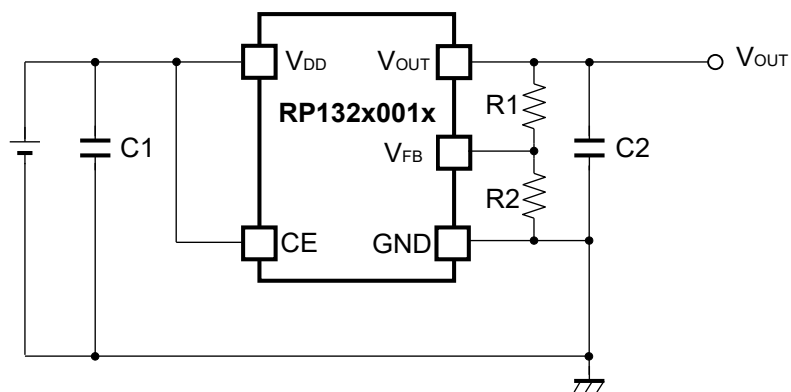

TECHNICAL NOTES

Phase Compensation

In these ICs, phase compensation is made for securing stable operation even if the load current is varied. For this purpose, use a capacitor C2 with good frequency characteristics and ESR (Equivalent Series Resistance).

If a tantalum capacitor is used, and its ESR of C2 is large, the loop oscillation may result. Because of this, select C2 carefully considering its frequency characteristics.

Recommended value of the external capacitors

| V_{OUT} | Capacitors | |
|---------------------|------------|-------------|
| $V_{SET} \leq 3.6V$ | C1 | 2.2 μ F |
| | C2 | 2.2 μ F |
| $V_{SET} > 3.6V$ | C1 | 2.2 μ F |
| | C2 | 4.7 μ F |

Please refer to "Technical Notes on Adjustable Output Voltage Type" when using R1 and R2 as output capacitors.

PCB Layout

Make V_{DD} and GND lines sufficient. If their impedance is high, noise pickup or unstable operation may result. Connect a capacitor C1 between V_{DD} and GND pin with a capacitance value as "Recommendation value of the external capacitors" above or more, and as close as possible to the pins.

Set external components, especially the output capacitor C2, as close as possible to the ICs, and make wiring as short as possible.

Transient Response

When using the Adjustable Output Voltage Type, the transient response could be affected by the external resistors. Evaluate the circuit taking the actual conditions of use into account.

TYPICAL APPLICATION FOR IC CHIP BREAKDOWN PREVENTION

Fixed Output Voltage Type (HSOP-6J / SOT-89-5)

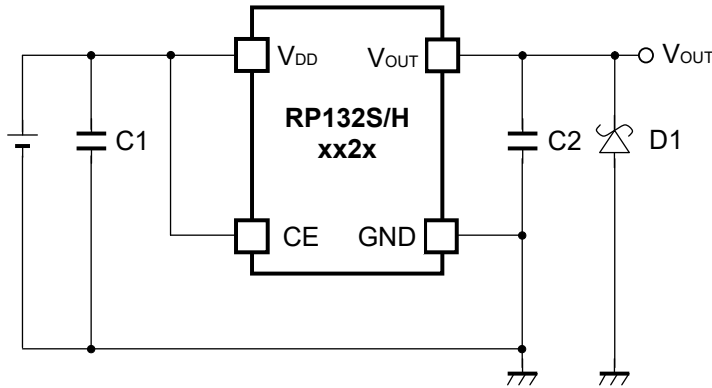

Fixed Output Voltage Type (TO-252-5-P2)

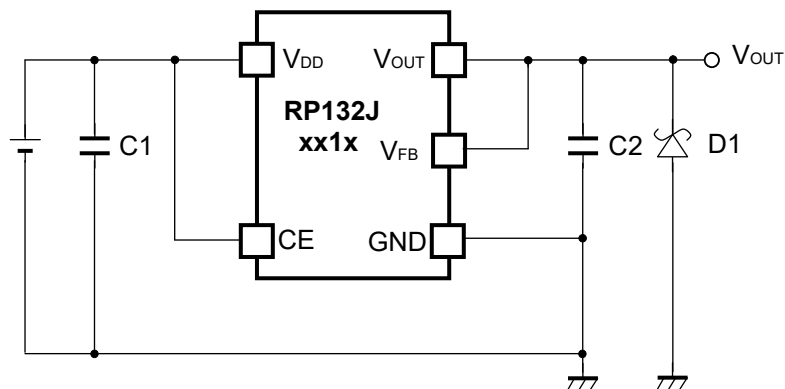

Adjustable Output Voltage Type (HSOP-6J / SOT-89-5/ TO-252-5-P2)

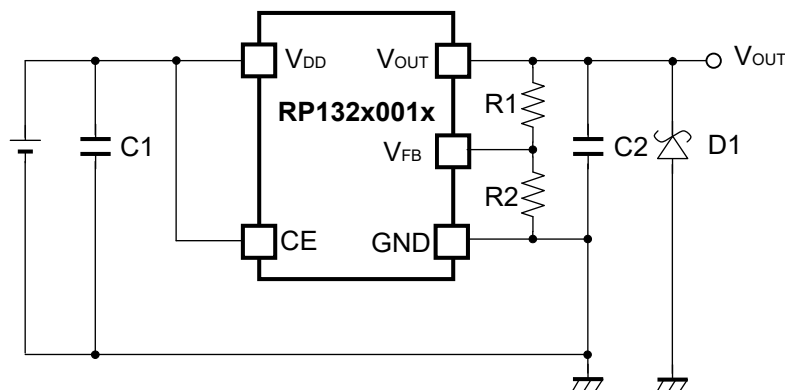

When a sudden surge of electrical current travels along the V_{OUT} pin and GND due to a short-circuit, electrical resonance of a circuit involving an output capacitor ($C2$) and a short circuit inductor generates a negative voltage and may damage the device or the load devices. Connecting a schottky diode ($D1$) between the V_{OUT} pin and GND has the effect of preventing damage to them.

ADJUSTABLE OUTPUT VOLTAGE TYPE SETTINGS

Output Voltage Setting Method

Adjustable Output Voltage Type can be adjusted the output voltage up to 5.5V by using the external divider resistors. Also, please use 16kΩ or less for R2 resistor.

If the V_{FB} voltage is described as setV_{FB}, the output voltage can be set by using the following equations

SetV_{FB} is equal to 0.8V. The V_{OUT} pin of Adjustable Output Voltage Type should be connected to the V_{FB} pin.

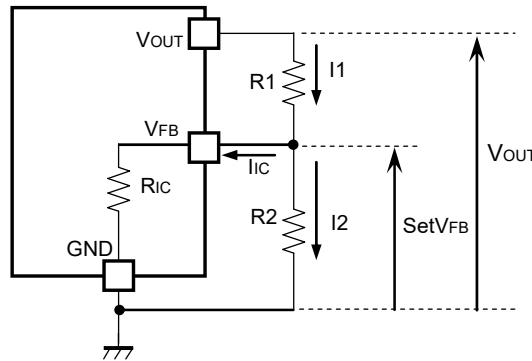

$$I1 = I_{IC} + I2 \dots\dots\dots (1)$$

$$I2 = \text{set}V_{FB} / R2 \dots\dots\dots (2)$$

Thus,

$$I1 = I_{IC} + \text{set}V_{FB} / R2 \dots\dots\dots (3)$$

Therefore,

$$V_{OUT} = \text{set}V_{FB} \times R1 \times I1 \dots\dots\dots (4)$$

Put Equation (3) into Equation (4), then

$$\begin{aligned} V_{OUT} &= \text{set}V_{FB} + R1 (I_{IC} + \text{set}V_{FB} / R2) \\ &= \text{set}V_{FB} \times (1 + R1 / R2) + R1 \times I_{IC} \dots\dots\dots (5) \end{aligned}$$

In Equation (5), R1x I_{IC} is the error-causing factor in V_{OUT}.

As for I_{IC},

$$I_{IC} = \text{set}V_{FB} / R_{1C} \dots\dots\dots (6)$$

Therefore, the error-causing factor R1x I_{IC} can be described as follows.

$$\begin{aligned} R1 \times I_{IC} &= R1 \times \text{set}V_{FB} / R_{1C} \\ &= \text{set}V_{FB} \times R1 / R_{1C} \dots\dots\dots (7) \end{aligned}$$

For better accuracy, choosing R1 (<<R_{1C}) reduces this error.

Without the error-causing factor R1x I_{IC}, the output voltage can be calculated by the following equation

$$V_{OUT} = \text{set}V_{FB} \times ((R1 + R2) / R2) \dots\dots\dots (8)$$

R_{1C} of RP132x is approximately Typ.1.3MΩ (T_a=25°C, this value is guaranteed by design).

The value could be affected by the temperature, therefore evaluate the circuit taking the actual conditions of use into account.

INRUSH CURRENT LIMIT TIME SETTINGS

The RP132x Series include the circuit which can limit the inrush current at start-up to 500mA or less. The current limit time of B/D version is fixed internally as approximately Typ.500 μ s.

Please note that during the inrush current limit time, the load current cannot be more than the limited current.

PACKAGE INFORMATION

POWER DISSIPATION (SOT-89-5)

The power dissipation of the package is dependent on PCB material, layout, and environmental conditions. The following measurement conditions are based on JEDEC STD. 51-7.

Measurement Conditions

| Item | Measurement Conditions |
|------------------|--|
| Environment | Mounting on Board (Wind Velocity = 0 m/s) |
| Board Material | Glass Cloth Epoxy Plastic (Four-Layer Board) |
| Board Dimensions | 76.2 mm × 114.3 mm × 0.8 mm |
| Copper Ratio | Outer Layer (First Layer): Less than 95% of 50 mm Square Inner Layers (Second and Third Layers): Approx. 100% of 50 mm Square Outer Layer (Fourth Layer): Approx. 100% of 50 mm Square |
| Through-holes | φ 0.3 mm × 13 pcs |

Measurement Result

(Ta = 25°C, Tjmax = 150°C)

| Item | Measurement Result |
|--|--------------------|
| Power Dissipation | 3200 mW |
| Thermal Resistance (θja) | θja = 38°C/W |
| Thermal Characterization Parameter (ψjt) | ψjt = 13°C/W |

θja: Junction-to-Ambient Thermal Resistance

ψjt: Junction-to-Top Thermal Characterization Parameter

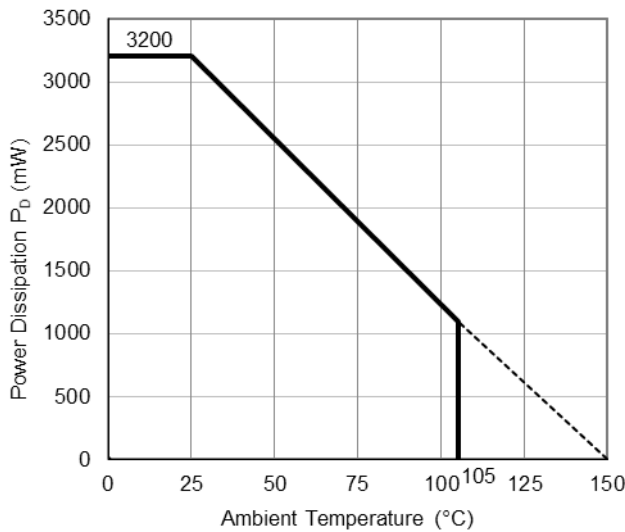

Power Dissipation vs. Ambient Temperature

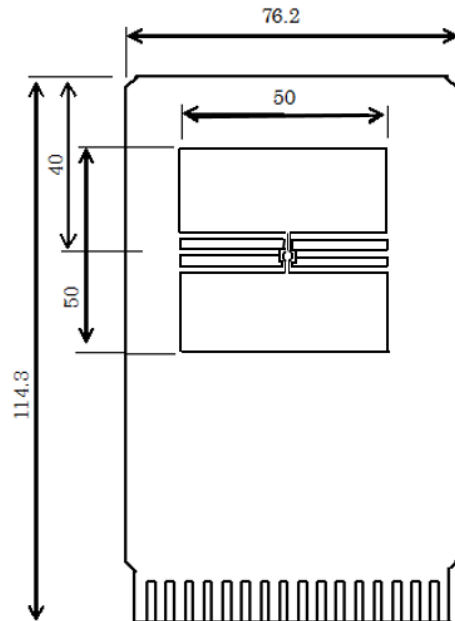

Measurement Board Pattern

PACKAGE DIMENSIONS (SOT-89-5)

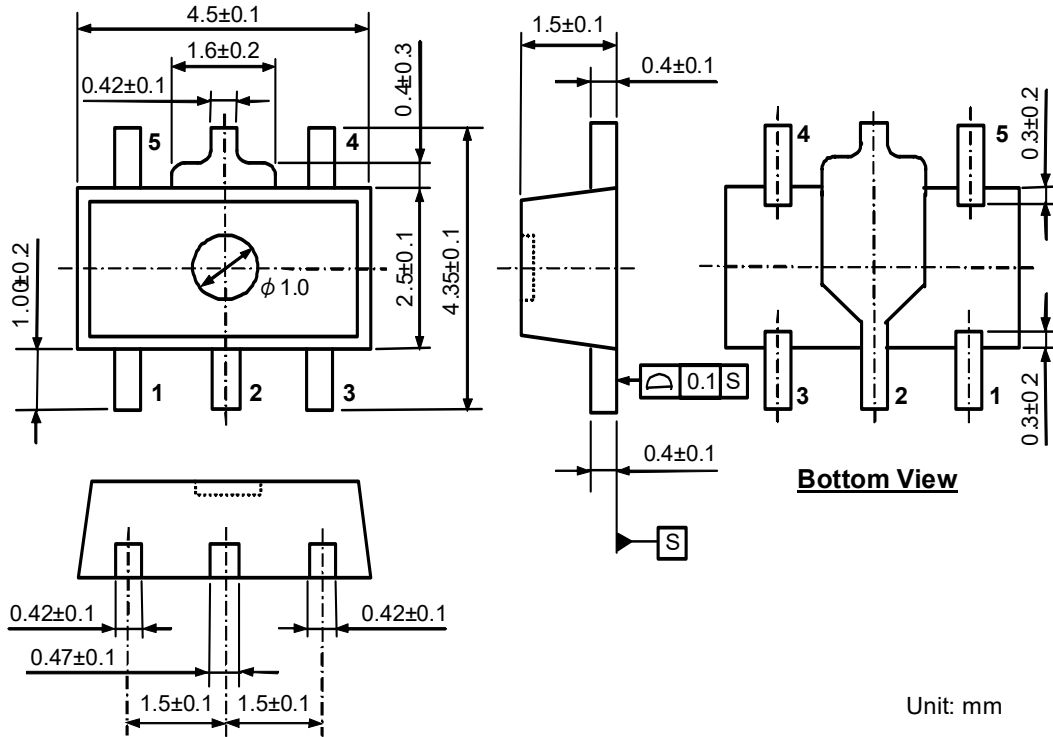

Bottom View

Unit: mm

SOT-89-5 Package Dimensions

RP132x

NO.EC-265-190408

POWER DISSIPATION (HSOP-6J)

The power dissipation of the package is dependent on PCB material, layout, and environmental conditions. The following measurement conditions are based on JEDEC STD. 51-7.

Measurement Conditions

| Item | Measurement Conditions |
|------------------|--|
| Environment | Mounting on Board (Wind Velocity = 0 m/s) |
| Board Material | Glass Cloth Epoxy Plastic (Four-Layer Board) |
| Board Dimensions | 76.2 mm × 114.3 mm × 0.8 mm |
| Copper Ratio | Outer Layer (First Layer): Less than 95% of 50 mm Square Inner Layers (Second and Third Layers): Approx. 100% of 50 mm Square Outer Layer (Fourth Layer): Approx. 100% of 50 mm Square |
| Through-holes | φ 0.3 mm × 28 pcs |

Measurement Result

(Ta = 25°C, Tjmax = 150°C)

| Item | Measurement Result |
|--|--------------------|
| Power Dissipation | 3400 mW |
| Thermal Resistance (θja) | θja = 37°C/W |
| Thermal Characterization Parameter (ψjt) | ψjt = 7°C/W |

θja: Junction-to-Ambient Thermal Resistance

ψjt: Junction-to-Top Thermal Characterization Parameter

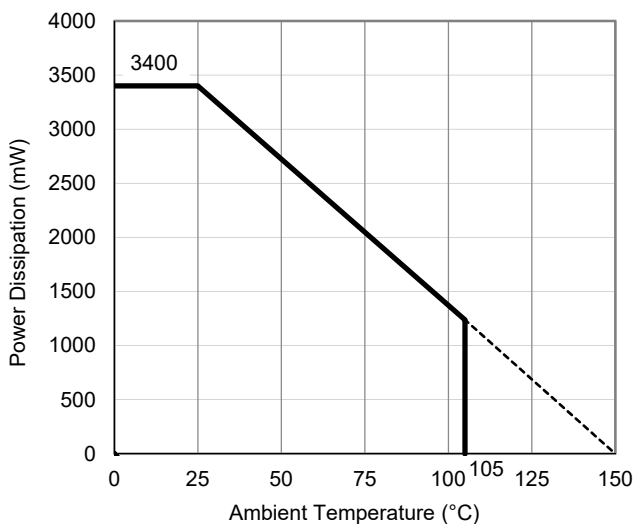

Power Dissipation vs. Ambient Temperature

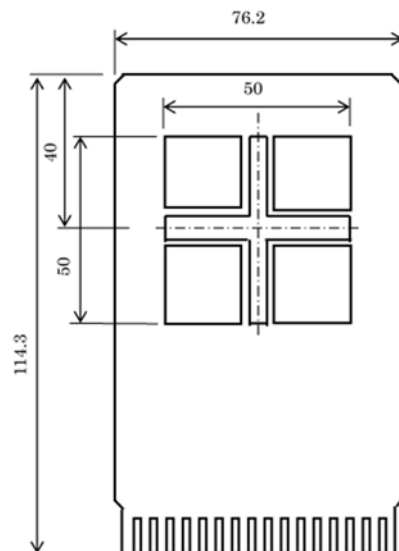

Measurement Board Pattern

PACKAGE DIMENSIONS (HSOP-6J)

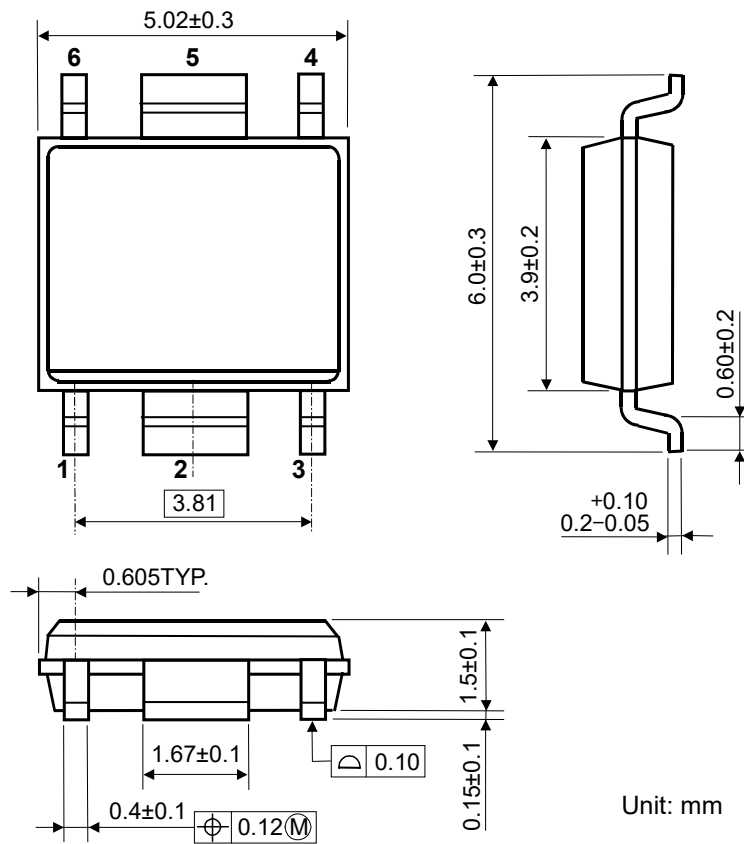

Unit: mm

HSOP-6J Package Dimensions

RP132x

NO.EC-265-190408

POWER DISSIPATION (TO-252-5-P2)

The power dissipation of the package is dependent on PCB material, layout, and environmental conditions. The following measurement conditions are based on JEDEC STD. 51-7.

Measurement Conditions

| Item | Measurement Conditions |
|------------------|--|
| Environment | Mounting on Board (Wind Velocity = 0 m/s) |
| Board Material | Glass Cloth Epoxy Plastic (Four-Layer Board) |
| Board Dimensions | 76.2 mm × 114.3 mm × 0.8 mm |
| Copper Ratio | Outer Layer (First Layer): Less than 95% of 50 mm Square Inner Layers (Second and Third Layers): Approx. 100% of 50 mm Square Outer Layer (Fourth Layer): Approx. 100% of 50 mm Square |
| Through-holes | φ 0.3 mm × 21 pcs |

Measurement Result

(Ta = 25°C, Tjmax = 150°C)

| Item | Measurement Result |
|--|--------------------|
| Power Dissipation | 4800 mW |
| Thermal Resistance (θja) | θja = 26°C/W |
| Thermal Characterization Parameter (ψjt) | ψjt = 7°C/W |

θja: Junction-to-Ambient Thermal Resistance

ψjt: Junction-to-Top Thermal Characterization Parameter

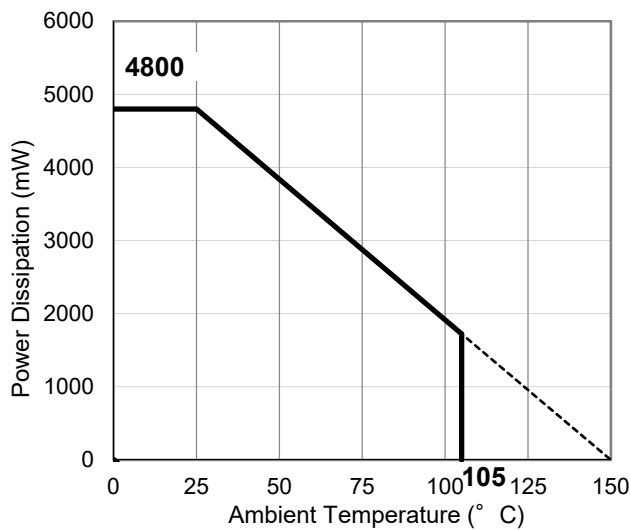

Power Dissipation vs. Ambient Temperature

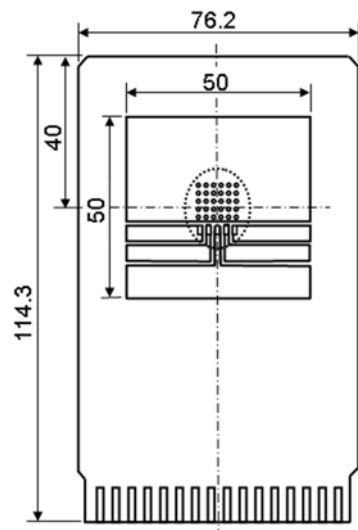

Measurement Board Pattern

PACKAGE DIMENSIONS (TO-252-5-P2)

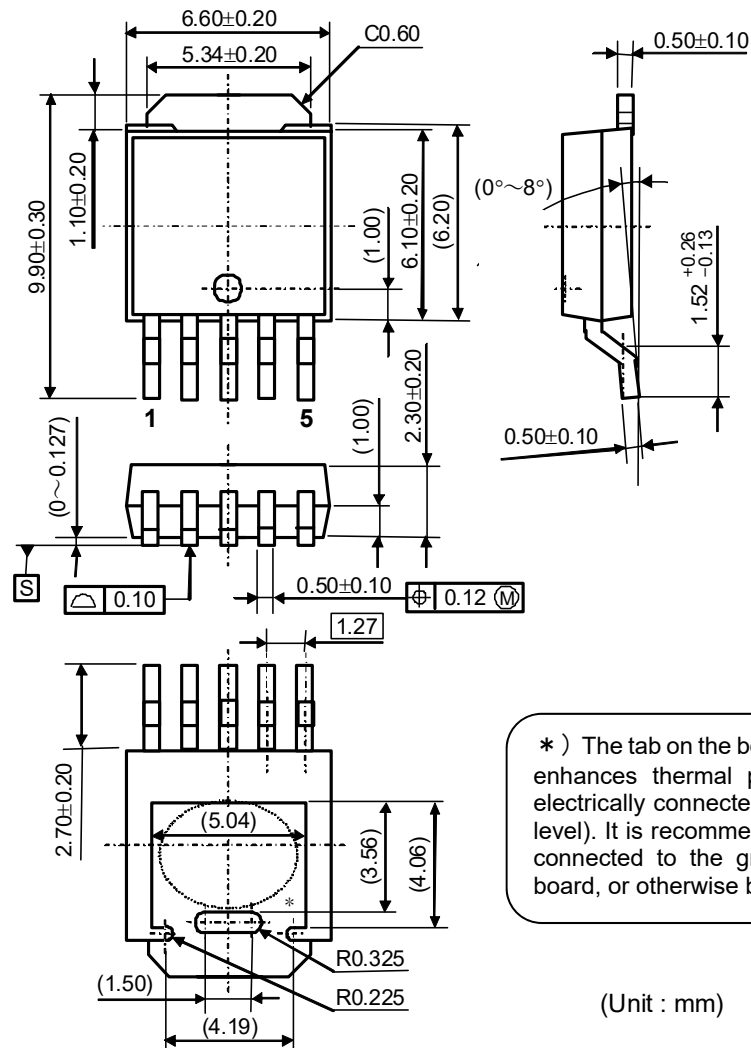

*) The tab on the bottom of the package enhances thermal performance and is electrically connected to GND (substrate level). It is recommended that the tab be connected to the ground plane on the board, or otherwise be left floating.

(Unit : mm)

TYPICAL CHARACTERISTICS

Note: Typical Characteristics are intended to be used as reference data; they are not guaranteed.

1) Output Voltage vs. Input Voltage (Ta=25°C)

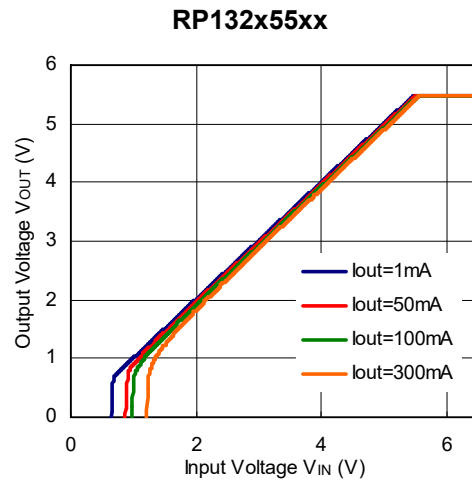
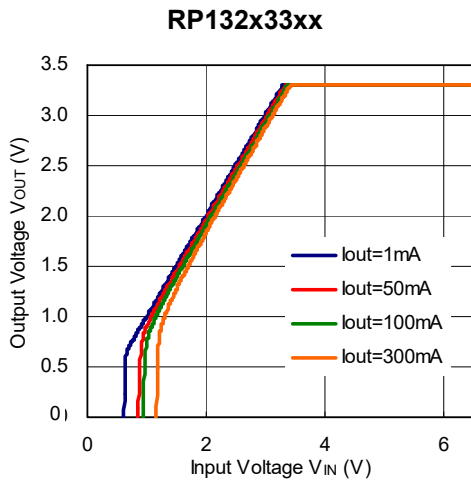
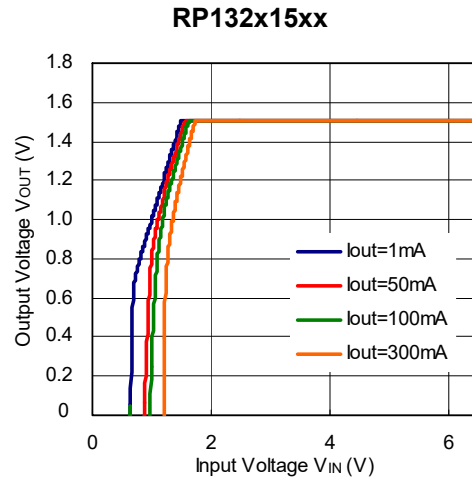
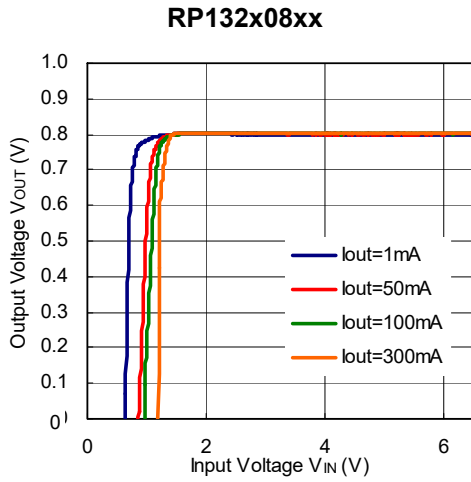

2) Supply Current vs. Input Voltage (Ta=25°C)

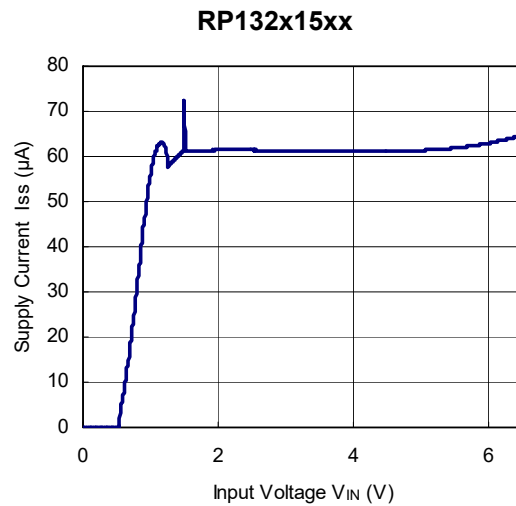
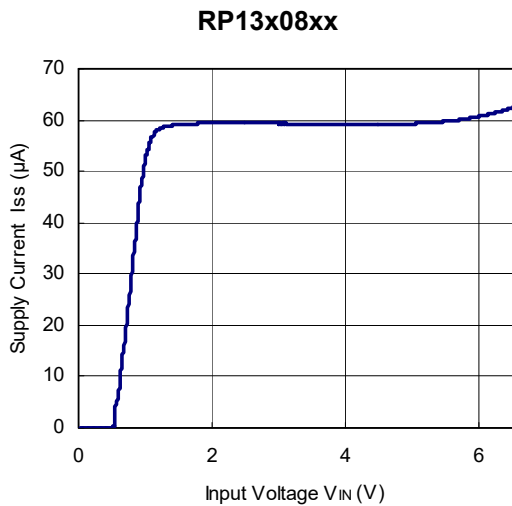

RP132x33xx

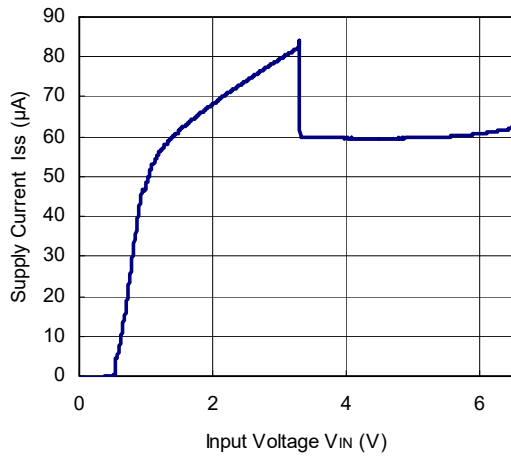

RP132x55xx

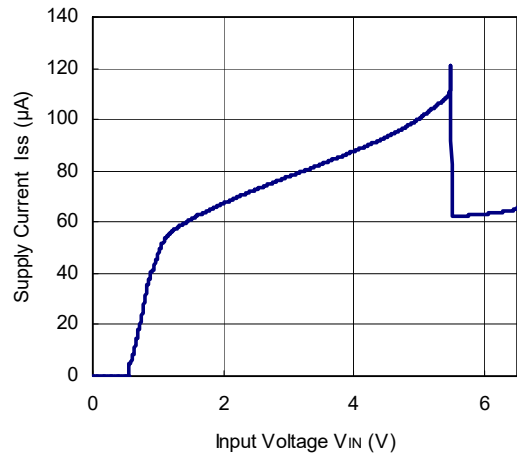

3) Supply Current vs. Temperature

RP132x08xx

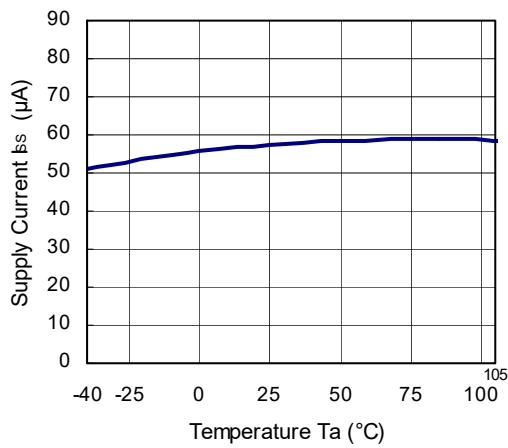

RP132x15xx

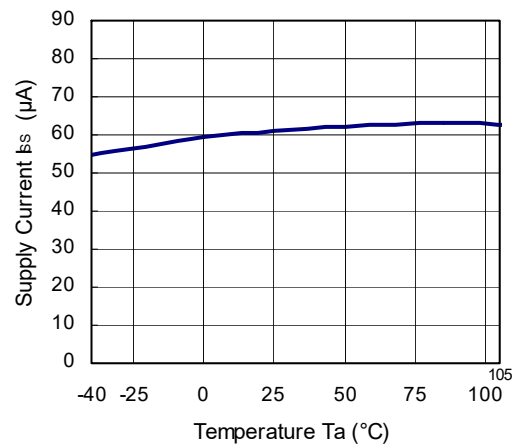

RP132x33xx

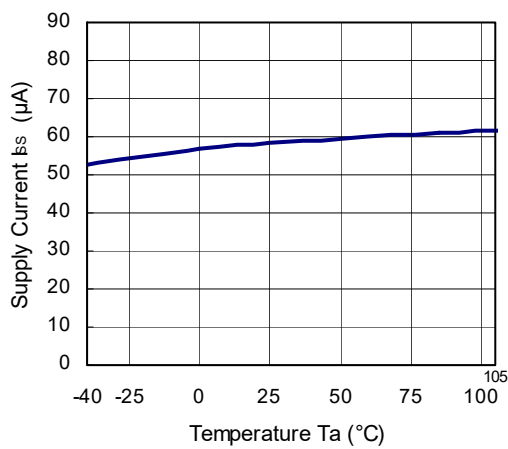

RP132x55xx

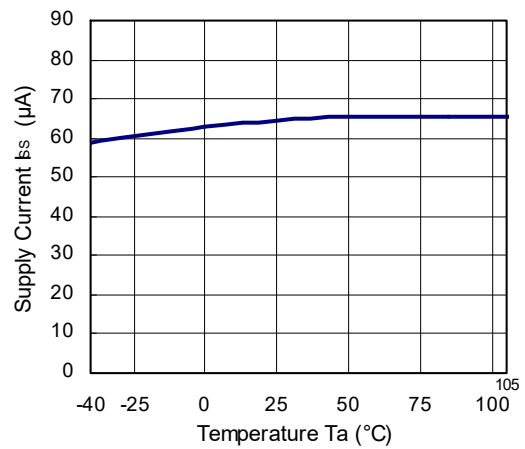

4) Output Voltage vs. Temperature

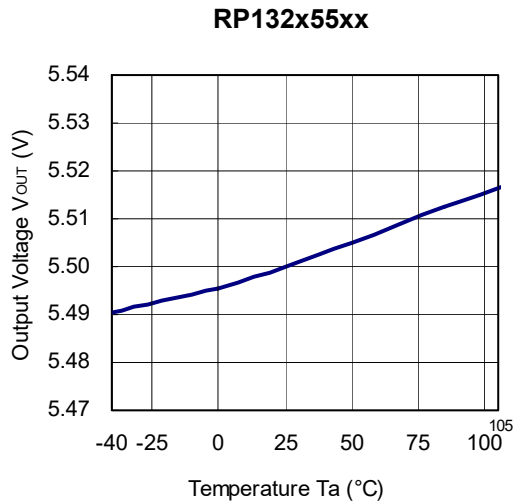
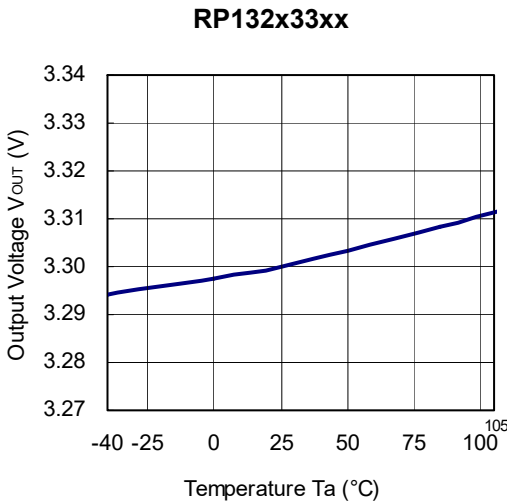
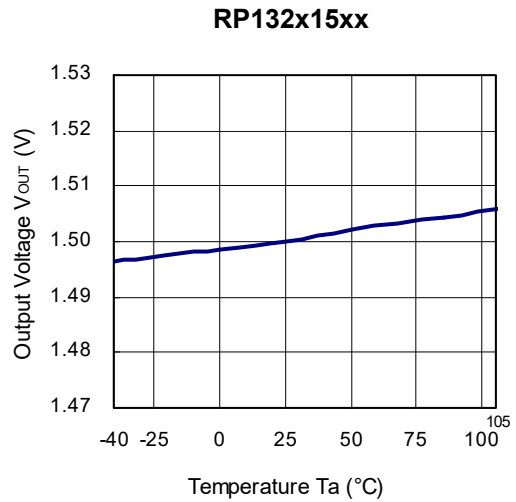
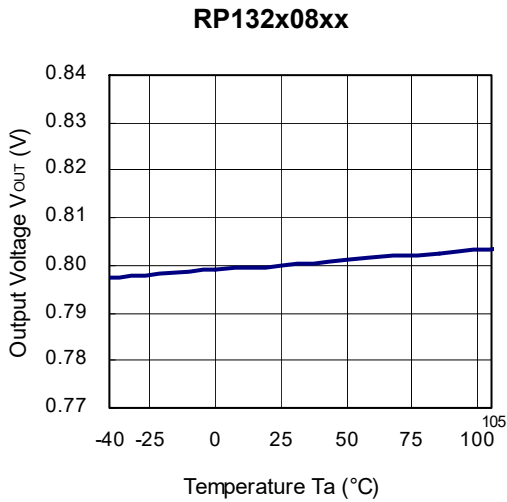

5) Dropout Voltage vs. Output Current

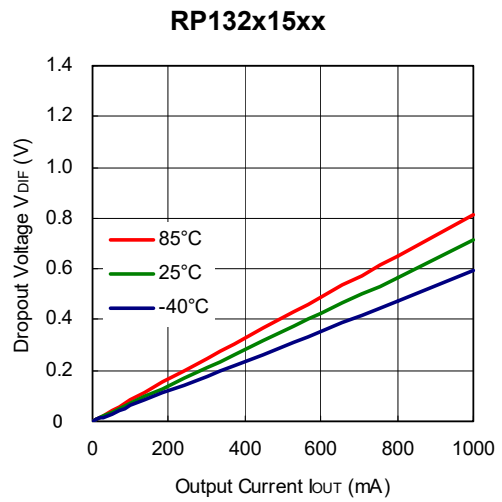
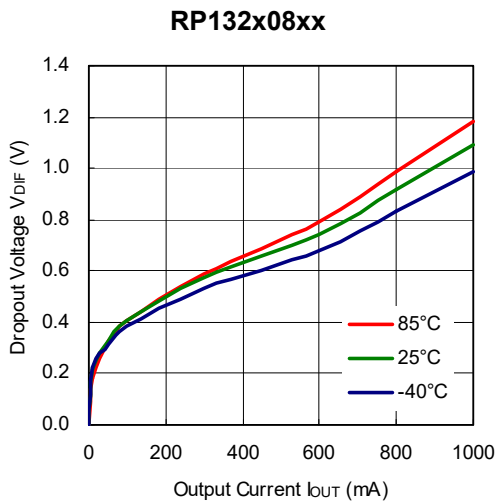

RP132x33xx

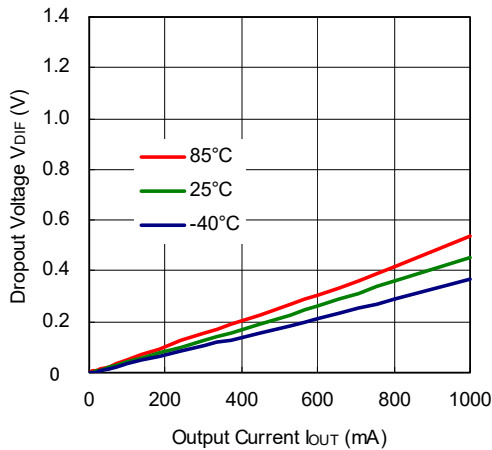

RP132x55xx

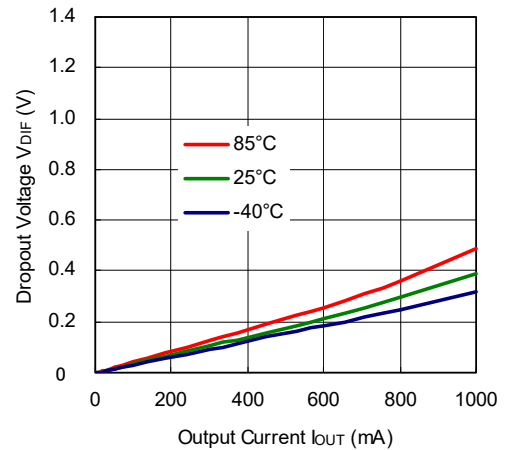

6) Dropout Voltage vs. Set Output Voltage

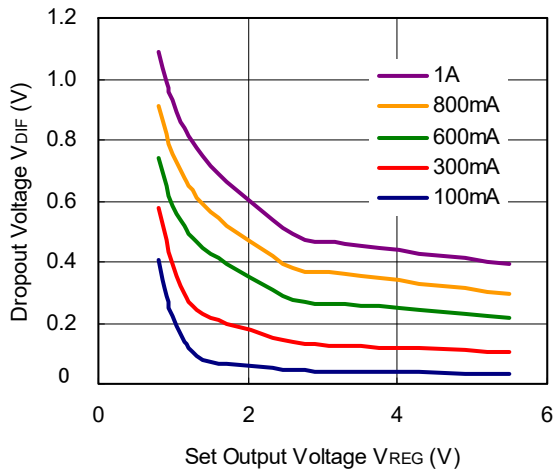

7) Ripple Rejection vs. Input Voltage (C1=none, Ripple=0.2Vp-p, Ta=25°C)

RP132x33xx

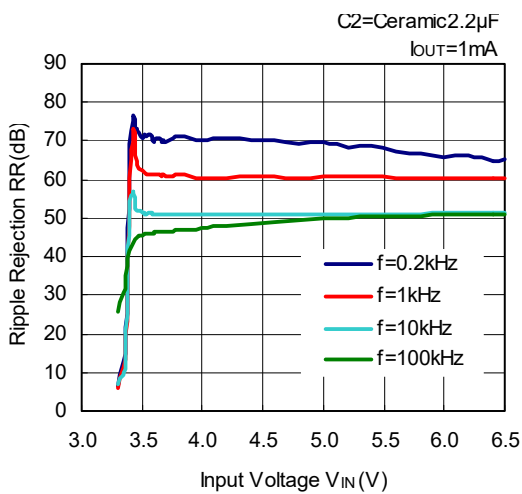

RP132x33xx

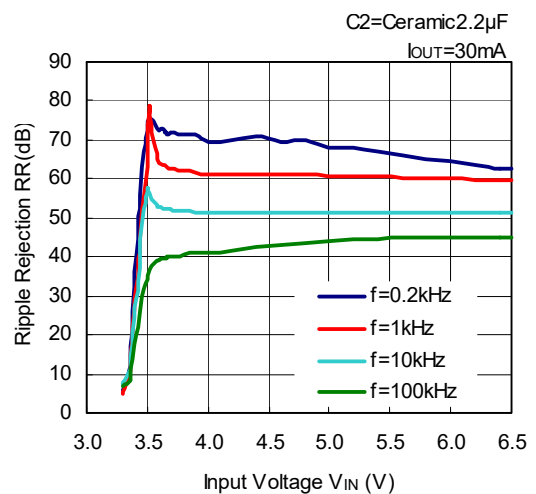

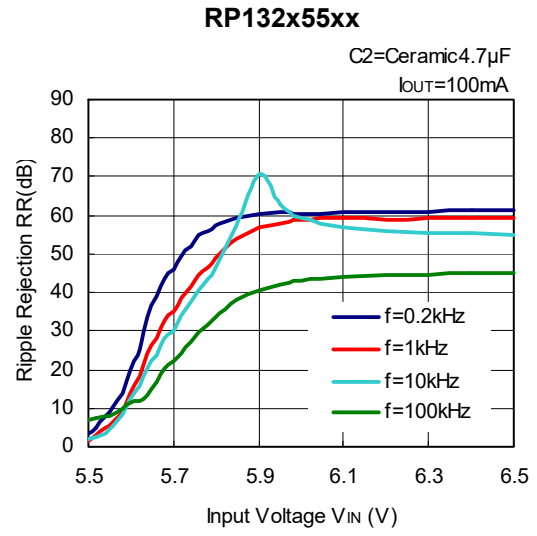
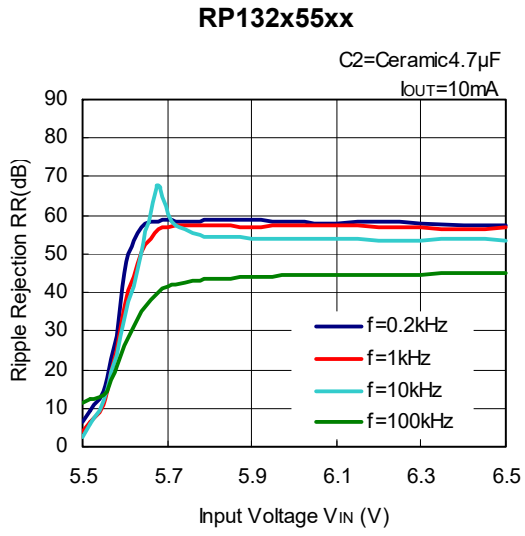
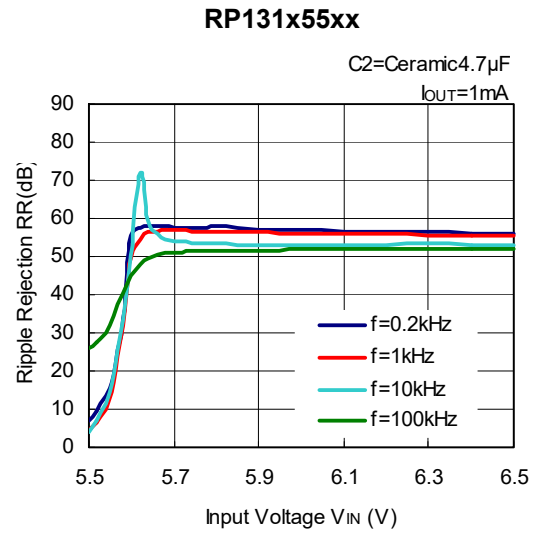
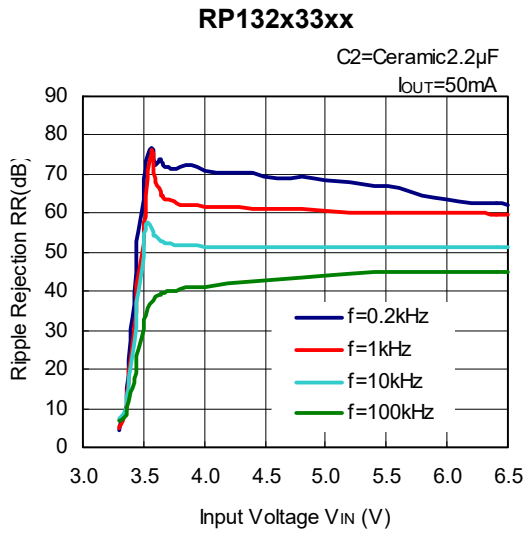

8) Ripple Rejection vs. Frequency (C1=none, Ta=25°C)

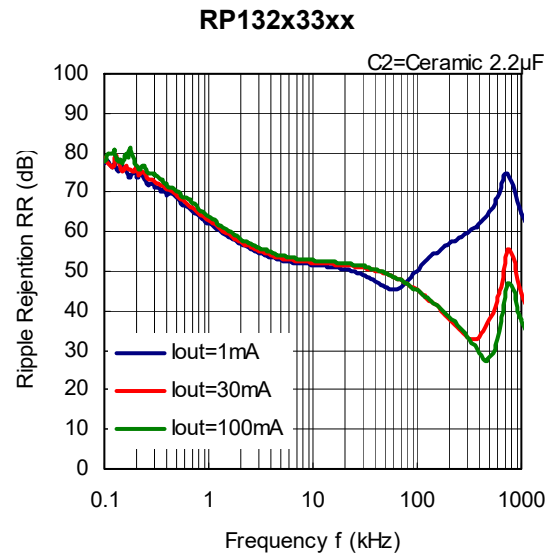
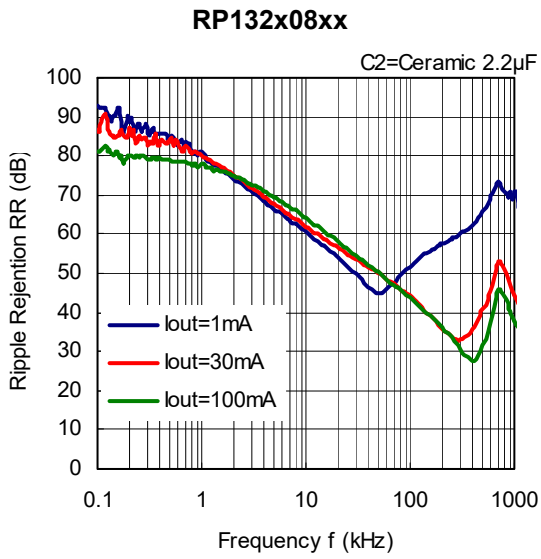

RP132x551x

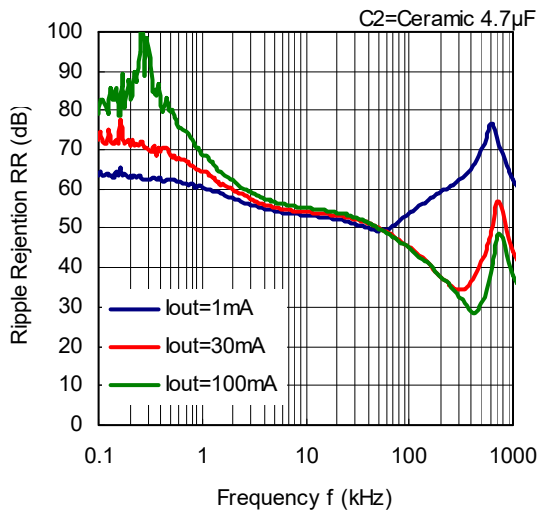

9) Input Transient Response (C1=none, Iout=100mA, tr=tf=5 μ s, Ta=25 $^{\circ}$ C)

RP132x08xx

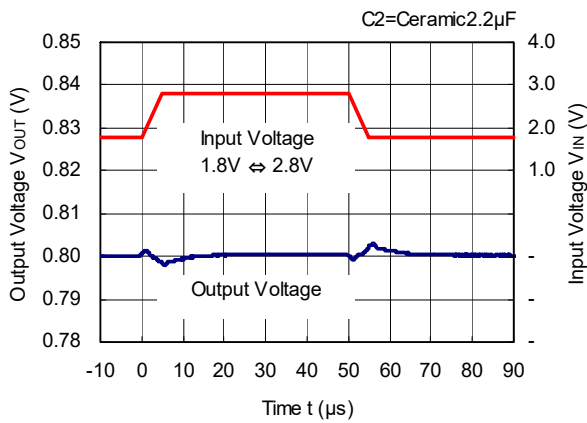

RP132x33xx

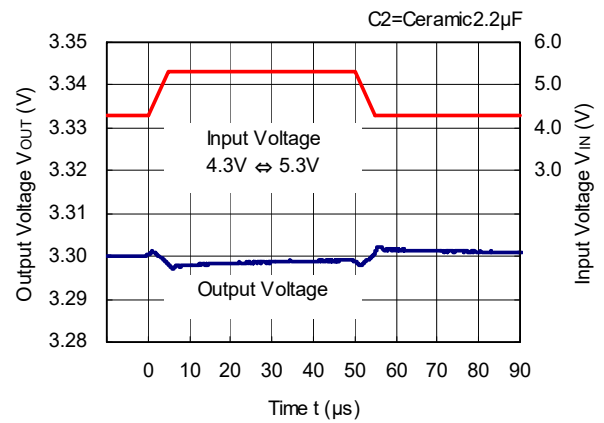

RP132x55xx

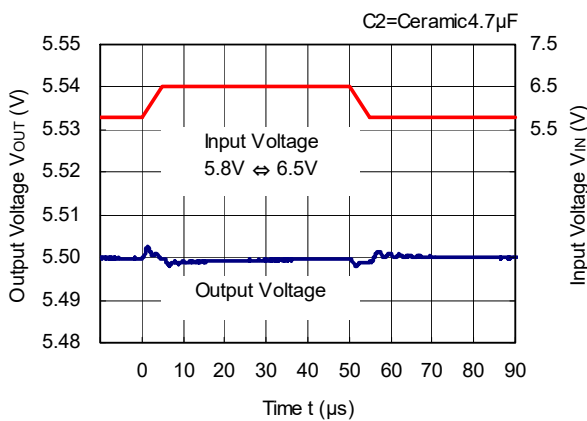

10) Load Transient Response ($V_{IN}=V_{OUT}+1.0V$, $C1=Ceramic\ 2.2\mu F$, $t_r=t_f=0.5\mu s$, $T_a=25^\circ C$)

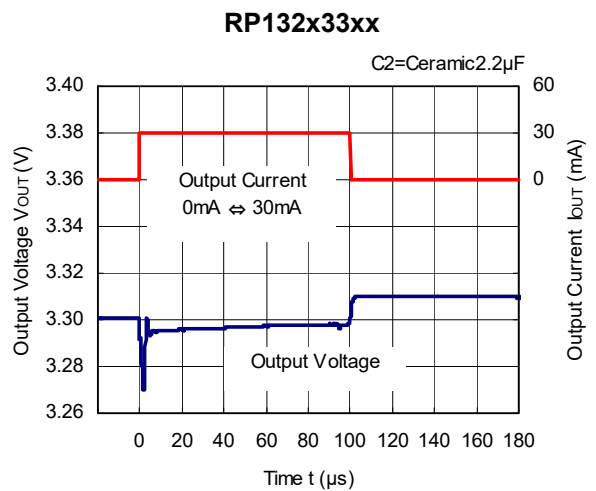
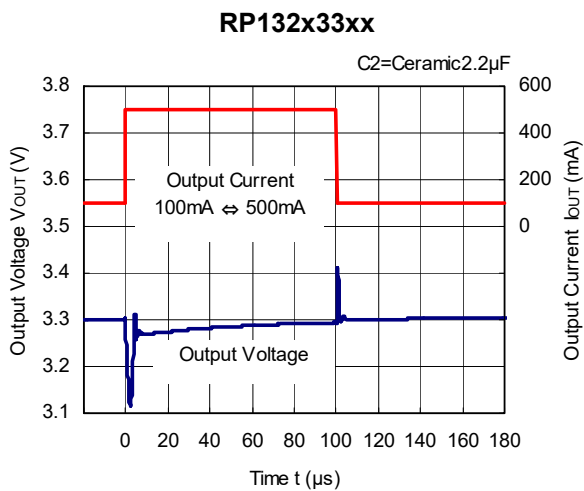
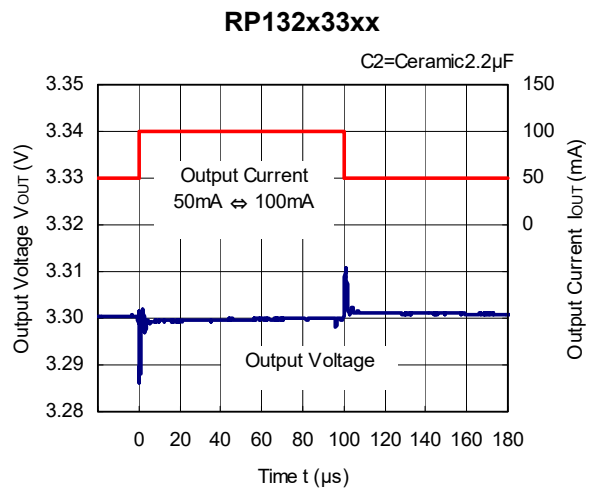
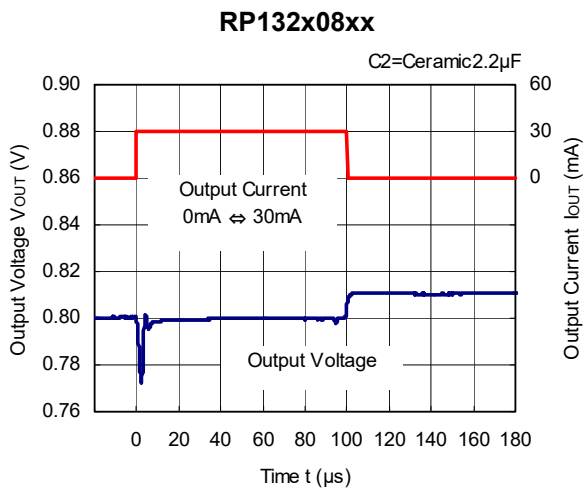
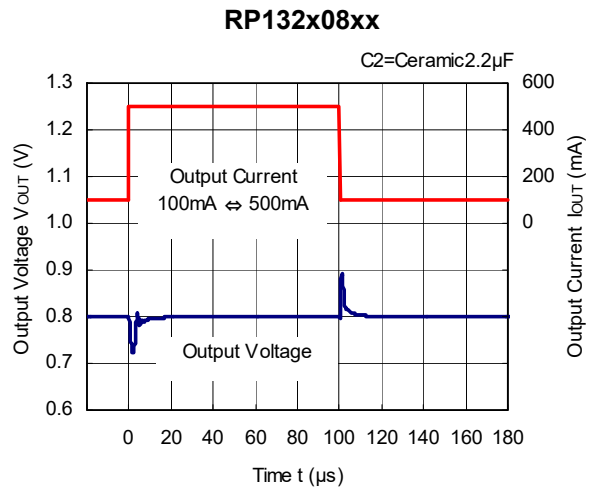
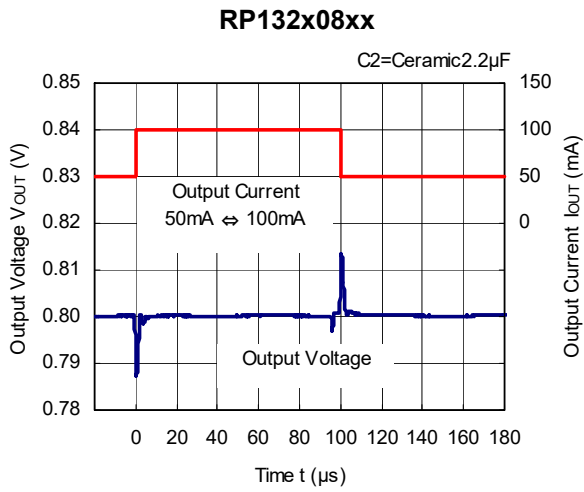

RP132x55xx

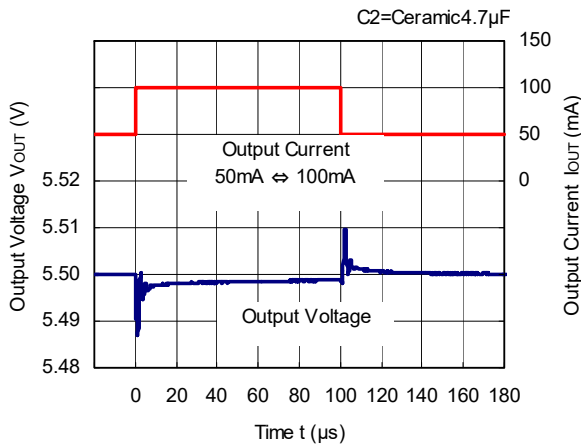

RP132x55xx

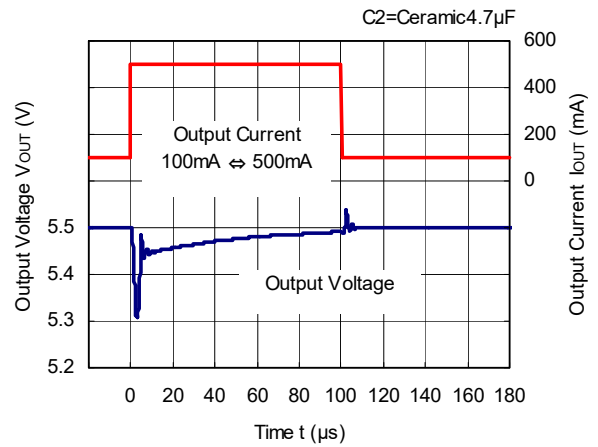

RP132x55xx

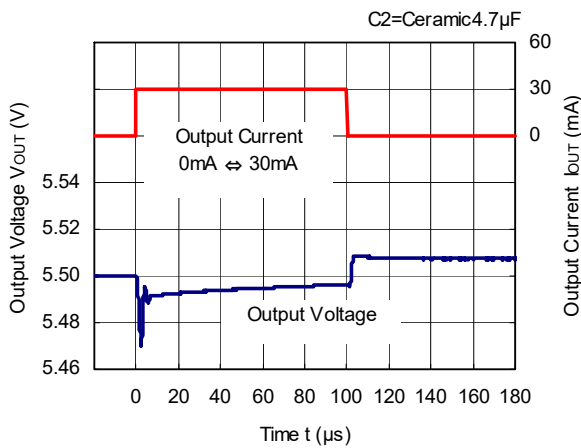

11) Turn on Speed with CE pin (C1=Ceramic 2.2μF, Ta=25°C)

RP132x08xx

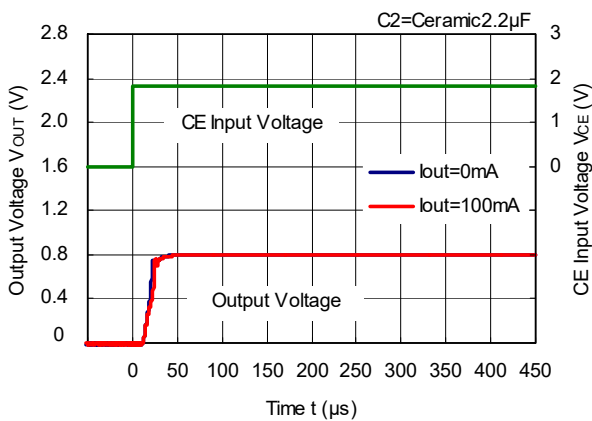

RP132x33xx

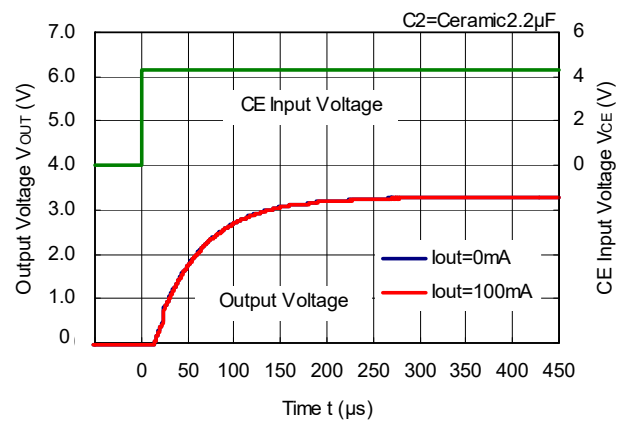

RP132x55xx

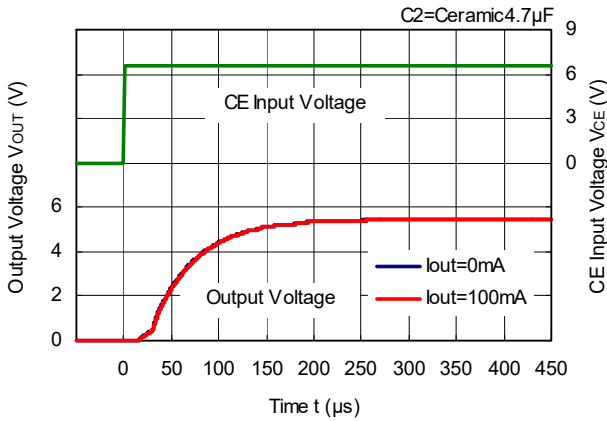

12) Turn off Speed with CE pin (D version) (C1=Ceramic 2.2 μ F, Ta=25°C)

RP132x08xD

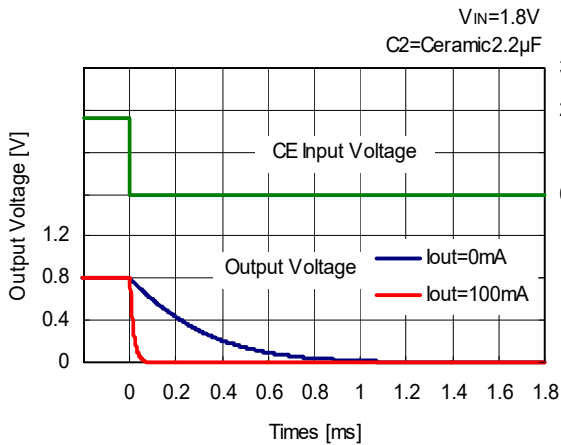

RP132x33xD

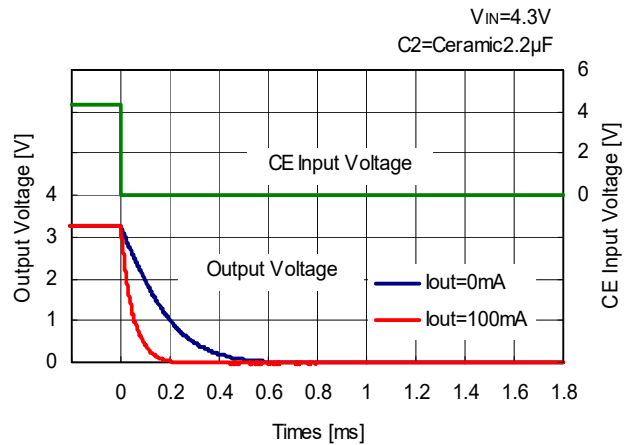

RP132x55xD

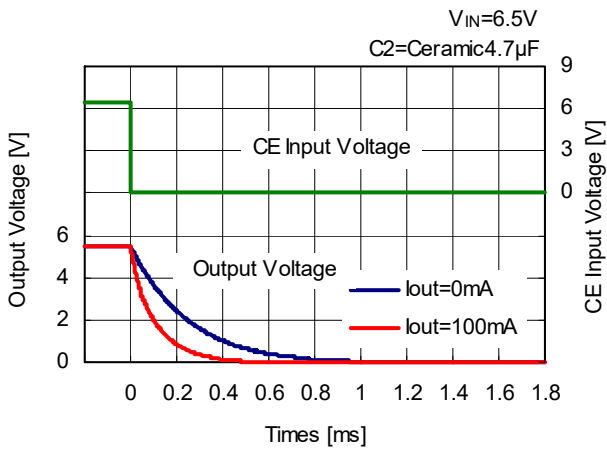

13) Inrush Current (C1=Ceramic 2.2μF, I_{OUT}=100mA, Ta=25°C)

RP132x08xx

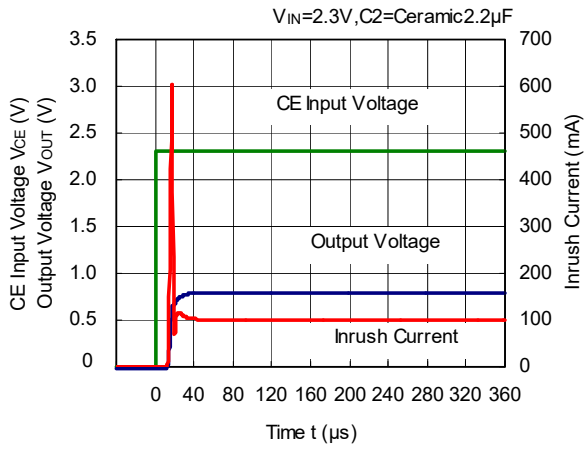

RP132x33xx

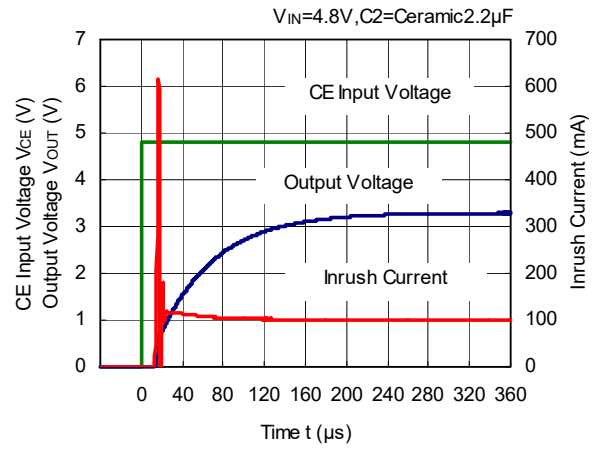

RP132x55xx

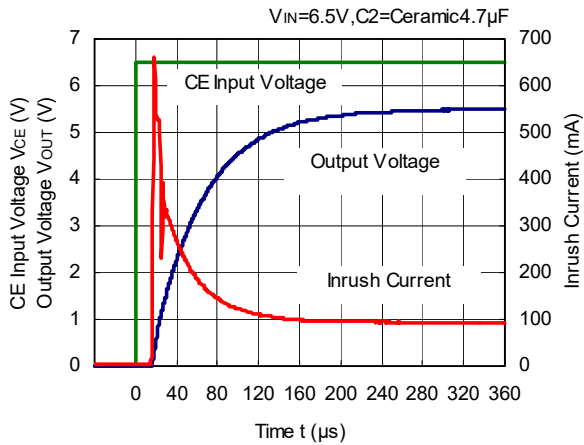

14) Minimum Operating Voltage

RP132x08xx

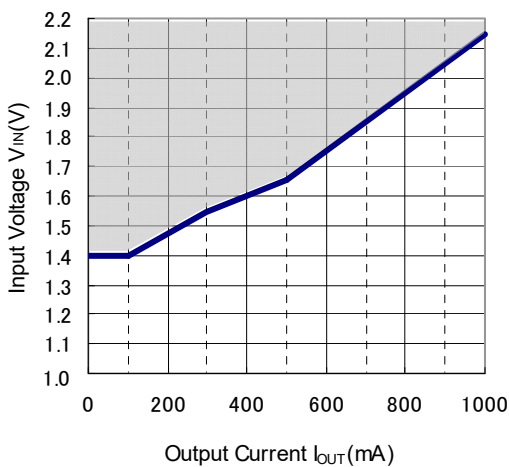

The operation rage that can output 0.8V is shown by the hatched area in the graph.

ESR vs. Output Current

When using these ICs, consider the following points:

The relations between I_{OUT} (Output Current) and ESR of an output capacitor are shown below.

The conditions when the white noise level is under $40\mu V$ (Avg.) are marked as the hatched area in the graph.

Measurement Conditions

Frequency Band : 10Hz to 2MHz

Temperature : $-40^{\circ}C$ to $85^{\circ}C$

Hatched Area : Noise level is under $40\mu V_{ms}$ (Avg.)

C1 : $2.2\mu F$ (Kyocera CM05X5R225M06A)

C2 : $2.2\mu F$ ($V_{OUT} = 0.8V$, Kyocera CM105X5R225K06AB)
 $4.7\mu F$ ($V_{OUT} = 5.5V$, Kyocera CM105X5R475M06AB)

RP132x08xx

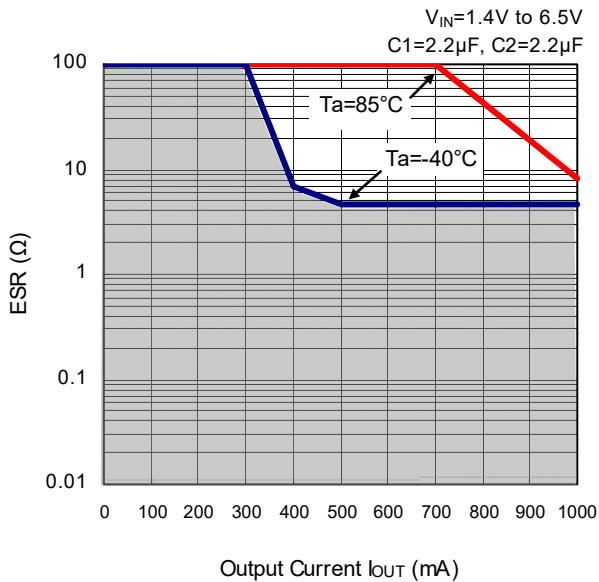

RP132x55xx

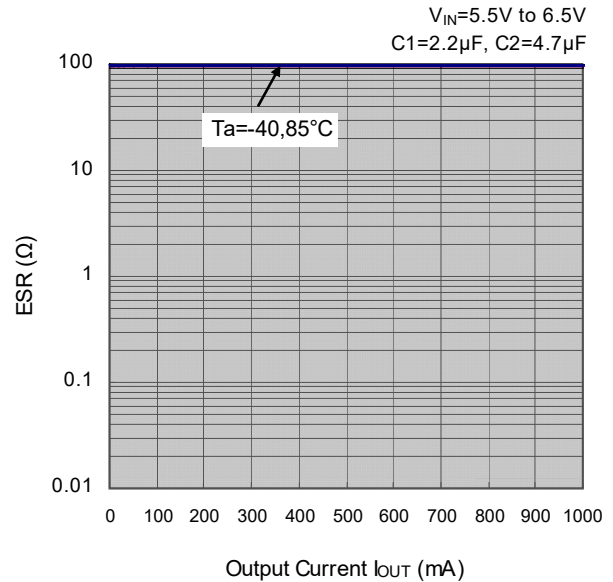



1. The products and the product specifications described in this document are subject to change or discontinuation of production without notice for reasons such as improvement. Therefore, before deciding to use the products, please refer to our sales representatives for the latest information thereon.
2. The materials in this document may not be copied or otherwise reproduced in whole or in part without prior written consent of our company.
3. Please be sure to take any necessary formalities under relevant laws or regulations before exporting or otherwise taking out of your country the products or the technical information described herein.
4. The technical information described in this document shows typical characteristics of and example application circuits for the products. The release of such information is not to be construed as a warranty of or a grant of license under our company's or any third party's intellectual property rights or any other rights.
5. The products in this document are designed for automotive applications. However, when using the products for automotive applications, please make sure to contact our sales representative in advance due to confirming the quality level.
6. We are making our continuous effort to improve the quality and reliability of our products, but semiconductor products are likely to fail with certain probability. In order to prevent any injury to persons or damages to property resulting from such failure, customers should be careful enough to incorporate safety measures in their design, such as redundancy feature, fire containment feature and fail-safe feature. We do not assume any liability or responsibility for any loss or damage arising from misuse or inappropriate use of the products.
7. Anti-radiation design is not implemented in the products described in this document.
8. The X-ray exposure can influence functions and characteristics of the products. Confirm the product functions and characteristics in the evaluation stage.
9. WLCSP products should be used in light shielded environments. The light exposure can influence functions and characteristics of the products under operation or storage.
10. There can be variation in the marking when different AOI (Automated Optical Inspection) equipment is used. In the case of recognizing the marking characteristic with AOI, please contact our sales or our distributor before attempting to use AOI.
11. Please contact our sales representatives should you have any questions or comments concerning the products or the technical information.



Nisshinbo Micro Devices Inc.

Official website

<https://www.nisshinbo-microdevices.co.jp/en/>

Purchase information

<https://www.nisshinbo-microdevices.co.jp/en/buy/>

