

Low On Resistance/ Low Voltage 1 Ch 500 mA/ 1.0 A Alternative LDO for Automotive Applications

No. EC-390-221115

OUTLINE

The RP115x is a positive voltage regulator featuring 500 mA/ 1.0 A that provide high ripple rejection, low dropout voltage, high output voltage accuracy, and low supply current. Internally, the RP115x consists of a voltage reference unit, an error amplifier, a resistor-net for output voltage setting, a current limit circuit, a thermal shutdown circuit, and a reverse current protection circuit. The RP115x uses CMOS process for achieving low supply current, low On Resistance for low dropout voltage (Typ. 0.195 V (DFN2020-8B, $I_{OUT} = 1.0$ A, $V_{SET} = 1.2$ V)) and CE function for long battery life.

The RP115x is available in the DFN2020-8B package for space saving and the SOT-89-5 (Output current: 1.0 A fixed) package for higher power applications. The RP115L (DFN2020-8B package) can choose the output current limit between 1.0 A or 500 mA by alternating the LCON pin between “High” or “Low”.

The RP115H (SOT-89-5 package) can output only 1.0 A since it does not include the LCON pin.

FEATURES

- Input Voltage Range (Maximum Rating) 1.4 V to 5.25 V (6.0 V)
- Operating Temperature -40°C to 105°C
- Supply Current Typ. 110 μA
- Standby Current Typ. 0.5 μA
- Dropout Voltage Typ. 0.195 V (RP115L: $I_{OUT} = 1.0$ A, $V_{SET} = 1.2$ V)
Typ. 0.235 V (RP115H: $I_{OUT} = 1.0$ A, $V_{SET} = 1.2$ V)
- Ripple Rejection Typ. 80 dB ($f = 1$ kHz, $V_{SET} \leq 1.8$ V)
Typ. 75 dB ($f = 1$ kHz, $V_{SET} > 1.8$ V)
- Output Voltage Accuracy $\pm 1.0\%$ ($V_{SET} \geq 1.75$ V)
- Output Voltage Temperature Coefficient Typ. ± 30 ppm/ $^{\circ}\text{C}$ ($V_{SET} \geq 1.75$ V)
Typ. ± 100 ppm/ $^{\circ}\text{C}$ ($V_{SET} < 1.75$ V)
- Line Regulation Typ. 0.02%/V
- Settable Output Voltage 0.9 V/ 1.0 V/ 1.1 V/ 1.2 V/ 1.25 V/ 1.35 V/ 1.5 V/ 1.75V/ 1.8 V
2.5 V/ 2.8 V 3.0 V/ 3.3 V/ 3.4 V/ 3.9 V
- Built-in Short Current Limit Circuit Typ. 60 mA (RP115L: LCON = "Low")
- Built-in Peak Current Limit
- Built-in Thermal Shutdown Circuit Thermal Shutdown Temperature: 165°C
- Built-in Constant Slope Circuit for Start-up
- Built-in Inrush Current Suppression Circuit ... Typ. 300 mA (RP115L: LCON = "Low")
- Reverse Current Protection
- Recommended Ceramic Capacitors 1.0 μF or more
- Output Noise $17 \times V_{SET}$ μV_{rms} (BW = 10 Hz to 100 kHz, $V_{SET} < 1.75$ V)
- Package DFN2020-8B, SOT-89-5

APPLICATIONS

- Power supply for electronic control units such as EV inverter and battery charge control unit.

SELECTION GUIDE

The package type, the set output voltage and the auto-discharge⁽¹⁾ are user-selectable options.

Selection Guide

Product Name	Package	Quantity per Reel	Pb Free	Halogen Free
RP115Lxx2*(y)-TR-#	DFN2020-8B	3,000 pcs	Yes	Yes
RP115Hxx1*(y)-T1-#E	SOT-89-5	1,000 pcs	Yes	Yes

xx: Set Output Voltage (V_{SET})

0.9 V (09) / 1.0 V (10) / 1.1 V (11) / 1.2 V (12) / 1.5 V (15) / 1.8 V (18) / 2.5 V (25) / 2.8 V (28) /
3.0 V (30) / 3.3 V (33) / 3.4 V (34) / 3.9 V (39)

Note: Contact our sales representatives for other voltages.

xx, (y): Second Decimal Place of 1.25 V RP115x12x*5-TR-A

Second Decimal Place of 1.35 V RP115x13x*5-TR-A

Second Decimal Place of 1.75 V RP115L172*5-TR-A

*: Auto-discharge Option

(B) auto-discharge not included

(D) auto-discharge included

#: Quality Class

	Operating Temp. Range	Test Temp.
A	-40°C to 105°C	25°C, High

⁽¹⁾ Auto-discharge function quickly lowers the output voltage to 0 V by releasing the electrical charge in the external capacitor when the chip enable signal is switched from the active mode to the standby mode.

BLOCK DIAGRAMS

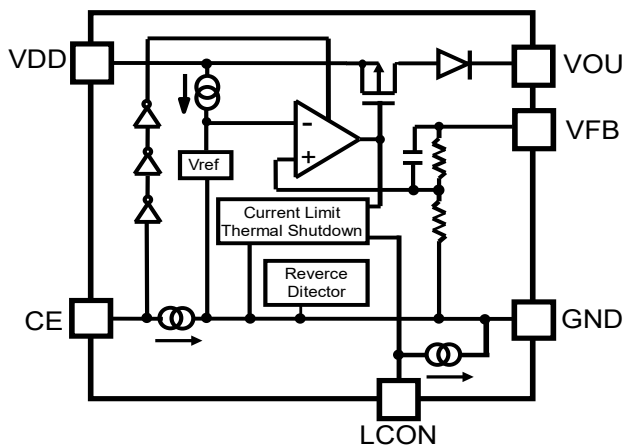

RP115Lxx2B Block Diagram

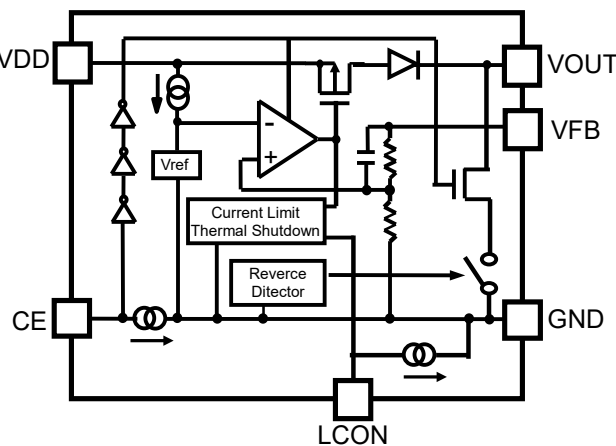

RP115Lxx2D Block Diagram

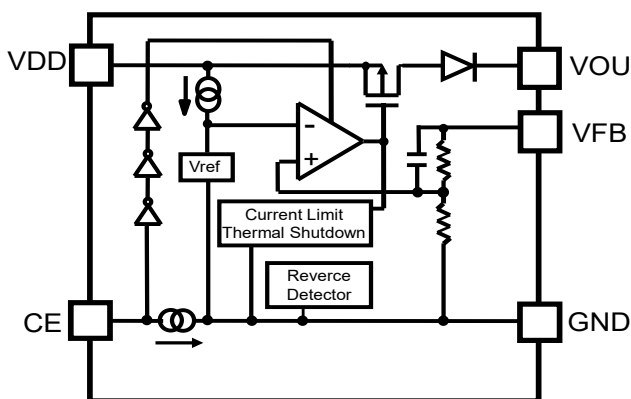

RP115Hxx1B⁽¹⁾ Block Diagram

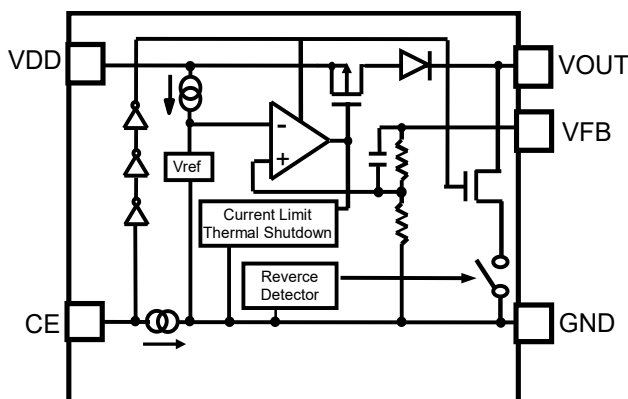

RP115Hxx1D⁽¹⁾ Block Diagram

⁽¹⁾ The RP115H does not have the LCON pin, so the output current is fixed at 1 A.

PIN DESCRIPTION

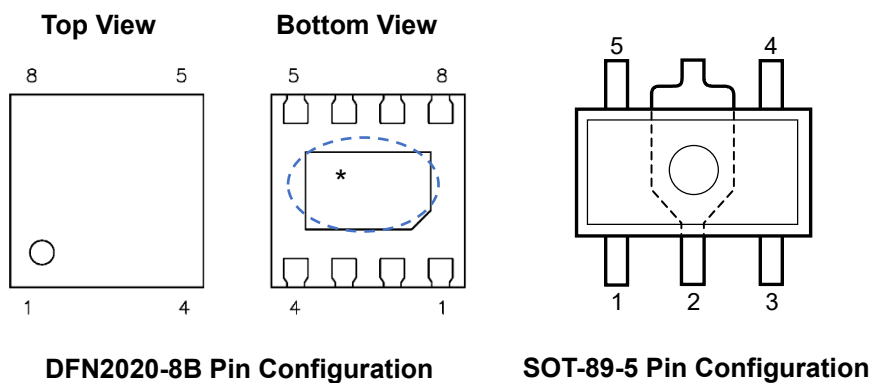

DFN2020-8B Pin Configuration

SOT-89-5 Pin Configuration

RP115L: DFN2020-8B

Pin No	Symbol	Pin Description
1	VOUT ⁽¹⁾	Output Pin
2	VOUT ⁽¹⁾	Output Pin
3	LCON	Output Current Limit Alternate Pin (“H” = 1 A, “L” = 500 mA)
4	VFB ⁽¹⁾	Feedback Pin
5	GND	Ground Pin
6	CE	Chip Enable Pin
7	VDD ⁽²⁾	Input Pin
8	VDD ⁽²⁾	Input Pin

* The tab on the bottom of the package shown by blue circle is a substrate potential (GND). It is recommended that this tab be connected to the ground plane pin on the board but it is possible to leave the tab floating.

RP115H⁽³⁾: SOT-89-5

Pin No	Symbol	Pin Description
1	VFB ⁽¹⁾	Feedback Pin
2	GND	Ground Pin
3	CE	Chip Enable Pin
4	VDD	Input Pin
5	VOUT ⁽¹⁾	Output Pin

⁽¹⁾ The VOUT and the VFB pins must be wired together when mounting on the board.

⁽²⁾ The VDD pin must be wired together when mounting on the board.

⁽³⁾ Output Current Limit is fixed at 1 A.

ABSOLUTE MAXIMUM RATINGS

Absolute Maximum Ratings

Symbol	Parameter	Rating	Unit		
V _{IN}	Input Voltage	6.0	V		
V _{CE}	CE Pin Input Voltage	-0.3 to 6.0	V		
V _{LCON}	LCON Pin Input Voltage	-0.3 to 6.0	V		
V _{OUT}	Output Voltage	-0.3 to 6.0	V		
P _D	Power Dissipation ⁽¹⁾	JEDEC STD. 51-7	DFN2020-8B	2800	mW
		JEDEC STD. 51-7	SOT-89-5	3200	
T _j	Junction Temperature Range	-40 to 150	°C		
T _{stg}	Storage Temperature Range	-55 to 150	°C		

ABSOLUTE MAXIMUM RATINGS

Electronic and mechanical stress momentarily exceeded absolute maximum ratings may cause permanent damage and may degrade the life time and safety for both device and system using the device in the field. The functional operation at or over these absolute maximum ratings are not assured.

RECOMMENDED OPERATING CONDITIONS

Recommend Operating Conditions

Symbol	Parameter	Rating	Unit
V _{IN}	Input Voltage ⁽²⁾	1.4 to 5.25	V
T _a	Operating Temperature Range	-40 to 105	°C

RECOMMENDED OPERATING CONDITONS

All of electronic equipment should be designed that the mounted semiconductor devices operate within the recommended operating conditions. The semiconductor devices cannot operate normally over the recommended operating conditions, even if they are used over such ratings by momentary electronic noise or surge. And the semiconductor devices may receive serious damage when they continue to operate over the recommended operating conditions.

⁽¹⁾ Refer to *POWER DISSIPATION* for detailed information.

⁽²⁾ The maximum input voltage listed under *Electrical Characteristics* is 5.25 V. If for any reason the input voltage exceeds 5.25 V, it has to be no more than 5.5 V with 500 cumulative operating hours.

ELECTRICAL CHARACTERISTICS

$V_{IN} = V_{SET}^{(1)} + 1.0\text{ V}$, $I_{OUT} = 1\text{ mA}$, $C_{IN} = C_{OUT} = 1.0\text{ }\mu\text{F}$, unless otherwise noted.

The specifications in are guaranteed by design engineering at $-40^{\circ}\text{C} \leq T_a \leq 105^{\circ}\text{C}$.

RP115x (-AE) Electrical Characteristics

($T_a = 25^{\circ}\text{C}$)

Symbol	Parameter	Test Conditions/Comments	Min.	Typ.	Max.	Unit	
V_{OUT}	Output Voltage	$T_a = 25^{\circ}\text{C}$	$V_{SET} \geq 1.75\text{ V}$	x0.99		x1.01	V
			$V_{SET} < 1.75\text{ V}$	-18		+18	mV
		$-40^{\circ}\text{C} \leq T_a \leq 105^{\circ}\text{C}$	$V_{SET} \geq 1.75\text{ V}$	x0.981		x1.015	V
			$V_{SET} < 1.75\text{ V}$	Refer to <i>Output Voltage</i>			
I_{LIM}	Output Current Limit	$V_{IN} = V_{SET} + 0.5\text{ V}$	LCON = "L"	500			mA
			LCON = "H" ⁽²⁾	1.0			A
$\frac{\Delta V_{OUT}}{\Delta I_{OUT}}$	Load Regulation	$V_{IN} = V_{SET} + 0.5\text{ V}$ $1\text{ mA} \leq I_{OUT} \leq 500\text{ mA}$	LCON = "L"		1	20	mV
			LCON = "H" ⁽²⁾			40	
V_{DIF}	Dropout Voltage	Refer to <i>Dropout Voltage</i>					
I_{SS}	Supply Current	$I_{OUT} = 0\text{ mA}$		110	160	μA	
Istandby	Standby Current	$V_{CE} = 0\text{ V}$		0.5	30	μA	
$\frac{\Delta V_{OUT}}{\Delta V_{IN}}$	Line Regulation	$V_{SET} + 0.5\text{ V} \leq V_{IN} \leq 5.25\text{ V}$ ($V_{IN} \geq 1.4\text{ V}$)		0.02	0.10	%/V	
I_{SC}	Short Current Limit	$V_{OUT} = 0\text{ V}$ ⁽³⁾	LCON = "L"		60	95	mA
			LCON = "H" ⁽²⁾		110	155	
I_{CE}	CE Pull-down Current		0.05	0.3	0.6	μA	
V_{CEH}	CE Input Voltage "H"		1.0			V	
V_{CEL}	CE Input Voltage "L"				0.4	V	
I_{LCON}	LCON Pull-down Current (RP115L only)		0.05	0.3	0.6	μA	
V_{LCONH}	LCON Input Voltage "High" (RP115L only)		1.0			V	
V_{LCONL}	LCON Input Voltage "Low" (RP115L only)				0.4	V	

⁽¹⁾ V_{SET} = Set Output Voltage

⁽²⁾ RP115H: Same Electrical Characteristics as LCON = "H".

⁽³⁾ Short Current is the value when V_{OUT} and GND are short-circuited after the device starts up. Inrush Current flows when the device starts up while V_{OUT} and GND are short-circuited.

ELECTRICAL CHARACTERISTICS (continued)

$V_{IN} = V_{SET}^{(1)} + 1.0\text{ V}$, $I_{OUT} = 1\text{ mA}$, $C_{IN} = C_{OUT} = 1.0\text{ }\mu\text{F}$, unless otherwise noted.

The specifications in are guaranteed by design engineering at $-40^{\circ}\text{C} \leq T_a \leq 105^{\circ}\text{C}$.

RP115x (-AE) Electrical Characteristics

($T_a = 25^{\circ}\text{C}$)

Symbol	Parameter	Test Conditions/Comments	Min.	Typ.	Max.	Unit
T_{TSD}	Thermal Shutdown Threshold Temperature	T_j , Rising		165		$^{\circ}\text{C}$
T_{TSR}	Thermal Shutdown Threshold Temperature	T_j , Falling		110		$^{\circ}\text{C}$
I_{REV}	Reverse Current	$V_{OUT} = V_{SET} + 1.0\text{ V}$ $0 \leq V_{IN} \leq V_{OUT}$	$V_{SET} \geq 1.75\text{ V}$	7.5		μA
			$V_{SET} < 1.75\text{ V}$	10		
$V_{REV_DET}^{(2)}$	Detection Offset in Reverse Current Mode ⁽³⁾	$V_{OUT} \geq 0.7\text{ V}$, $0 \leq V_{IN} \leq 5.25\text{ V}$		20		mV
$V_{REV_REL}^{(4)}$	Release Offset in Reverse Current Mode ⁽³⁾	$V_{OUT} \geq 0.7\text{ V}$, $0 \leq V_{IN} \leq 5.25\text{ V}$		30	50	mV
R_{LOW}	Low-output Nch Tr. ON Resistance (RP115xxxD only)	$V_{IN} = 4.0\text{ V}$, $V_{CE} = 0\text{ V}$		60		Ω
I_{RUSH}	Inrush limited Current	CC mode ⁽⁵⁾	LCON = "L"	300		mA
			LCON = "H" ⁽⁶⁾	500		

All test items listed under Electrical Characteristics are done under the pulse load condition ($T_j \approx T_a = 25^{\circ}\text{C}$) except Output Noise, Ripple Rejection, and Output Voltage Temperature Coefficient.

⁽¹⁾ V_{SET} = Set Output Voltage

⁽²⁾ $V_{REV_DET} = V_{IN} - V_{OUT}$

⁽³⁾ Guaranteed operating range of reverse current protection circuit is $V_{OUT} \geq 0.7\text{ V}$. When $V_{IN} = V_{OUT} = 0\text{ V}$, reverse current protection mode is constantly active.

⁽⁴⁾ $V_{REV_REL} = V_{IN} - V_{OUT}$

⁽⁵⁾ For CC (Constant Current) Mode, please refer to *Start-up Characteristics*.

⁽⁶⁾ RP115H: Same Electrical Characteristics as LCON = "High".

Output Voltage

Product Name	Output Voltage V_{OUT} (V)		
	Min.	Typ.	Max.
RP115x09x	0.862	0.9	0.930
RP115x10x	0.960	1.0	1.031
RP115x11x	1.058	1.1	1.133
RP115x12x	1.156	1.2	1.234
RP115x12x5	1.205	1.25	1.285
RP115x13x5	1.303	1.35	1.386
RP115x15x	1.449	1.5	1.538

Dropout Voltage

($T_a = 25^\circ\text{C}$)

Set Output Voltage V_{SET} (V)	Dropout Voltage V_{DIF} (V)					
	RP115L				RP115H	
	$I_{OUT} = 500 \text{ mA}$		$I_{OUT} = 1000 \text{ mA}$		$I_{OUT} = 1000 \text{ mA}$	
	Typ.	Max.	Typ.	Max.	Typ.	Max.
0.9 V, 1.0 V	*	*	*	*	*	*
1.1 V	*	*	*	0.375	*	0.365
1.2 V, 1.25 V	*	*	0.195	0.355	0.235	0.345
1.35 V	0.095	0.185	0.185	0.345	0.225	0.335
1.5 V	0.085	0.170	0.165	0.320	0.205	0.310
1.75 V, 1.8 V, 2.5 V	0.075	0.160	0.150	0.295	0.190	0.285
2.8 V, 3.0 V	0.065	0.145	0.130	0.265	0.170	0.255
3.3 V, 3.4 V, 3.9 V	0.060	0.135	0.125	0.250	0.165	0.240

If the dropout voltage falls below the release offset value of reverse current protection mode (V_{REV_REL}), the reverse current protection circuit may repeat the detection and release operations. Please refer to *Reverse Current Protection*.

* Input voltage should be equal or more than the minimum operating voltage (1.4 V).

THEORY OF OPERATION

Reverse Current Protection

The RP115x includes a reverse current protection circuit in order to stop the reverse current from VOUT pin to VDD pin or to GND pin when VOUT becomes higher than VIN.

Usually, the LDO using Pch output transistor contains a parasitic diode between VDD pin and VOUT pin.

Therefore, if VOUT is higher than VIN, the parasitic diode becomes forward direction. As a result, the current flows from VOUT pin to VDD pin.

The RP115x switches the mode to the reverse current protection mode before VIN becomes lower than VOUT by connecting the parasitic diode of Pch output transistor to the backward direction, and connecting the gate to VOUT pin. As a result, the Pch output transistor is turned off. However, from VOUT pin to GND pin, via the internal divider resistors, very small current IREV flows.

Switching to either the normal mode or to the reverse current protection mode is determined by the magnitude of VIN voltage and VOUT voltage. For the stable operation, offset and hysteresis are set as the threshold. The detector threshold is set to VREV_DET and the released voltage is set to VREV_REL. Therefore, the minimum dropout voltage under the small load current condition is restricted by the value of VREV_REL.

Following figures show the diagrams of each mode, and the load characteristics of each mode. When giving the VOUT pin a constant-voltage and decreasing VIN, the dropout voltage will become lower than VREV_DET. As a result, the reverse current protection starts to function to stop the load current.

By increasing the dropout voltage higher than VREV_REL, the protection mode will be released to let the load current to flow. If the dropout voltage to be used is lower than VREV_REL, the detection and the release may be repeated.

The operating voltage guaranteed level of the reverse current protection circuit is for VOUT ≥ 0.7 V. If VIN = 0 V, the reverse current protection mode becomes always active.

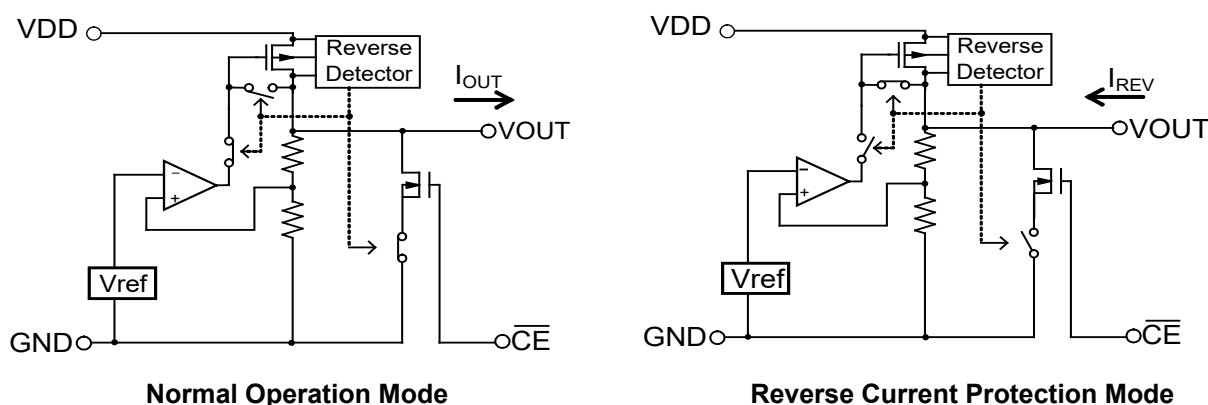

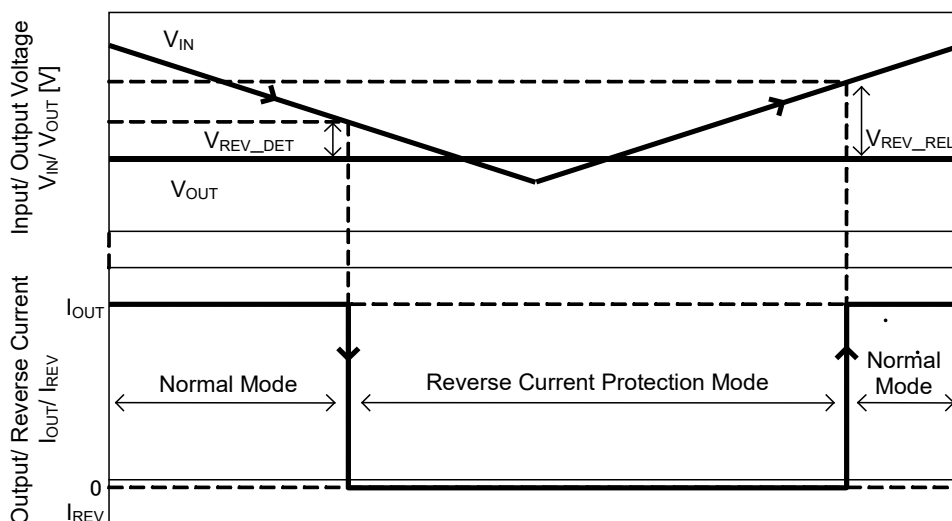

Detection/ Release Timing of Reverse Current Protection Function

Constant Slope for Start-Up Characteristics

The RP115x includes a constant slope circuit in order to prevent the overshoot of the output voltage. The start-up time (t_{ON}) is 100 μ s (Typ.). If inrush current increases due to the large capacitance of C_{OUT} , the operation mode will be shifted from Constant Slope (CS) mode to Constant Current (CC) mode. The CC mode maintains a constant level of inrush current. In the CC mode, t_{ON} varies according to the size of C_{OUT} and the amount of load current.

Start-up Time and Inrush Current Estimations

Start-up time and inrush current in the CS mode and the CC mode can be estimated as follows. The following is described the how to estimate when using the RP115L. The RP115H has the same electrical characteristics as LCON = "H" in the RP115L.

[CS Mode]

Start-up Time (t_{ON}): 100 μ s (Typ.)

Inrush Current (I_{RUSH}): $C_{OUT} \cdot V_{SET} / t_{ON} + I_{OUT}^{(1)}$

Note: If the result of the above calculation is more than the following values, the operation mode will be shifted from the CS mode to the CC mode.

LCON = "L" 300 mA (Typ.)

LCON = "H" 500 mA (Typ.)

[CC Mode]

Start-up Time (t_{ON}): $C_{OUT} \cdot V_{SET} / I_{CO}^{(2)}$

Inrush Current (I_{RUSH}): LCON = "L" 300 mA (Typ.)

LCON = "H" 500 mA (Typ.)

⁽¹⁾ I_{OUT} : When R_{LOAD} is connected to load, I_{OUT} can be calculated by $R_{LOAD} = V_{SET} / I_{OUT}$.

⁽²⁾ I_{CO} : I_{CO} is a charge current of C_{OUT} and can be calculated roughly by $I_{RUSH} \approx I_{CO} + I_{OUT}$.

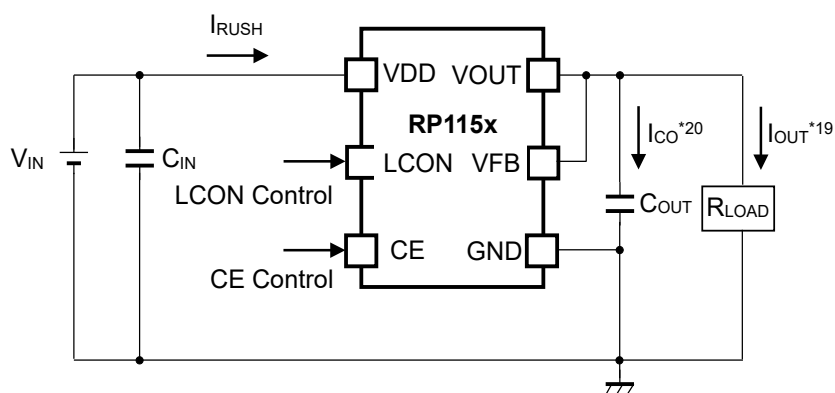

Circuit Example of RP115L

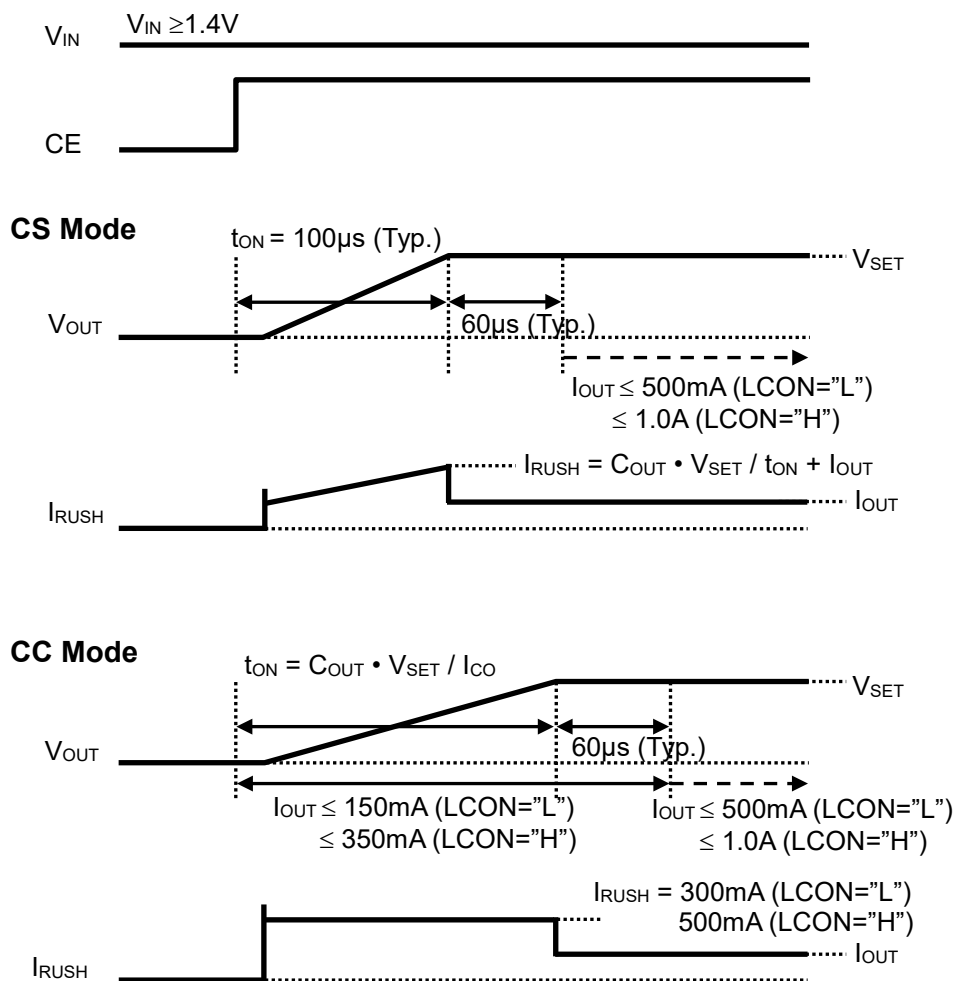

Start-up Operation Diagram

Precautions before Use

During the start-up, the inrush current limit circuit is in operation; therefore, the load current (I_{OUT}) should be drawn after the output voltage (V_{OUT}) reached the preset value (Best timing: $t_{ON} + 60\mu s$ or more). If the load current is drawn during the start-up, it should be within the following values.

LCON = "L" $I_{OUT} \leq 150 \text{ mA}$

LCON = "H" $I_{OUT} \leq 350 \text{ mA}$

In the CC mode, I_{RUSH} is limited until V_{OUT} reaches the preset value. $I_{RUSH} \approx I_{CO} + I_{OUT}$ is true; therefore, if large I_{OUT} is drawn during the start-up, the charge current (I_{CO}) of C_{OUT} decreases and t_{ON} becomes longer. Please refer to *Start-up Time and Inrush Current Estimations*.

In order to control the start-up operation by using the CS mode or CC mode, input "H" into the CE pin while $V_{IN} \geq 1.4 \text{ V}$. If "H" is input into the CE pin while V_{IN} is less than the minimum operating voltage, the operation may not be controlled by the CS mode or CC mode.

When starting up the device while the short circuit is occurring between the V_{OUT} pin and GND, the short current protection circuit does not control the current but the current limit circuit does.

When there's excessive heat generation in the device, thermal shutdown circuit shuts down the circuitry before the device overheats dangerously.

LCON Pin Operation (RP115L Only)

By alternating the LCON pin between "H" or "L", the RP115L can choose the output current limit either 1.0 A or 500 mA. Please note that during start-up ($t_{ON} + 60 \mu s$ (Typ.)), do not change the logic of the LCON pin.

LCON = "L" 500 mA

LCON = "H" 1.0 A

Application Example

Even when using the RP115L with LCON = "H", I_{RUSH} in the CC mode can be reduced from 500 mA (Typ.) to 300 mA (Typ.) by starting up the IC with LCON = "L". Please refer to *Start-Up Characteristics*.

APPLICATION INFORMATION

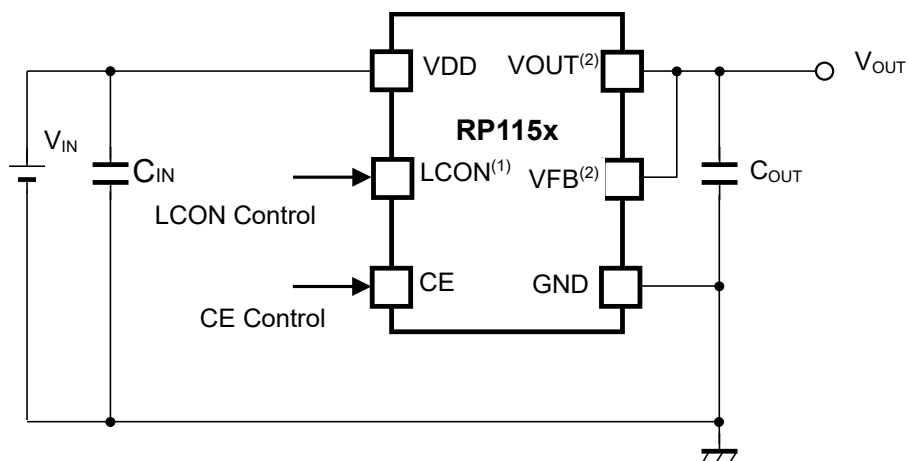

RP115x Typical Application Circuit

External Components Example:

Symbol	Descriptions
C _{IN}	1.0 μF, Ceramic Capacitor, CGA3E1X7R1C105K080AC (TDK)
C _{OUT}	1.0 μF, Ceramic Capacitor, CGA3E1X7R1C105K080AC (TDK) 2.2 μF, Ceramic Capacitor, CGA4J3X7R1C225K125AB (TDK)

Precautions When Selecting External Components

- Connect a capacitor of 1.0 μF or more as C_{OUT} to secure stable operation even when the load current is varied. (for phase compensation)
- Depending on the capacitor size, manufacturer, and part number, the bias characteristics and temperature characteristics are different. Evaluate the circuit taking actual characteristics into account. Especially for the 1.75-V-output product, it is recommended to use 2.2 μF or higher output capacitor when the product is used under the low-temperature environment such as -20°C or lower.
- If using a tantalum type capacitor and the ESR value of the capacitor is large, the output might be unstable. Evaluate your circuit including consideration of frequency characteristics.

⁽¹⁾ The LCON pin is only included in RP115L (DFN2020-8B).

⁽²⁾ The VOUT pin and the VFB pin should be wired together when mounting on the board.

Equivalent Series Resistance (ESR) vs. Output Current

Ceramic type output capacitor is recommended for the RP115x but any capacitor with low ESR can be used. The graphs below show the relation between I_{OUT} and ESR (noise level: average 40 μ V or less).

Measurement Conditions

- Noise Frequency Band Width: 10 Hz to 2 MHz
- Operating Temperature Range: -40°C to $+85^{\circ}\text{C}$
- Hatched Area: Output noise level is average 40 μ V or less.
- C_{IN} , C_{OUT} : 1.0 μ F or more

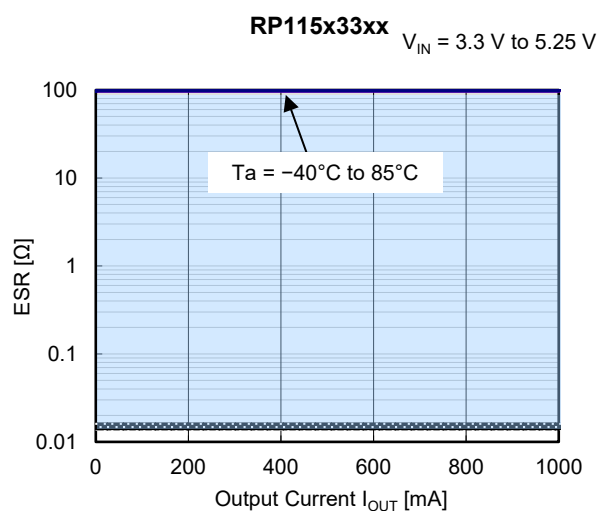
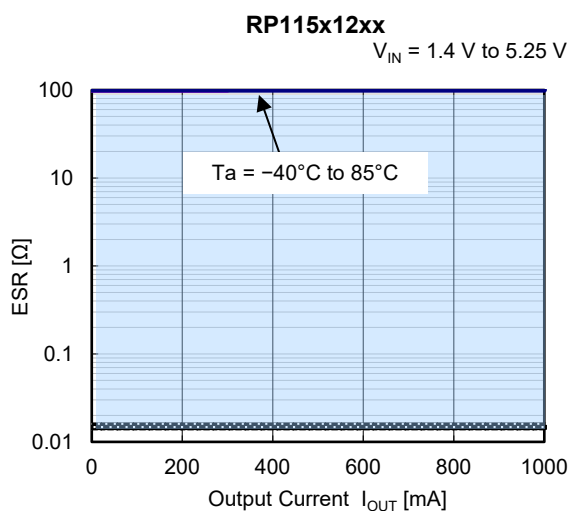

TECHNICAL NOTES

The performance of a power source circuit using this device is highly dependent on a peripheral circuit. A peripheral component or the device mounted on PCB should not exceed its rated voltage, rated current or rated power. When designing a peripheral circuit, please be fully aware of the following points.

- Ensure the V_{DD} and GND lines are sufficiently robust. If their impedance is too high, noise pickup or unstable operation may result. Connect a capacitor C_{IN} with 1.0 μ F or more between VDD and GND pins, and as close as possible to the pins.
- Connect C_{OUT} capacitor with suitable values between the VOUT and GND pins, and as close as possible to the pins.

TYPICAL CHARACTERISTICS

Note: Typical Characteristics are intended to be used as reference data; they are not guaranteed.

1) Output Voltage vs. Input Voltage (C_{IN} = Ceramic 1.0 μ F, C_{OUT} = Ceramic 1.0 μ F, T_a = 25°C)

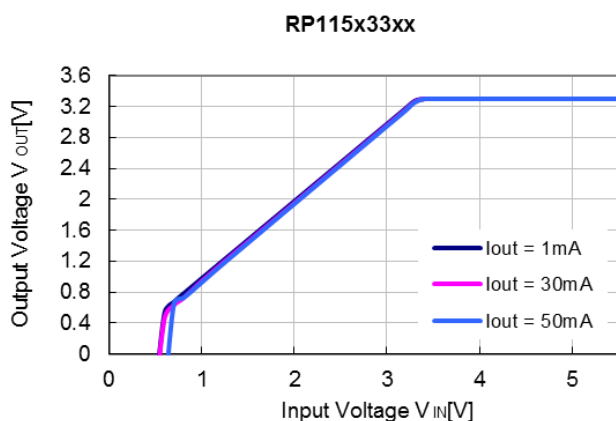
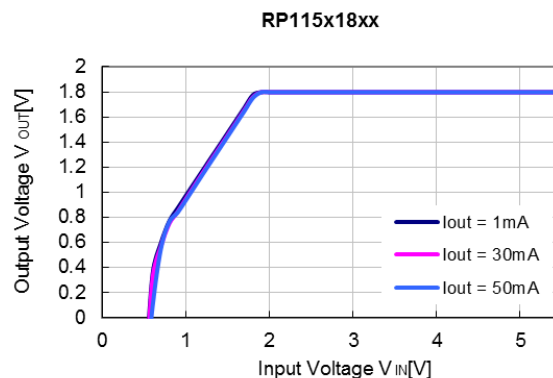
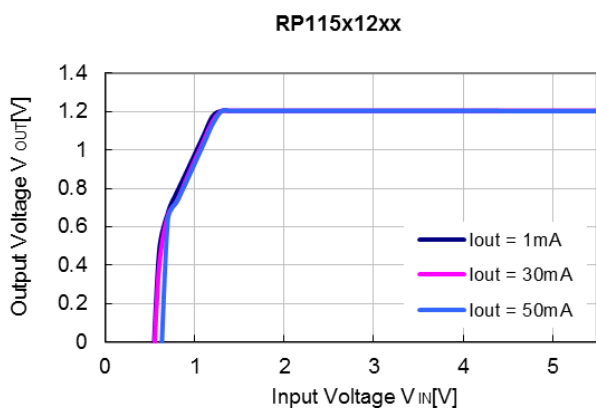

2) Supply Current vs. Input Voltage (C_{IN} = Ceramic 1.0 μ F, C_{OUT} = Ceramic 1.0 μ F, T_a = 25°C)

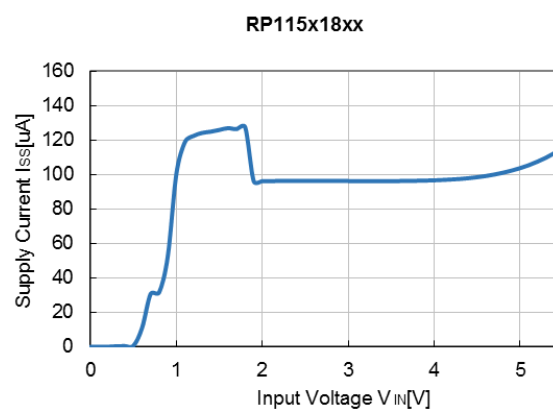
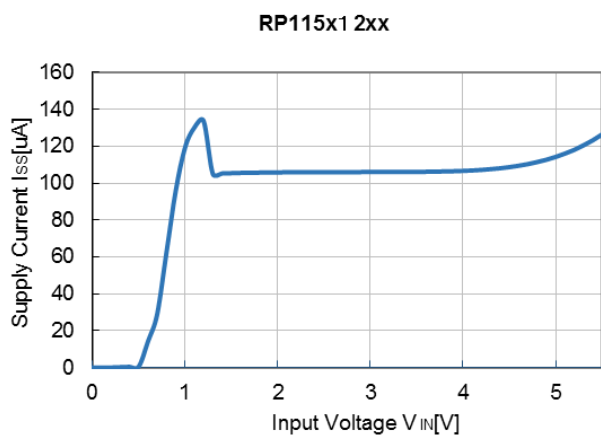

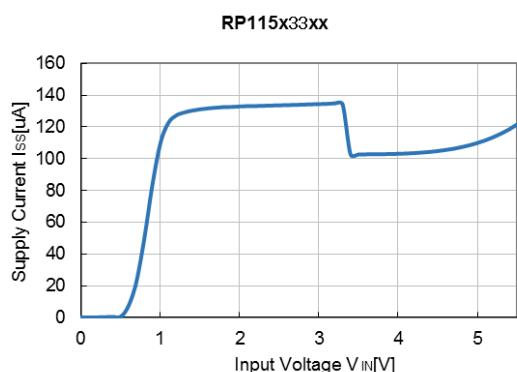

Note: The RP115x contains a peak current limit circuit which protect the regulator from damage by overcurrent if the output pin (V_{OUT}) and the ground pin (GND) are shorted. The short-circuiting causes the overheating of the device which leads a thermal shutdown circuit to operate. If the peak current limit circuit and the thermal shutdown circuit work at the same time, fold-back type dropping characteristics cannot be measured. As for the short-circuit current and the peak current limit circuit, please refer to 3) Short Current Limit vs. Ambient Temperature and 4) Peak Current Limit vs. Ambient Temperature.

3) Short Current Limit vs. Ambient Temperature (C_{IN} = Ceramic 1.0 µF, C_{OUT} = Ceramic 1.0 µF)

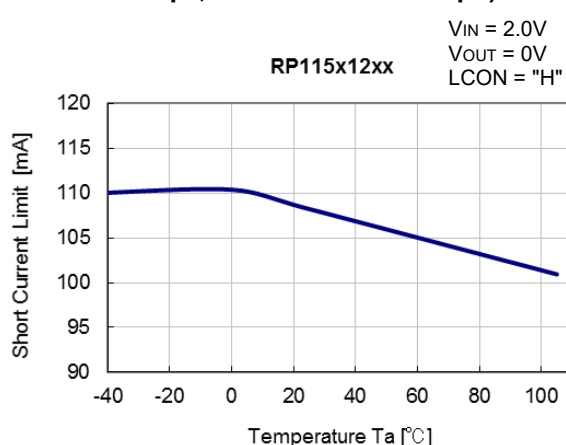
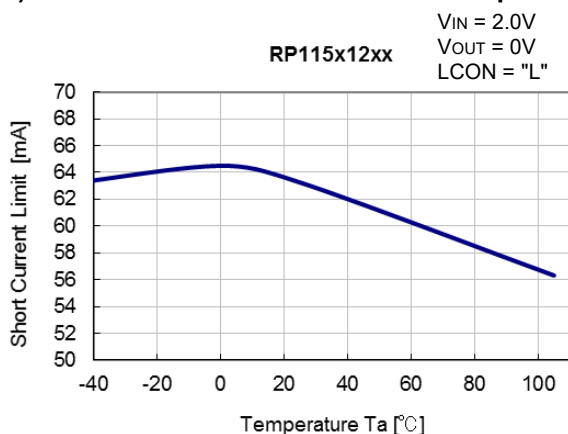

4) Peak Current Limit vs. Ambient Temperature (C_{IN} = Ceramic 1.0 µF, C_{OUT} = Ceramic 1.0 µF)

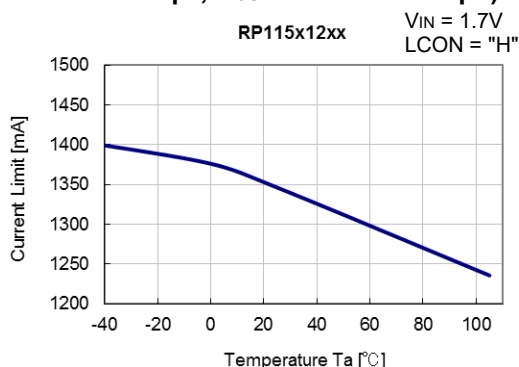
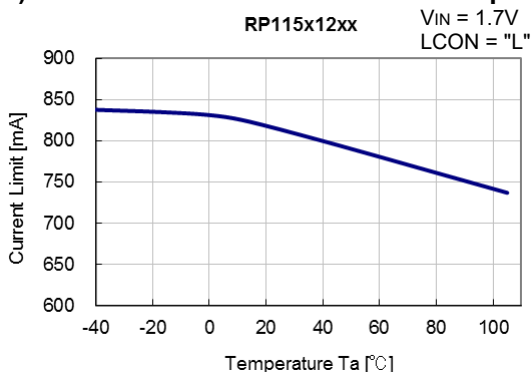

5) Output Voltage vs. Ambient Temperature (C_{IN} = Ceramic 1.0 μ F, C_{OUT} = Ceramic 1.0 μ F, I_{OUT} = 1 mA)

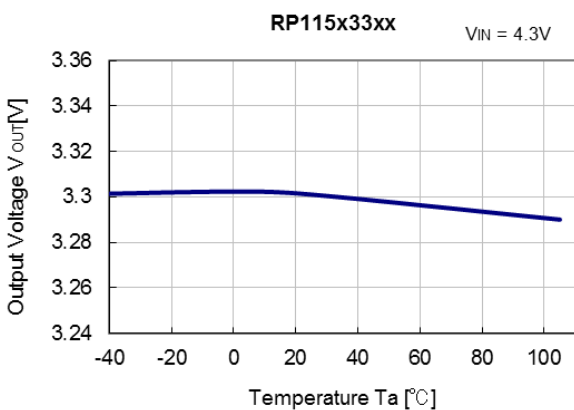
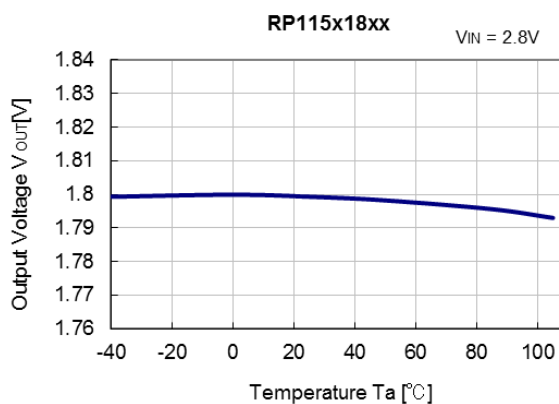
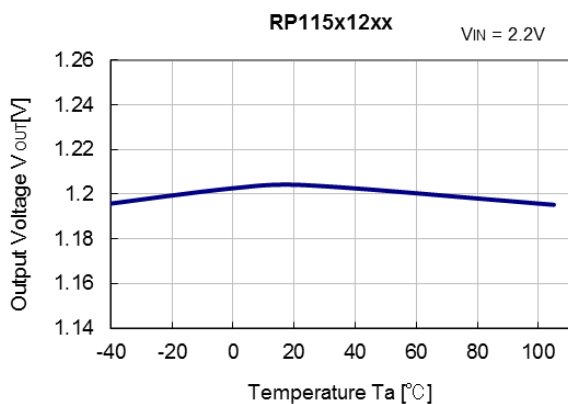

6) Supply Current vs. Ambient Temperature (C_{IN} = Ceramic 1.0 μ F, C_{OUT} = Ceramic 1.0 μ F, I_{OUT} = 0 mA)

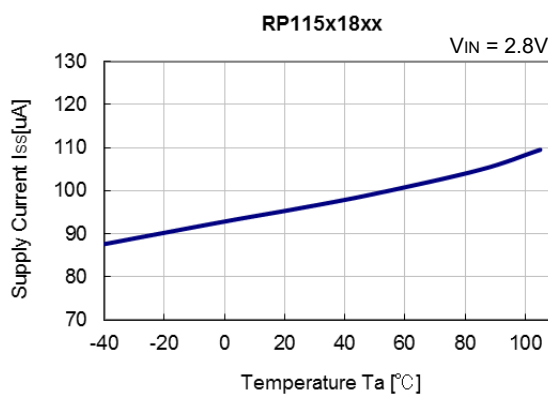
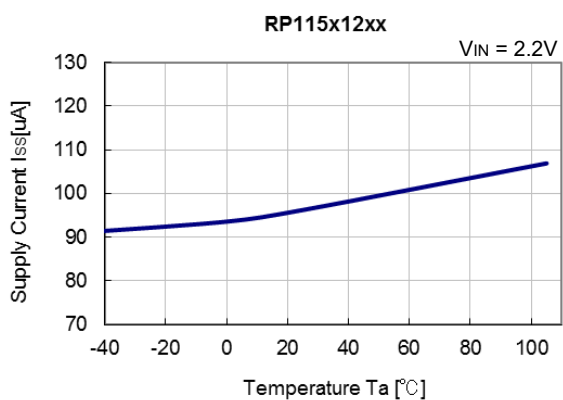

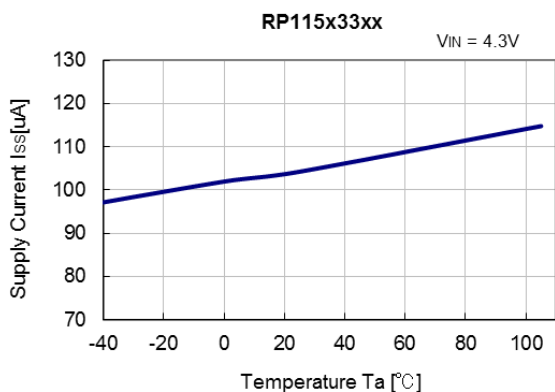

7) Dropout Voltage vs. Output Current ($C_{IN} = \text{Ceramic } 1.0 \mu F, C_{OUT} = \text{Ceramic } 1.0 \mu F$)

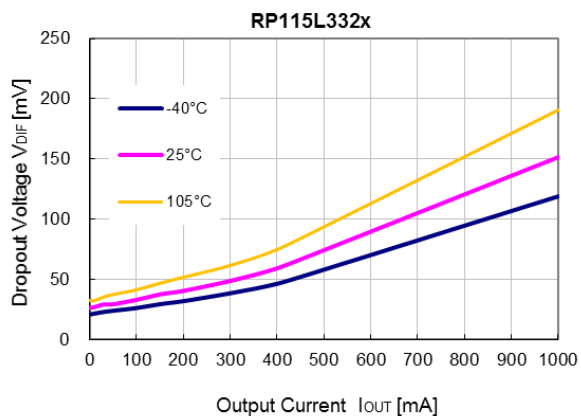
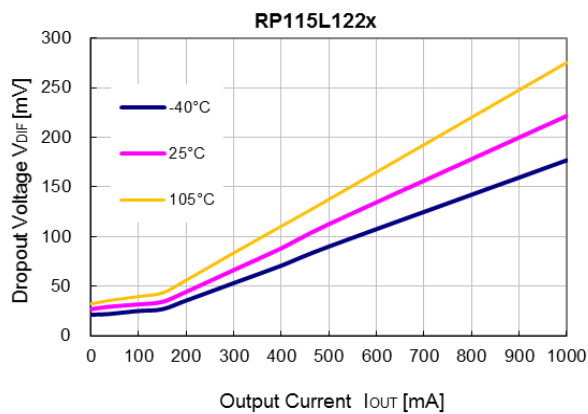
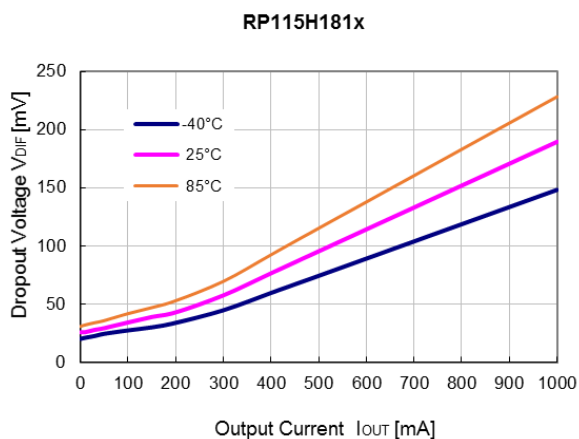

8) Dropout Voltage vs. Set Output Voltage ($C_{IN} = \text{Ceramic } 1.0 \mu\text{F}$, $C_{OUT} = \text{Ceramic } 1.0 \mu\text{F}$, $T_a = 25^\circ\text{C}$)

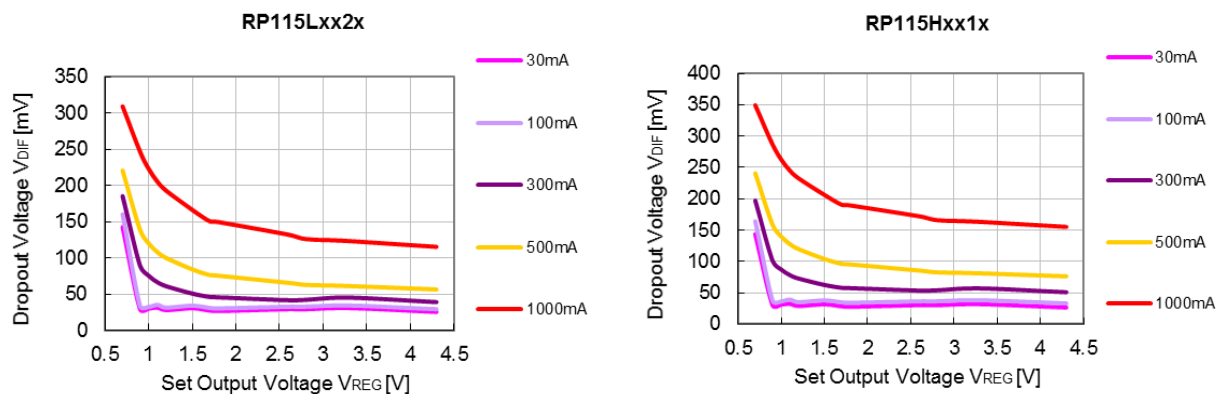

9) Dropout Voltage vs. Ambient Temperature ($C_{IN} = \text{Ceramic } 1.0 \mu\text{F}$, $C_{OUT} = \text{Ceramic } 1.0 \mu\text{F}$)

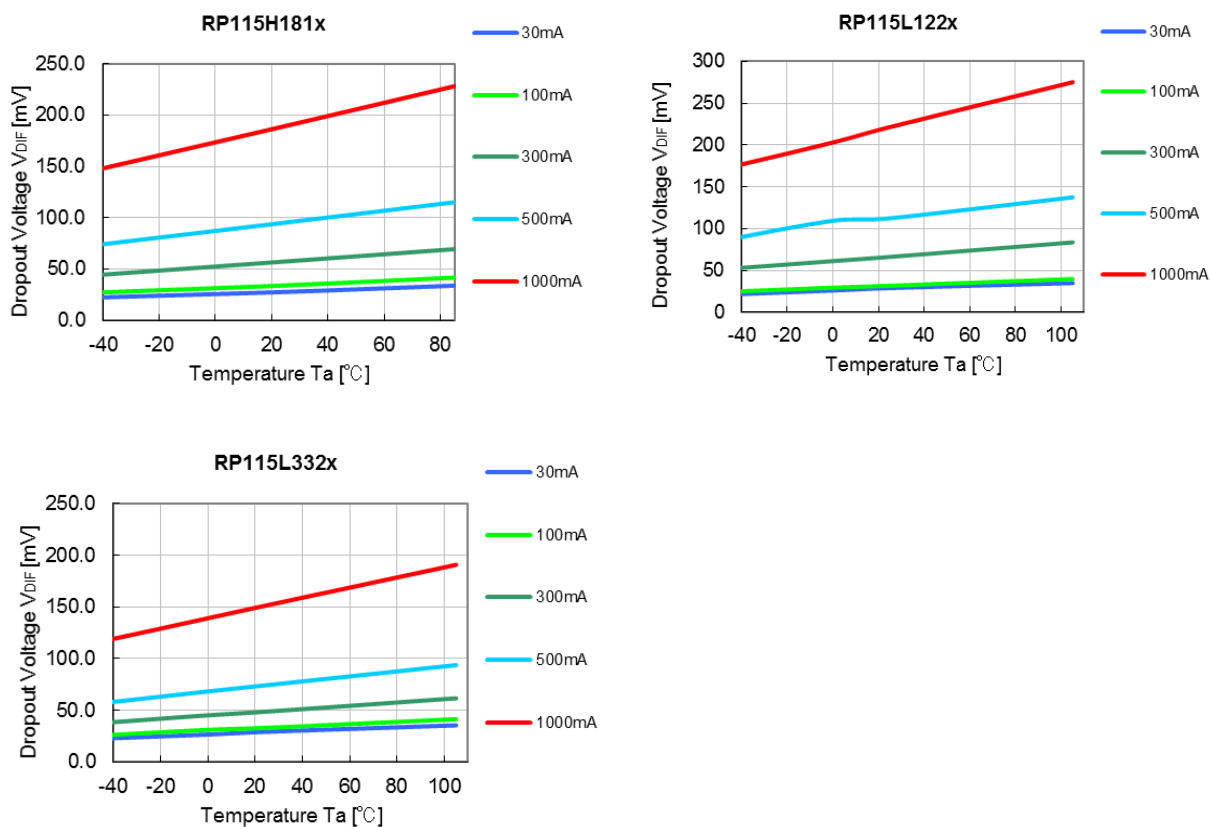

10) Ripple Rejection vs. Input Voltage (C_{IN} = none, C_{OUT} = Ceramic 1.0 μ F, Ripple = 0.2 Vp-p, T_a = 25°C)

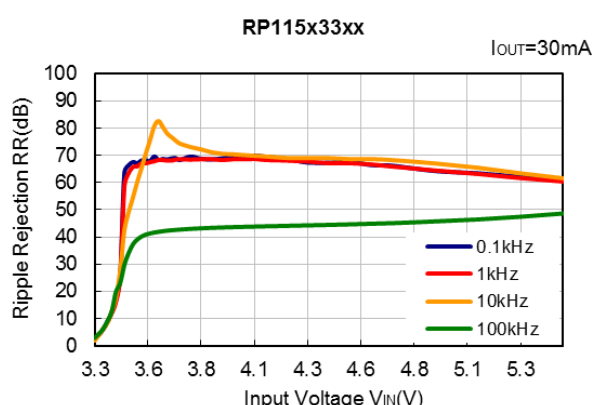
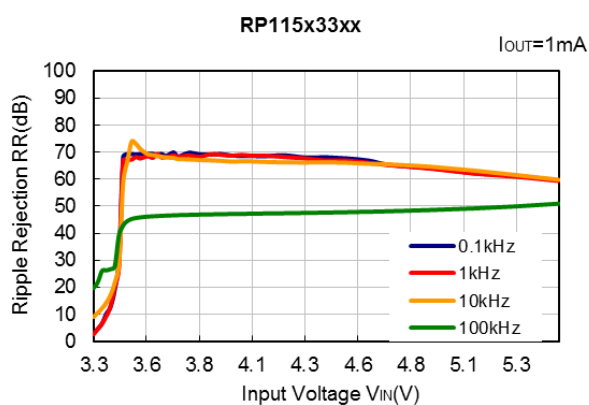
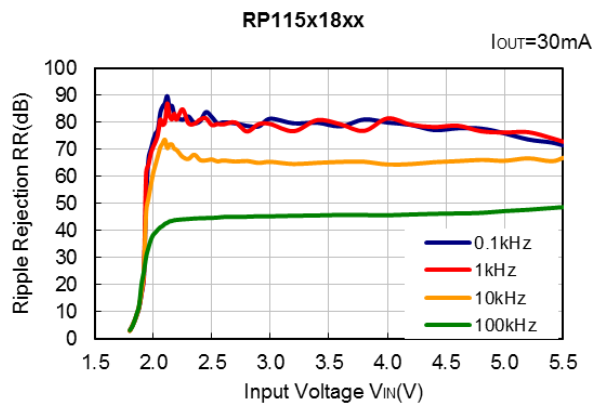
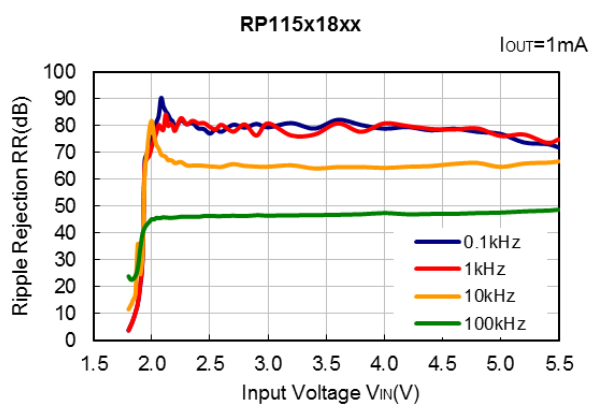
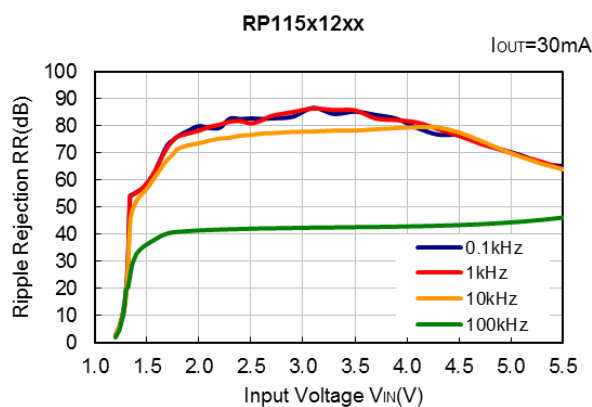
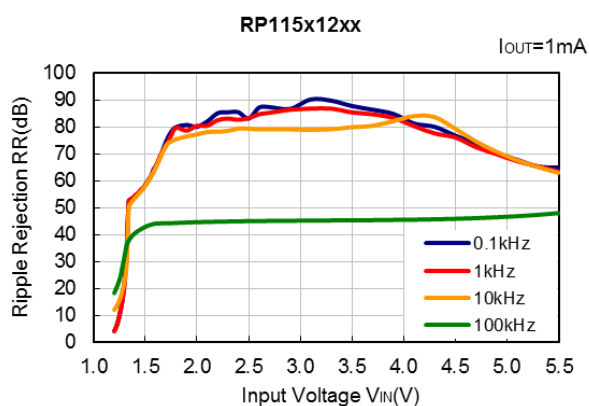

11) Ripple Rejection vs. Frequency (C_{IN} = none or $0.47 \mu\text{F}$, C_{OUT} = Ceramic $1.0 \mu\text{F}$, Ripple = 0.2 Vp-p , $T_a = 25^\circ\text{C}$)

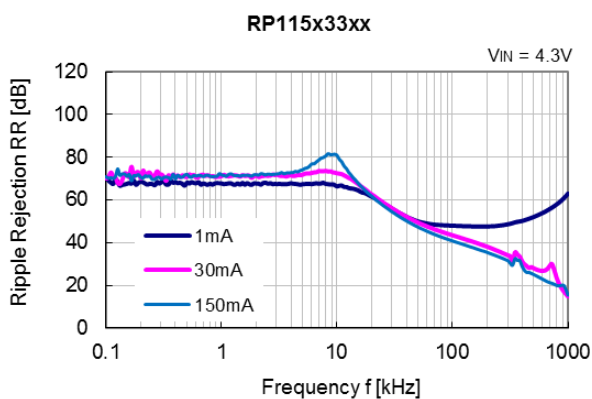
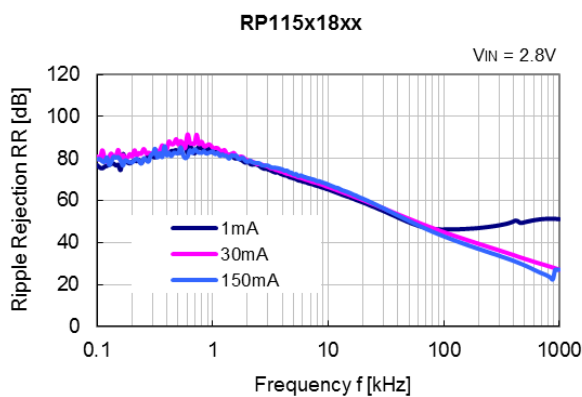
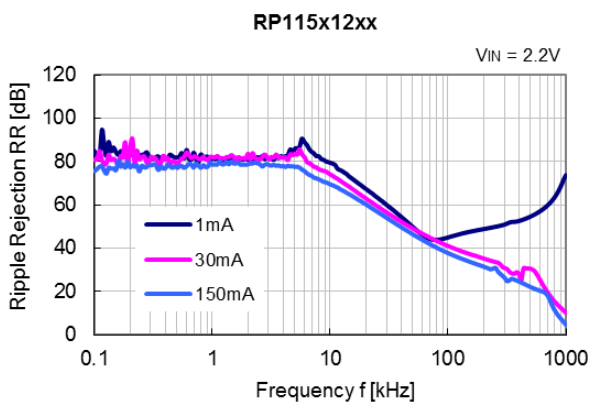

12) Line Transient Response (C_{IN} = none, C_{OUT} = Ceramic $1.0 \mu\text{F}$, $I_{OUT} = 30 \text{ mA}$, $t_r = t_f = 5 \mu\text{s}$, $T_a = 25^\circ\text{C}$)

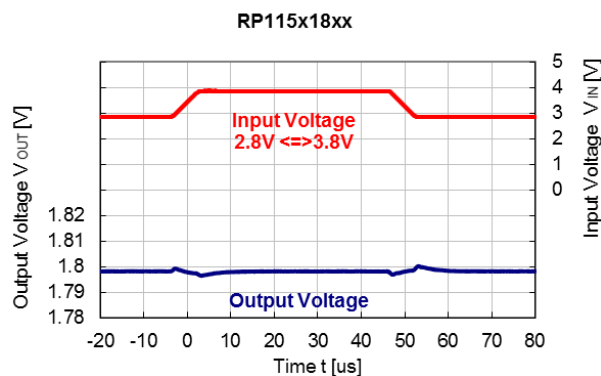
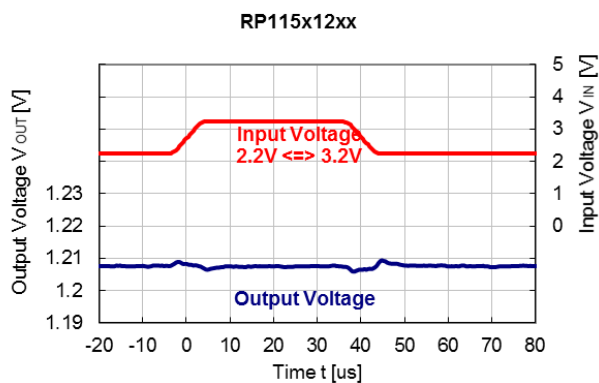

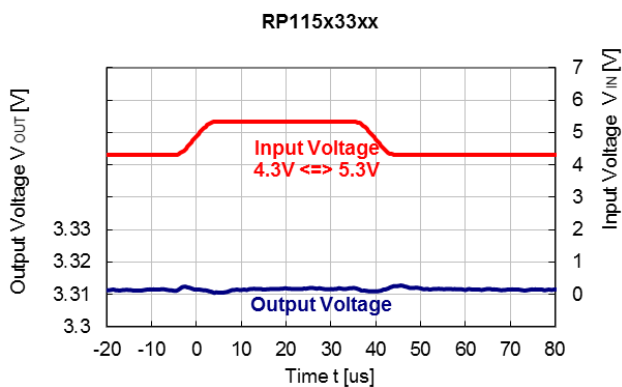

13) Load Transient Response (C_{IN} = Ceramic 1.0 μ F, C_{OUT} = Ceramic 1.0 μ F, $t_r = t_f = 0.5 \mu$ s, $T_a = 25^\circ$ C)

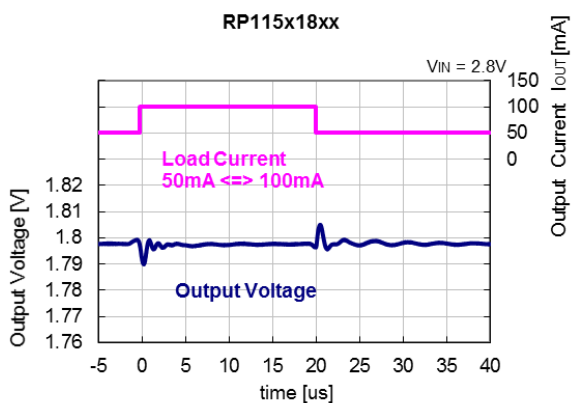
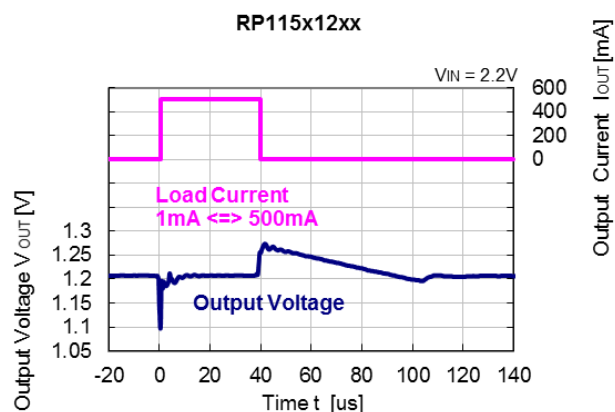
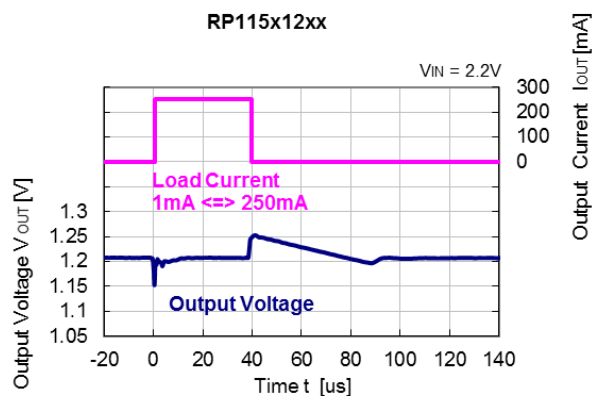
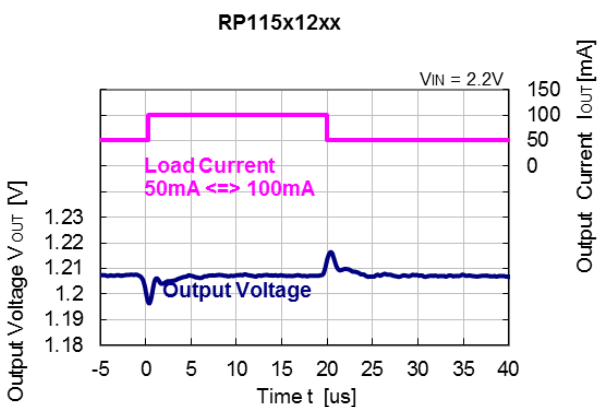

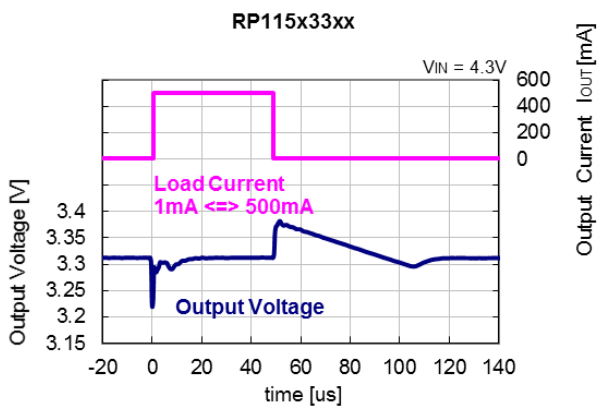
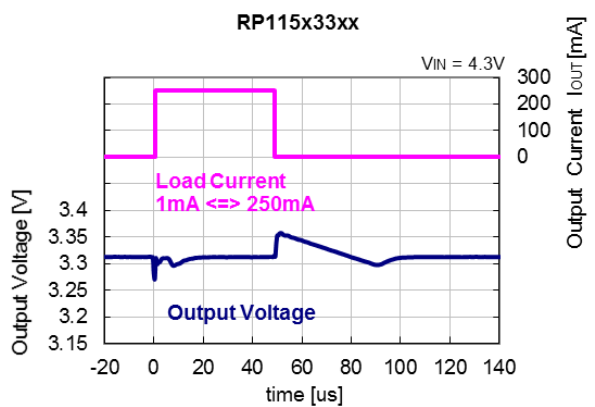
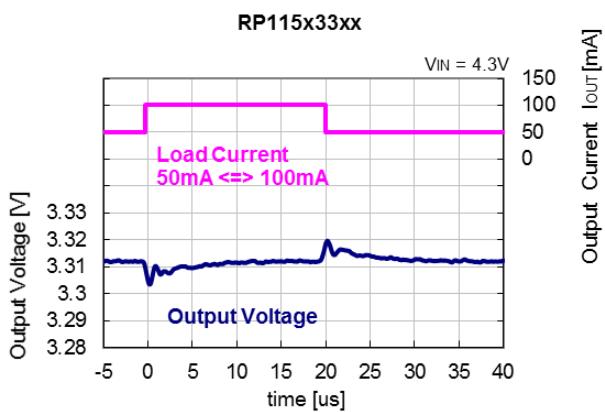
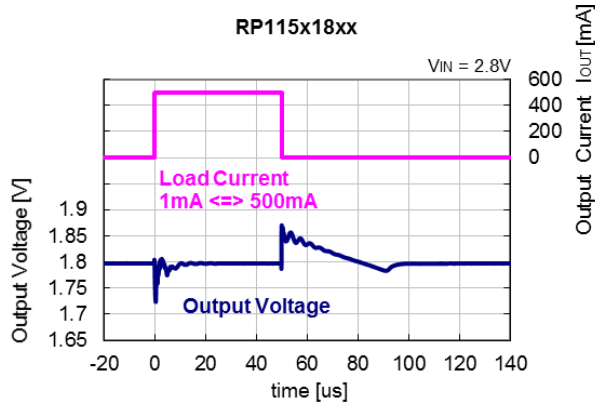
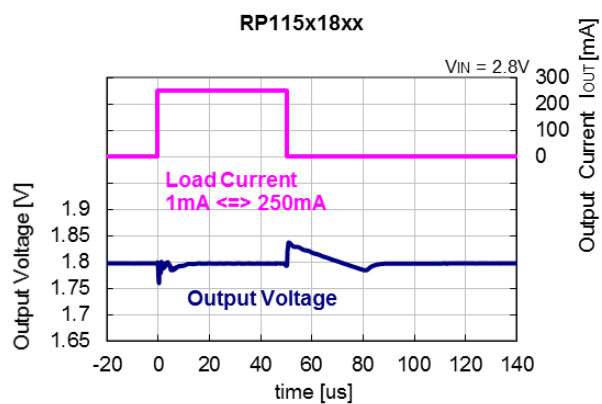

14) Turn-On Waveform Speed by CE Pin Signal ($C_{IN} = \text{Ceramic } 1.0 \mu\text{F}$, $C_{OUT} = \text{Ceramic } 1.0 \mu\text{F}$, $T_a = 25^\circ\text{C}$)

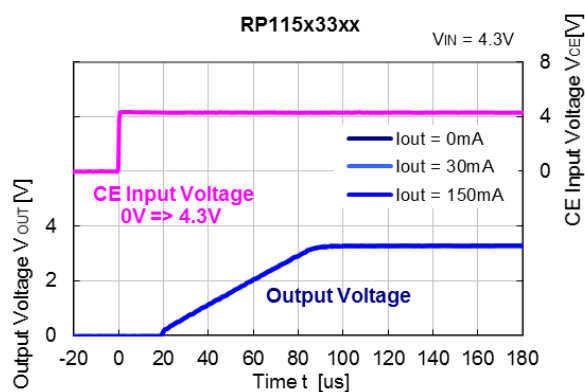
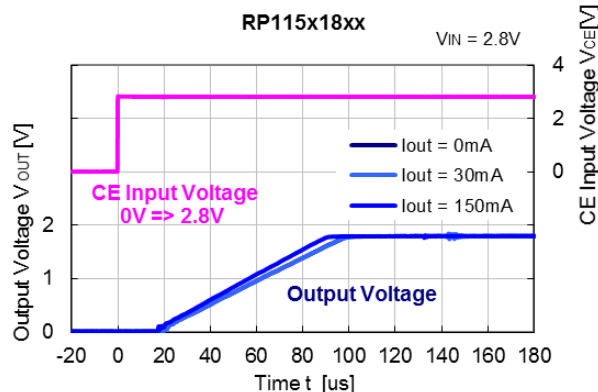
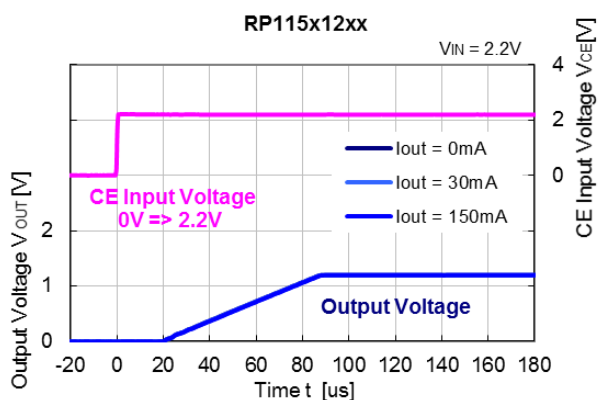

15) Turn-Off Waveform Speed by CE Pin Signal ($C_{IN} = \text{Ceramic } 1.0 \mu\text{F}$, $C_{OUT} = \text{Ceramic } 1.0 \mu\text{F}$, $T_a = 25^\circ\text{C}$)

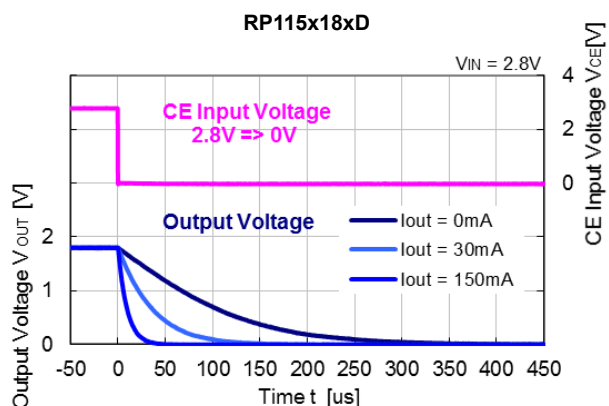
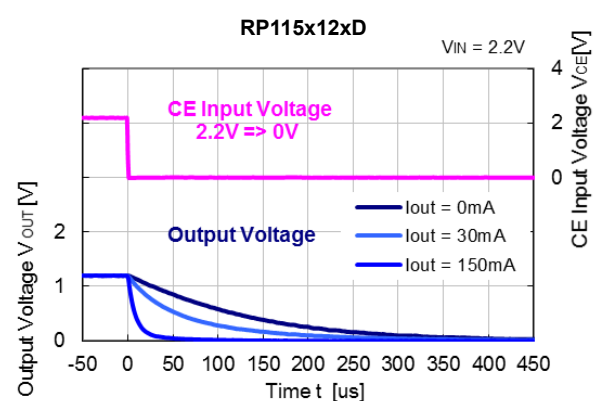

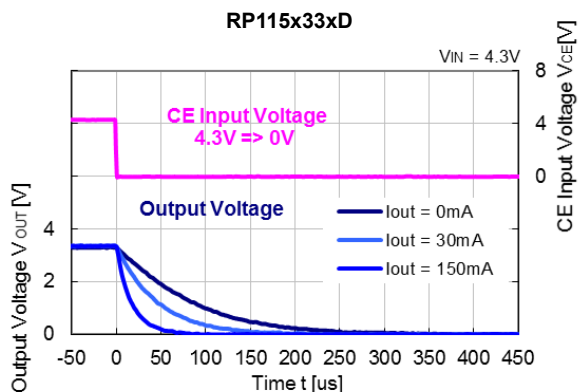

16) Inrush Current at Turning-On ($C_{IN} = \text{Ceramic } 1.0 \mu F, I_{OUT} = 0 \text{ mA}, T_a = 25^\circ C$)

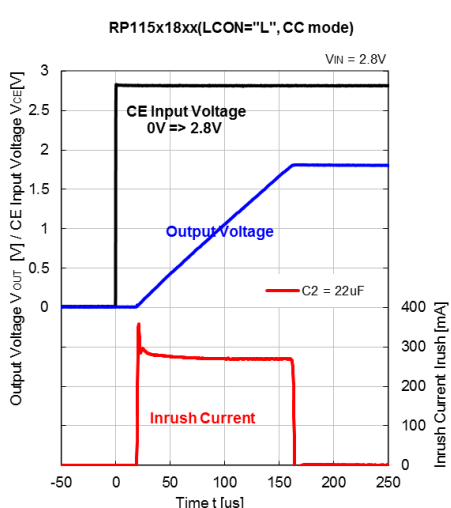
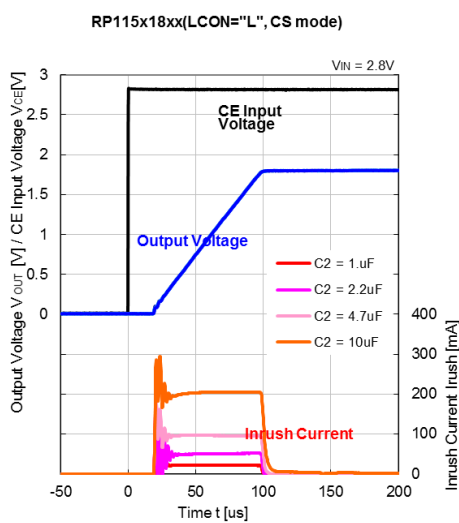
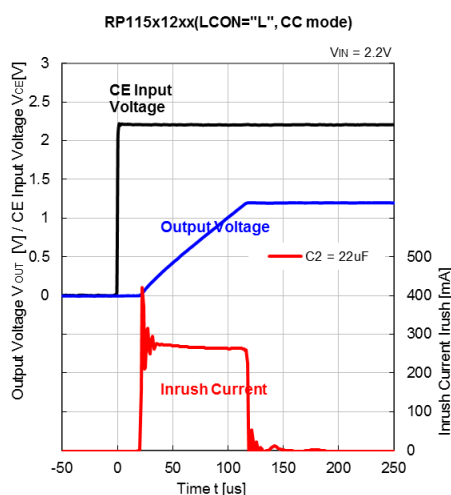
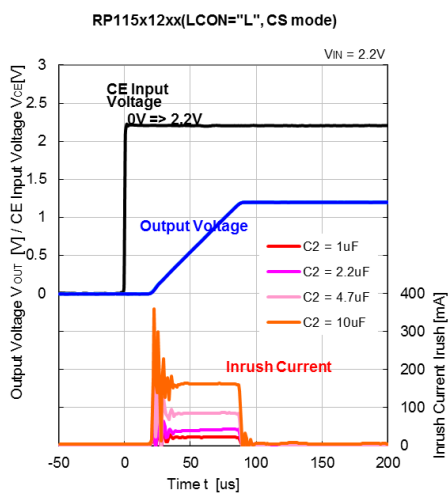

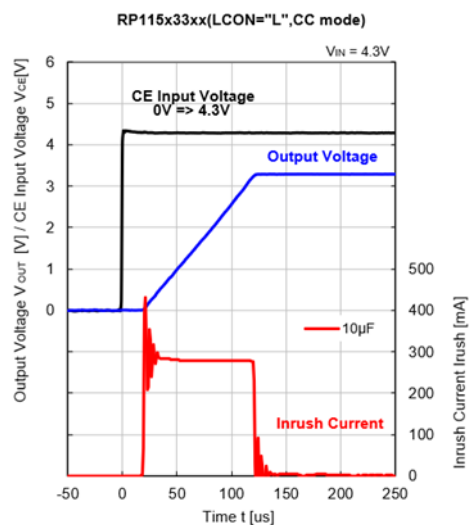
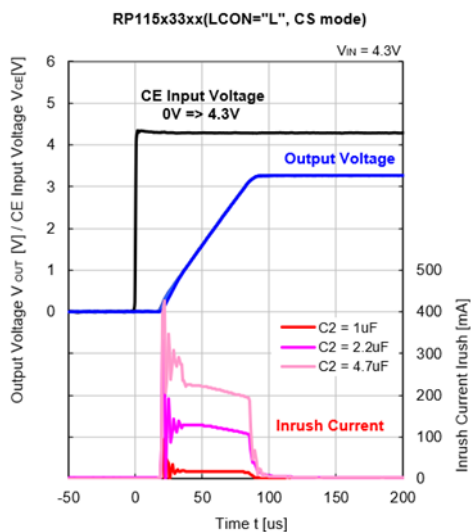

17) LCON Transient Response (C_{IN} = Ceramic 1.0 μ F, C_{OUT} = Ceramic 1.0 μ F, $t_r = t_f = 0.5 \mu$ s, $T_a = 25^\circ$ C)

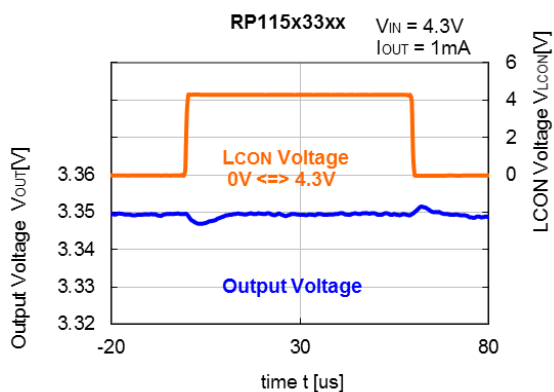
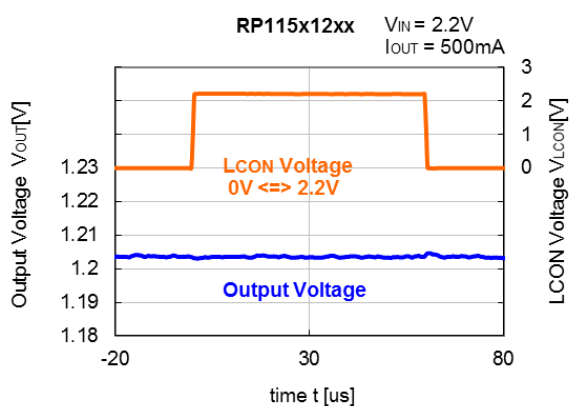
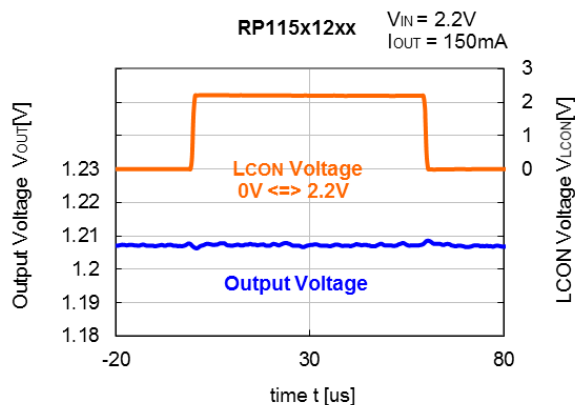
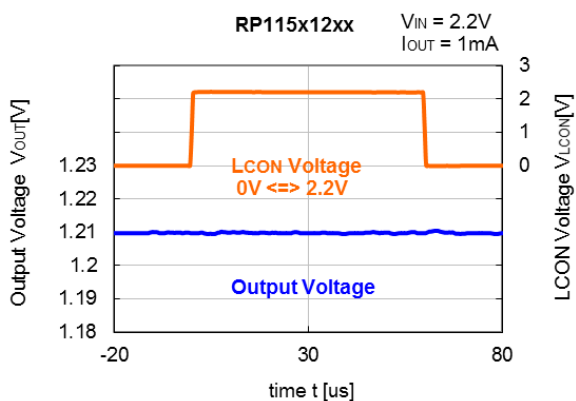

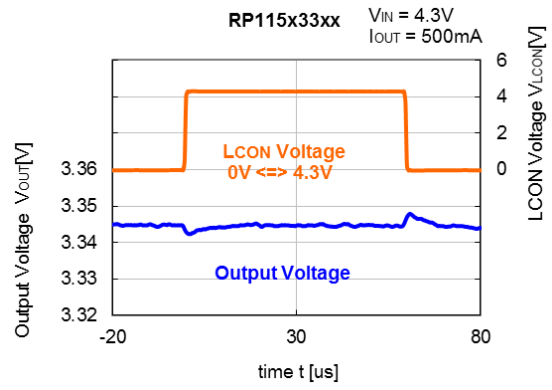
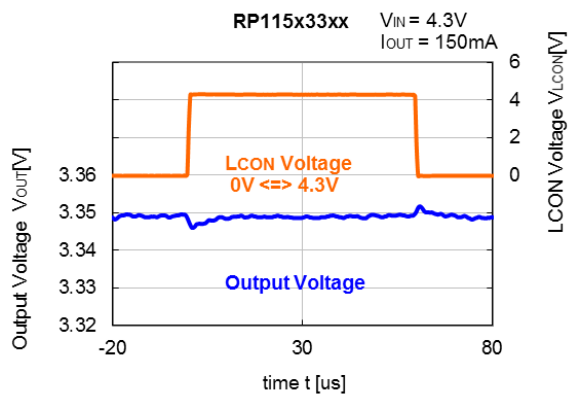

The power dissipation of the package is dependent on PCB material, layout, and environmental conditions. The following measurement conditions are based on JEDEC STD. 51-7.

Measurement Conditions

Item	Measurement Conditions
Environment	Mounting on Board (Wind Velocity = 0 m/s)
Board Material	Glass Cloth Epoxy Plastic (Four-Layer Board)
Board Dimensions	76.2 mm × 114.3 mm × 0.8 mm
Copper Ratio	Outer Layer (First Layer): Less than 95% of 50 mm Square Inner Layers (Second and Third Layers): Approx. 100% of 50 mm Square Outer Layer (Fourth Layer): Approx. 100% of 50 mm Square
Through-holes	φ 0.3 mm × 23 pcs

Measurement Result

(Ta = 25°C, Tjmax = 150°C)

Item	Measurement Result
Power Dissipation	2800 mW
Thermal Resistance (θ_{ja})	$\theta_{ja} = 44^\circ\text{C/W}$
Thermal Characterization Parameter (ψ_{jt})	$\psi_{jt} = 20^\circ\text{C/W}$

θ_{ja} : Junction-to-Ambient Thermal Resistance

ψ_{jt} : Junction-to-Top Thermal Characterization Parameter

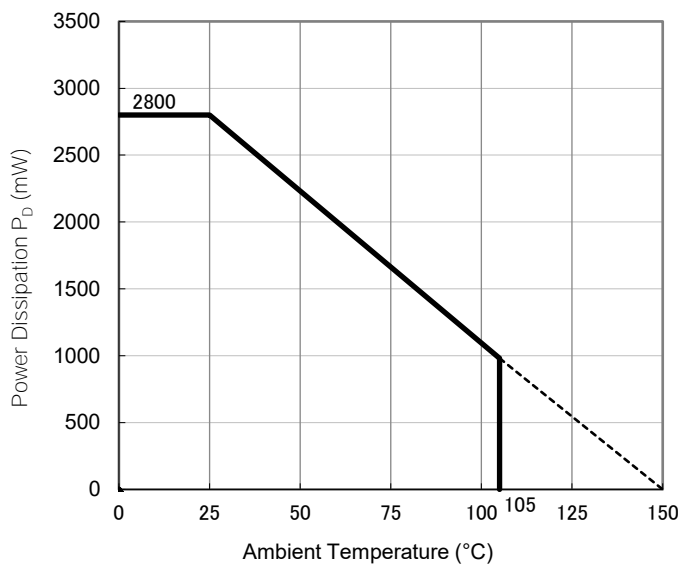

Power Dissipation vs. Ambient Temperature

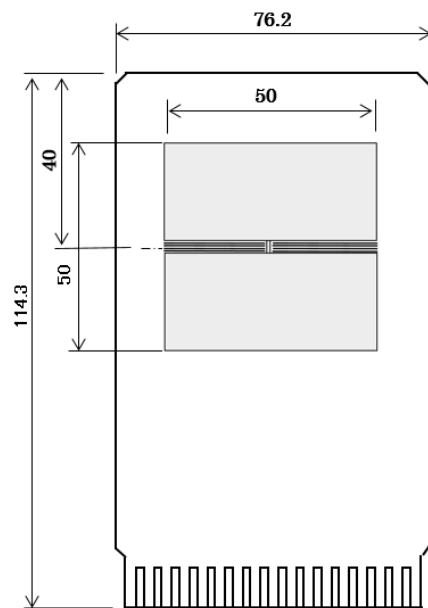

Measurement Board Pattern

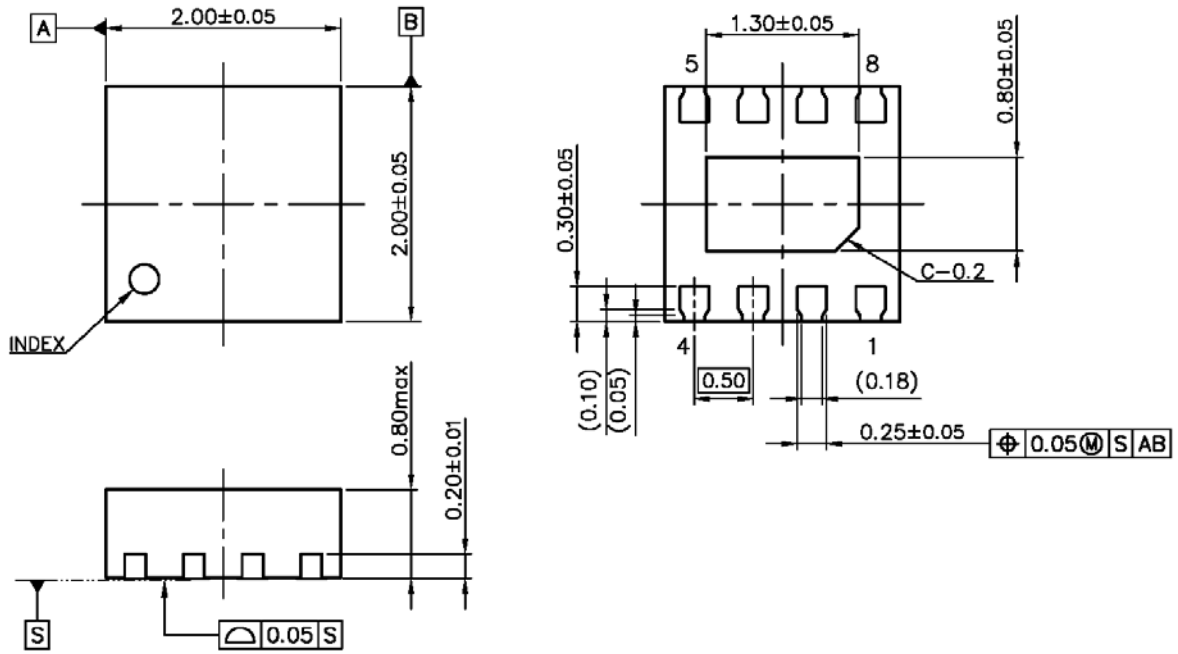

DFN2020-8B Package Dimensions (Unit: mm)

①②③④: Product Code ... Refer to *Part Marking List*

⑤⑥: Lot Number ... Alphanumeric Serial Number

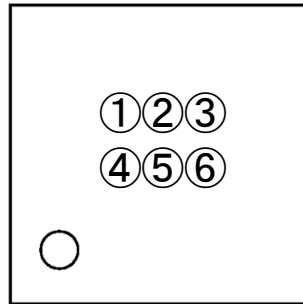

DFN2020-8B Part Markings

NOTICE

There can be variation in the marking when different AOI (Automated Optical Inspection) equipment is used. In the case of recognizing the marking characteristic with AOI, please contact our sales or our distributor before attempting to use AOI.

PART MARKINGS

RP115L

MK-RP115L-JCEC-D

RP115Lxx2x Part Marking List

Product Name	①	②	③	④
RP115L092B	E	W	0	9
RP115L102B	E	W	1	0
RP115L112B	E	W	1	1
RP115L122B	E	W	1	2
RP115L132B5	E	W	0	4
RP115L152B	E	W	1	5
RP115L182B	E	W	1	8
RP115L252B	E	W	2	5
RP115L282B	E	W	2	8
RP115L302B	E	W	3	0
RP115L332B	E	W	3	3
RP115L342B	E	W	3	4
RP115L392B	E	W	3	9
RP115L122B5	E	W	0	1
RP115L172B5	E	W	6	1

Product Name	①	②	③	④
RP115L092D	E	X	0	9
RP115L102D	E	X	1	0
RP115L112D	E	X	1	1
RP115L122D	E	X	1	2
RP115L132D5	E	X	0	4
RP115L152D	E	X	1	5
RP115L182D	E	X	1	8
RP115L252D	E	X	2	5
RP115L282D	E	X	2	8
RP115L302D	E	X	3	0
RP115L332D	E	X	3	3
RP115L342D	E	X	3	4
RP115L392D	E	X	3	9
RP115L122D5	E	X	0	1
RP115L172D5	E	X	6	1

The power dissipation of the package is dependent on PCB material, layout, and environmental conditions. The following measurement conditions are based on JEDEC STD. 51-7.

Measurement Conditions

Item	Measurement Conditions
Environment	Mounting on Board (Wind Velocity = 0 m/s)
Board Material	Glass Cloth Epoxy Plastic (Four-Layer Board)
Board Dimensions	76.2 mm × 114.3 mm × 0.8 mm
Copper Ratio	Outer Layer (First Layer): Less than 95% of 50 mm Square Inner Layers (Second and Third Layers): Approx. 100% of 50 mm Square Outer Layer (Fourth Layer): Approx. 100% of 50 mm Square
Through-holes	φ 0.3 mm × 13 pcs

Measurement Result

(Ta = 25°C, Tjmax = 150°C)

Item	Measurement Result
Power Dissipation	3200 mW
Thermal Resistance (θ_{ja})	$\theta_{ja} = 38^\circ\text{C/W}$
Thermal Characterization Parameter (ψ_{jt})	$\psi_{jt} = 13^\circ\text{C/W}$

θ_{ja} : Junction-to-Ambient Thermal Resistance

ψ_{jt} : Junction-to-Top Thermal Characterization Parameter

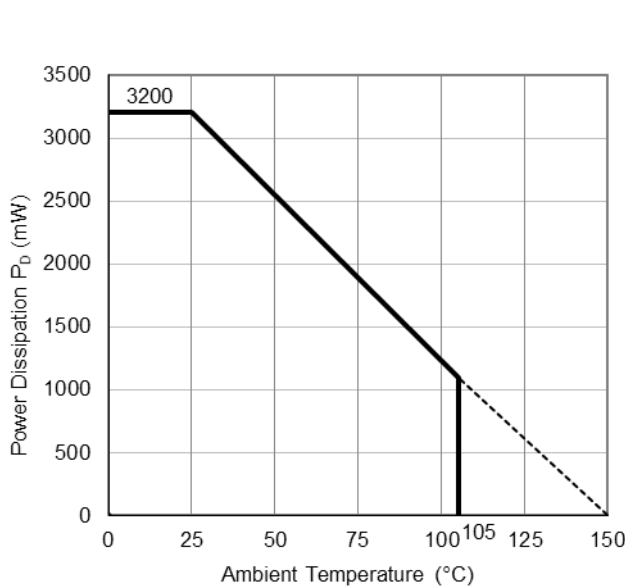

Power Dissipation vs. Ambient Temperature

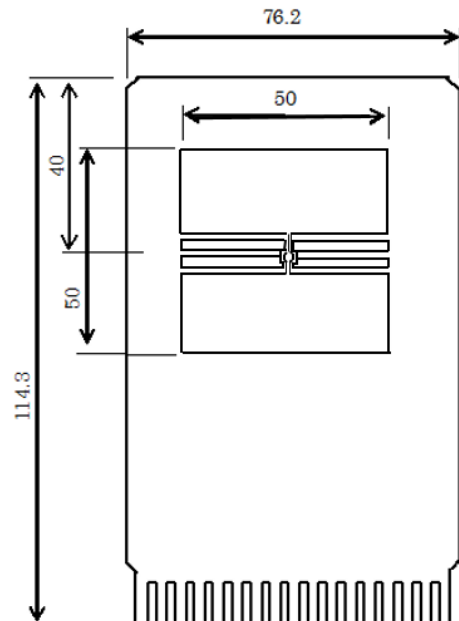

Measurement Board Pattern

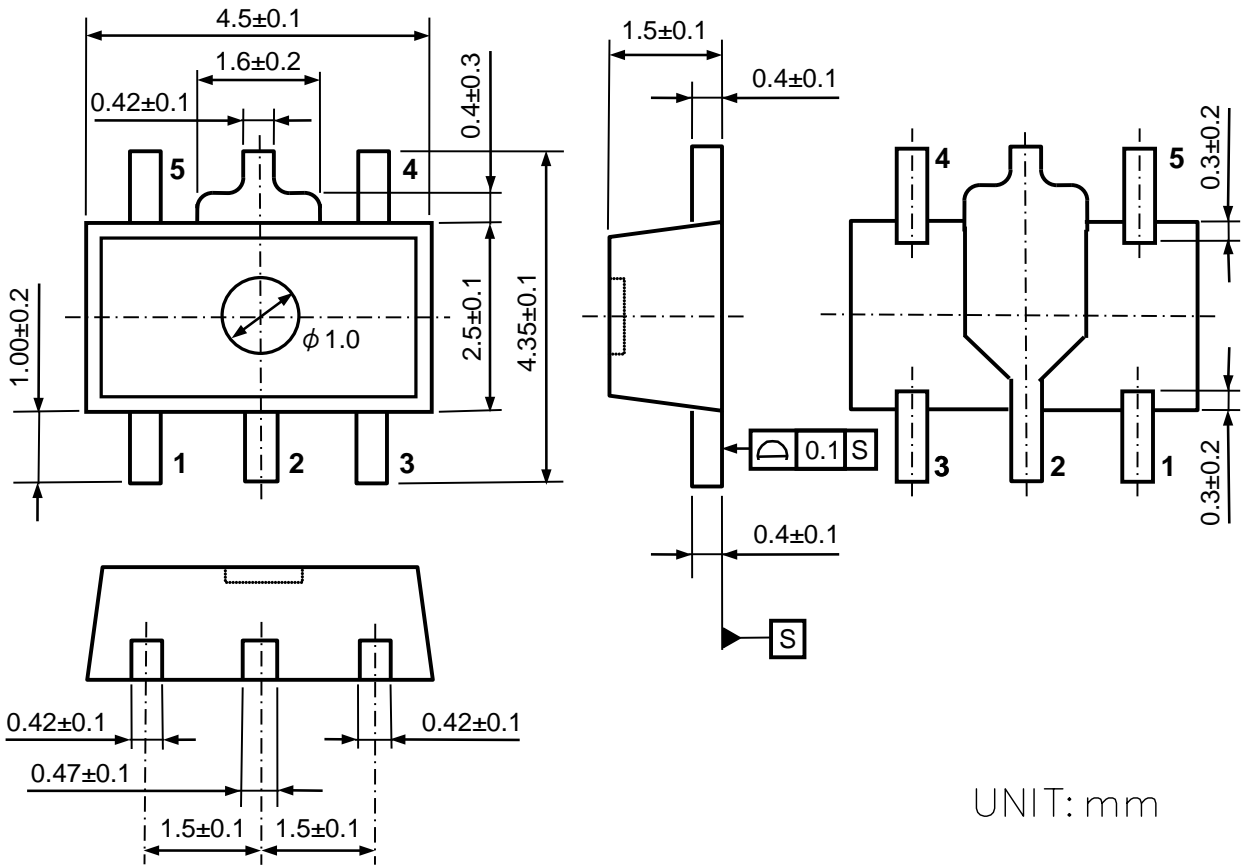

UNIT: mm

SOT-89-5 Package Dimensions

①②③④: Product Code ··· Refer to *Part Marking List*

⑤⑥: Lot Number ··· Alphanumeric Serial Number

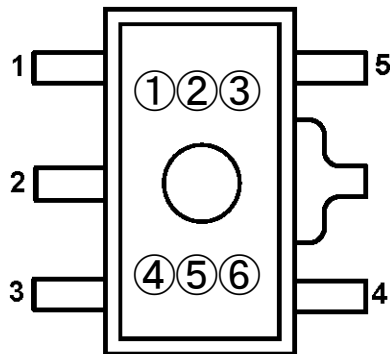

SOT-89-5 Part Markings

NOTICE

There can be variation in the marking when different AOI (Automated Optical Inspection) equipment is used. In the case of recognizing the marking characteristic with AOI, please contact our sales or our distributor before attempting to use AOI.

PART MARKINGS

RP115H

MK-RP115H-JCEC-D

RP115Hxx1x Part Marking List

Product Name	①	②	③	④
RP115H091B	D	0	9	F
RP115H101B	D	1	0	F
RP115H111B	D	1	1	F
RP115H121B	D	1	2	F
RP115H131B5	D	0	4	F
RP115H151B	D	1	5	F
RP115H181B	D	1	8	F
RP115H251B	D	2	5	F
RP115H281B	D	2	8	F
RP115H301B	D	3	0	F
RP115H331B	D	3	3	F
RP115H341B	D	3	4	F
RP115H391B	D	3	9	F
RP115H121B5	D	0	1	F

Product Name	①	②	③	④
RP115H091D	D	0	9	G
RP115H101D	D	1	0	G
RP115H111D	D	1	1	G
RP115H121D	D	1	2	G
RP115H131D5	D	0	4	G
RP115H151D	D	1	5	G
RP115H181D	D	1	8	G
RP115H251D	D	2	5	G
RP115H281D	D	2	8	G
RP115H301D	D	3	0	G
RP115H331D	D	3	3	G
RP115H341D	D	3	4	G
RP115H391D	D	3	9	G
RP115H121D5	D	0	1	G

1. The products and the product specifications described in this document are subject to change or discontinuation of production without notice for reasons such as improvement. Therefore, before deciding to use the products, please refer to our sales representatives for the latest information thereon.
2. The materials in this document may not be copied or otherwise reproduced in whole or in part without the prior written consent of us.
3. This product and any technical information relating thereto are subject to complementary export controls (so-called KNOW controls) under the Foreign Exchange and Foreign Trade Law, and related politics ministerial ordinance of the law. (Note that the complementary export controls are inapplicable to any application-specific products, except rockets and pilotless aircraft, that are insusceptible to design or program changes.) Accordingly, when exporting or carrying abroad this product, follow the Foreign Exchange and Foreign Trade Control Law and its related regulations with respect to the complementary export controls.
4. The technical information described in this document shows typical characteristics and example application circuits for the products. The release of such information is not to be construed as a warranty of or a grant of license under our or any third party's intellectual property rights or any other rights.
5. The products listed in this document are intended and designed for automotive applications. Those customers intending to use a product in an application requiring extreme quality and reliability, for example, in a highly specific application where the failure or misoperation of the product could result in human injury or death should first contact us.
 - Aerospace Equipment
 - Equipment Used in the Deep Sea
 - Power Generator Control Equipment (nuclear, steam, hydraulic, etc.)
 - Life Maintenance Medical Equipment
 - Fire Alarms / Intruder Detectors
 - Vehicle Control Equipment (airplane, railroad, ship, etc.)
 - Various Safety Devices
 - Traffic control system
 - Combustion equipment

In case your company desires to use this product for any applications other than general electronic equipment mentioned above, make sure to contact our company in advance. Note that the important requirements mentioned in this section are not applicable to cases where operation requirements such as application conditions are confirmed by our company in writing after consultation with your company.

6. We are making our continuous effort to improve the quality and reliability of our products, but semiconductor products are likely to fail with certain probability. In order to prevent any injury to persons or damages to property resulting from such failure, customers should be careful enough to incorporate safety measures in their design, such as redundancy feature, fire containment feature and fail-safe feature. We do not assume any liability or responsibility for any loss or damage arising from misuse or inappropriate use of the products.
7. The products have been designed and tested to function within controlled environmental conditions. Do not use products under conditions that deviate from methods or applications specified in this datasheet. Failure to employ the products in the proper applications can lead to deterioration, destruction or failure of the products. We shall not be responsible for any bodily injury, fires or accident, property damage or any consequential damages resulting from misuse or misapplication of the products.
8. **Quality Warranty**
 - 8-1. **Quality Warranty Period**

In the case of a product purchased through an authorized distributor or directly from us, the warranty period for this product shall be one (1) year after delivery to your company. For defective products that occurred during this period, we will take the quality warranty measures described in section 8-2. However, if there is an agreement on the warranty period in the basic transaction agreement, quality assurance agreement, delivery specifications, etc., it shall be followed.
 - 8-2. **Quality Warranty Remedies**

When it has been proved defective due to manufacturing factors as a result of defect analysis by us, we will either deliver a substitute for the defective product or refund the purchase price of the defective product.
Note that such delivery or refund is sole and exclusive remedies to your company for the defective product.
 - 8-3. **Remedies after Quality Warranty Period**

With respect to any defect of this product found after the quality warranty period, the defect will be analyzed by us. On the basis of the defect analysis results, the scope and amounts of damage shall be determined by mutual agreement of both parties. Then we will deal with upper limit in Section 8-2. This provision is not intended to limit any legal rights of your company.
9. Anti-radiation design is not implemented in the products described in this document.
10. The X-ray exposure can influence functions and characteristics of the products. Confirm the product functions and characteristics in the evaluation stage.
11. WLCSP products should be used in light shielded environments. The light exposure can influence functions and characteristics of the products under operation or storage.
12. Warning for handling Gallium and Arsenic (GaAs) products (Applying to GaAs MMIC, Photo Reflector). These products use Gallium (Ga) and Arsenic (As) which are specified as poisonous chemicals by law. For the prevention of a hazard, do not burn, destroy, or process chemically to make them as gas or power. When the product is disposed of, please follow the related regulation and do not mix this with general industrial waste or household waste.
13. Please contact our sales representatives should you have any questions or comments concerning the products or the technical information.



Nisshinbo Micro Devices Inc.

Official website

<https://www.nisshinbo-microdevices.co.jp/en/>

Purchase information

<https://www.nisshinbo-microdevices.co.jp/en/buy/>