

## Low Input Voltage 3 A LDO Regulator for High Temperature Applications

NO.EY-344-201216

### OUTLINE

The RP108J is a voltage regulator IC featuring 3 A output with low ON-resistance developed with CMOS process technology.

This device consists of a voltage reference unit, an error amplifier, resistor-net for voltage setting, a fold-back protection circuit, and a thermal shutdown circuit. This device features both low supply current and high output current, and the dropout voltage is much smaller than bi-polar's. The minimum input voltage is as low as 1.6 V and the output voltage can be set from 0.8 V, therefore it can be connected with the DC/DC converter as the latter power supply for high density LSI that is operated by low output voltage.

The output voltage of RP108J081x is externally adjustable by using external divide resistors. The CE pin of the RP108J can switch the regulator to standby mode. In addition to a fold-back protection circuit, which is already built in the conventional regulators, this device contains a thermal shutdown circuit, a constant slope circuit as a soft-start function and a reverse current protection circuit. Ceramic capacitors can be used.

### FEATURES

- Input Voltage Range (Maximum Rating) ..... 1.6 V to 5.25 V (6.0 V)
- Operating Temperature..... -40°C to 105°C (※)
- Output Current..... Min. 3 A
- Supply Current..... Typ. 350  $\mu$ A
- Standby Current ..... Typ. 2  $\mu$ A
- Output Voltage Range ..... 0.8 V/1.2 V/1.5 V/1.8 V/2.5 V/3.0 V/3.3 V  
Contact our company sales representatives for other voltages. RP108J081x (Adjustable by using external divide resistors): 0.8 V to 4.2 V
- Output Voltage Accuracy .....  $\pm 1.0\%$  ( $T_a = 25^\circ\text{C}$ )  
( $\pm 15$  mV accuracy, when  $V_{\text{SET}} \leq 1.5$  V)
- Output Voltage Temperature-drift Coefficient ..... Typ.  $\pm 100$  ppm/ $^\circ\text{C}$
- Ripple Rejection ..... Typ. 65 dB ( $f = 1$  kHz,  $V_{\text{SET}} = 2.5$  V)
- Dropout Voltage..... Typ. 0.51 V ( $V_{\text{SET}} = 2.5$  V)
- Line Regulation..... Typ. 0.1%/V
- Package..... TO-252-5-P2
- Built-in Fold-back Protection Circuit ..... Typ. 220 mA
- Built-in Thermal Shutdown Circuit..... Stops at 165°C
- Built-in Constant Slope Circuit
- Built-in Reverse Current Protection Circuit
- Ceramic capacitors are recommended to be used with this IC..... 10  $\mu$ F or more

※This product is usable for the high-temperature applications since have passed a test at the high temperature. In addition, this product has a high-reliability since having passed our rigorous quality standards. To distinguish from the consumer products, “-Yx” is added at the end of the product name.

### APPLICATIONS

- Industrial equipments such as FAs and smart meters
- Equipments used under high-temperature conditions
- Equipments accompanied by self-heating

## BLOCK DIAGRAMS

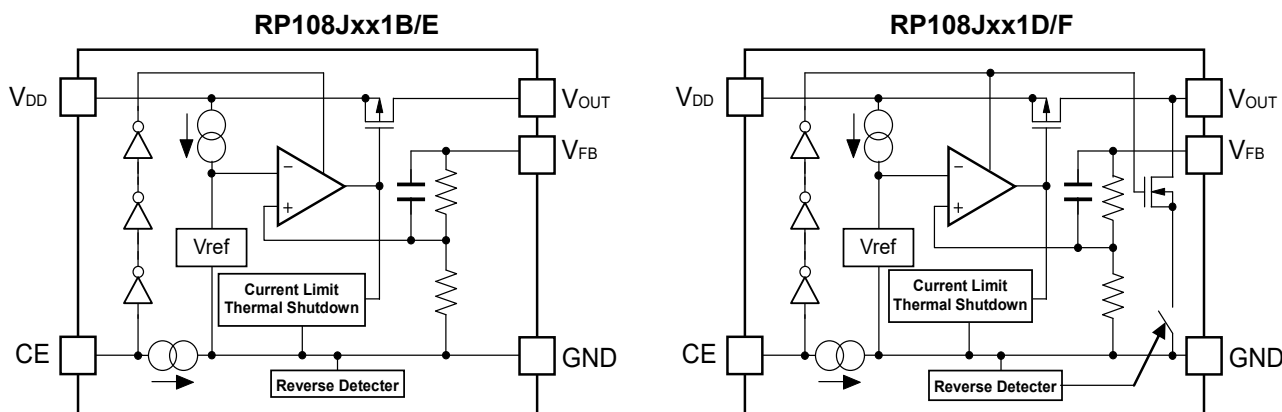

## SELECTION GUIDE

The output voltage and auto-discharge function, and the soft-start time for the device can be selected at the user's request.

Product Name	Package	Quantity per Reel	Pb Free	Halogen Free
RP108Jxx1*-T1-YE	TO-252-5-P2	3,000 pcs	Yes	Yes

xx: Specify the set output voltage ( $V_{SET}$ )  
 0.8 V (08), 1.2 V (12), 1.5 V (15), 1.8 V (18), 2.5 V (25), 3.0 V (30), 3.3 V (33)  
 Contact our company sales representatives for other voltages.

\* : Specify the auto-discharge function at off state and the soft-start time  
 (B) No auto-discharge function, soft start time typ. 180  $\mu$ s  
 (D) Auto-discharge function, soft start time typ. 180  $\mu$ s  
 (E) No auto-discharge function, soft start time typ. 570  $\mu$ s  
 (F) Auto-discharge function, soft start time typ. 570  $\mu$ s

Auto-discharge function quickly lowers the output voltage to 0 V by releasing the electrical charge in the external capacitor when the chip enable signal is switched from the active mode to the standby mode.

Refer to *CONSTANT SLOPE CIRCUIT* for detailed information on the difference of soft-start time and its effect.

## PIN DESCRIPTION

TO-252-5-P2

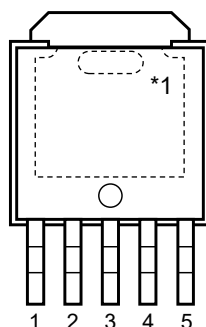

TO-252-5-P2

Pin No.	Symbol	Description
1	CE	Chip Enable Pin (Active-high)
2	V <sub>DD</sub>	Input Pin
3	GND	Ground Pin
4	V <sub>OUT</sub>	Output Pin
5	V <sub>FB</sub>	Feedback Pin

\*1 The tab on the bottom of the package enhances thermal performance and is electrically connected to GND (substrate level). It is recommended that the tab be connected to the ground plane on the board, or otherwise be left floating. The V<sub>OUT</sub> pin should be connected to the V<sub>FB</sub> pin when using RP108J as an internal fixed output voltage type. In case of using this device as an external adjustable type, refer to *Adjustable Output Voltage Type Settings* for detailed information.

## ABSOLUTE MAXIMUM RATINGS

Symbol	Item		Rating	Unit
V <sub>IN</sub>	Input Voltage		6.0	V
V <sub>CE</sub>	Input Voltage (CE Input Pin)		-0.3 to 6.0	V
V <sub>FB</sub>	Input Voltage (V <sub>FB</sub> Pin)		-0.3 to 6.0	V
V <sub>OUT</sub>	Output Voltage		-0.3 to V <sub>IN</sub> + 0.3	V
P <sub>D</sub>	Power Dissipation (TO-252-5-P2)*1	Standard Land Pattern	1900	mW
		Ultra High Wattage Land Pattern	3800	
T <sub>j</sub>	Junction Temperature		-40 to 125	°C
T <sub>stg</sub>	Storage Temperature		-55 to 125	°C

\*1 Refer to *PACKAGE INFORMATION* for detailed information.

### ABSOLUTE MAXIMUM RATINGS

Electronic and mechanical stress momentarily exceeded absolute maximum ratings may cause the permanent damages and may degrade the life time and safety for both device and system using the device in the field. The functional operation at or over these absolute maximum ratings is not assured.

## RECOMMENDED OPERATING CONDITIONS

Symbol	Item	Rating	Unit
V <sub>IN</sub>	Input Voltage*1	1.6 to 5.25	V
T <sub>a</sub>	Operating Temperature Range	-40 to 105	°C

\*1 In case of exceeding the maximum Input Voltage of 5.25 V, the device must be operated on condition that the Input Voltage is up to 5.5 V and the total operating time is within 500 hrs.

### RECOMMENDED OPERATING CONDITIONS

All of electronic equipment should be designed that the mounted semiconductor devices operate within the recommended operating conditions. The semiconductor devices cannot operate normally over the recommended operating conditions, even if when they are used over such ratings by momentary electronic noise or surge. And the semiconductor devices may receive serious damage when they continue to operate over the recommended operating conditions.

## ELECTRICAL CHARACTERISTICS

$V_{IN} = V_{SET} + 1.0\text{ V}$ ,  $I_{OUT} = 1\text{ mA}$ ,  $C_{IN} = C_{OUT} = 10\text{ }\mu\text{F}$ , unless otherwise noted.

The specifications surrounded by   are guaranteed by design engineering at  $-40^{\circ}\text{C} \leq T_a \leq 105^{\circ}\text{C}$ .

### RP108Jxx1B/D/E/F

( $T_a = 25^{\circ}\text{C}$ )

Symbol	Item	Conditions	Min.	Typ.	Max.	Unit	
$V_{OUT}$	Output voltage	$T_a = 25^{\circ}\text{C}$	$V_{SET} > 1.5\text{ V}$	$\times 0.99$		$\times 1.01$	V
			$V_{SET} \leq 1.5\text{ V}$	-15		15	mV
		$-40^{\circ}\text{C} \leq T_a \leq 105^{\circ}\text{C}$	$V_{SET} > 1.5\text{ V}$	<span style="border: 1px solid black; padding: 0 2px;"><math>\times 0.97</math></span>		<span style="border: 1px solid black; padding: 0 2px;"><math>\times 1.024</math></span>	V
			$V_{SET} \leq 1.5\text{ V}$	<span style="border: 1px solid black; padding: 0 2px;">-45</span>		<span style="border: 1px solid black; padding: 0 2px;">36</span>	mV
$I_{LIM}$	Output Current		<span style="border: 1px solid black; padding: 0 2px;">3.0</span>			A	
$\frac{\Delta V_{OUT}}{\Delta I_{OUT}}$	Load regulation	$1\text{ mA} \leq I_{OUT} \leq 300\text{ mA}$	<span style="border: 1px solid black; padding: 0 2px;">-15</span>	2.0	<span style="border: 1px solid black; padding: 0 2px;">20</span>	mV	
		$1\text{ mA} \leq I_{OUT} \leq 3000\text{ mA}$	<span style="border: 1px solid black; padding: 0 2px;">-70</span>	3.0	<span style="border: 1px solid black; padding: 0 2px;">50</span>		
$V_{DIF}$	Dropout Voltage	$I_{OUT} = 3000\text{ mA}$	Refer to the <i>Product-specific Electrical Characteristics</i>				
$I_{SS}$	Supply Current	$I_{OUT} = 0\text{ mA}$		350	<span style="border: 1px solid black; padding: 0 2px;">500</span>	$\mu\text{A}$	
$I_{standby}$	Standby Current	$V_{CE} = 0\text{ V}$		2.0	5.0	$\mu\text{A}$	
$\frac{\Delta V_{OUT}}{\Delta V_{IN}}$	Line regulation	$V_{SET} + 0.5\text{ V} \leq V_{IN} \leq 5.25\text{ V}$ , $I_{OUT} = 1\text{ mA}$ (When $V_{SET} \leq 1.1\text{ V}$ , $V_{IN} = 1.6\text{ V}$ )		0.10	<span style="border: 1px solid black; padding: 0 2px;">0.15</span>	%/V	
$I_{SC}$	Short Current Limit	$V_{OUT} = 0\text{ V}$		220		mA	
$I_{PD}$	CE Pull-down Current			0.3	<span style="border: 1px solid black; padding: 0 2px;">0.7</span>	$\mu\text{A}$	
$V_{CEH}$	CE Input Voltage "H"		<span style="border: 1px solid black; padding: 0 2px;">1.0</span>			V	
$V_{CEL}$	CE Input Voltage "L"				<span style="border: 1px solid black; padding: 0 2px;">0.4</span>	V	
$T_{TSD}$	Thermal Shutdown Temperature	Junction Temperature		165		$^{\circ}\text{C}$	
$T_{TSR}$	Thermal Shutdown Released Temperature	Junction Temperature		95		$^{\circ}\text{C}$	
$R_{LOW}$	Low Output Nch Tr. ON Resistance (of D/F version)	$V_{IN} = 4.0\text{ V}$ , $V_{CE} = 0\text{ V}$		30		$\Omega$	
$I_{REV}$	Reverse Current Limit	$V_{OUT} > 0.5\text{ V}$ , $0 \leq V_{IN} \leq 5.25\text{ V}$		10		$\mu\text{A}$	

All test items listed under Electrical Characteristics are done under the pulse load condition ( $T_j \approx T_a = 25^{\circ}\text{C}$ ).

The specifications surrounded by   are guaranteed by design engineering at  $-40^{\circ}\text{C} \leq T_a \leq 105^{\circ}\text{C}$ .

**Product-specific Electrical Characteristics**

( $T_a = 25^{\circ}\text{C}$ )

Product Name	$V_{\text{OUT}}$ (V) ( $T_a = 25^{\circ}\text{C}$ )			$V_{\text{OUT}}$ (V) ( $-40^{\circ}\text{C} \leq T_a \leq 105^{\circ}\text{C}$ )			$V_{\text{DIF}}$ (V) ( $I_{\text{OUT}} = 3000 \text{ mA}$ )	
	MIN.	TYP.	MAX.	MIN.	TYP.	MAX.	TYP.	MAX.
RP108J081x	0.785	0.800	0.815	<span style="border: 1px solid black; padding: 0 2px;">0.755</span>	0.800	<span style="border: 1px solid black; padding: 0 2px;">0.836</span>	0.910	<span style="border: 1px solid black; padding: 0 2px;">1.155</span>
RP108J121x	1.185	1.200	1.215	<span style="border: 1px solid black; padding: 0 2px;">1.155</span>	1.200	<span style="border: 1px solid black; padding: 0 2px;">1.236</span>	0.720	<span style="border: 1px solid black; padding: 0 2px;">0.890</span>
RP108J151x	1.485	1.500	1.515	<span style="border: 1px solid black; padding: 0 2px;">1.455</span>	1.500	<span style="border: 1px solid black; padding: 0 2px;">1.536</span>	0.630	<span style="border: 1px solid black; padding: 0 2px;">0.790</span>
RP108J181x	1.782	1.800	1.818	<span style="border: 1px solid black; padding: 0 2px;">1.746</span>	1.800	<span style="border: 1px solid black; padding: 0 2px;">1.843</span>		
RP108J251x	2.475	2.500	2.525	<span style="border: 1px solid black; padding: 0 2px;">2.425</span>	2.500	<span style="border: 1px solid black; padding: 0 2px;">2.560</span>	0.510	<span style="border: 1px solid black; padding: 0 2px;">0.670</span>
RP108J301x	2.970	3.000	3.030	<span style="border: 1px solid black; padding: 0 2px;">2.910</span>	3.000	<span style="border: 1px solid black; padding: 0 2px;">3.072</span>		
RP108J331x	3.267	3.300	3.333	<span style="border: 1px solid black; padding: 0 2px;">3.201</span>	3.300	<span style="border: 1px solid black; padding: 0 2px;">3.379</span>	0.480	<span style="border: 1px solid black; padding: 0 2px;">0.590</span>

## TYPICAL APPLICATIONS

### Internally Fixed Output Voltage

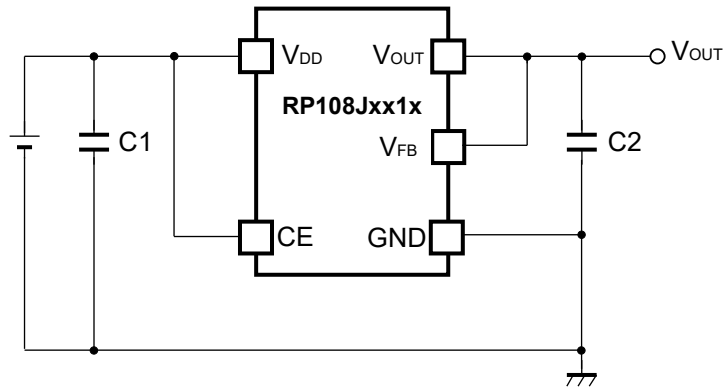

### Externally Adjustable Output Voltage

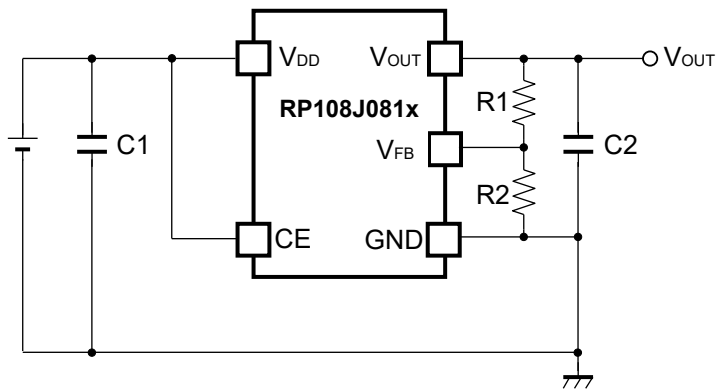

### External Components

Symbol	Description
C1 (C <sub>IN</sub> ), C2 (C <sub>OUT</sub> )	10 μF, Ceramic Capacitor, Kyocera CM21X7R106M06AB

## TECHNICAL NOTES

When using the RP108J, please consider the following points.

When using an internally fixed output voltage type, please connect the  $V_{OUT}$  pin to the  $V_{FB}$  pin. However, in the case of using the Adjustable Output Voltage Type, please follow the *Adjustable Output Voltage Setting*.

### Phase Compensation

In this device, phase compensation is made for securing stable operation even if the load current is varied. For this purpose, use a 10  $\mu$ F or more capacitor C2.

In case of using a tantalum capacitor, and its ESR is large, the output may be unstable. Therefore, select C2 carefully considering its frequency characteristics.

The recommended temperature characteristics for C1 and C2 capacitors are the followings.

- X7R Characteristics: Temperature range from  $-55^{\circ}\text{C}$  to  $125^{\circ}\text{C}$ , Capacitance change of  $\pm 15\%$

The recommended capacitor's tolerable voltage is twice as large as the voltage of use (C1: Input voltage, C2: Output voltage). The upper limit of the capacitance value for C2 is 100  $\mu$ F.

However, the increase of C2 leads to the increase of inrush current. Refer to *CONSTANT SLOPE CIRCUIT* for detailed information.

### PCB Layout

Make  $V_{DD}$  and GND lines sufficient. If their impedance is high, noise pickup or unstable operation may result.

Connect a capacitor C1 with a capacitance value as much as 10  $\mu$ F or more between  $V_{DD}$  and GND pin, and as close as possible to the pins.

Set external components, especially the output capacitor C2, as close as possible to the device, and make wiring as short as possible (Refer to *TYPICAL APPLICATION*).

### Transient Response

When using the Adjustable Output Voltage Type, the transient response could be affected by the external resistors. Evaluate the circuit taking the actual conditions of use into account.



## TYPICAL APPLICATION FOR IC CHIP BREAKDOWN PREVENTION

### Internally Fixed Output Voltage

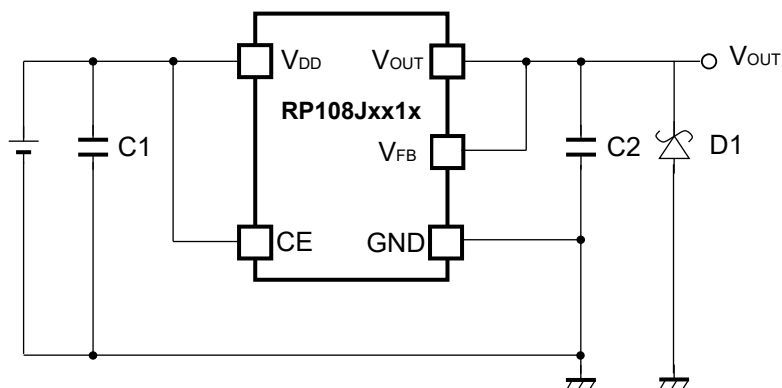

### Externally Adjustable Output Voltage

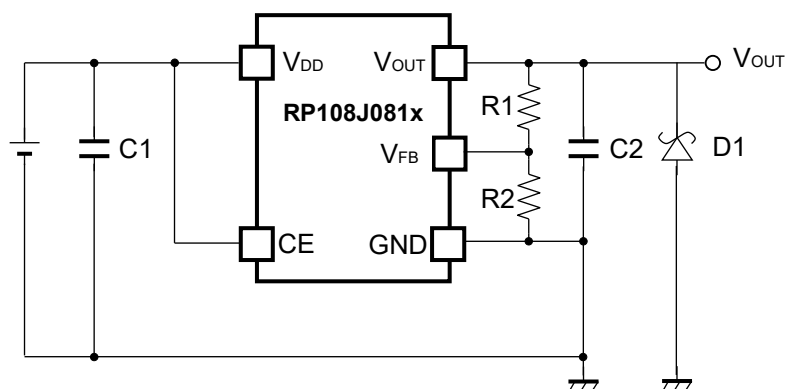

When a sudden surge of electrical current travels along the V<sub>OUT</sub> pin and GND due to a short-circuit, electrical resonance of a circuit involving an output capacitor (C2) and a short circuit inductor generates a negative voltage and may damage the device or the load devices. Connecting a schottky diode (D1) between the V<sub>OUT</sub> pin and GND has the effect of preventing damage to them.

## ADJUSTABLE OUTPUT VOLTAGE SETTING

### • Output Voltage Setting Method

RP108J081x is capable of adjusting the output voltage by using the external divider resistors.

If the  $V_{FB}$  voltage fixed in the device is described as  $setV_{FB}$ , the output voltage can be set by using the following equations.  $setV_{FB}$  is equal to 0.8 V. The  $V_{OUT}$  pin of RP108J081x should be connected to the  $V_{FB}$  pin.

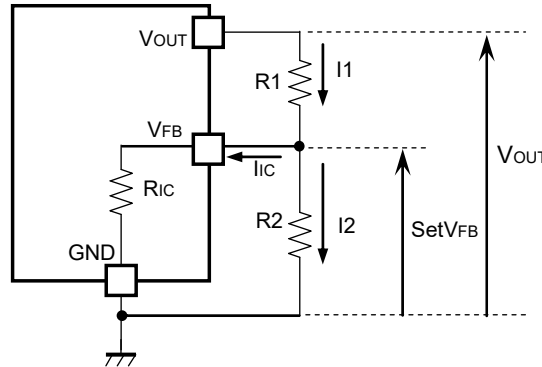

#### Adjustable Output Voltage Type Setting Using External Divider Resistors (R1, R2)

$$I1 = I_{IC} + I2 \dots\dots\dots (1)$$

$$I2 = setV_{FB} / R2 \dots\dots\dots (2)$$

Thus,

$$I1 = I_{IC} + setV_{FB} / R2 \dots\dots\dots (3)$$

Therefore,

$$V_{OUT} = setV_{FB} + R1 \times I1 \dots\dots\dots (4)$$

Put Equation (3) into Equation (4), then

$$\begin{aligned} V_{OUT} &= setV_{FB} + R1 (I_{IC} + setV_{FB} / R2) \\ &= setV_{FB} \times (1 + R1 / R2) + R1 \times I_{IC} \dots\dots\dots (5) \end{aligned}$$

In Equation (5),  $R1 \times I_{IC}$  is the error-causing factor in  $V_{OUT}$ .

As for  $I_{IC}$ ,

$$I_{IC} = setV_{FB} / R_{IC} \dots\dots\dots (6)$$

Therefore, the error-causing factor  $R1 \times I_{IC}$  can be described as follows.

$$\begin{aligned} R1 \times I_{IC} &= R1 \times setV_{FB} / R_{IC} \\ &= setV_{FB} \times R1 / R_{IC} \dots\dots\dots (7) \end{aligned}$$

For better accuracy, choosing  $R1 \ll R_{IC}$  reduces this error.

Without the error-causing factor  $R1 \times I_{IC}$ , the output voltage can be calculated by the following equation

$$V_{OUT} = setV_{FB} \times ((R1 + R2) / R2) \dots\dots\dots (8)$$

$R_{IC}$  of RP108J is approximately Typ.1.6 M $\Omega$  ( $T_a = 25^\circ C$ , this value is guaranteed by design).

The value could be affected by the temperature, therefore evaluate the circuit taking the actual conditions of use into account. The output voltage of the externally adjustable output voltage type should be set to 4.2 V or less. Also, total resistors value of  $R1$  and  $R2$  should be 20 k $\Omega$  or less.

## REVERSE CURRENT PROTECTION CIRCUIT

The RP108J includes a Reverse Current Protection Circuit, which stops the reverse current from  $V_{OUT}$  pin to  $V_{DD}$  pin or to GND pin when  $V_{OUT}$  becomes higher than  $V_{IN}$ .

Usually, the LDO using Pch output transistor contains a parasitic diode between  $V_{DD}$  pin and  $V_{OUT}$  pin. Therefore, if  $V_{OUT}$  is higher than  $V_{IN}$ , the parasitic diode becomes forward direction. As a result, the current flows from  $V_{OUT}$  pin to  $V_{DD}$  pin.

This device switches the mode to the reverse current protection mode before  $V_{IN}$  becomes lower than  $V_{OUT}$  by connecting the parasitic diode of Pch output transistor to the backward direction, and connecting the gate to  $V_{OUT}$  pin. As a result, the Pch output transistor is turned off and the all the current pathways from  $V_{OUT}$  pin to GND pin are shut down to maintain the reverse current lower than  $10\ \mu\text{A}$ .

Switching to either the normal mode or to the reverse current protection mode is determined by the magnitude of  $V_{IN}$  voltage and  $V_{OUT}$  voltage. For the stable operation, offset and hysteresis are set as the threshold. Offset is set to 30 mV (Typ. 25°C) and hysteresis is set to 5 mV (Typ. 25°C).

Therefore, the minimum dropout voltage under the small load current condition is restricted by the value of 35 mV (Typ. 25°C).

Fig. 1 and Fig. 2 show the diagrams of each mode, and Fig. 3 shows the load characteristics of each mode. When giving the  $V_{OUT}$  pin a constant-voltage and decreasing the  $V_{IN}$  voltage, the dropout voltage will become lower than 30 mV (Typ. 25°C). As a result, the reverse current protection starts to function to stop the load current. By increasing the dropout voltage higher than 35 mV (Typ. 25°C), the protection mode will be released to let the load current to flow. If the dropout voltage to be used is lower than 30 mV (Typ. 25°C), the detection and the release may be repeated.

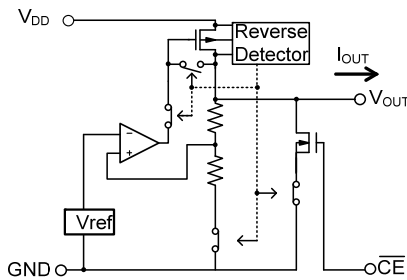

Fig. 1 Normal Mode

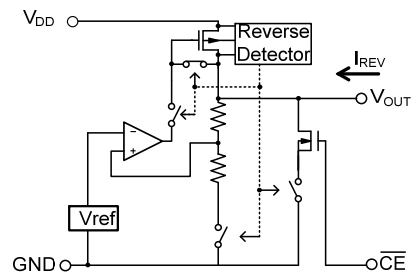

Fig. 2 Reverse Current Protection Mode

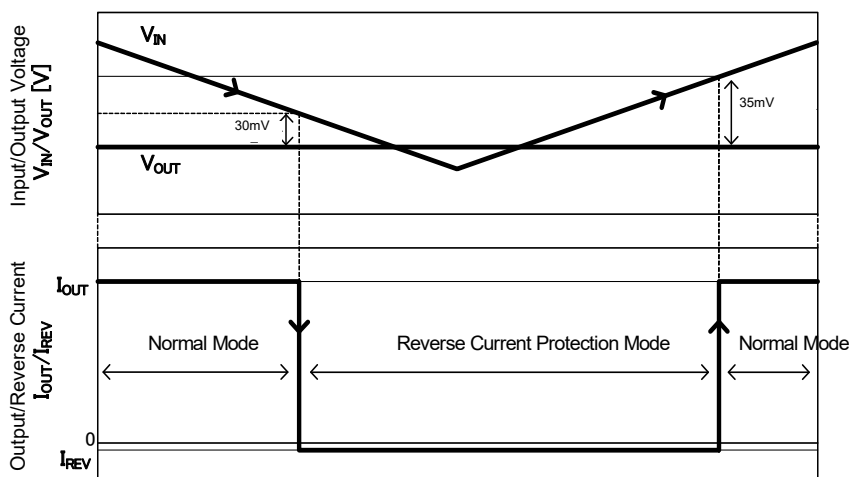

Fig. 3 Reverse Current Protection Mode Detection/ Release & Reverse Current/ Output Current Characteristics

## CONSTANT SLOPE CIRCUIT (RP108Jxx1B/xx1D)

RP108Jxx1B/xx1D has a Constant Slope Circuit (soft-start circuit) which allows the output voltage to start-up gradually. The capacitor to create the start-up slope is built-in the IC so that it does not require any external components. The upper limit of inrush current during the start-up is controlled by the short current ISC and the output current limit ILIM.

In the following characteristics  $C_{OUT} = 10 \mu\text{F}$  ( $R_{LOAD} = 380 \Omega$ ), the inrush current  $I_{RUSH}$  is not controlled by the short current ISC and the output current limit ILIM. Therefore the output voltage rises with the soft-start time ( $T_{SLOPE}$ ) set inside IC, and it enables to control the overshoot of the output voltage and the inrush current.  $T_{SLOPE}$  is typ. 180  $\mu\text{s}$ .

In the characteristics  $C_{OUT} = 20 \mu\text{F}$ ,  $I_{RUSH}$  at the low output voltage is controlled by the short current ISC. After the current is released from ISC, the output voltage rises with the soft-start time ( $T_{SLOPE}$ ).

In the characteristics  $C_{OUT} = 100 \mu\text{F}$ ,  $I_{RUSH}$  at the low output voltage is controlled by the short current ISC. After the current is released from ISC, it is controlled by the output current limit. The output voltage rises with the soft-start time ( $T_{SLOPE}$ ) or longer.

The relation of the inrush current and the constant slope depends on the output voltage since the inrush current is a sum of the charge current of  $C_{OUT}$  and the load current. Use RP108Jxx1E/xx1F to avoid an influence on peripheral components due to the inrush current generated in the use environment conditions ( $C_{OUT}$  and output voltage).

### RP108J381B/D Inrush current characteristics

Constant Slope Circuit  
(Diagrammatic sketch)

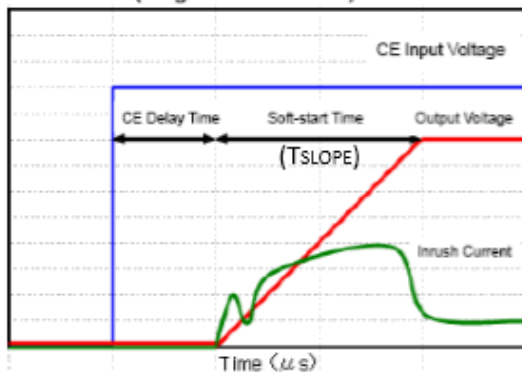

$C_{IN}=4.7\mu\text{F}$ ,  $C_{OUT}=10\mu\text{F}$ ,  $T_{opt}=25^\circ\text{C}$ ,  $R_{LOAD}=380\Omega$

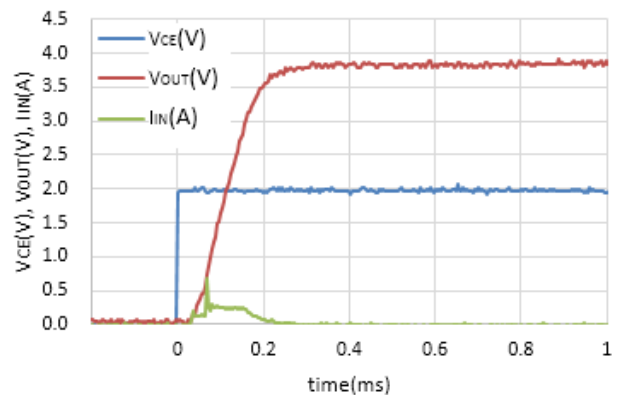

$C_{IN}=4.7\mu\text{F}$ ,  $C_{OUT}=20\mu\text{F}$ ,  $T_{opt}=25^\circ\text{C}$ ,  $R_{LOAD}=380\Omega$

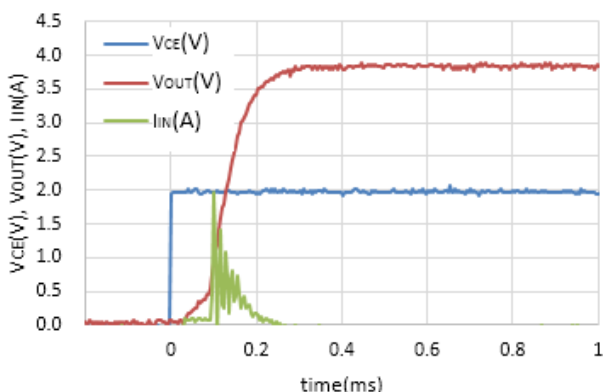

$C_{IN}=4.7\mu\text{F}$ ,  $C_{OUT}=100\mu\text{F}$ ,  $T_{opt}=25^\circ\text{C}$ ,  $R_{LOAD}=380\Omega$

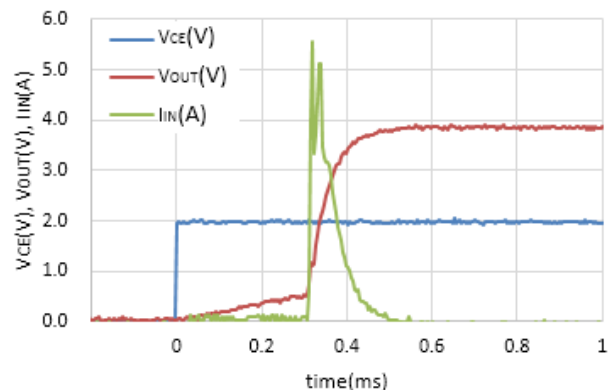

## CONSTANT SLOPE CIRCUIT (RP108Jxx1E/xx1F)

RP108Jxx1E/xx1F has a constant slope circuit (soft-start circuit) which allows the output voltage to start-up gradually. The capacitor to create the start-up slope is built-in the IC so that it does not require any external components. The upper limit of inrush current during the start-up is controlled by the output current limit  $I_{LIM}$ .

As shown in the following Foldback Characteristics, the inrush current is not controlled by the short current  $I_{SC}$  during the soft-start time at the start-up. Therefore the output voltage rises with the soft-start time ( $T_{SLOPE}$ ) set inside IC, and it enables to control the overshoot of the output voltage and the inrush current.  $T_{SLOPE}$  is typ. 570  $\mu s$  (max. 900  $\mu s/85^{\circ}C$ ). Use RP108Jxx1B/xx1D to avoid an influence on peripheral components due to the output start-up time is slow in the system.

In the characteristics  $C_{OUT} = 20 \mu F$ , the inrush current is lower or equal to the output current limit  $I_{LIM}$ . The output voltage rises with the soft-start time ( $T_{SLOPE}$ ).

Similarly in the characteristics  $C_{OUT} = 100 \mu F$ , the inrush current is lower or equal to the output current limit  $I_{LIM}$ . The output voltage rises with the soft-start time ( $T_{SLOPE}$ ).

The relation of the inrush current and the constant slope depends on the output voltage since the inrush current is a sum of the charge current of  $C_{OUT}$  and the load current.

### RP108J381E/F Inrush current characteristics

**Constant Slope Circuit**  
(Diagrammatic sketch)

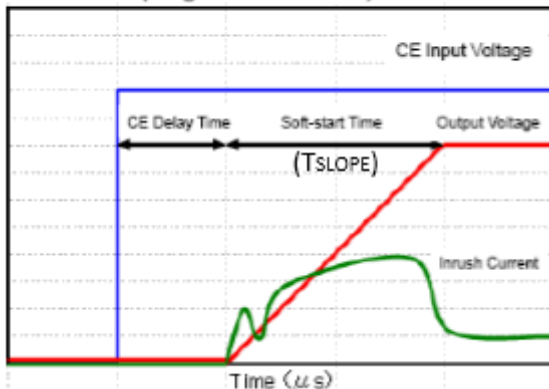

**Foldback Characteristics**  
(Diagrammatic sketch)

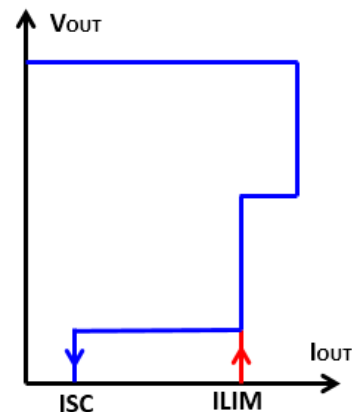

$C_{IN}=4.7\mu F, C_{OUT}=20\mu F, T_{opt}=25^{\circ}C, R_{LOAD}=380\Omega$

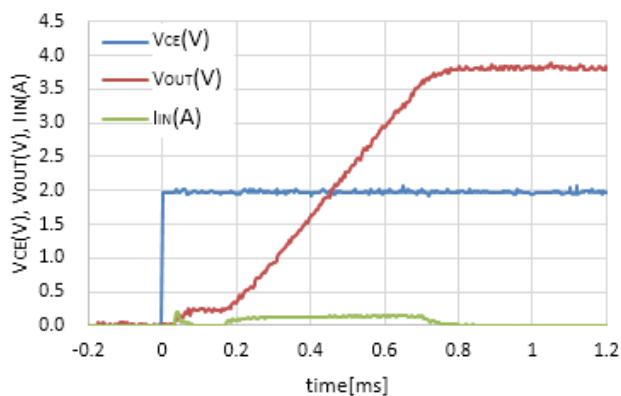

$C_{IN}=4.7\mu F, C_{OUT}=100\mu F, T_{opt}=25^{\circ}C, R_{LOAD}=380\Omega$

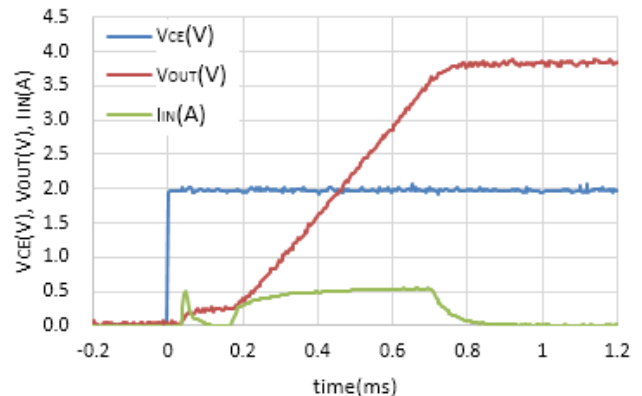

# PACKAGE INFORMATION

## POWER DISSIPATION (TO-252-5-P2)

Power Dissipation ( $P_D$ ) depends on conditions of mounting on board.  
This specification is based on the measurement at the condition below:

\* Measurement conditions

	Standard Land Pattern	Ultra High Wattage Land Pattern
Environment	Mounting on board (Wind velocity 0 m/s)	
Board Material	Glass cloth epoxy plastic (Double layers)	Glass cloth epoxy plastic (Four-layers)
Board Dimensions	50 mm x 50 mm x 1.6 mm	76.2 mm x 114.3 mm x 0.8 mm
Copper Ratio	Top side: Approx. 50%, Back side: Approx. 50%	Top, Back side: Approx. 96%, 2nd, 3rd: 100%
Through - hole	$\phi$ 0.5 mm x 24 pcs	$\phi$ 0.4 mm x 30 pcs

\* Measurement Results

( $T_a = 25^\circ\text{C}$ ,  $T_{j\text{max}} = 125^\circ\text{C}$ )

	Standard Land Pattern	Ultra High Wattage Land Pattern
Power Dissipation	1900 mW	3800 mW
Thermal Resistance	$\theta_{ja} = (125-25^\circ\text{C})/1.9 \text{ W} = 53^\circ\text{C/W}$	$\theta_{ja} = (125-25^\circ\text{C})/3.8 \text{ W} = 26^\circ\text{C/W}$
	$\theta_{jc} = 17^\circ\text{C/W}$	$\theta_{jc} = 7^\circ\text{C/W}$

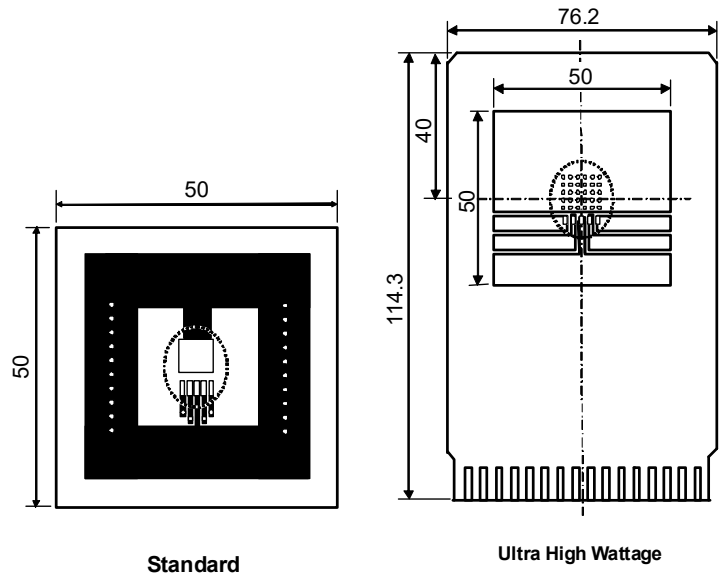
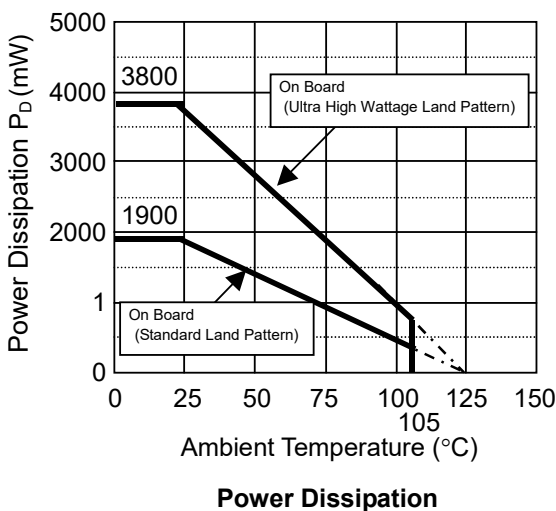

Measurement Board Pattern

IC Mount Area (Unit : mm)

PACKAGE DIMENSIONS (TO-252-5-P2)

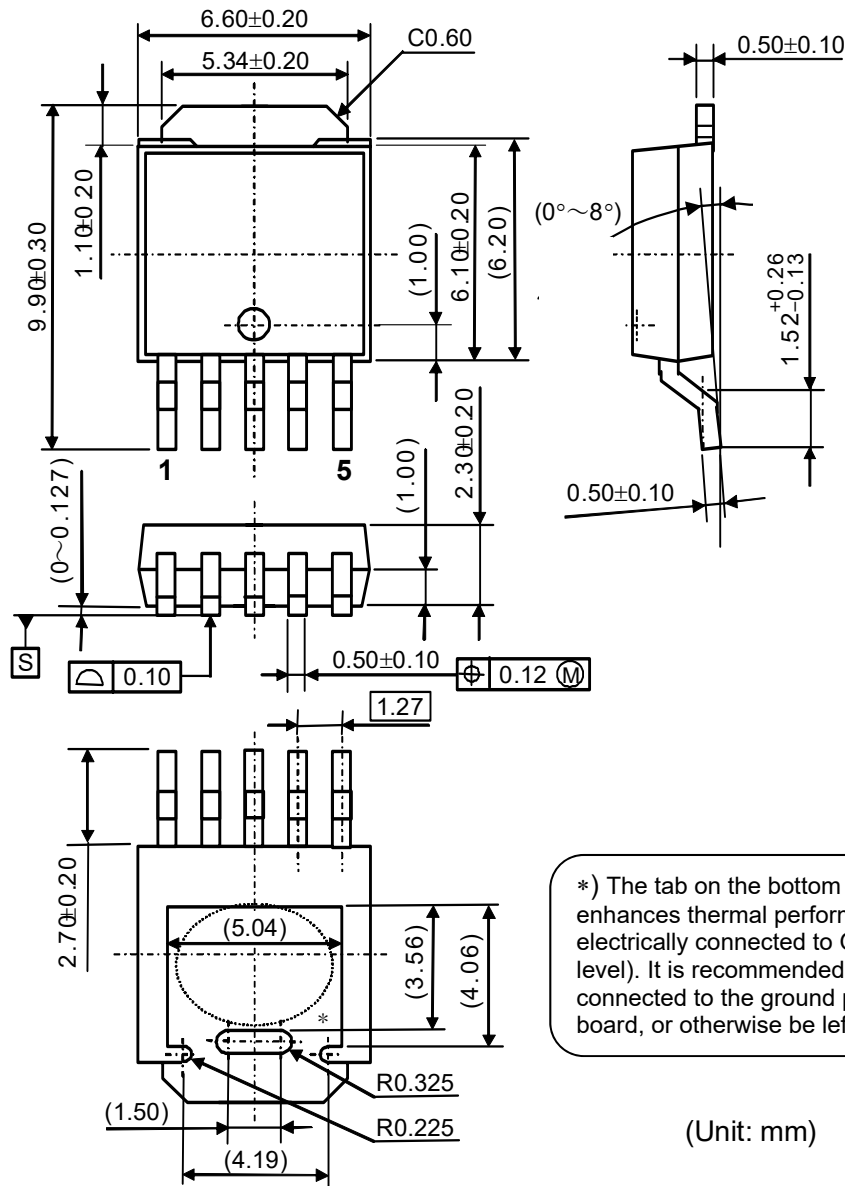

MARK SPECIFICATION (TO-252-5-P2)

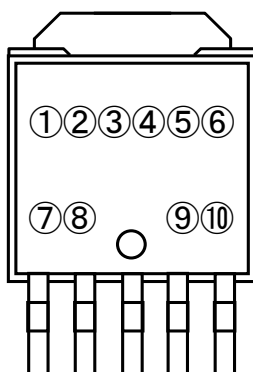

①②③④⑤⑥⑦⑧: Product Code... **Refer to MARK SPECIFICATION TABLE**

⑨⑩: Lot Number ... Alphanumeric Serial Number

**MARK SPECIFICATION TABLE (TO-252-5-P2)**

**RP108Jxx1B**

Product Name	①②③④⑤⑥⑦⑧	V <sub>SET</sub>
RP108J081B	<b>E 1 J 0 8 1 B</b>	0.8 V
RP108J121B	<b>E 1 J 1 2 1 B</b>	1.2 V
RP108J151B	<b>E 1 J 1 5 1 B</b>	1.5 V
RP108J181B	<b>E 1 J 1 8 1 B</b>	1.8 V
RP108J251B	<b>E 1 J 2 5 1 B</b>	2.5 V
RP108J301B	<b>E 1 J 3 0 1 B</b>	3.0 V
RP108J331B	<b>E 1 J 3 3 1 B</b>	3.3 V

**RP108Jxx1D**

Product Name	①②③④⑤⑥⑦⑧	V <sub>SET</sub>
RP108J081D	<b>E 1 J 0 8 1 D</b>	0.8 V
RP108J121D	<b>E 1 J 1 2 1 D</b>	1.2 V
RP108J151D	<b>E 1 J 1 5 1 D</b>	1.5 V
RP108J181D	<b>E 1 J 1 8 1 D</b>	1.8 V
RP108J251D	<b>E 1 J 2 5 1 D</b>	2.5 V
RP108J301D	<b>E 1 J 3 0 1 D</b>	3.0 V
RP108J331D	<b>E 1 J 3 3 1 D</b>	3.3 V

**RP108Jxx1E**

Product Name	①②③④⑤⑥⑦⑧	V <sub>SET</sub>
RP108J081E	<b>E 1 J 0 8 1 E</b>	0.8V
RP108J121E	<b>E 1 J 1 2 1 E</b>	1.2V
RP108J151E	<b>E 1 J 1 5 1 E</b>	1.5V
RP108J181E	<b>E 1 J 1 8 1 E</b>	1.8V
RP108J251E	<b>E 1 J 2 5 1 E</b>	2.5V
RP108J301E	<b>E 1 J 3 0 1 E</b>	3.0V
RP108J331E	<b>E 1 J 3 3 1 E</b>	3.3V

**RP108Jxx1F**

Product Name	①②③④⑤⑥⑦⑧	V <sub>SET</sub>
RP108J081F	<b>E 1 J 0 8 1 F</b>	0.8V
RP108J121F	<b>E 1 J 1 2 1 F</b>	1.2V
RP108J151F	<b>E 1 J 1 5 1 F</b>	1.5V
RP108J181F	<b>E 1 J 1 8 1 F</b>	1.8V
RP108J251F	<b>E 1 J 2 5 1 F</b>	2.5V
RP108J301F	<b>E 1 J 3 0 1 F</b>	3.0V
RP108J331F	<b>E 1 J 3 3 1 F</b>	3.3V



## TEST CIRCUITS

### Internally Fixed Output Voltage (RP108Jxx1x)

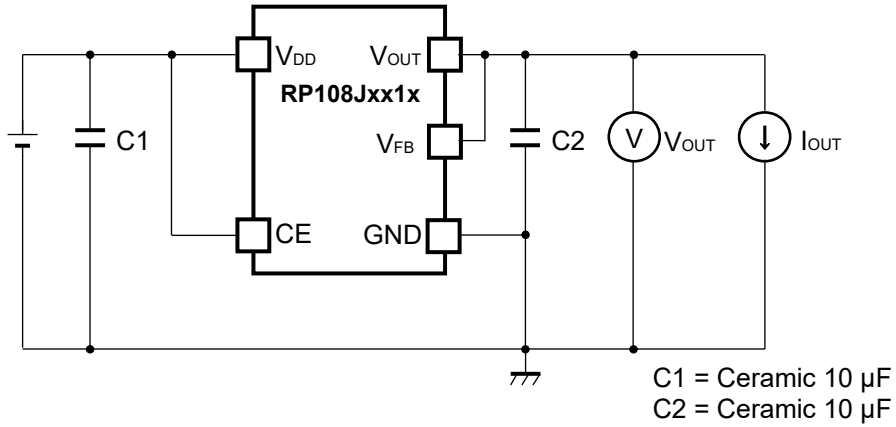

Basic Test Circuit

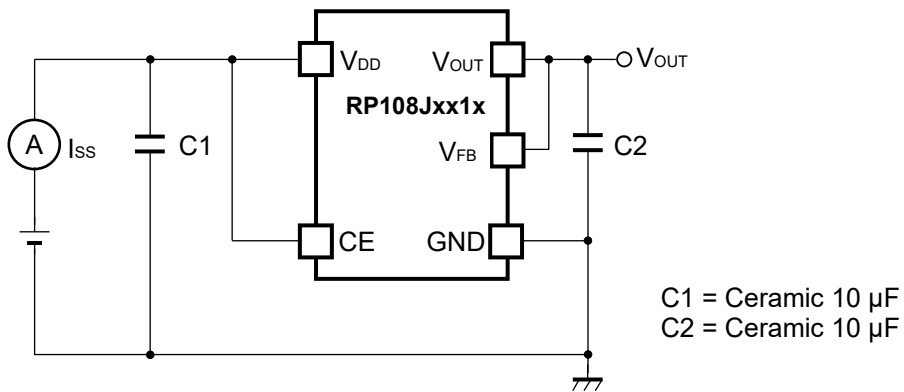

Test Circuit for Supply Current

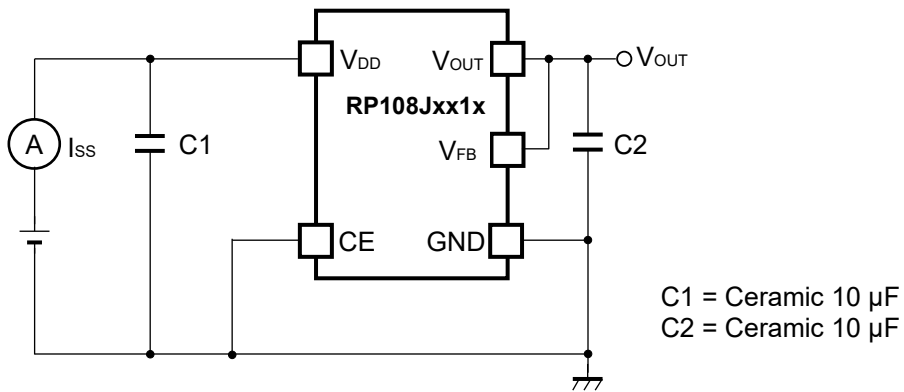

Test Circuit for Standby Current

**Externally Adjustable Output Voltage (RP108J081x)**

Refer to *Adjustable Output Voltage Setting* when using R1 and R2 as output resistors.

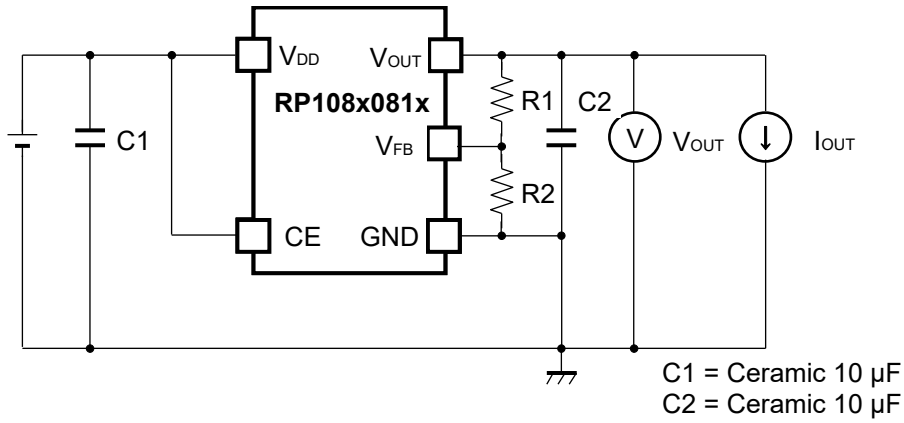

**Basic Test Circuit**

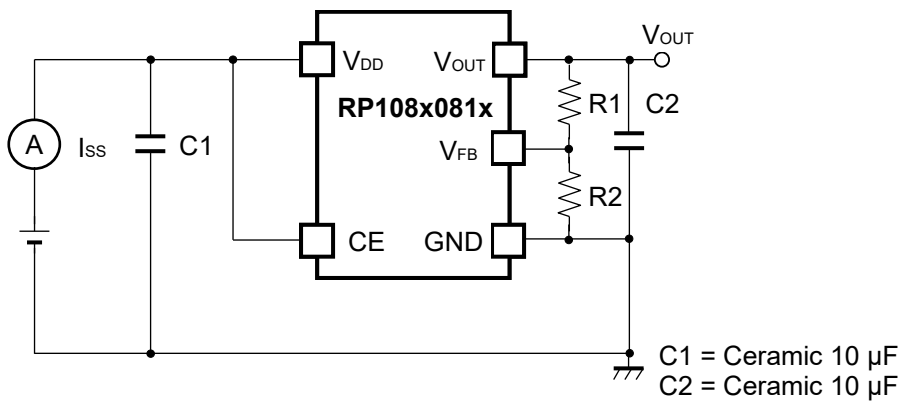

**Test Circuit for Supply Current**

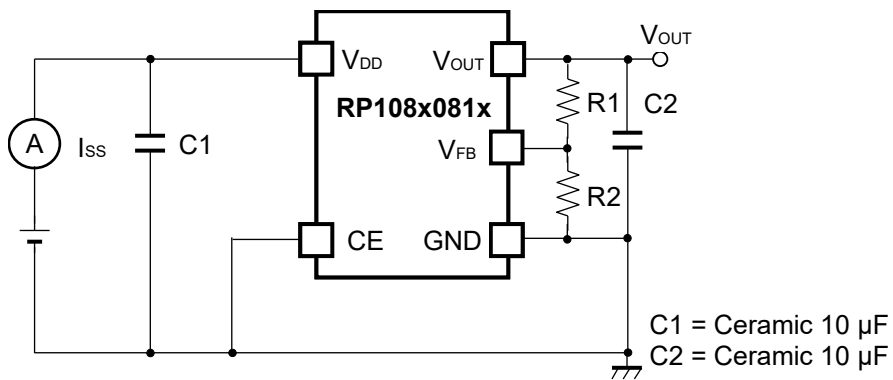

**Test Circuit for Standby Current**

## TYPICAL CHARACTERISTICS

Note: Typical Characteristics are intended to be used as reference data; they are not guaranteed.

### 1) Output Voltage vs. Input Voltage (C1 = Ceramic 10 $\mu$ F, C2 = Ceramic 10 $\mu$ F, Ta = 25°C)

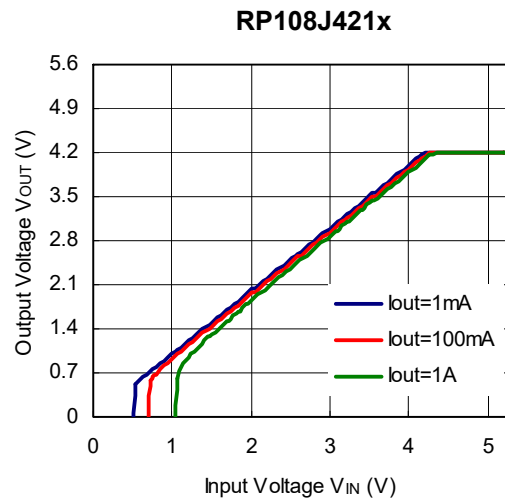
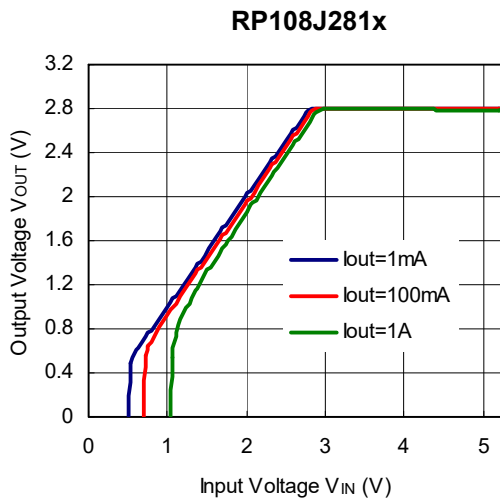
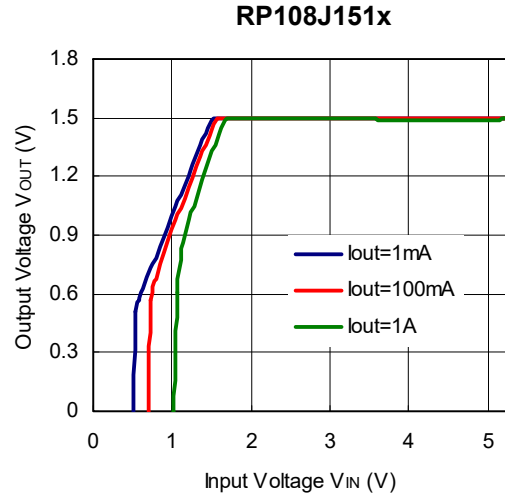
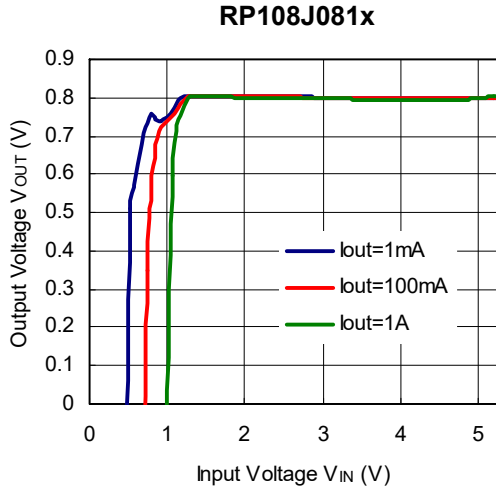

### 2) Output Voltage vs. Ambient Temperature (C1 = Ceramic 10 $\mu$ F, C2 = Ceramic 10 $\mu$ F, Ta = -40°C to 105°C)

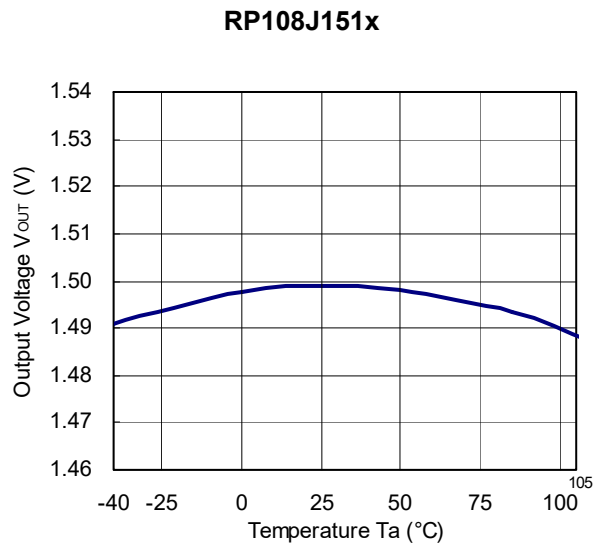
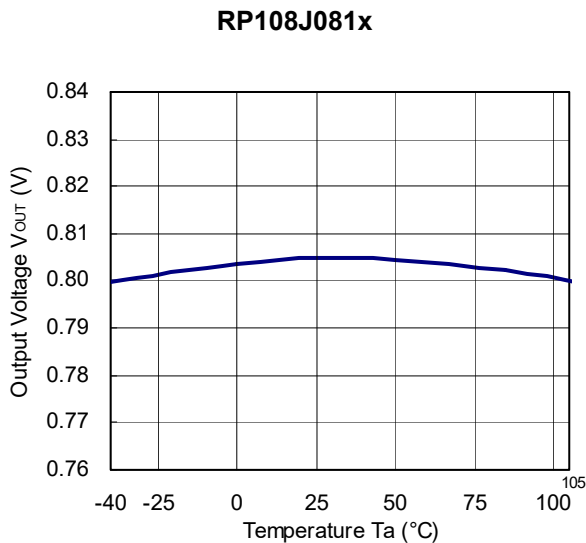

RP108J281x

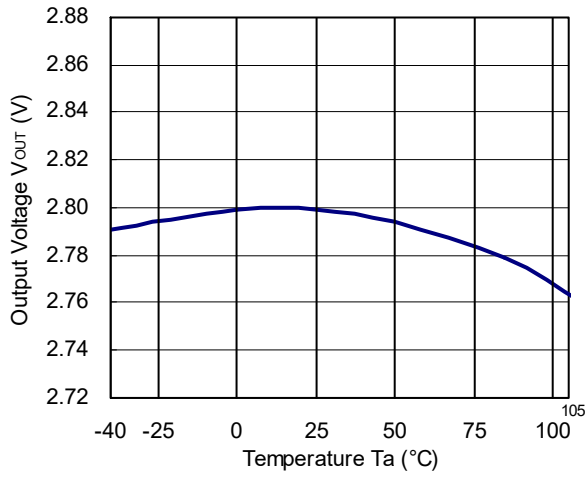

RP108J421x

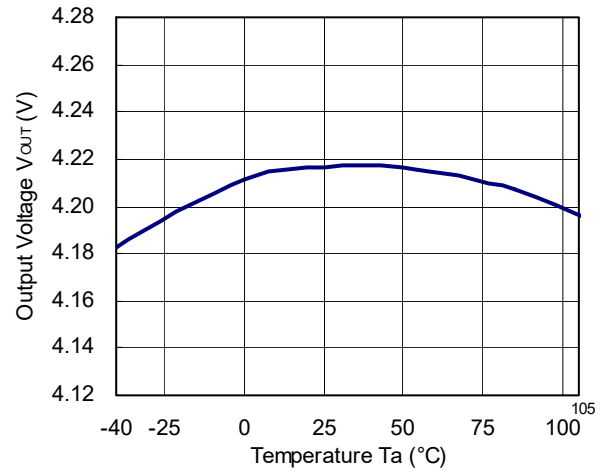

3) Supply Current vs. Input Voltage (C1 = Ceramic 10 μF, C2 = Ceramic 10 μF, I<sub>OUT</sub> = 0 mA, Ta = 25°C)

RP108J081x

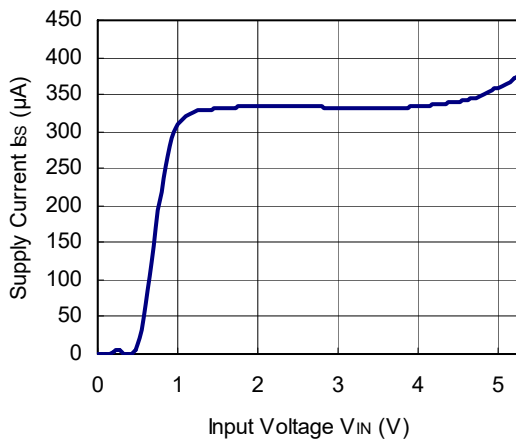

RP108J151x

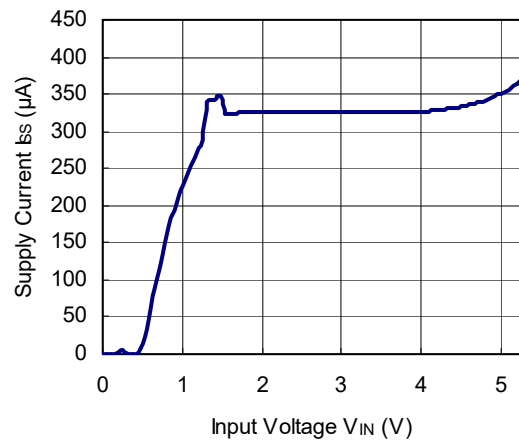

RP108J281x

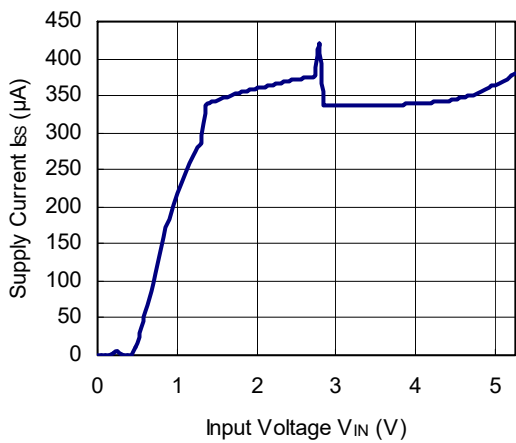

RP108J421x

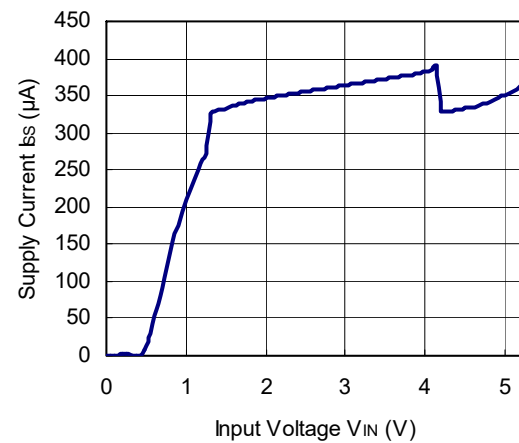

**4) Short Current Limit vs. Temperature/Current Limit vs. Temperature**

RP108J includes a Fold-back Protection Circuit, while a Fold-back Protection Circuit is operated, Thermal Shutdown Circuit starts to operate. Therefore RP108J is not allowed to test "Output voltage vs. Output Current" on condition that a Thermal Shutdown Circuit is operated to prevent heat generated by itself.

See the following graphs for short current limit and current limit characteristics.

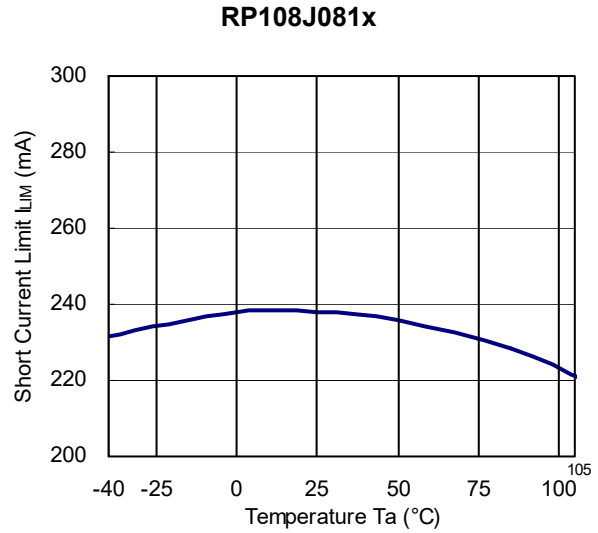
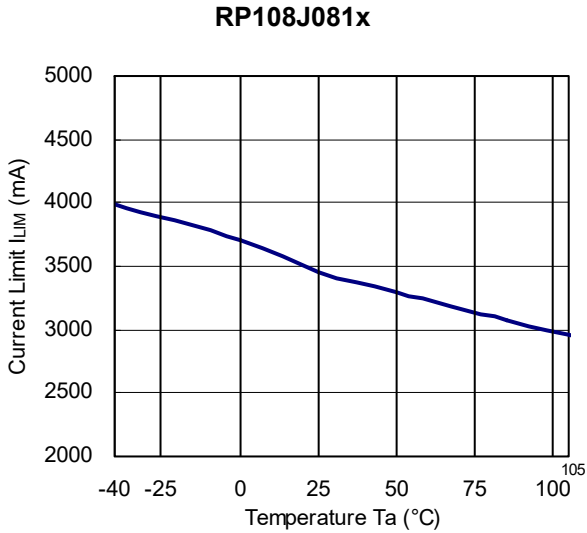

**5) Supply Current vs. Ambient Temperature (C1 = Ceramic 10 μF, C2 = Ceramic 10 μF, I<sub>OUT</sub> = 0 mA)**

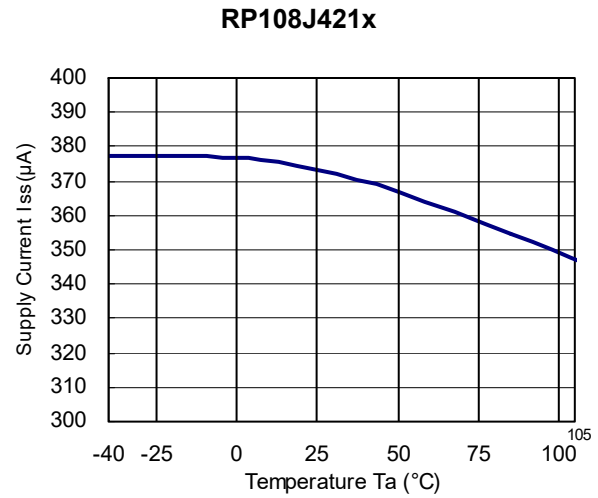
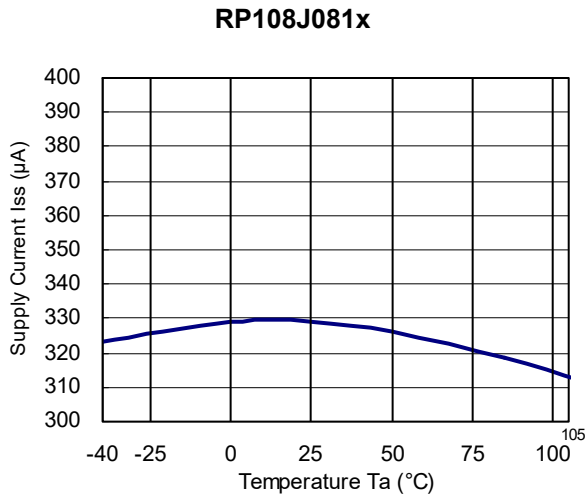

6) Dropout Voltage vs. Output Current (C1 = Ceramic 10  $\mu$ F, C2 = Ceramic 10  $\mu$ F)

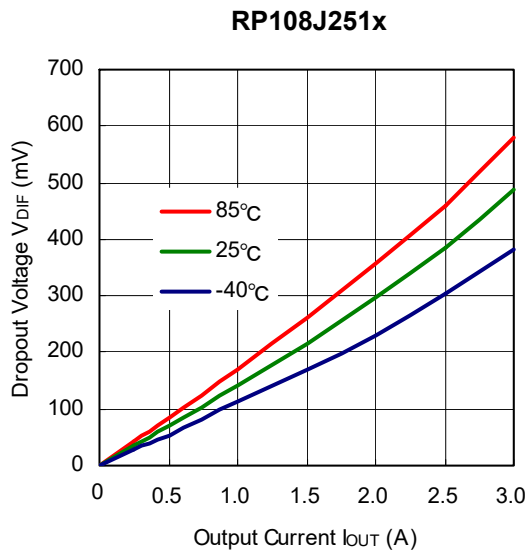

7) Dropout Voltage vs. Set Output Voltage (C1 = Ceramic 10  $\mu$ F, C2 = Ceramic 10  $\mu$ F,  $T_a = 25^\circ\text{C}$ )

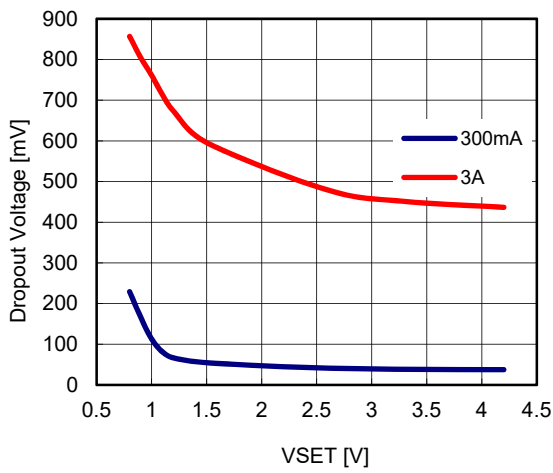

8) Ripple Rejection vs. Input Voltage (C1 = C2 = 10 μF, Ripple = 0.2 Vp-p, I<sub>OUT</sub> = 100 mA Ta = 25°C)

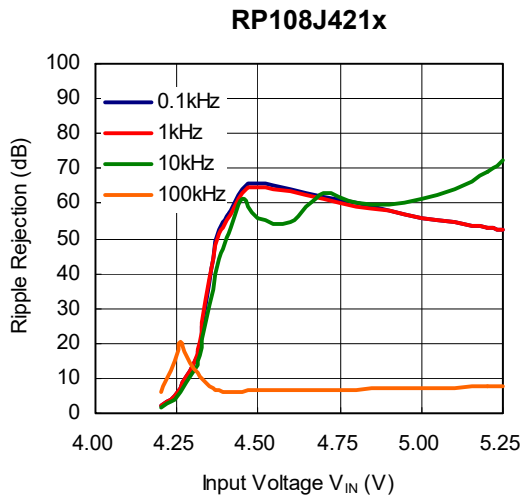
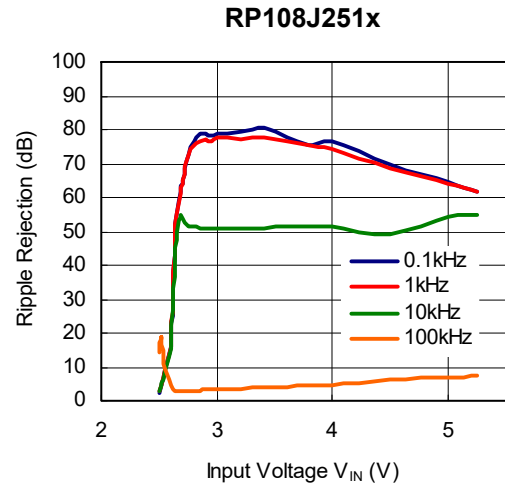
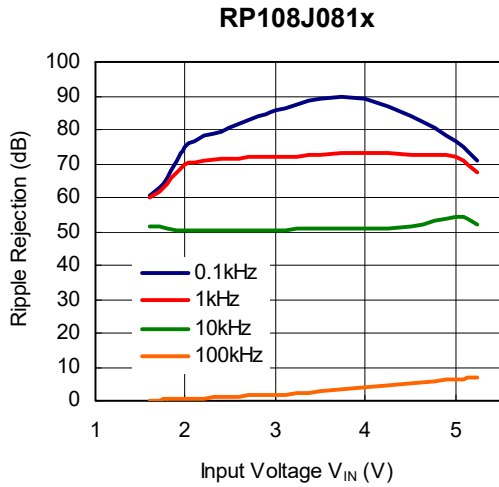

9) Ripple Rejection vs. Frequency (C1 = none, C2 = 10 μF, I<sub>OUT</sub> = 100 mA, Ta = 25°C)

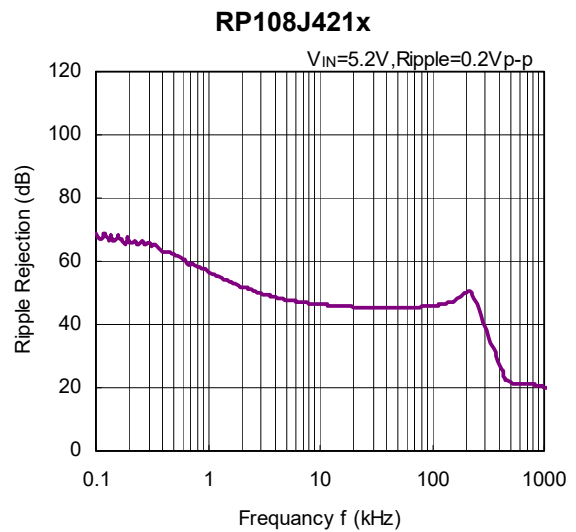
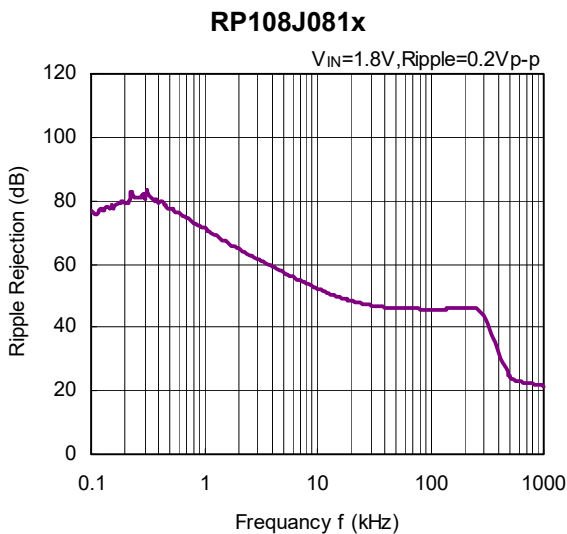

10) Input Transient Response (C1 = none, C2 = 10  $\mu$ F, I<sub>OUT</sub> = 30 mA, tr = tf = 5  $\mu$ s, Ta = 25°C)

RP108J081x

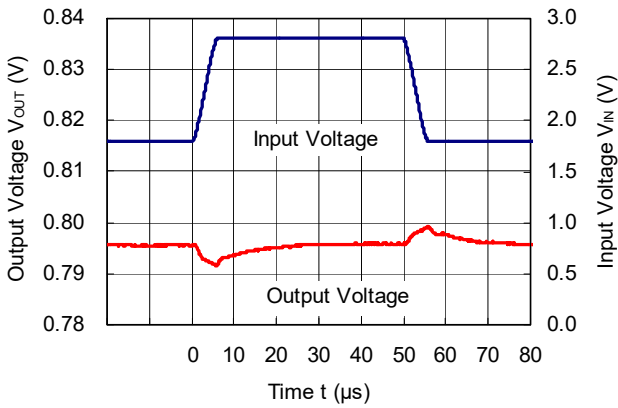

RP108J421x

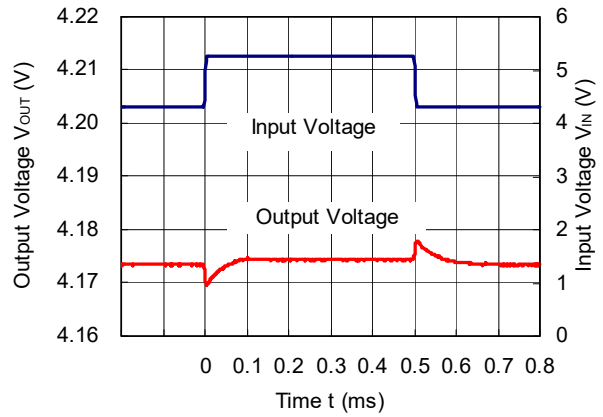

11) Load Transient Response (C1 = C2 = 10  $\mu$ F, tr = tf = 0.5  $\mu$ s, Ta = 25°C)

RP108J081x

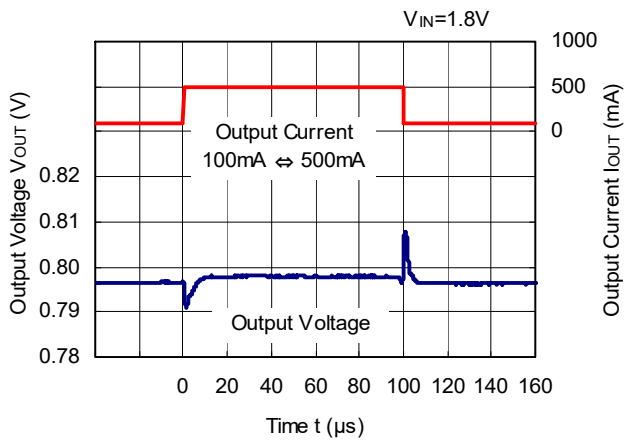

RP108J081x

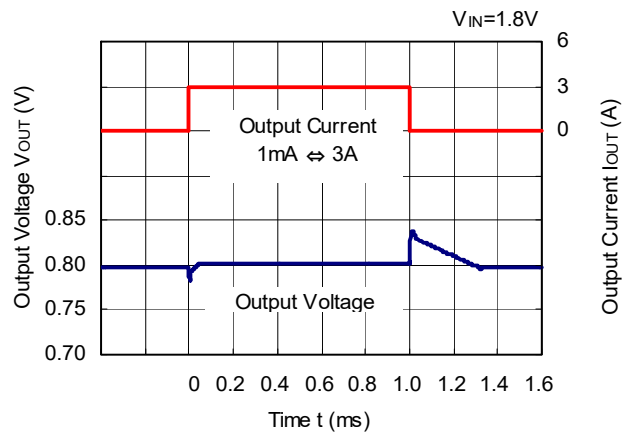

RP108J421x

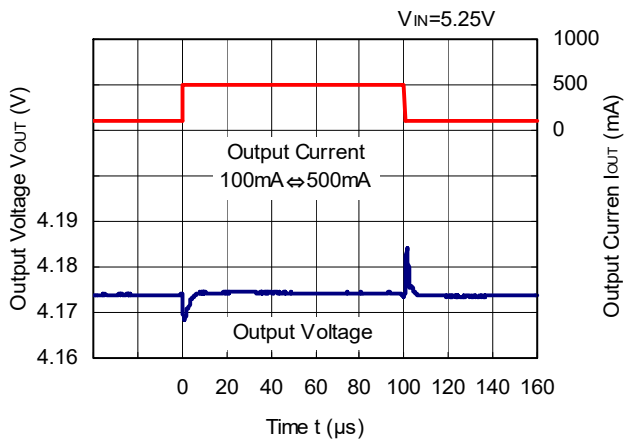

RP108J421x

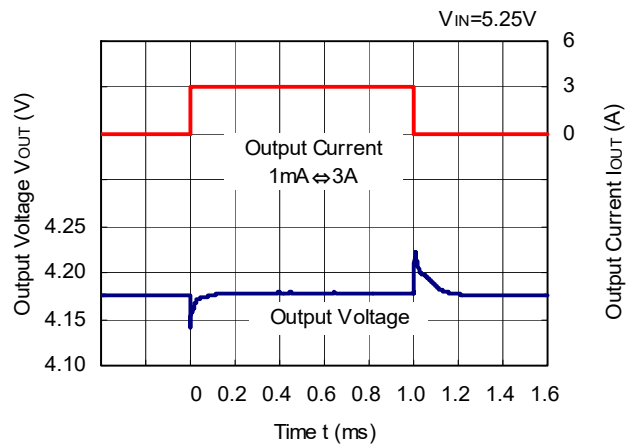



12) Turn on Speed with CE pin (C1 = Ceramic 10  $\mu$ F, C2 = Ceramic 10  $\mu$ F, Ta = 25°C)

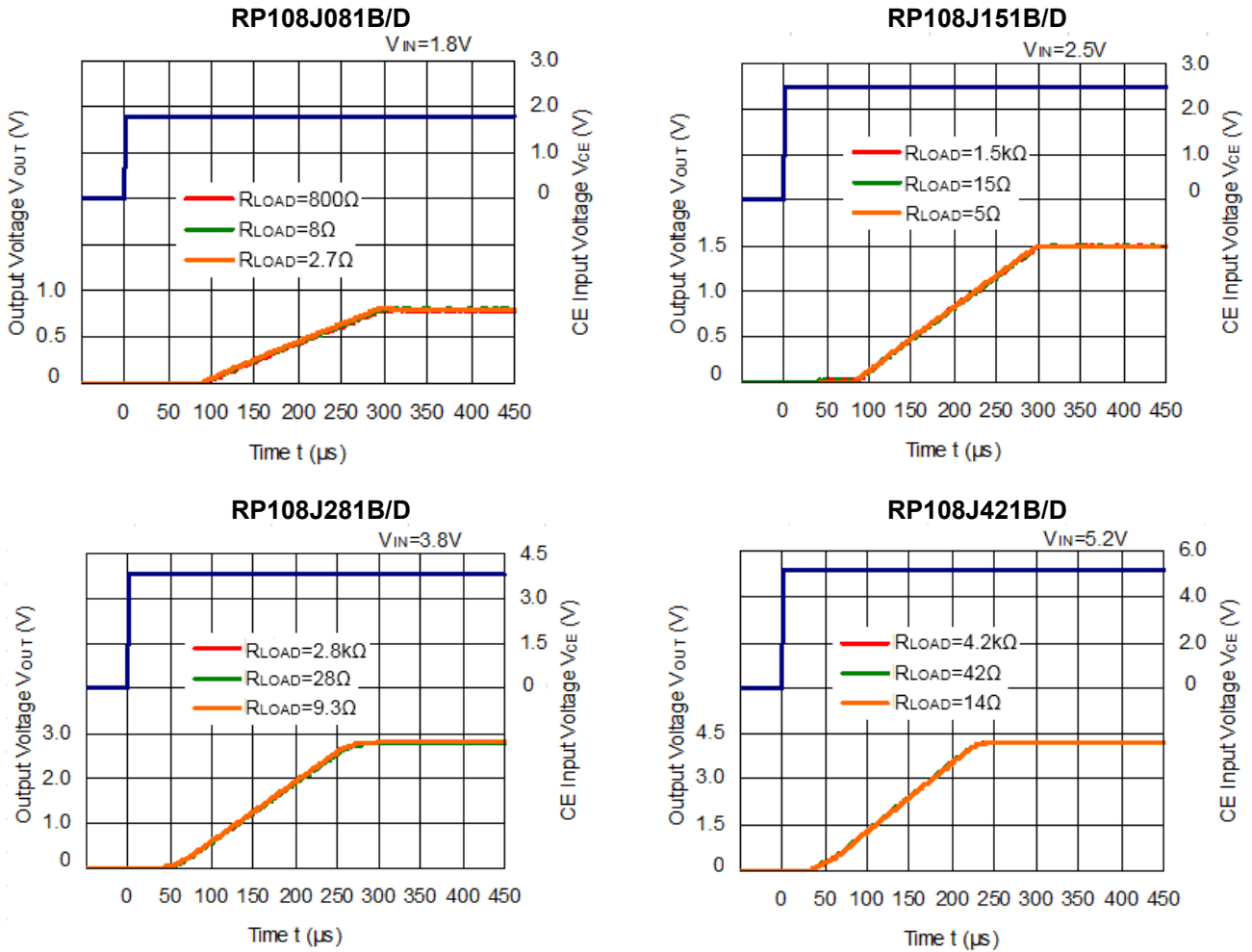

13) Turn off Speed with CE pin (C1 = Ceramic 10  $\mu$ F, C2 = Ceramic 10  $\mu$ F, Ta = 25°C)

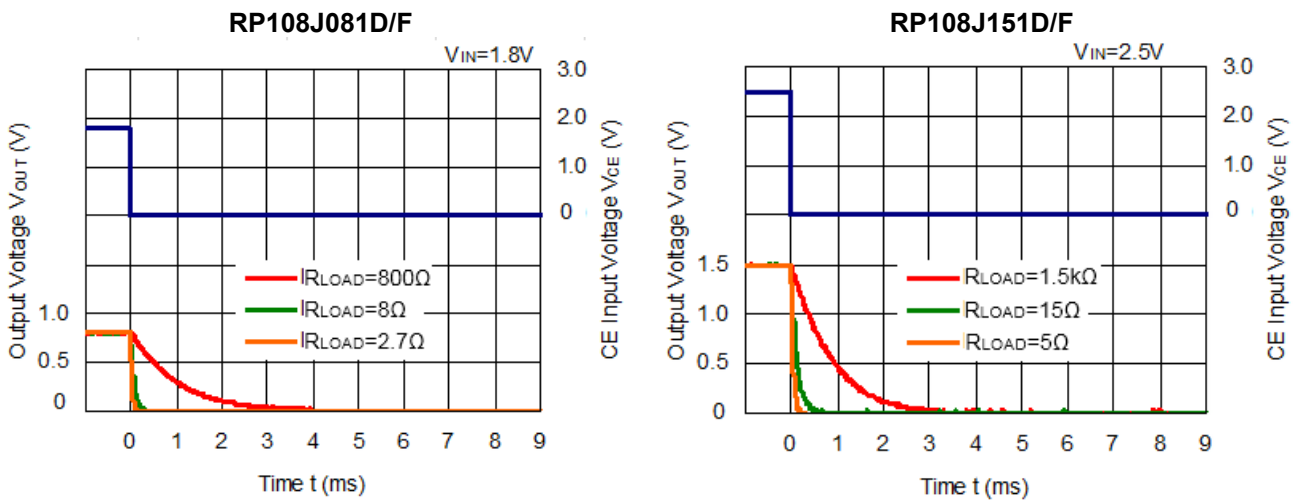

RP108J281D/F

$V_{IN}=3.8V$

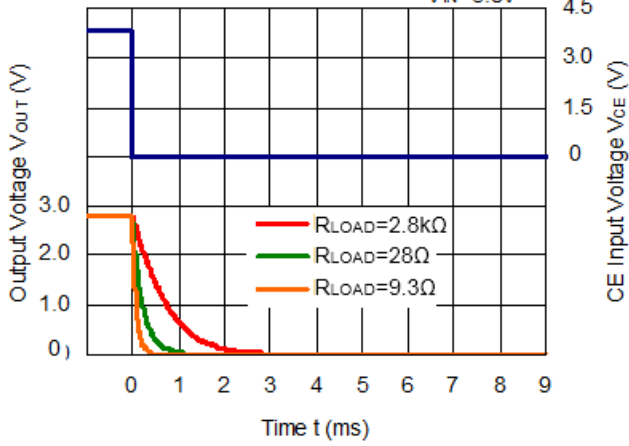

RP108J421D/F

$V_{IN}=5.2V$

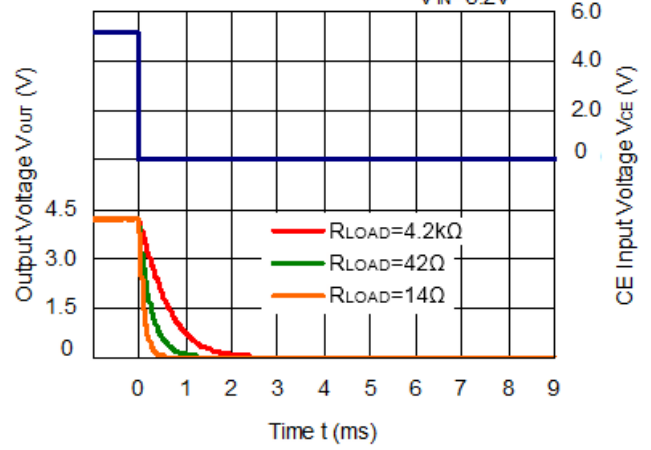

14) Inrush Current

RP108J081B/D

$R_{LOAD}=8\Omega, V_{IN}=1.8V$

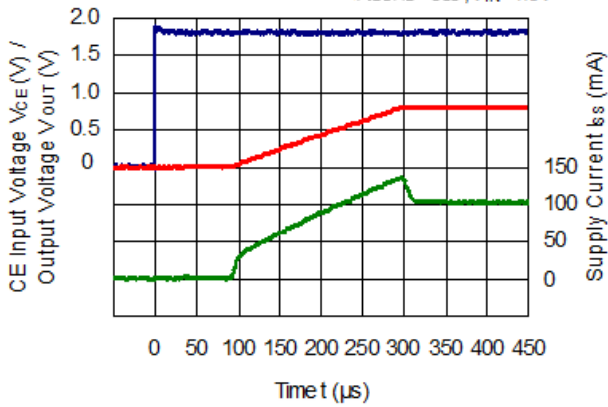

RP108J421B/D

$R_{LOAD}=42\Omega, V_{IN}=5.2V$

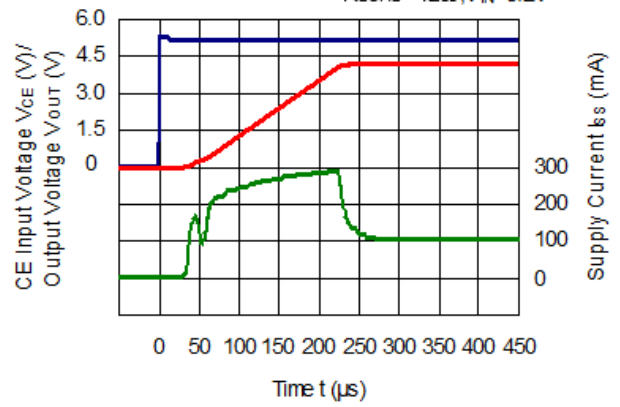

## ESR vs. OUTPUT CURRENT

When using this device, consider the following points: The relations between  $I_{OUT}$  (Output Current) and ESR of an output capacitor are shown below. The conditions when the white noise level is under  $40 \mu\text{V}$  (Avg.) are marked as the hatched area in the graph.

### Measurement Conditions

- Frequency Band: 10 Hz to 2 MHz
- Temperature :  $-40^{\circ}\text{C}$  to  $85^{\circ}\text{C}$
- Hatched area : Noise level is under  $40 \mu\text{V}$
- C1, C2 :  $10 \mu\text{F}$  or more

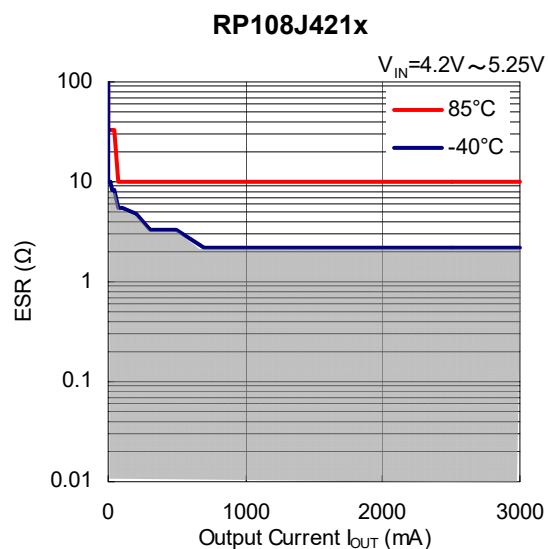
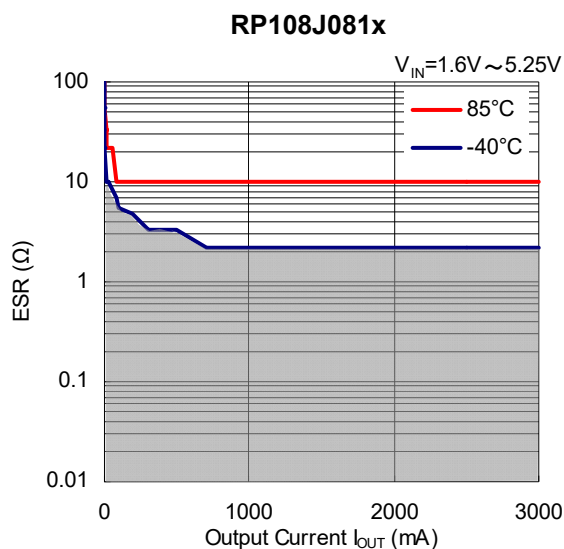



1. The products and the product specifications described in this document are subject to change or discontinuation of production without notice for reasons such as improvement. Therefore, before deciding to use the products, please refer to our sales representatives for the latest information thereon.
2. The materials in this document may not be copied or otherwise reproduced in whole or in part without prior written consent of our company.
3. Please be sure to take any necessary formalities under relevant laws or regulations before exporting or otherwise taking out of your country the products or the technical information described herein.
4. The technical information described in this document shows typical characteristics of and example application circuits for the products. The release of such information is not to be construed as a warranty of or a grant of license under our company's or any third party's intellectual property rights or any other rights.
5. The products listed in this document are intended and designed for use as general electronic components in standard applications (office equipment, telecommunication equipment, measuring instruments, consumer electronic products, amusement equipment etc.). Those customers intending to use a product in an application requiring extreme quality and reliability, for example, in a highly specific application where the failure or misoperation of the product could result in human injury or death (aircraft, spacevehicle, nuclear reactor control system, traffic control system, automotive and transportation equipment, combustion equipment, safety devices, life support system etc.) should first contact us.
6. We are making our continuous effort to improve the quality and reliability of our products, but semiconductor products are likely to fail with certain probability. In order to prevent any injury to persons or damages to property resulting from such failure, customers should be careful enough to incorporate safety measures in their design, such as redundancy feature, fire containment feature and fail-safe feature. We do not assume any liability or responsibility for any loss or damage arising from misuse or inappropriate use of the products.
7. Anti-radiation design is not implemented in the products described in this document.
8. The X-ray exposure can influence functions and characteristics of the products. Confirm the product functions and characteristics in the evaluation stage.
9. WLCSP products should be used in light shielded environments. The light exposure can influence functions and characteristics of the products under operation or storage.
10. There can be variation in the marking when different AOI (Automated Optical Inspection) equipment is used. In the case of recognizing the marking characteristic with AOI, please contact our sales or our distributor before attempting to use AOI.
11. Please contact our sales representatives should you have any questions or comments concerning the products or the technical information.



**Nisshinbo Micro Devices Inc.**

**Official website**

<https://www.nisshinbo-microdevices.co.jp/en/>

**Purchase information**

<https://www.nisshinbo-microdevices.co.jp/en/buy/>

