

500 mA 36V Input Low Supply Current LDO for Industrial Application

NO. EY-304-230124

ROUTLINE

R1517x is a CMOS-based LDO featuring 500 mA output current and 36 V input voltage. In addition to a conventional regulator circuit, R1517x consists of a constant slope circuit as a soft-start function, a fold-back protection circuit, a short current limit circuit, and a thermal shutdown circuit.

R1517x supports the internal fixed output voltage type of R1517xxx1B/D/E/F, and the output voltage of R1517x001C can adjust the output voltage be set with an external resistor, and the setting range is from 2.5V to Max 20V. As for the soft-start time, R1517x is fixed internal in R1517xxx1B/D/E/F and is set to 120 μ s (Typ). And the soft-start time in R1517xxx1E/F is adjustable by external capacitors. R1517x supports the auto-discharge function at standby in R1517xxx1D/F.

R1517x is available in two packages for ultra-high wattage: HSOP-6J and TO-252-5-P2.

This is a high-reliability semiconductor device for industrial application (-Y) that has passed both the screening at high temperature and the reliability test with extended hours.

FEATURES

- Input Voltage Range (Maximum Rating) 3.5 V to 36.0 V (50.0V)
- Operating Temperature Range -40°C to 125°C
- Supply Current Typ. 18 μA
- Standby Current Typ. 0.1 μA
- Dropout Voltage Typ. 0.35 V ($I_{\text{OUT}} = 500 \text{ mA}$, $V_{\text{OUT}} = 5.0 \text{ V}$)
- Output Voltage Accuracy $\pm 0.8\%$ ($V_{\text{OUT}} \leq 5.0 \text{ V}$)
- Temperature-Drift Coefficient of Output Voltage Typ. $\pm 60 \text{ ppm}/^{\circ}\text{C}$ ($-40^{\circ}\text{C} \leq T_a \leq 125^{\circ}\text{C}$)
- Line Regulation Typ. 0.01%/V
- Packages HSOP-6J, TO-252-5-P2
- Output Voltage Range 2.5 V/3.3 V/3.4 V/5.0 V/8.5 V
 R1517x001C: Adjustable from 2.5 V to 20.0 V with External Resistors.
 Feedback Voltage: 2.5 V
- Built-in Short Current Limit Circuit Typ. 75 mA
- Built-in Fold-Back Protection Circuit Min. 500 mA
- Built-in Thermal Shutdown Circuit Typ. 160°C
- Built-in Soft-start Circuit Typ. 120 μs
 R1517xxx1E/F: Adjustable Time Setting with External Capacitors.
- Usable Ceramic Capacitors 0.1 μF or more
 R1517x001C: 1.0 μF or more

APPLICATIONS

- Industrial equipment such as FAs and smart meters.
- Equipment used under high-temperature conditions such as surveillance camera and vending machine.
- Equipment accompanied by self-heating such as motor and lighting.

BLOCK DIAGRAMS

R1517xxx1B

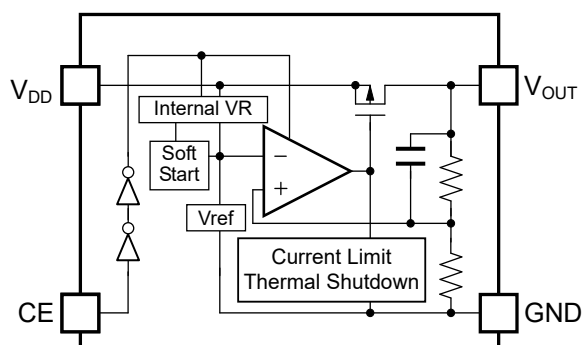

R1517x001C

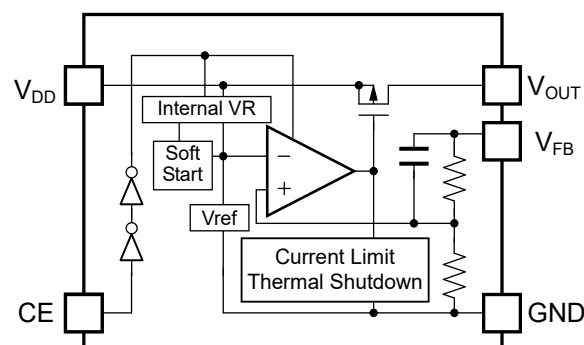

R1517xxx1D

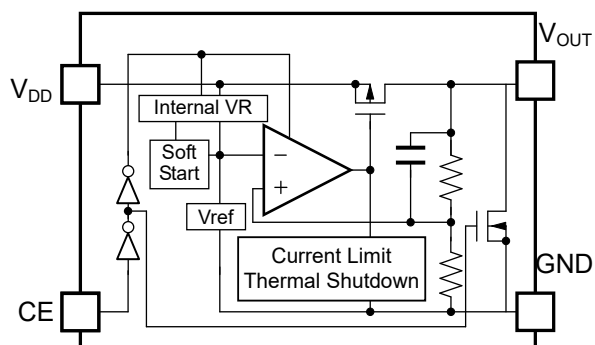

R1517xxx1E

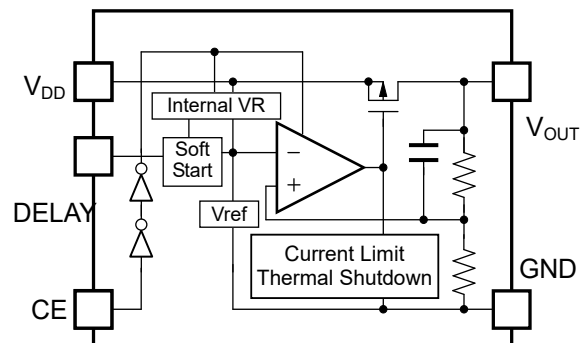

R1517xxx1F

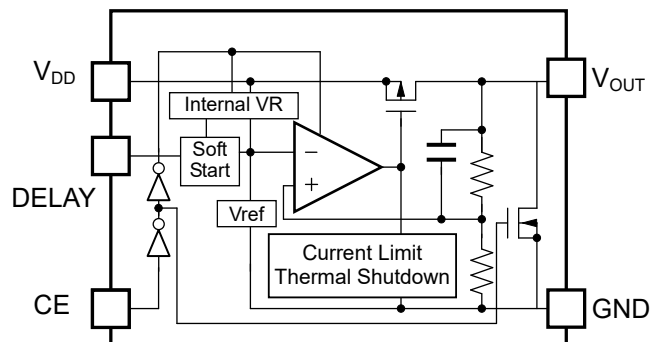

SELECTION GUIDE

The output voltage, version, and package type for this device can be selected at the user's request.

Product Name	Package	Quantity per Reel	Pb Free	Halogen Free
R1517Sxx1*-E2-YE	HSOP-6J	1,000 pcs	Yes	Yes
R1517S001C-E2-YE				
R1517Jxx1*-T1-YE	TO-252-5-P2	3,000 pcs	Yes	Yes
R1517J001C-T1-YE				

xx: Specify the set output voltage (V_{SET})
 2.5 V (25) / 3.3 V (33) / 3.4 V (34) / 5.0 V (50) / 8.5 V (85)

Adjustable output voltage setting type is fixed to (00)

Note: For R1517S001C-E2-YE and R1517J001C-T1-YE (No auto-discharge function)

- * : Specify the version with desired functions
 B: No auto-discharge function
 D: Auto-discharge function
 E: No auto-discharge function / Adjustable soft-start time setting
 F: Auto-discharge function / Adjustable soft-start time setting

Auto-discharge function quickly lowers the output voltage to 0 V by releasing the electrical charge in the external capacitor when the chip enable signal is switched from the active mode to the standby mode.

PIN DESCRIPTION

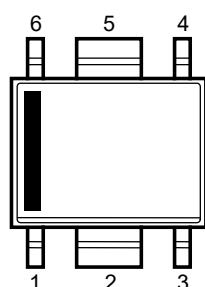

HSOP-6J

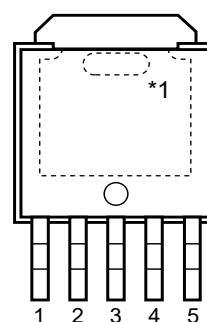

TO-252-5-P2

HSOP-6J

Pin No.	Symbol	Description	
1	V _{DD}	Input Pin	
2	GND	Ground Pin	
3	NC	No Connection	R1517Sxx1B/D
	V _{FB}	Feedback Pin	R1517S001C
	DELAY	Soft-start Time Pin	R1517Sxx1E/F
4	CE	Chip Enable Pin, Active-high	
5	GND	Ground Pin	
6	V _{OUT}	Output Pin	

TO-252-5-P2

Pin No.	Symbol	Description	
1	V _{DD}	Input Pin	
2	NC	No Connection	R1517Jxx1B/D
	V _{FB}	Feedback Pin	R1517J001C
	DELAY	Adjustable Soft-start Time Pin	R1517Jxx1E/F
3	GND	Ground Pin	
4	CE	Chip Enable Pin, Active-high	
5	V _{OUT}	Output Pin	

*1 The tab on the bottom of the package enhances thermal performance and is electrically connected to GND (substrate level). It is recommended that the tab be connected to the ground plane on the board, or otherwise be left open.

PIN EQUIVALENT CIRCUIT DIAGRAMS

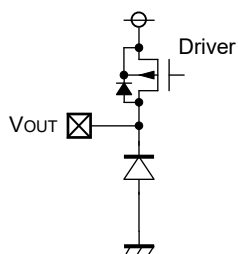

V_{OUT} Pin

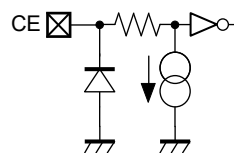

CE Pin

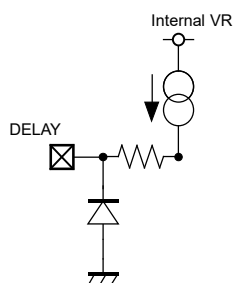

DELAY Pin (R1517xxx1E/F)

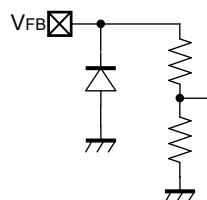

V_{FB} Pin (R1517x001C)

ABSOLUTE MAXIMUM RATINGS

Symbol	Item	Rating	Unit
V _{IN}	Input Voltage	-0.3 to 50	V
V _{IN}	Peak Input Voltage* ¹	60	V
V _{CE}	Input Voltage (CE Pin)	-0.3 to 50	V
V _{FB}	Input Voltage (V _{FB} Pin)	-0.3 to 50	V
V _{OUT}	Output Voltage	-0.3 to V _{IN} + 0.3 ≤ 50	V
P _D	Power Dissipation	Refer to Appendix "Power Dissipation"	
T _j	Junction Temperature	-40 to 150	°C
T _{stg}	Storage Temperature Range	-55 to 150	°C

*¹ Duration time = 200 ms

ABSOLUTE MAXIMUM RATINGS

Electronic and mechanical stress momentarily exceeded absolute maximum ratings may cause permanent damage and may degrade the life time and safety for both device and system using the device in the field. The functional operation at or over these absolute maximum ratings is not assured.

RECOMMENDED OPERATING CONDITIONS

Symbol	Item	Rating	Unit
V _{IN}	Input Voltage	3.5 to 36	V
T _a	Operating Temperature Range	-40 to 125	°C

RECOMMENDED OPERATING CONDITONS

All of electronic equipment should be designed that the mounted semiconductor devices operate within the recommended operating conditions. The semiconductor devices cannot operate normally over the recommended operating conditions, even if they are used over such conditions by momentary electronic noise or surge. And the semiconductor devices may receive serious damage when they continue to operate over the recommended operating conditions.

ELECTRICAL CHARACTERISTICS

$V_{IN} = V_{SET} + 1.0 \text{ V}$, $I_{OUT} = 1 \text{ mA}$, $C_{IN} = C_{OUT} = 0.1 \mu\text{F}$, unless otherwise noted.

The specifications surrounded by are guaranteed by design engineering at $-40^\circ\text{C} \leq T_a \leq 125^\circ\text{C}$.

R1517xxx1B/D

($T_a = 25^\circ\text{C}$)

Symbol	Item	Conditions	Min.	Typ.	Max.	Unit	
V_{OUT}	Output Voltage	$T_a = 25^\circ\text{C}$	$V_{SET} \leq 5.0 \text{ V}$	$\times 0.992$		$\times 1.008$	V
			$V_{SET} > 5.0 \text{ V}$	$\times 0.99$		$\times 1.01$	V
		$-40^\circ\text{C} \leq T_a \leq 125^\circ\text{C}$	$V_{SET} \leq 5.0 \text{ V}$	×0.982		×1.018	V
			$V_{SET} > 5.0 \text{ V}$	×0.98		×1.02	V
$\frac{\Delta V_{OUT}}{\Delta I_{OUT}}$	Load Regulation	$V_{IN} = V_{SET} + 2.0 \text{ V}$ $1 \text{ mA} \leq I_{OUT} \leq 250 \text{ mA}$	-15	3	25	mV	
		$V_{IN} = V_{SET} + 2.0 \text{ V}$ $1 \text{ mA} \leq I_{OUT} \leq 500 \text{ mA}$	-25	5	40	mV	
V_{DIF}	Dropout Voltage	$I_{OUT} = 500 \text{ mA}$	Refer to Product-specific Electrical Characteristics.				
I_{SS}	Supply Current	$I_{OUT} = 0 \text{ mA}$		18	36	μA	
Istandby	Standby Current	$V_{CE} = 0 \text{ V}$		0.1	2.0	μA	
$\frac{\Delta V_{OUT}}{\Delta V_{IN}}$	Line Regulation	$V_{SET} + 0.5 \text{ V} \leq V_{IN} \leq 36 \text{ V}$, Under the condition of $V_{IN} \geq 3.5 \text{ V}$		0.01	0.02	%/V	
I_{LIM}	Output Current Limit	$V_{IN} = V_{SET} + 2.0 \text{ V}$	500	750		mA	
I_{SC}	Short Current Limit	$V_{IN} = 5.0 \text{ V}$, $V_{OUT} = 0 \text{ V}$		75		mA	
I_{PD}	CE Pull-down Current	$V_{CE} = 5.0 \text{ V}$		0.2	0.6	μA	
		$V_{CE} = 36 \text{ V}$		0.5	1.3	μA	
t_{D1}	Soft-start Time 1			120		μs	
V_{CEH}	CE Input Voltage "H"		2.2		36	V	
V_{CEL}	CE Input Voltage "L"		0		1.0	V	
T_{TSD}	Thermal Shutdown Temperature	Junction Temperature	150	160		$^\circ\text{C}$	
T_{TSR}	Thermal Shutdown Released Temperature	Junction Temperature	125	135		$^\circ\text{C}$	
R_{LOW}	Low Output Nch Tr. ON Resistance (R1517xxx1D)	$V_{IN} = 14.0 \text{ V}$, $V_{CE} = 0 \text{ V}$	1.0	3.2	5.0	k Ω	

All test items listed under Electrical Characteristics are done under the pulse load condition ($T_j \approx T_a = 25^\circ\text{C}$) except for Soft-start Time 1.

$V_{IN} = V_{FB} (= 2.5 \text{ V}) + 1.0 \text{ V} = 3.5 \text{ V}$, $I_{OUT} = 1 \text{ mA}$, $C_{IN} = 0.1 \mu\text{F}$, $C_{OUT} = 1.0 \mu\text{F}$, unless otherwise noted.

The specifications surrounded by are guaranteed by design engineering at $-40^\circ\text{C} \leq T_a \leq 125^\circ\text{C}$.

R1517x001C

(Ta = 25°C)

Symbol	Item	Conditions	Min.	Typ.	Max.	Unit
V_{FB}	Feedback Voltage	$T_a = 25^\circ\text{C}$	2.480		2.520	V
		$-40^\circ\text{C} \leq T_a \leq 125^\circ\text{C}$	2.455		2.545	V
$\Delta V_{OUT} / \Delta I_{OUT}$	Load Regulation	$V_{IN} = 4.5 \text{ V}$ $1 \text{ mA} \leq I_{OUT} \leq 250 \text{ mA}$	-10	3	10	mV
		$V_{IN} = 4.5 \text{ V}$ $1 \text{ mA} \leq I_{OUT} \leq 500 \text{ mA}$	-20	5	20	mV
V_{DIF}	Dropout Voltage	$I_{OUT} = 500 \text{ mA}$		/	1.0	V
I_{SS}	Supply Current	$I_{OUT} = 0 \text{ mA}$		18	36	μA
Istandby	Standby Current	$V_{CE} = 0 \text{ V}$		0.1	2.0	μA
$\Delta V_{OUT} / \Delta V_{IN}$	Line Regulation	$3.5 \text{ V} \leq V_{IN} \leq 36 \text{ V}$		0.01	0.02	%/V
I_{LIM}	Output Current Limit	$V_{IN} = 4.5 \text{ V}$	500	750		mA
I_{SC}	Short Current Limit	$V_{IN} = 5.0 \text{ V}$, $V_{OUT} = V_{FB} = 0 \text{ V}$		75		mA
I_{PD}	CE Pull-down Current	$V_{CE} = 5.0 \text{ V}$		0.2	0.6	μA
		$V_{CE} = 36 \text{ V}$		0.5	1.3	μA
t_{D1}	Soft-start Time 1			120		μs
V_{CEH}	CE Input Voltage "H"		2.2		36	V
V_{CEL}	CE Input Voltage "L"		0		1.0	V
T_{TSD}	Thermal Shutdown Temperature	Junction Temperature	150	160		$^\circ\text{C}$
T_{TSR}	Thermal Shutdown Released Temperature	Junction Temperature	125	135		$^\circ\text{C}$

$V_{OUT} = V_{FB} = 2.5 \text{ V}$ (excluding short circuit current)

All test items listed under Electrical Characteristics are done under the pulse load condition ($T_j \approx T_a = 25^\circ\text{C}$) except for Soft-start Time 1.

$V_{IN} = V_{SET} + 1.0 \text{ V}$, $I_{OUT} = 1 \text{ mA}$, $C_{IN} = C_{OUT} = 0.1 \mu\text{F}$, unless otherwise noted.

The specifications surrounded by are guaranteed by design engineering at $-40^\circ\text{C} \leq T_a \leq 125^\circ\text{C}$.

R1517xxx1E/F

(Ta = 25°C)

Symbol	Item	Conditions	Min.	Typ.	Max.	Unit	
V_{OUT}	Output Voltage	Ta = 25°C	$V_{SET} \leq 5.0 \text{ V}$	$\times 0.992$		$\times 1.008$	V
			$V_{SET} > 5.0 \text{ V}$	$\times 0.99$		$\times 1.01$	V
		$-40^\circ\text{C} \leq T_a \leq 125^\circ\text{C}$	$V_{SET} \leq 5.0 \text{ V}$	×0.982		×1.018	V
			$V_{SET} > 5.0 \text{ V}$	×0.98		×1.02	V
$\Delta V_{OUT} / \Delta I_{OUT}$	Load Regulation	$V_{IN} = V_{SET} + 2.0 \text{ V}$ $1 \text{ mA} \leq I_{OUT} \leq 250 \text{ mA}$	-15	3	25	mV	
		$V_{IN} = V_{SET} + 2.0 \text{ V}$ $1 \text{ mA} \leq I_{OUT} \leq 500 \text{ mA}$	-25	5	40	mV	
V_{DIF}	Dropout Voltage	$I_{OUT} = 500 \text{ mA}$	Refer to Product-specific Electrical Characteristics.				
I_{SS}	Supply Current	$I_{OUT} = 0 \text{ mA}$		18	36	μA	
Istandby	Standby Current	$V_{CE} = 0 \text{ V}$		0.1	2.0	μA	
$\Delta V_{OUT} / \Delta V_{IN}$	Line Regulation	$V_{SET} + 0.5 \text{ V} \leq V_{IN} \leq 36 \text{ V}$, Under the condition of $V_{IN} \geq 3.5 \text{ V}$		0.01	0.02	%/V	
I_{LIM}	Output Current Limit	$V_{IN} = V_{SET} + 2.0 \text{ V}$	500	750		mA	
I_{SC}	Short Current Limit	$V_{IN} = 5.0 \text{ V}$, $V_{OUT} = 0 \text{ V}$		75		mA	
I_{PD}	CE Pull-down Current	$V_{CE} = 5.0 \text{ V}$		0.2	0.6	μA	
		$V_{CE} = 36 \text{ V}$		0.5	1.3	μA	
I_{DELAY}	DELAY Current	DELAY = GND	1.5	2.5	3.5	μA	
t_{D1}	Soft-start Time 1	DELAY = OPEN		26		μs	
t_{D2}	Soft-start Time 2	DELAY = 0.001 μF	210	290	415	μs	
V_{CEH}	CE Input Voltage "H"		2.2		36	V	
V_{CEL}	CE Input Voltage "L"		0		1.0	V	
T_{TSD}	Thermal Shutdown Temperature	Junction Temperature	150	160		$^\circ\text{C}$	
T_{TSR}	Thermal Shutdown Released Temperature	Junction Temperature	125	135		$^\circ\text{C}$	
R_{LOW}	Low Output Nch Tr. ON Resistance (R1517xxx1F)	$V_{IN} = 14.0 \text{ V}$, $V_{CE} = 0 \text{ V}$	1.0	3.2	5.0	k Ω	

All test items listed under Electrical Characteristics are done under the pulse load condition ($T_j \approx T_a = 25^\circ\text{C}$) except for Soft-start Time 1 and Soft-start Time 2.

Product-specific Electrical Characteristics

The specifications surrounded by are guaranteed by design engineering at $-40^{\circ}\text{C} \leq T_a \leq 125^{\circ}\text{C}$.

R1517xxx1B/D/E/F

($T_a = 25^{\circ}\text{C}$)

Product Name	V_{OUT} [V] ($T_a = 25^{\circ}\text{C}$)			V_{OUT} [V] ($-40 \leq T_a \leq 125^{\circ}\text{C}$)			V_{DIF} [V]	
	Min.	Typ.	Max.	Min.	Typ.	Max.	Typ.	Max.
R1517x251x	2.480	2.500	2.520	2.455	2.500	2.545	0.45	1.00
R1517x331x	3.274	3.300	3.326	3.241	3.300	3.359		0.77
R1517x341x	3.373	3.400	3.427	3.339	3.400	3.461	0.35	0.62
R1517x501x	4.960	5.000	5.040	4.910	5.000	5.090		
R1517x851x	8.415	8.500	8.585	8.330	8.500	8.670	0.30	0.50

TYPICAL APPLICATION

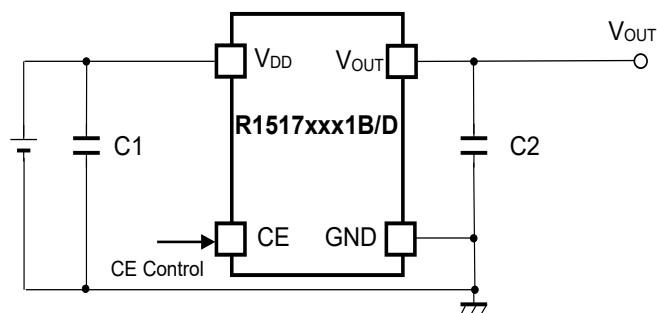

R1517xxx1B/D Typical Application

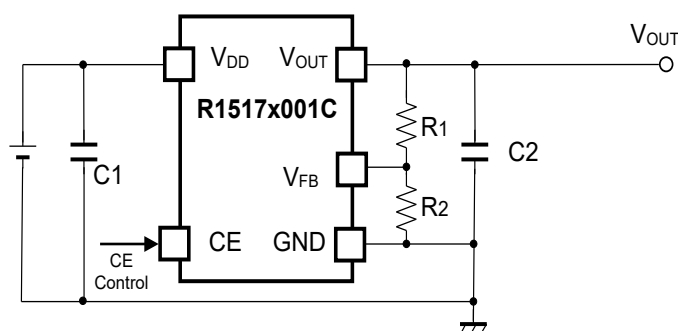

R1517x001C Typical Application

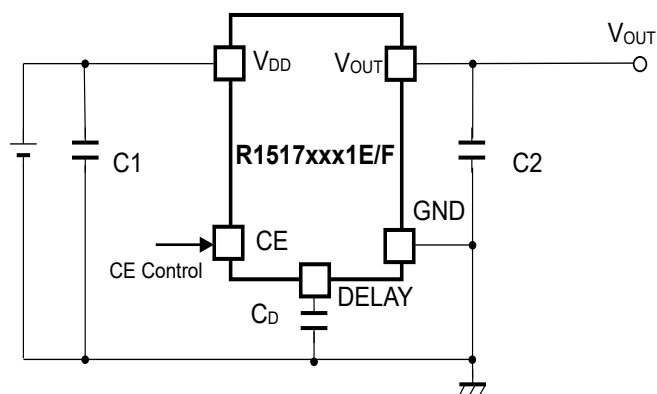

R1517xxx1E/F Typical Application

External Components:

Symbol	Description
R1517xxx1B/D/E/F	
C1 (C _{IN})	0.1μF (Ceramic)
C2 (C _{OUT})	0.1μF (Ceramic)
R1517x001C	
C1 (C _{IN})	0.1μF (Ceramic)
C2 (C _{OUT})	1.0μF (Ceramic)

TECHNICAL NOTES

Phase Compensation

In LDO regulators, phase compensation is provided to secure stable operation even when the load current is varied. For this purpose, use the capacitor C2 of 0.1 μF or more (R1517xxx1B/D/E/F) / 1.0 μF or more (R1517x001C).

When using a tantalum type capacitor and the ESR (Equivalent Series Resistance) value is large, the output might be unstable. Evaluate the circuit including consideration of frequency characteristics.

For the externally adjustable output voltage type (R1517x001C), use 10 k Ω or lower resistance R2.

PCB Layout

Ensure the V_{DD} and GND lines are sufficiently robust. If their impedance is too high, noise pickup or unstable operation may result. Connect 0.1 μF or more of the capacitor C1 between the V_{DD} and GND, and as close as possible to the pins.

In addition, connect the capacitor C2 between V_{OUT} and GND, and as close as possible to the pins.

OPERATION DESCRIPTION

Thermal Shutdown Function

Thermal shutdown function is included in this device. If the junction temperature is more than or equal to 160°C (Typ.), the operation of the regulator would stop. After that, when the junction temperature is less than or equal to 135°C (Typ.), the operation of the regulator would restart. Unless the cause of rising temperature is removed, the regulator repeats on and off, and output waveform would be like consecutive pulses.

Adjustable Output Voltage Setting (R1517x001C)

The output voltage of R1517x001C can be adjusted by using the external divider resistors (R1, R2). By using the following equation, the output voltage (V_{OUT}) can be determined. The voltage which is fixed inside the IC is described as V_{FB} .

$$V_{OUT} = V_{FB} \times ((R1 + R2) / R2)$$

Recommended Range: $2.5 \text{ V} \leq V_{OUT} \leq 20.0 \text{ V}$

$V_{FB} = 2.5 \text{ V}$

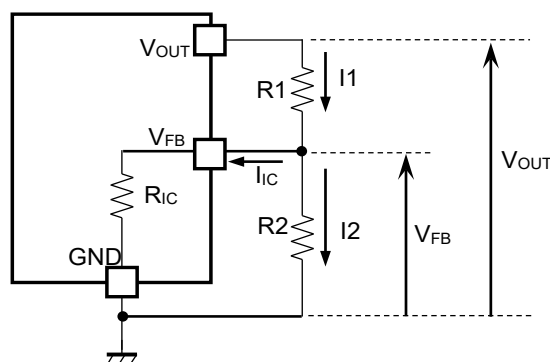

Output Voltage Adjustment Using External Divider Resistors (R1, R2)

R_{IC} of the R1517x001C is approximately Typ. 1.35 M Ω ($T_a=25^\circ\text{C}$, guaranteed by design engineering). For better accuracy, setting $R1 \ll R_{IC}$ reduces errors. The resistance value for R2 should be set to 10 k Ω or lower. It is easily affected by noises when setting the value of R1 and R2 larger, which makes the impedance of V_{FB} pin larger.

R_{IC} could be affected by the temperature, therefore evaluate the circuit taking the actual conditions of use into account when deciding the resistance values for R1 and R2.

Soft-start Function

R1517x is equipped with a constant slope circuit, which achieves a soft-start function. This circuit allows the output voltage to start up gradually when the CE is turned on. The constant slope circuit minimizes the inrush current at the start-up and also prevents the overshoot of the output voltage. For R1517xxx1B/C/D, the capacitor to create the start-up slope is built in this device that does not require any external components. The start-up time and the start-up slope angle are fixed inside the device. In R1517xxx1E/F, the soft-start time is adjustable by inserting the external capacitor to DELAY pin. By using the following equation, the relation between the soft-start time t_D [s] and DELAY pin capacitor C_D [F] is determined.

$$t_D = ((C_D + 90 \times 10^{-12}) / I_{\text{DELAY}}) \times 0.73$$

When the capacitor C_D is not used in R1517xxx1E/F, use the DELAY pin as OPEN. At that time, $C_D = 0$ in the above equation, therefore the start-up time is about 26 μs . However, be sure to consider approximately 50 μs of CE delay time.

The capacity (C_D) of the DELAY pin is discharged when V_{IN} is input and $\text{CE} = \text{L}$. If the C_D is restarted without being discharged, the soft start time may be shorter than the set time.

Conventional Inrush Current Limit Circuit

(Diagrammatic sketch)

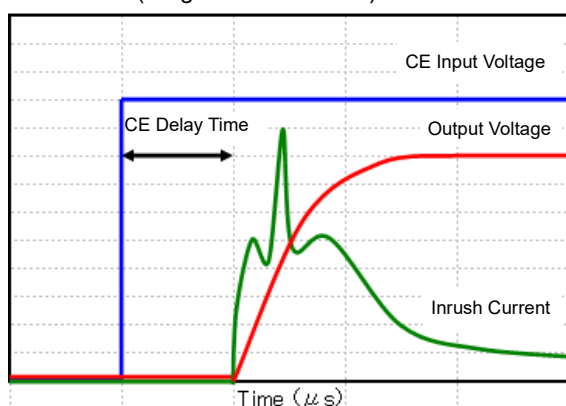

Constant Slope Circuit

(Diagrammatic sketch)

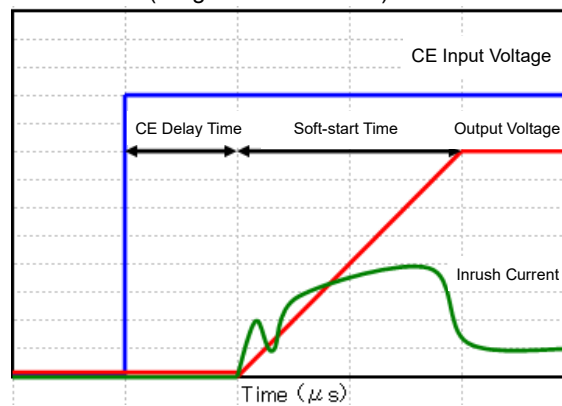

TYPICAL CHARACTERISTICS

Note: Typical Characteristics are intended to be used as reference data; they are not guaranteed.

1) Output Voltage vs. Output Current (Ta = 25°C)

R1517x25xx, R1517x001C

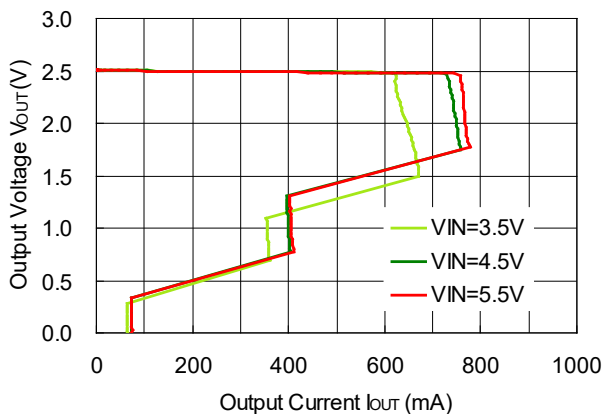

R1517x33xx

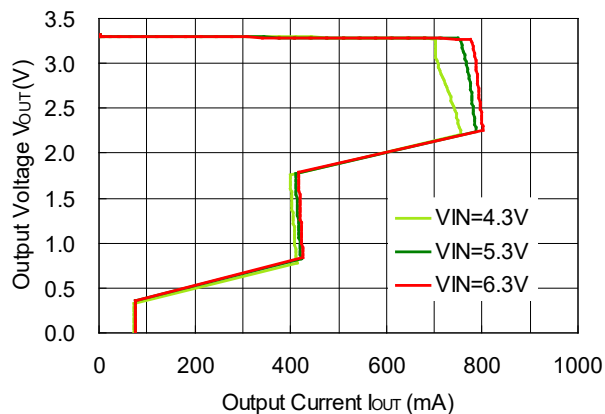

R1517x50xx

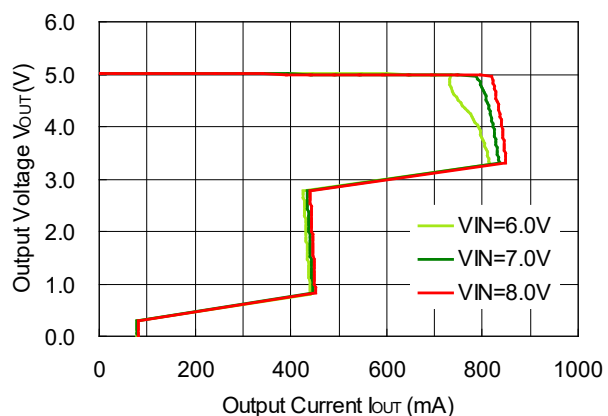

R1517x85xx

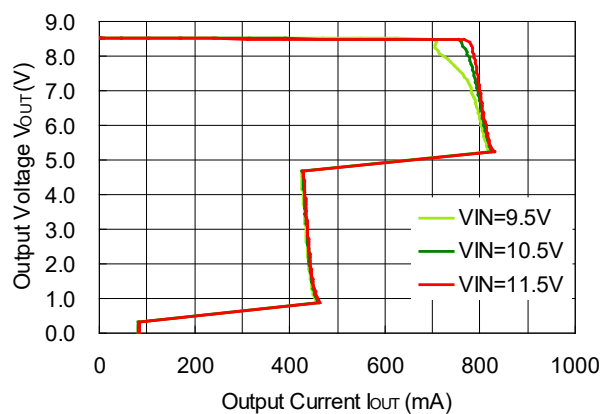

2) Output Voltage vs. Input Voltage (Ta = 25°C)

R1517x25xx

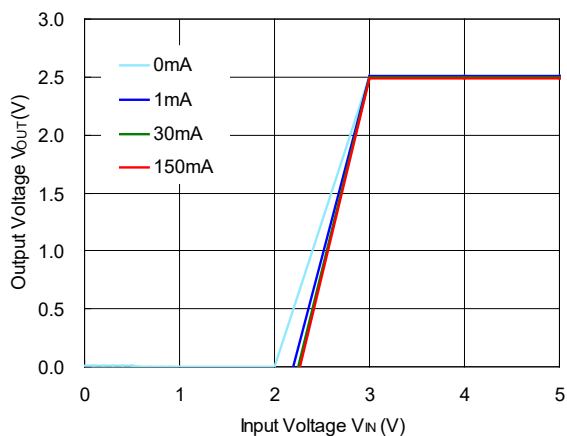

R1517x33xx

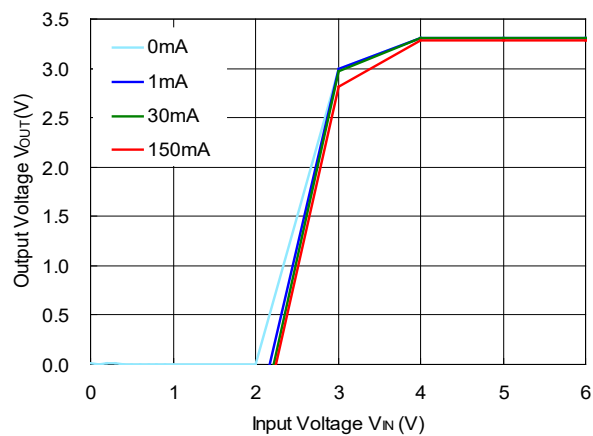

R1517x50xx

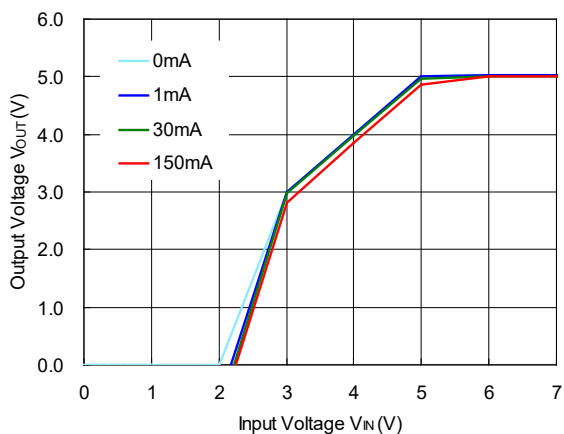

R1517x85xx

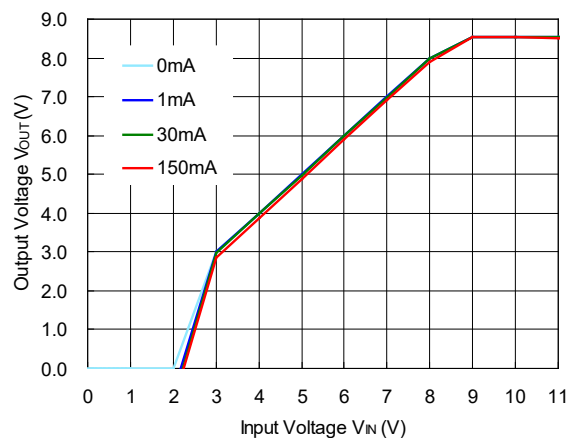

3) Supply Current vs. Input Voltage ($I_{OUT} = 0 \text{ mA}$)

R1517x25xx, R1517x001C

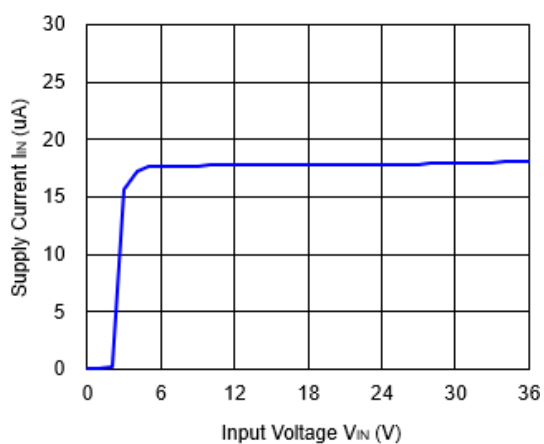

R1517x33xx

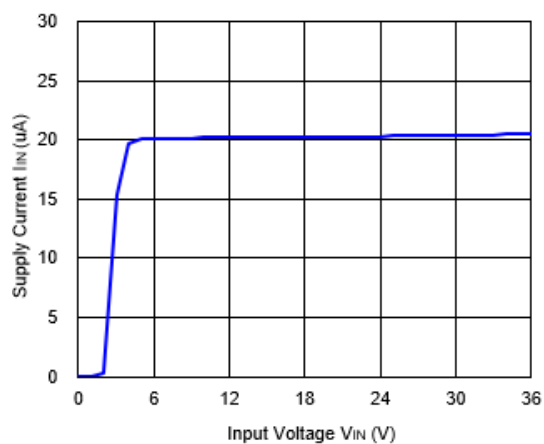

R1517x50xx

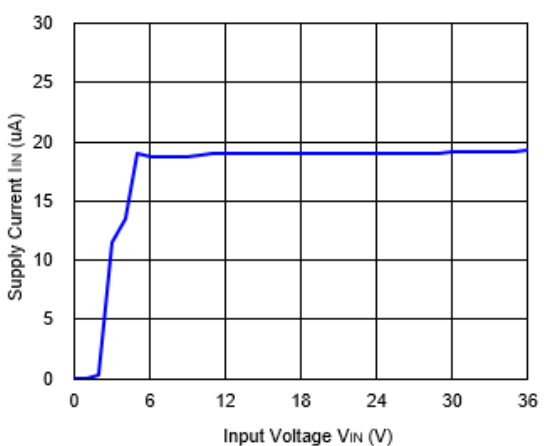

R1517x85xx

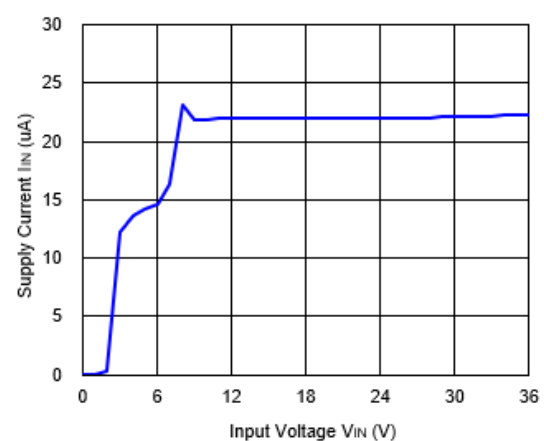

4) Output Voltage vs. Operating Temperature

R1517x25xx, R1517x001C

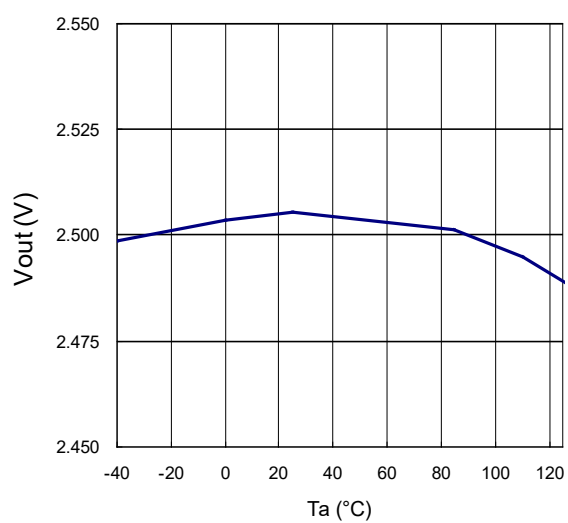

R1517x33xx

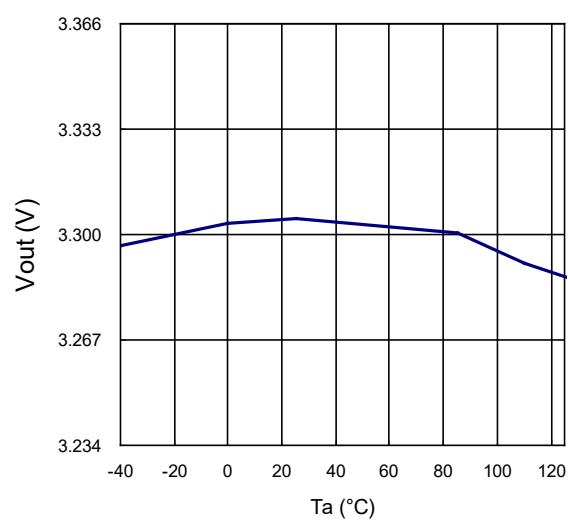

R1517x50xx

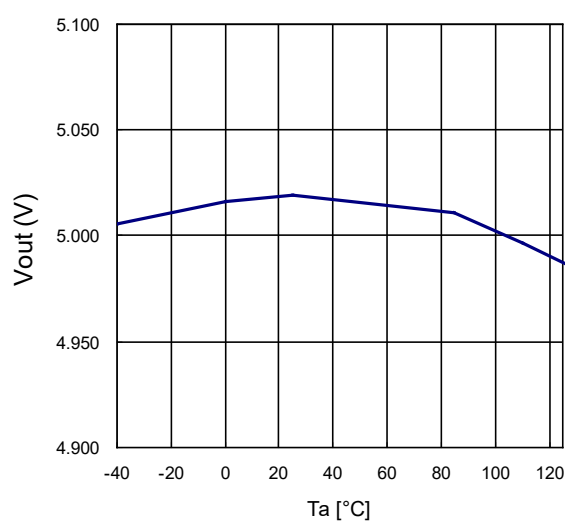

R1517x85xx

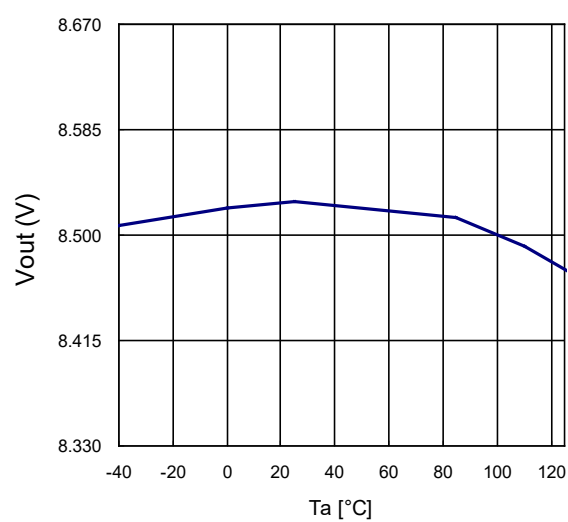

5) Dropout Voltage vs. Output Current

R1517x25xx, R1517x001C

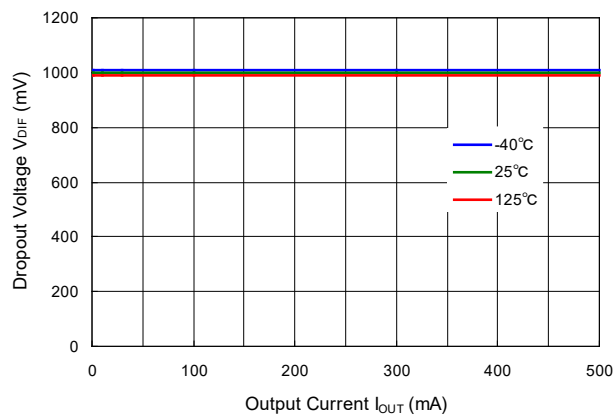

R1517x33xx

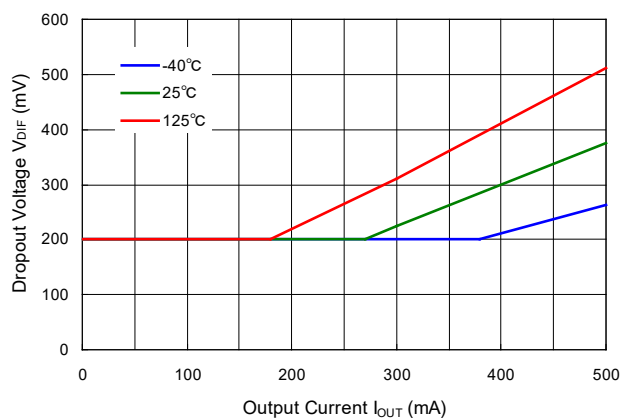

R1517x50xx

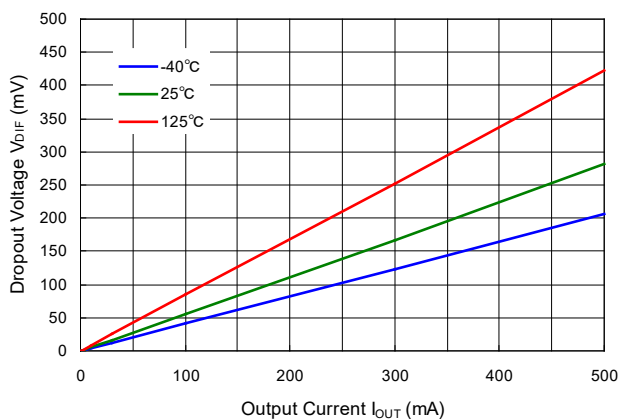

R1517x85xx

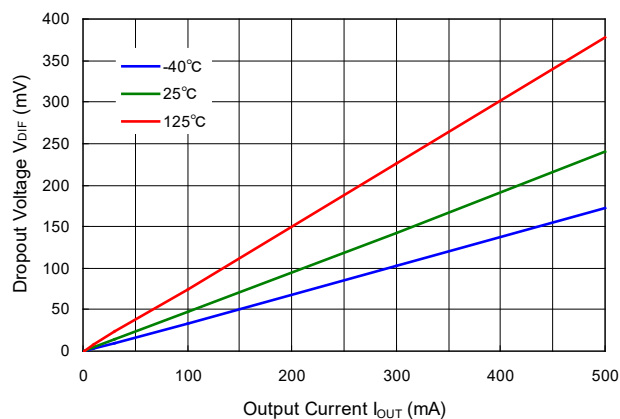

6) Ripple Rejection vs. Input Voltage (Ta = 25°C, Ripple = 0.2 Vpp)

R1517x25xx, R1517x001C (I_OUT = 1 mA)

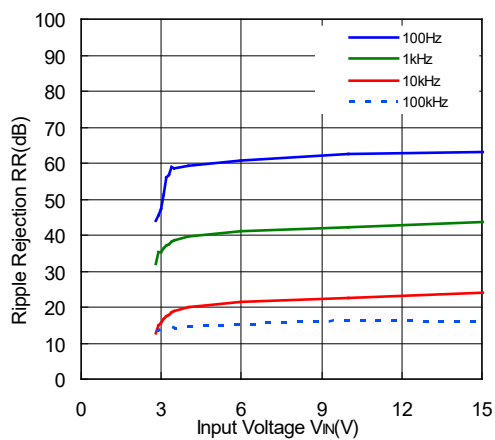

R1517x25xx, R1517x001C (I_OUT = 150 mA)

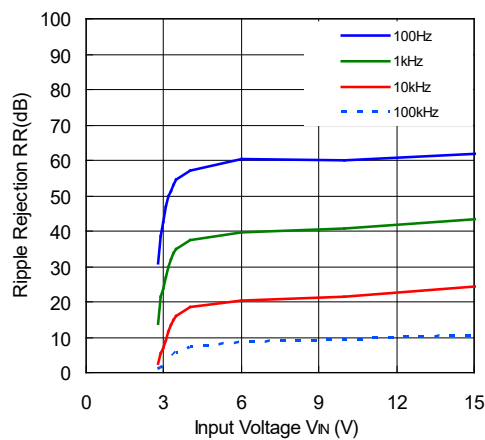

R1517x33xx (I_{OUT} = 1 mA)

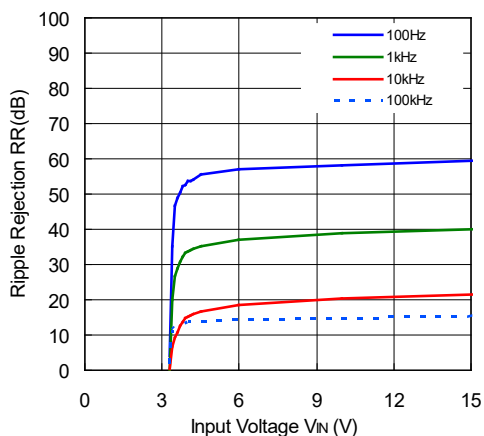

R1517x33xx (I_{OUT} = 150 mA)

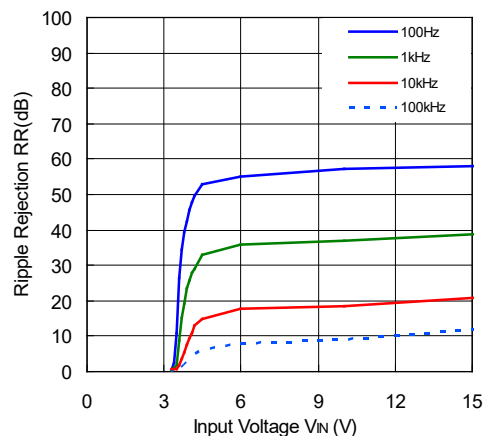

R1517x50xx (I_{OUT} = 1 mA)

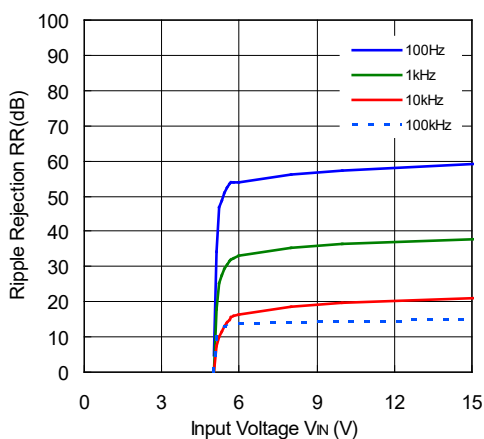

R1517x50xx (I_{OUT} = 150 mA)

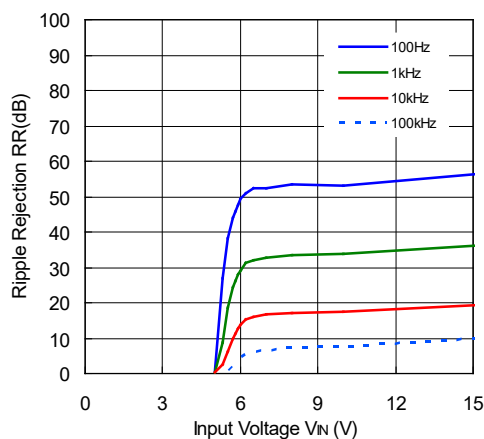

R1517x85xx (I_{OUT} = 1 mA)

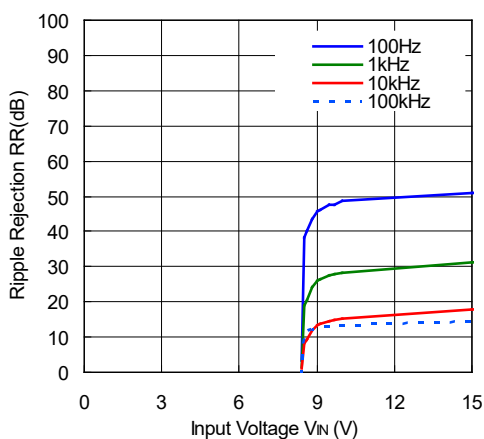

R1517x85xx (I_{OUT} = 150 mA)

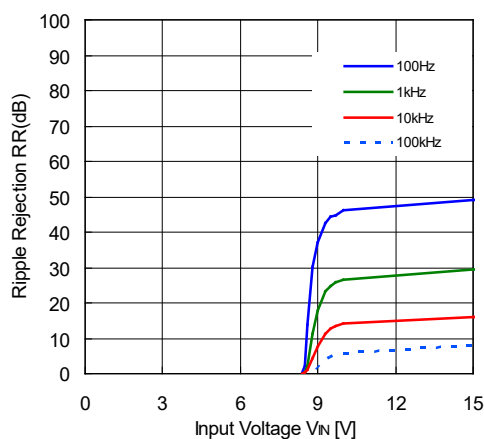

7) Ripple Rejection vs. Frequency ($T_a = 25^\circ\text{C}$, Ripple = 0.2 Vpp)

R1517x25xx, R1517x001C

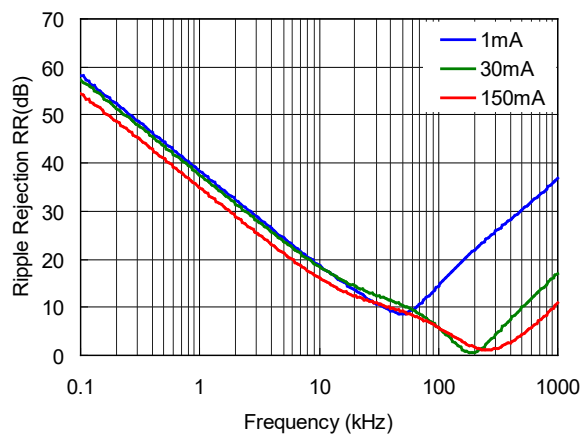

R1517x33xx

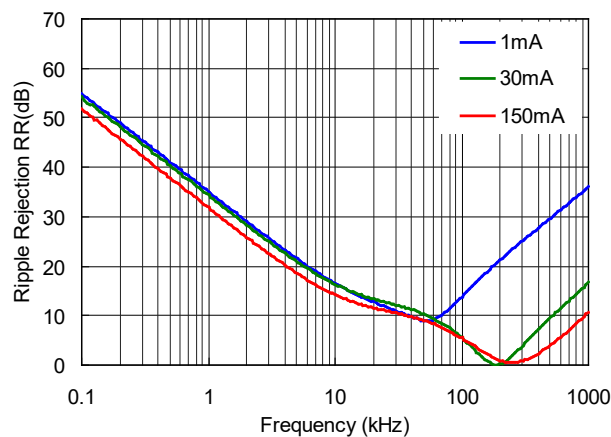

R1517x50xx

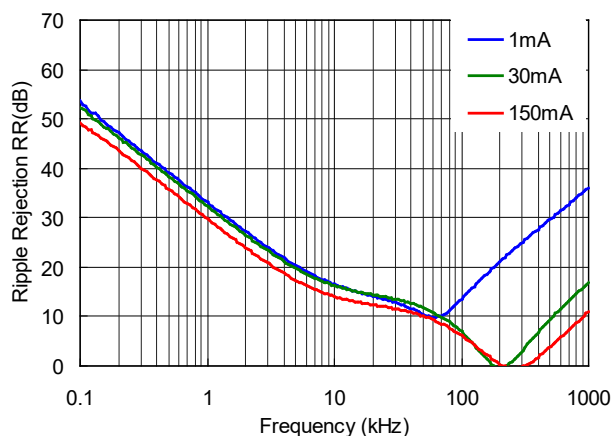

R1517x85xx

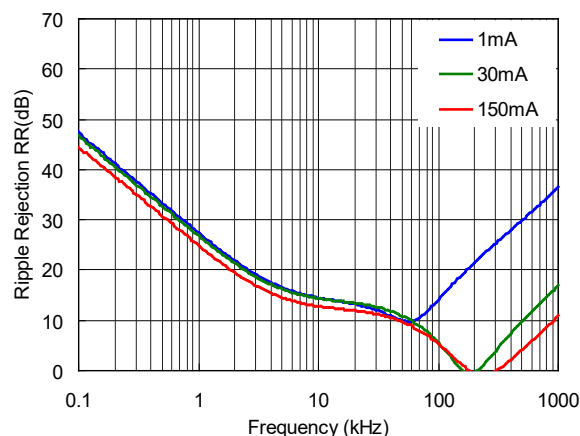

8) Input Transient Response ($T_a = 25^\circ\text{C}$, $I_{OUT} = 1\text{ mA}$, $t_r = t_f = 5\ \mu\text{s}$)

R1517x25xx, R1517x001C ($C_2 = 0.1\ \mu\text{F}$)

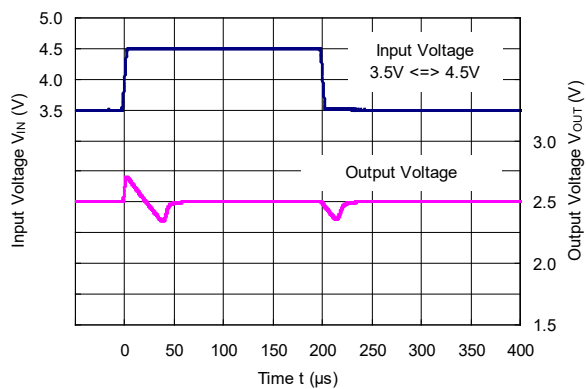

R1517x25xx, R1517x001C ($C_2 = 10\ \mu\text{F}$)

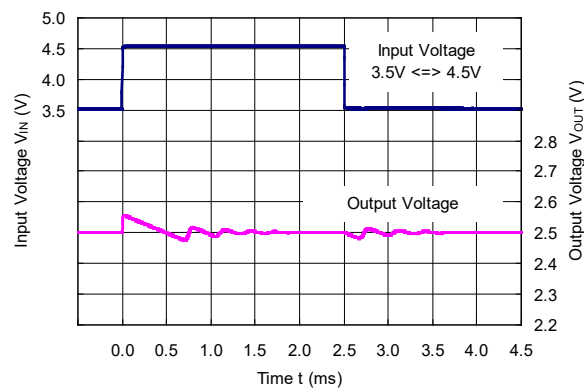

R1517x33xx (C2 = 0.1 μ F)

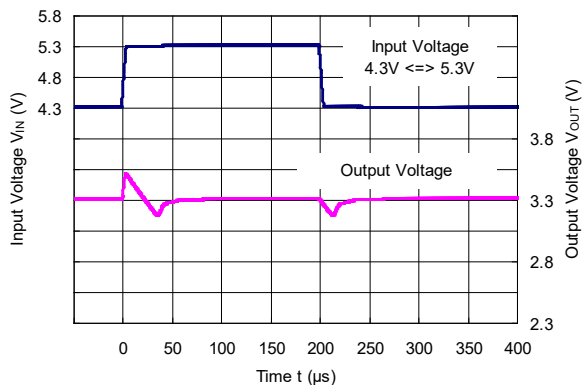

R1517x33xx (C2 = 10 μ F)

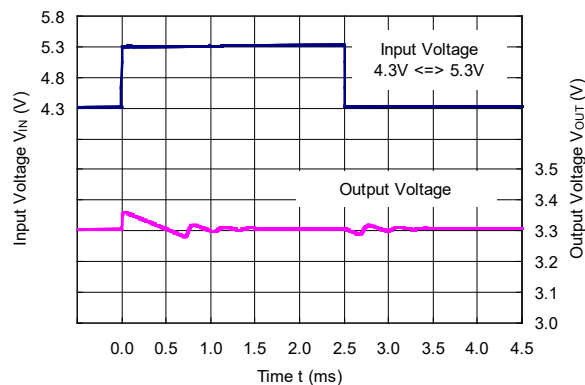

R1517x50xx (C2 = 0.1 μ F)

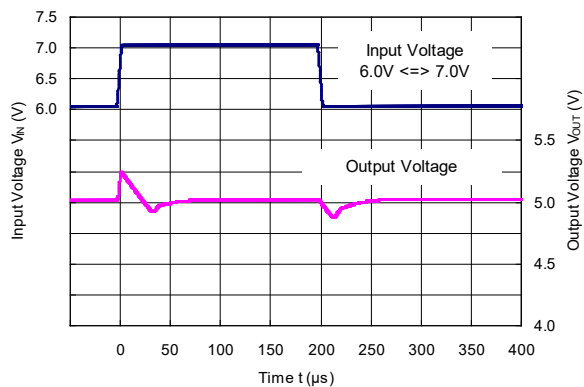

R1517x50xx (C2 = 10 μ F)

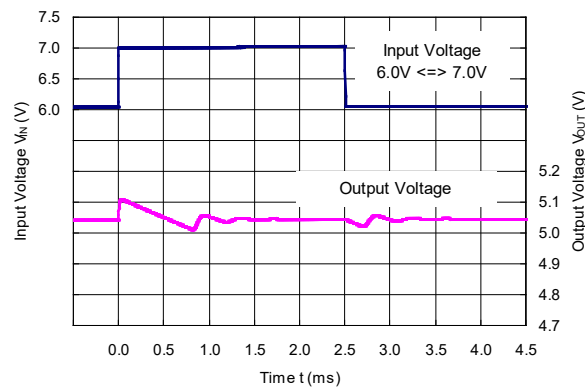

R1517x85xx (C2 = 0.1 μ F)

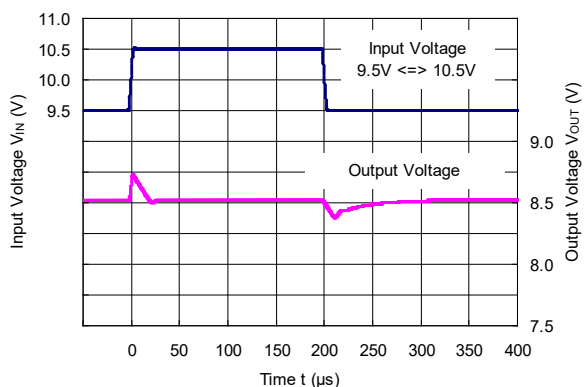

R1517x85xx (C2 = 10 μ F)

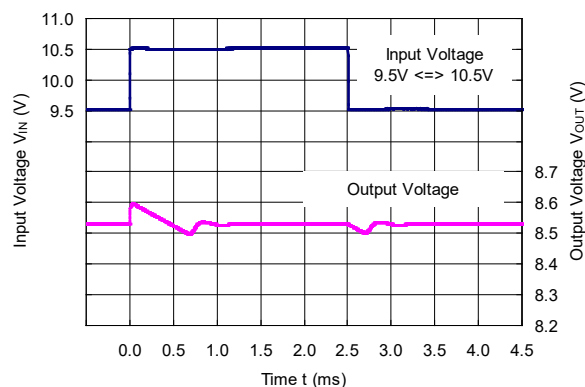

9) Load Transient Response ($T_a = 25^\circ\text{C}$, $V_{IN} = V_{OUT} + 1.0\text{ V}$, $t_r = t_f = 0.5\ \mu\text{s}$)

R1517x25xx, R1517x001C ($C_2 = 0.1\ \mu\text{F}$)

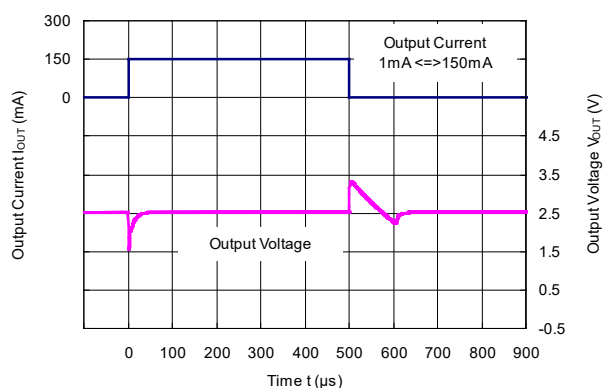

R1517x25xx, R1517x001C ($C_2 = 10\ \mu\text{F}$)

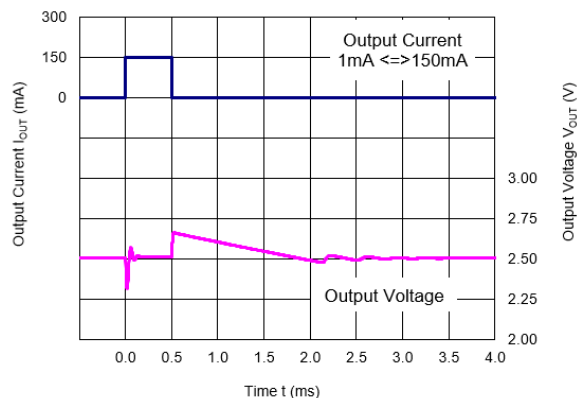

R1517x33xx ($C_2 = 0.1\ \mu\text{F}$)

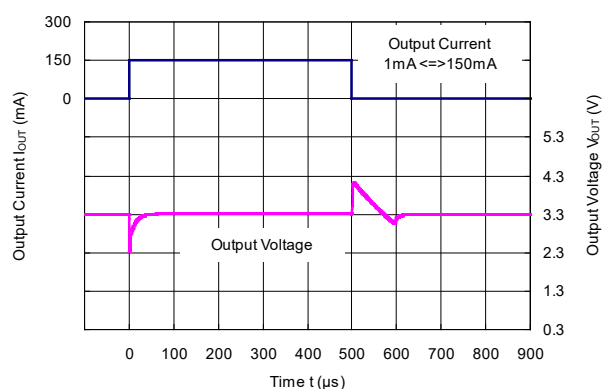

R1517x33xx ($C_2 = 10\ \mu\text{F}$)

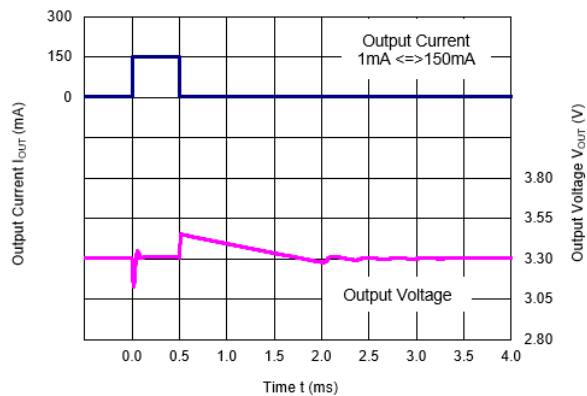

R1517x50xx ($C_2 = 0.1\ \mu\text{F}$)

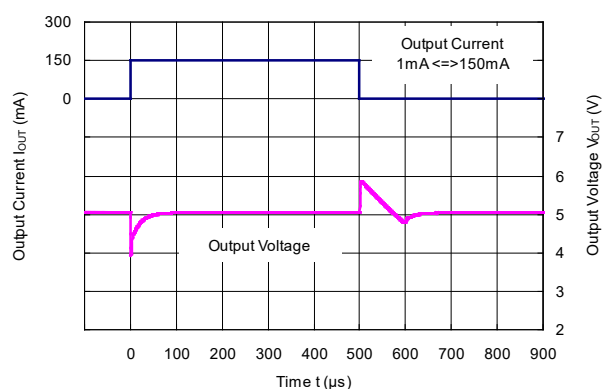

R1517x50xx ($C_2 = 10\ \mu\text{F}$)

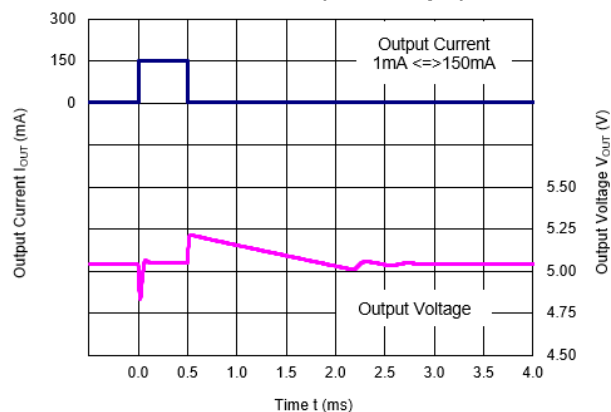

R1517x85xx (C2 = 0.1 μ F)

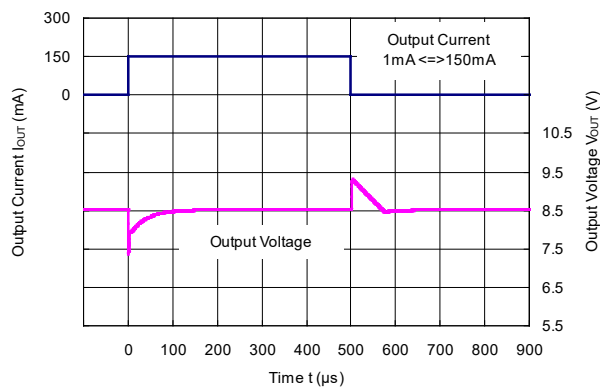

R1517x85xx (C2 = 10 μ F)

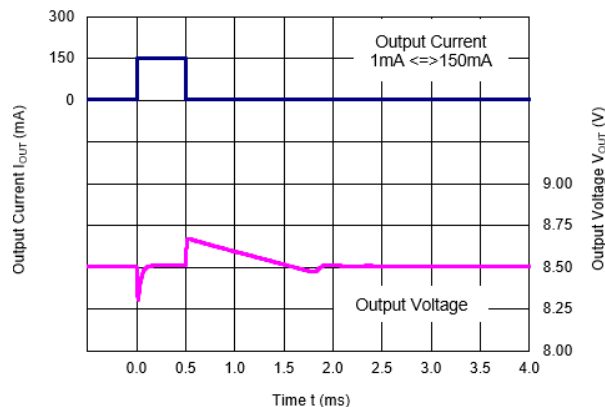

10) CE Transient Response (Ta = 25°C)

R1517x25xB/D, R1517x001C (C2 = 0.1 μ F)

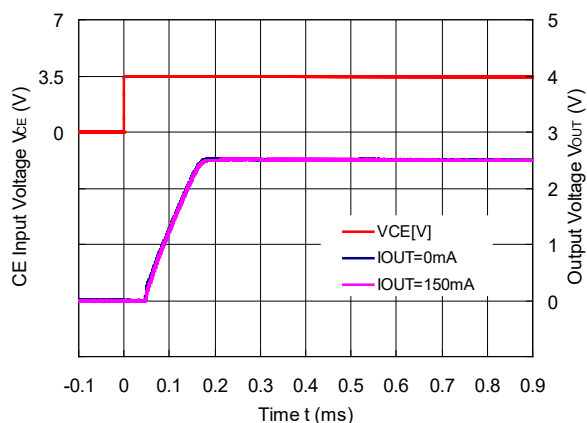

R1517x25xD (C2 = 0.1 μ F)

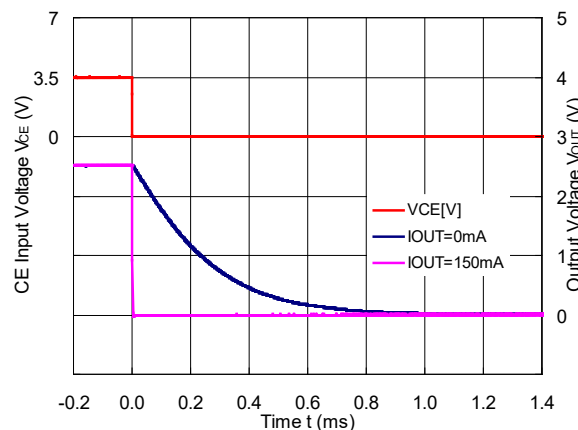

R1517x33xB/D (C2 = 0.1 μ F)

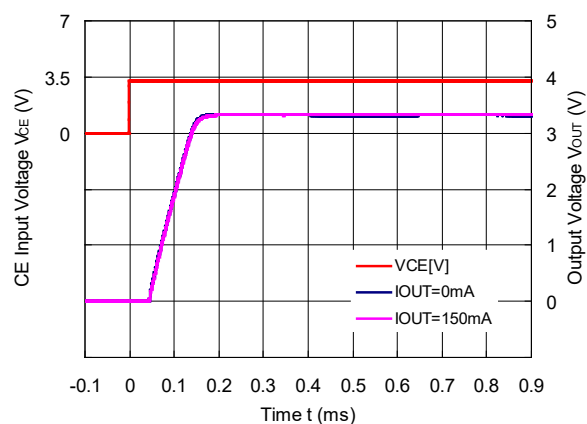

R1517x33xD (C2 = 0.1 μ F)

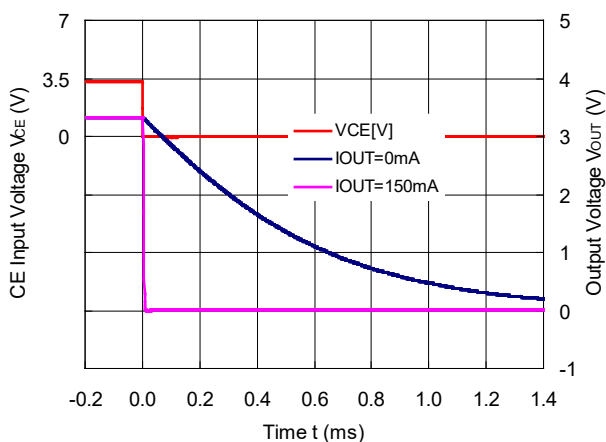

R1517x50xB/D (C2 = 0.1 μF)

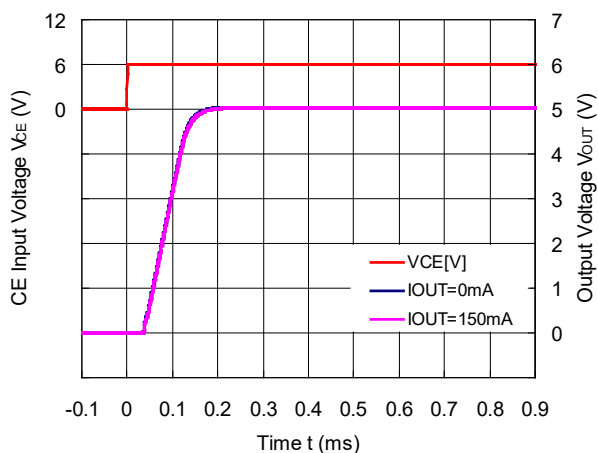

R1517x50xD (C2 = 0.1 μF)

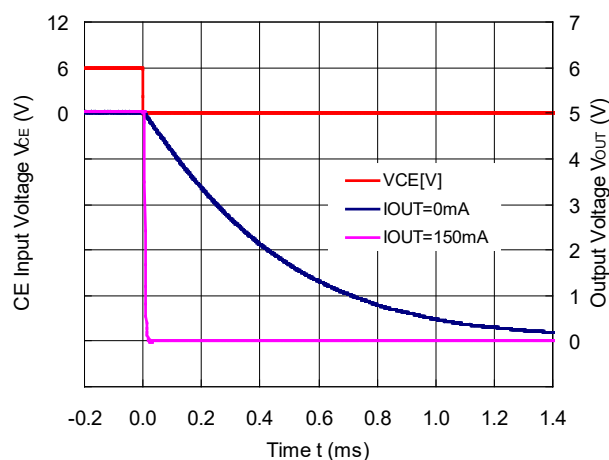

R1517x85xB/D (C2 = 0.1 μF)

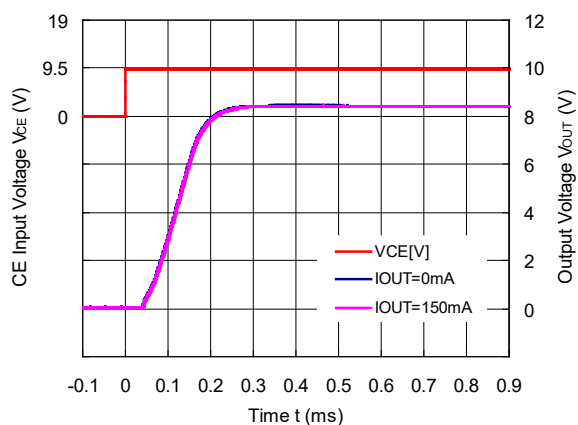

R1517x85xD (C2 = 0.1 μF)

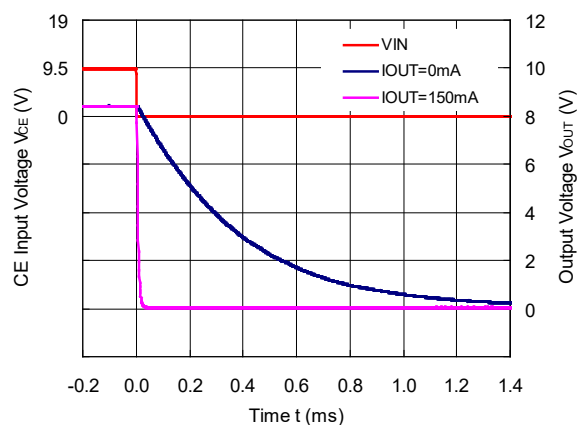

R1517x251E/F (C2 = 0.1 μF, C_D = 1 nF)

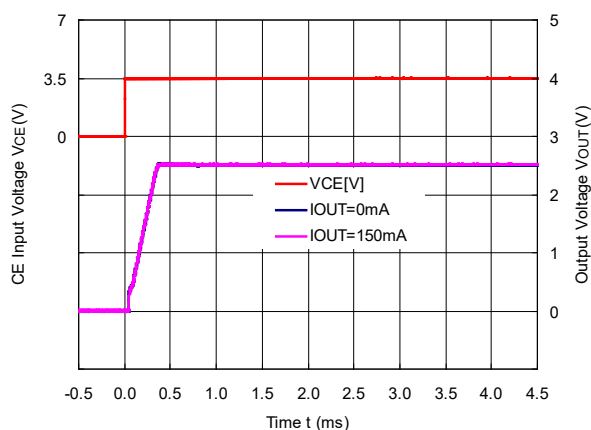

R1517x251F (C2 = 0.1 μF, C_D = 1 nF)

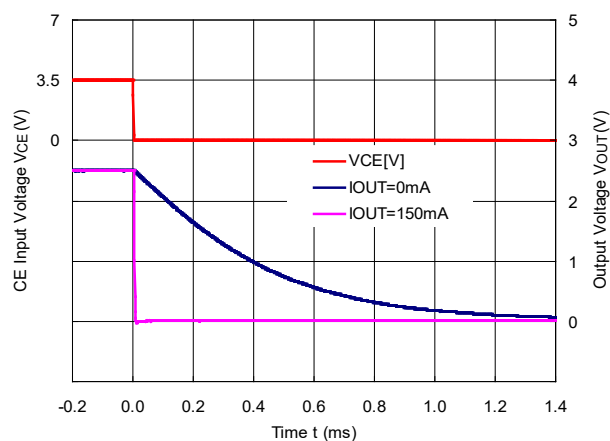

R1517x331E/F (C2 = 0.1 μF, CD = 1 nF)

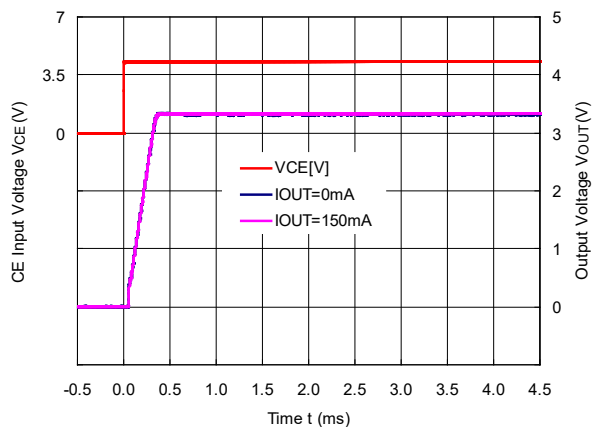

R1517x331F (C2 = 0.1 μF, CD = 1 nF)

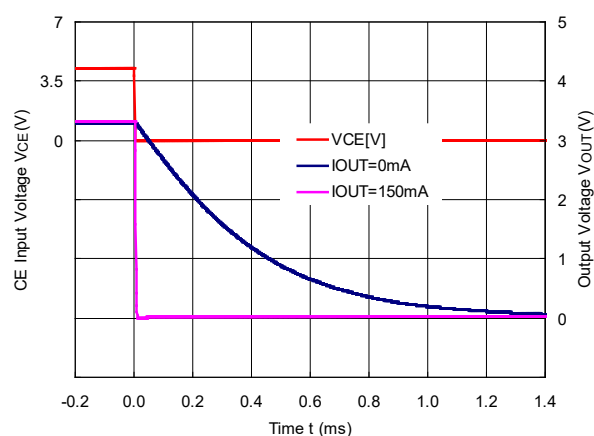

R1517x501E/F (C2 = 0.1 μF, CD = 1 nF)

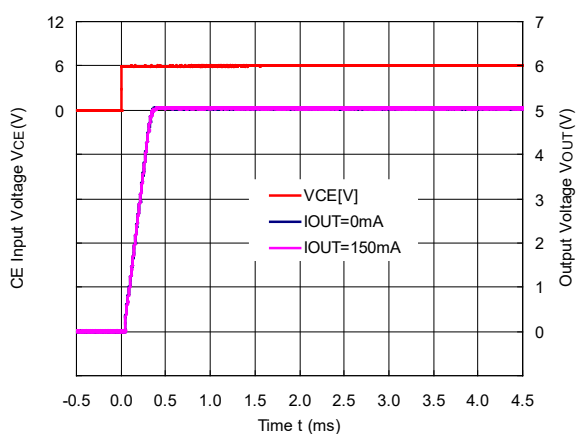

R1517x501F (C2 = 0.1 μF, CD = 1 nF)

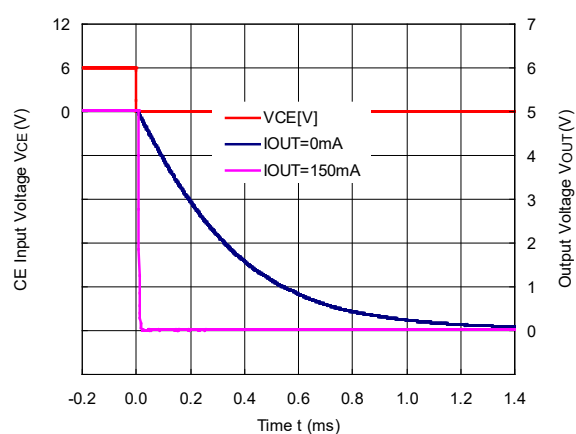

R1517x851E/F (C2 = 0.1 μF, CD = 1 nF)

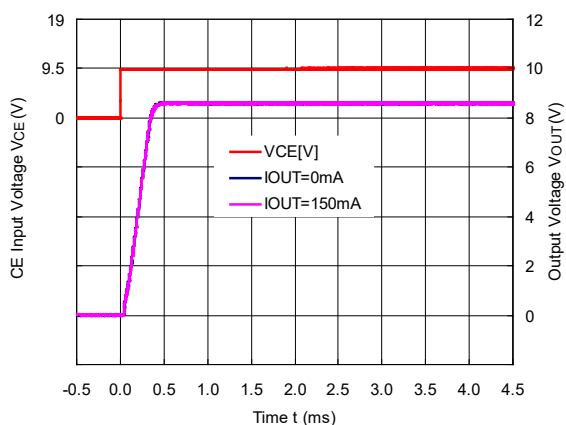

R1517x851F (C2 = 0.1 μF, CD = 1 nF)

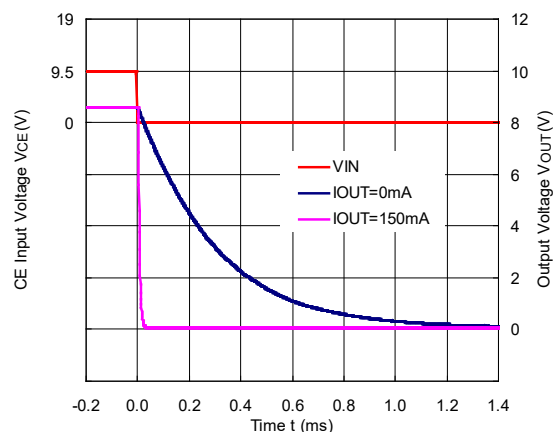

11) Inrush Current Prevention Circuit (Ta = 25°C, I_{OUT} = 1 mA)

R1517x25xB/D, R1517x001C

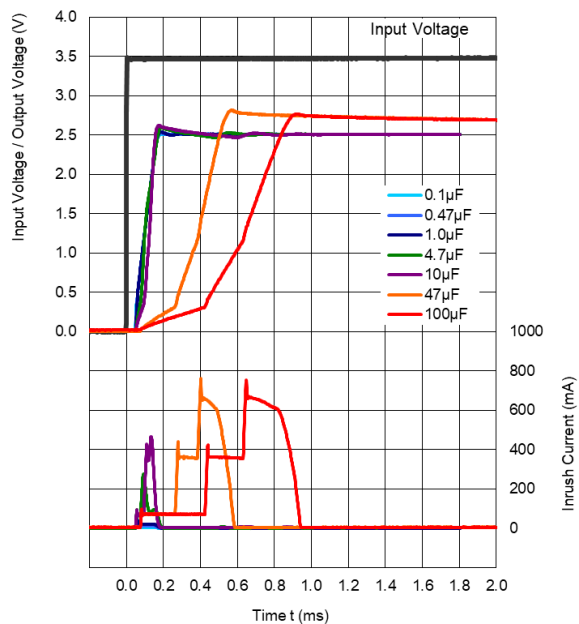

R1517x33xB/D

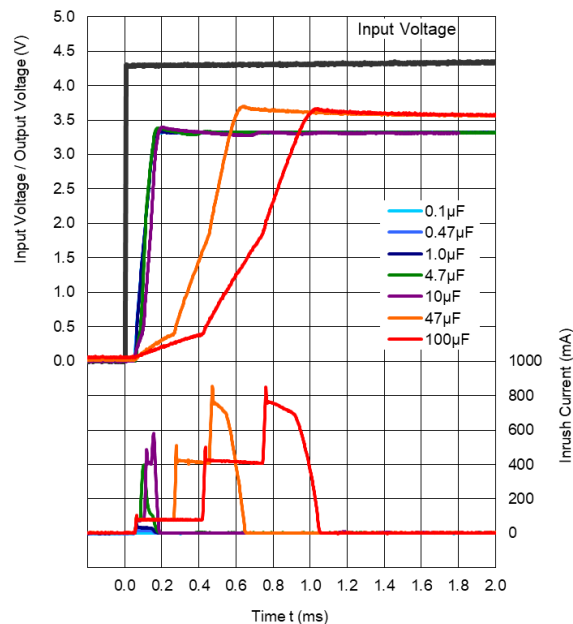

R1517x50xB/D

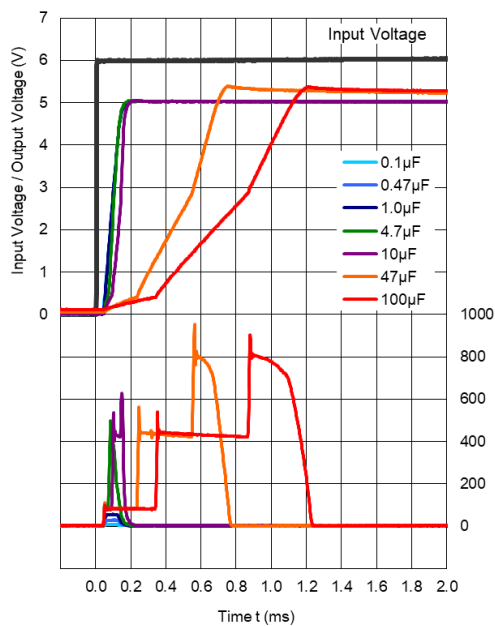

R1517x85xB/D

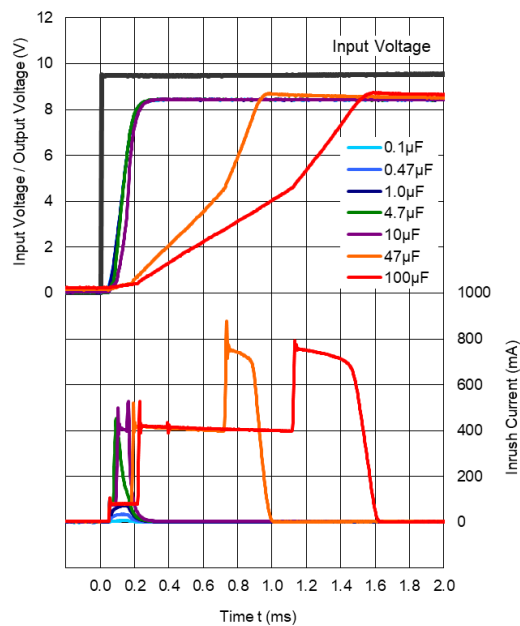

R1517x251E/F ($C_D = 10 \text{ nF}$)

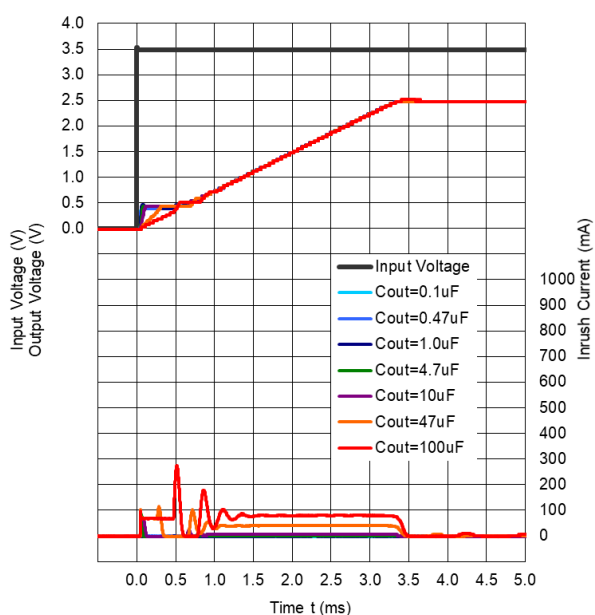

R1517x331E/F ($C_D = 10 \text{ nF}$)

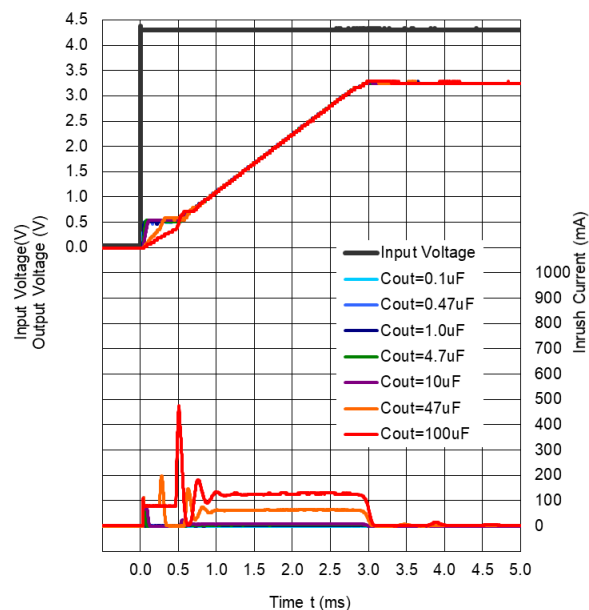

R1517x501E/F ($C_D = 10 \text{ nF}$)

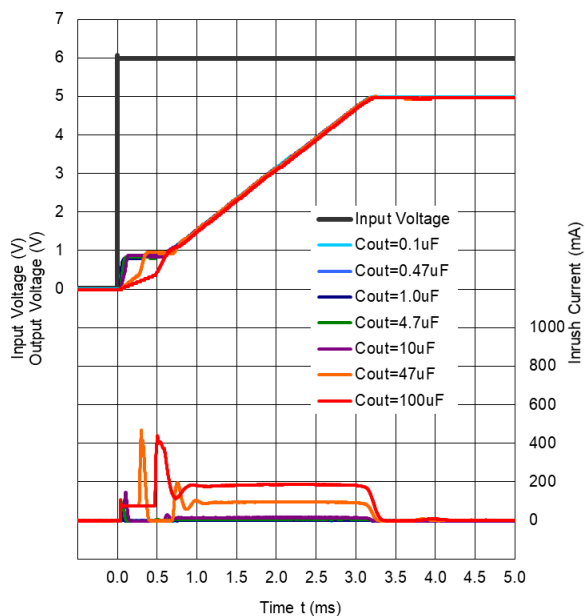

R1517x851E/F ($C_D = 10 \text{ nF}$)

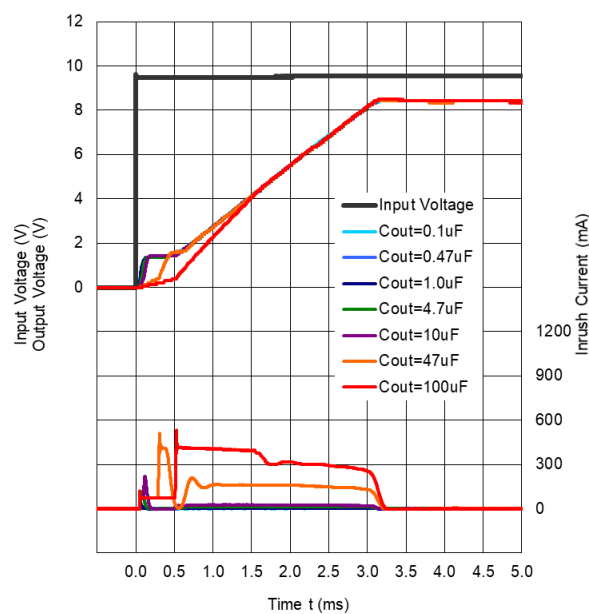

Load Transient vs. Output Capacity (C2)

R1517 performs a stable operation by using 0.1 μF of ceramic capacitor as the output capacitor. However, the variation of output voltage may not meet the demand of the system when input voltage and load current vary. In such cases, the variation of output voltage can be minimized significantly by using 10 μF or higher ceramic capacitor. When using a high-capacity electrolytic capacitor for the output line, place the electrolytic capacitor a few centimeters apart from the IC after arranging the ceramic capacitor close to the IC.

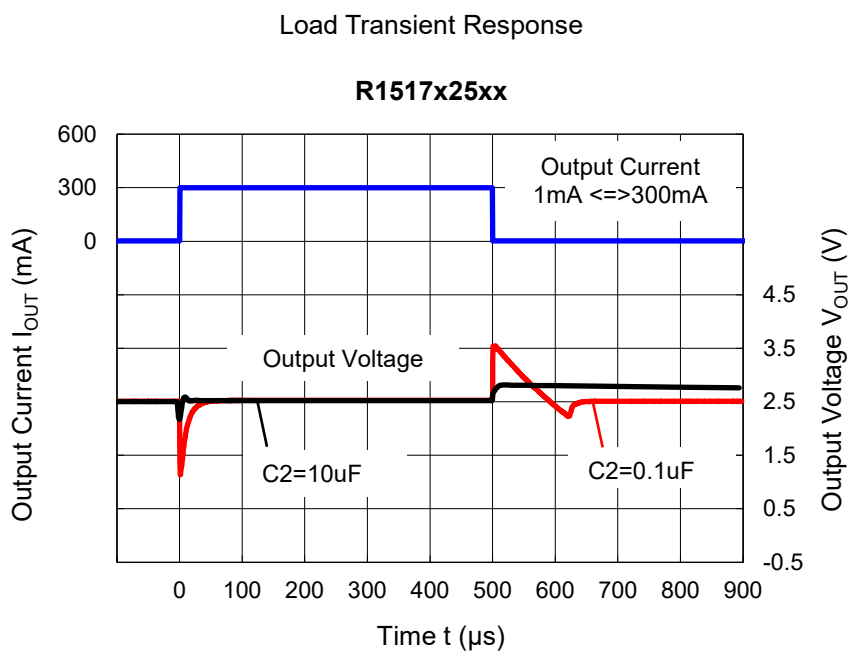

ESR vs. Output Current

It is recommended that a ceramic type capacitor be used for this device. However, other types of capacitors having lower ESR can also be used. The relation between the output current (I_{OUT}) and the ESR of output capacitor is shown below.

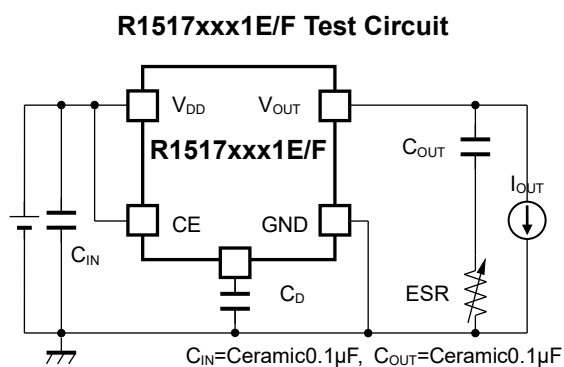
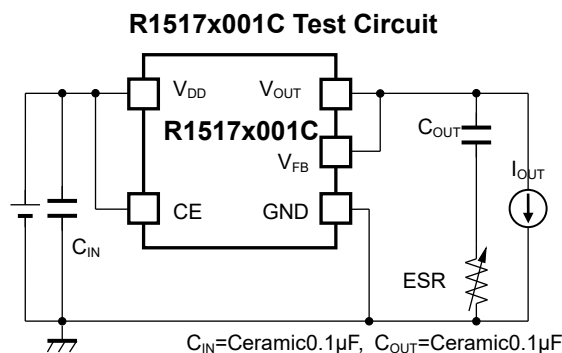
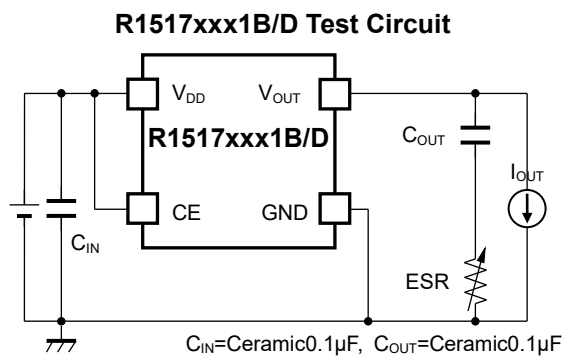

Measurement conditions

Frequency Band: 10 Hz to 2 MHz

Measurement Temperature: -40°C to 125°C

Hatched area: Noise level is $40\mu\text{V}$ (average) or below

Capacitor: C1 = Ceramic $0.1\mu\text{F}$, C2 = $0.1\mu\text{F}$

R1517x25xx Output Current I_{OUT} vs. ESR

$V_{in} = 2.5\text{V to } 36\text{V}$

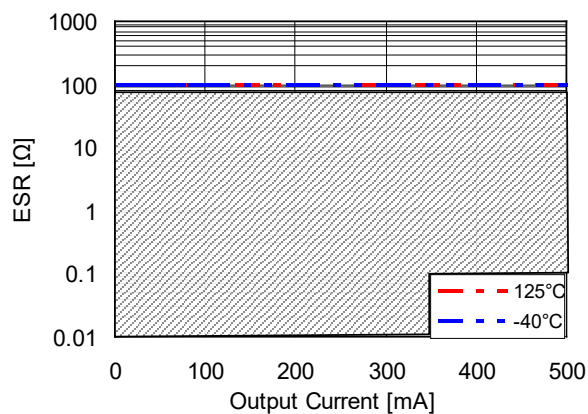

R1517x85xx Output Current I_{OUT} vs. ESR

$V_{in} = 8.5\text{V to } 36\text{V}$

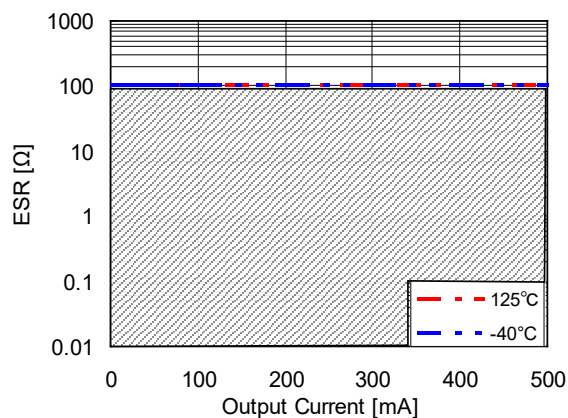

PACKAGE INFORMATION

POWER DISSIPATION (HSOP-6J)

Ver. A

The power dissipation of the package is dependent on PCB material, layout, and environmental conditions. The following measurement conditions are based on JEDEC STD. 51-7.

Measurement Conditions

Item	Measurement Conditions
Environment	Mounting on Board (Wind Velocity = 0 m/s)
Board Material	Glass Cloth Epoxy Plastic (Four-Layer Board)
Board Dimensions	76.2 mm × 114.3 mm × 0.8 mm
Copper Ratio	Outer Layer (First Layer): Less than 95% of 50 mm Square Inner Layers (Second and Third Layers): Approx. 100% of 50 mm Square Outer Layer (Fourth Layer): Approx. 100% of 50 mm Square
Through-holes	φ 0.3 mm × 28 pcs

Measurement Result

(Ta = 25°C, Tjmax = 150°C)

Item	Measurement Result
Power Dissipation	3400 mW
Thermal Resistance (θ_{ja})	$\theta_{ja} = 37^{\circ}\text{C/W}$
Thermal Characterization Parameter (ψ_{jt})	$\psi_{jt} = 7^{\circ}\text{C/W}$

θ_{ja} : Junction-to-Ambient Thermal Resistance

ψ_{jt} : Junction-to-Top Thermal Characterization Parameter

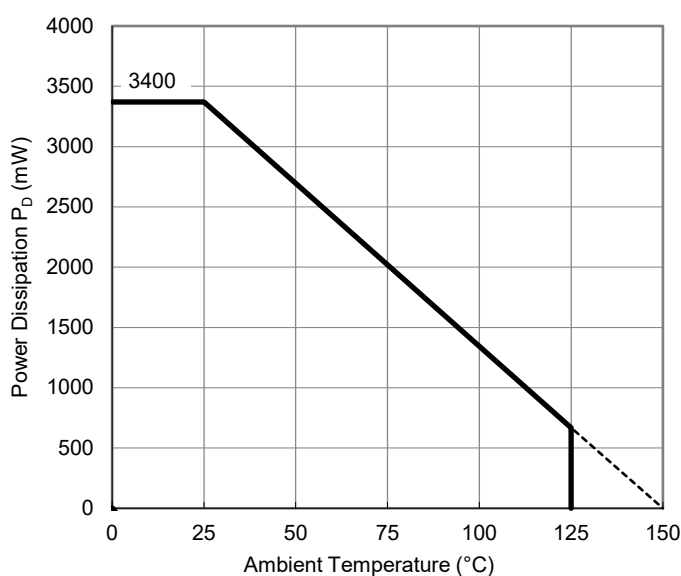

Power Dissipation vs. Ambient Temperature

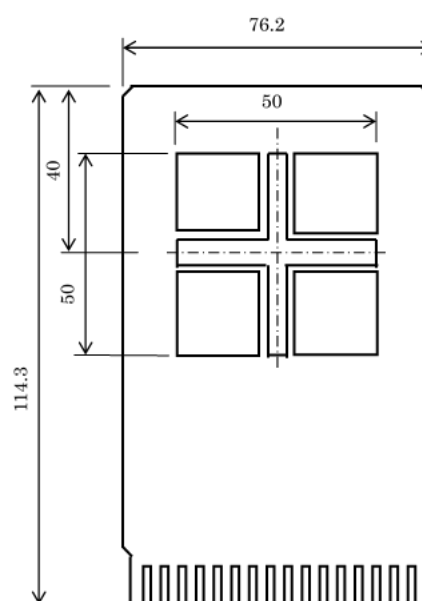

Measurement Board Pattern

PACKAGE DIMENSIONS (HSOP-6J)

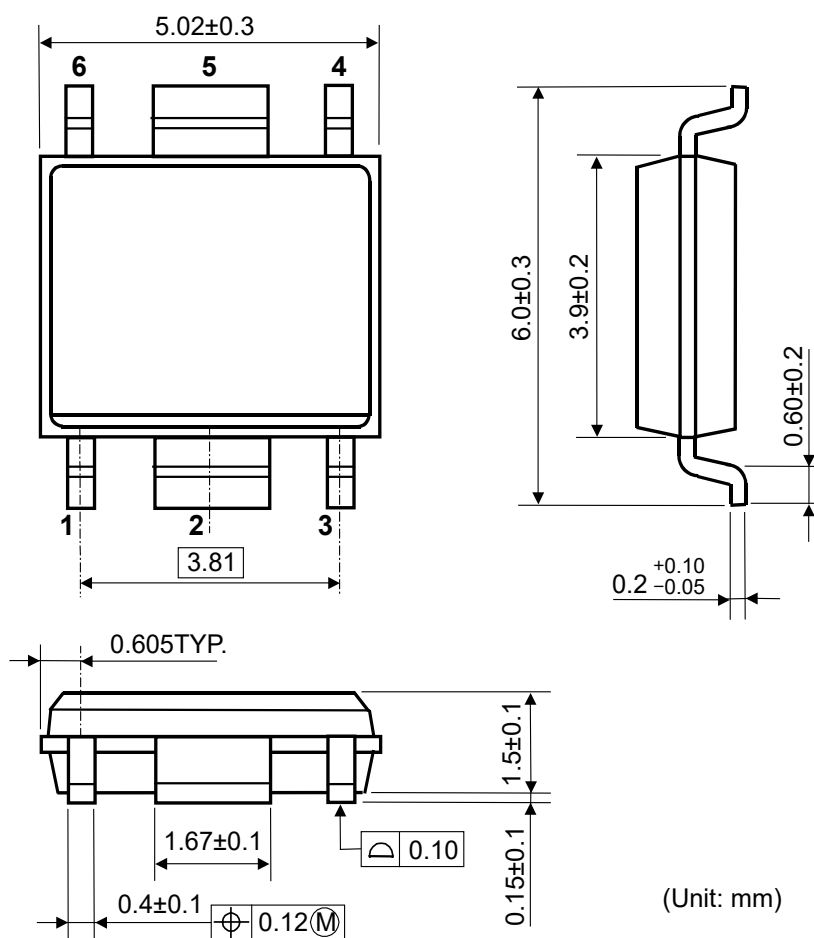

(Unit: mm)

HSOP-6J Package Dimensions

①②③④: Product Code ... Refer to *Part Marking List*

⑤⑥: Lot Number ... Alphanumeric Serial Number

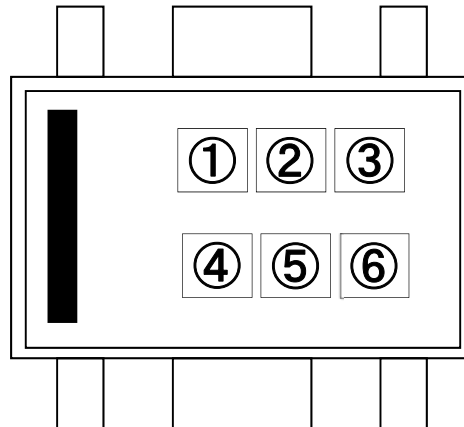

HSOP-6J Part Markings

NOTICE

There can be variation in the marking when different AOI (Automated Optical Inspection) equipment is used. In the case of recognizing the marking characteristic with AOI, please contact our sales or our distributor before attempting to use AOI.

R1517Sxx1/xx2 Part Marking List: Consumer Grade, Industrial Grade, Automotive Grade

*The target product may differ depending on the quality grade. Also, the 001C, xx1x, and xx2x have different pin layouts. Refer to the datasheet for details.

R1517Sxx1B: Consumer Grade, Industrial Grade

Product Name	①②③④	V _{SET}
R1517S251B	V 1 2 5	2.5 V
R1517S331B	V 1 3 3	3.3 V
R1517S341B	V 1 3 4	3.4 V
R1517S501B	V 1 5 0	5.0 V
R1517S851B	V 1 8 5	8.5 V

R1517Sxx1D: Consumer Grade, Industrial Grade

Product Name	①②③④	V _{SET}
R1517S251D	V 3 2 5	2.5 V
R1517S331D	V 3 3 3	3.3 V
R1517S341D	V 3 3 4	3.4 V
R1517S501D	V 3 5 0	5.0 V
R1517S851D	V 3 8 5	8.5 V

R1517Sxx1E: Consumer Grade, Industrial Grade

Product Name	①②③④	V _{SET}
R1517S251E	V 4 2 5	2.5 V
R1517S331E	V 4 3 3	3.3 V
R1517S341E	V 4 3 4	3.4 V
R1517S501E	V 4 5 0	5.0 V
R1517S851E	V 4 8 5	8.5 V

R1517Sxx1F: Consumer Grade, Industrial Grade

Product Name	①②③④	V _{SET}
R1517S251F	V 5 2 5	2.5 V
R1517S331F	V 5 3 3	3.3 V
R1517S341F	V 5 3 4	3.4 V
R1517S501F	V 5 5 0	5.0 V
R1517S851F	V 5 8 5	8.5 V

R1517S001C: Consumer Grade, Industrial Grade, Automotive Grade

Product Name	①②③④	V _{SET}
R1517S001C	V 2 0 1	-

R1517Sxx2B: Automotive Grade

Product Name	①②③④	V _{SET}
R1517S252B	V 6 2 5	2.5 V
R1517S282B	V 6 2 8	2.8 V
R1517S302B	V 6 3 0	3.0 V
R1517S332B	V 6 3 3	3.3 V
R1517S342B	V 6 3 4	3.4 V
R1517S502B	V 6 5 0	5.0 V
R1517S602B	V 6 6 0	6.0 V
R1517S802B	V 6 8 0	8.0 V
R1517S852B	V 6 8 5	8.5 V
R1517S902B	V 6 9 0	9.0 V

R1517Sxx2D: Automotive Grade

Product Name	①②③④	V _{SET}
R1517S252D	V 7 2 5	2.5 V
R1517S282D	V 7 2 8	2.8 V
R1517S302D	V 7 3 0	3.0 V
R1517S332D	V 7 3 3	3.3 V
R1517S342D	V 7 3 4	3.4 V
R1517S502D	V 7 5 0	5.0 V
R1517S602D	V 7 6 0	6.0 V
R1517S802D	V 7 8 0	8.0 V
R1517S852D	V 7 8 5	8.5 V
R1517S902D	V 7 9 0	9.0 V

POWER DISSIPATION (TO-252-5-P2)

Ver. A

The power dissipation of the package is dependent on PCB material, layout, and environmental conditions. The following measurement conditions are based on JEDEC STD. 51-7.

Measurement Conditions

Item	Measurement Conditions
Environment	Mounting on Board (Wind Velocity = 0 m/s)
Board Material	Glass Cloth Epoxy Plastic (Four-Layer Board)
Board Dimensions	76.2 mm × 114.3 mm × 0.8 mm
Copper Ratio	Outer Layer (First Layer): Less than 95% of 50 mm Square Inner Layers (Second and Third Layers): Approx. 100% of 50 mm Square Outer Layer (Fourth Layer): Approx. 100% of 50 mm Square
Through-holes	φ 0.3 mm × 21 pcs

Measurement Result

(Ta = 25°C, Tjmax = 150°C)

Item	Measurement Result
Power Dissipation	4800 mW
Thermal Resistance (θ_{ja})	$\theta_{ja} = 26^{\circ}\text{C/W}$
Thermal Characterization Parameter (ψ_{jt})	$\psi_{jt} = 7^{\circ}\text{C/W}$

θ_{ja} : Junction-to-Ambient Thermal Resistance

ψ_{jt} : Junction-to-Top Thermal Characterization Parameter

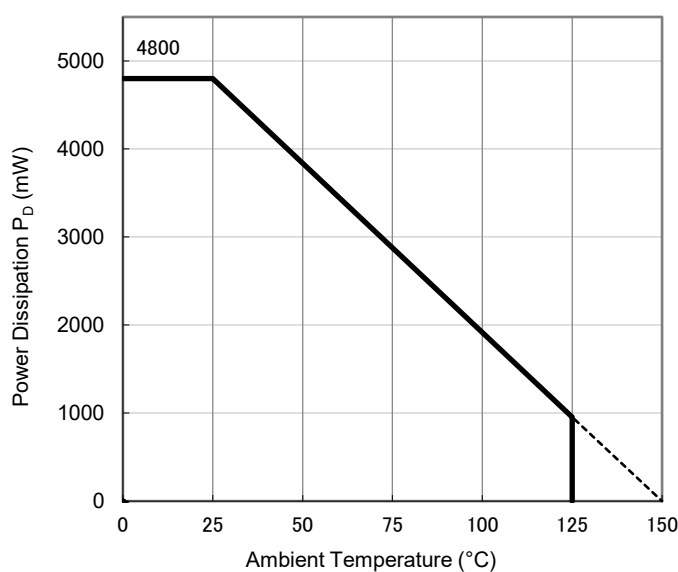
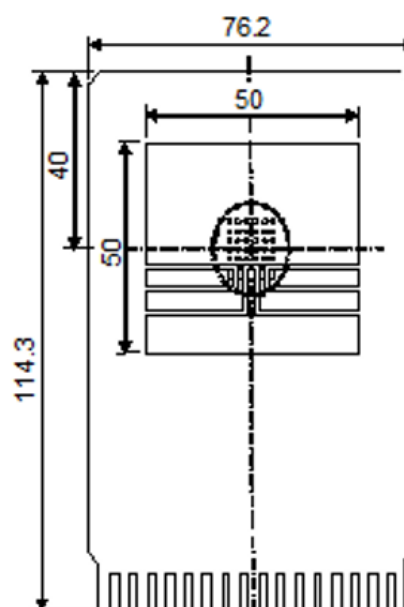
**Power Dissipation vs. Ambient Temperature****Measurement Board Pattern**

PACKAGE DIMENSIONS (TO-252-5-P2)

Ver. A

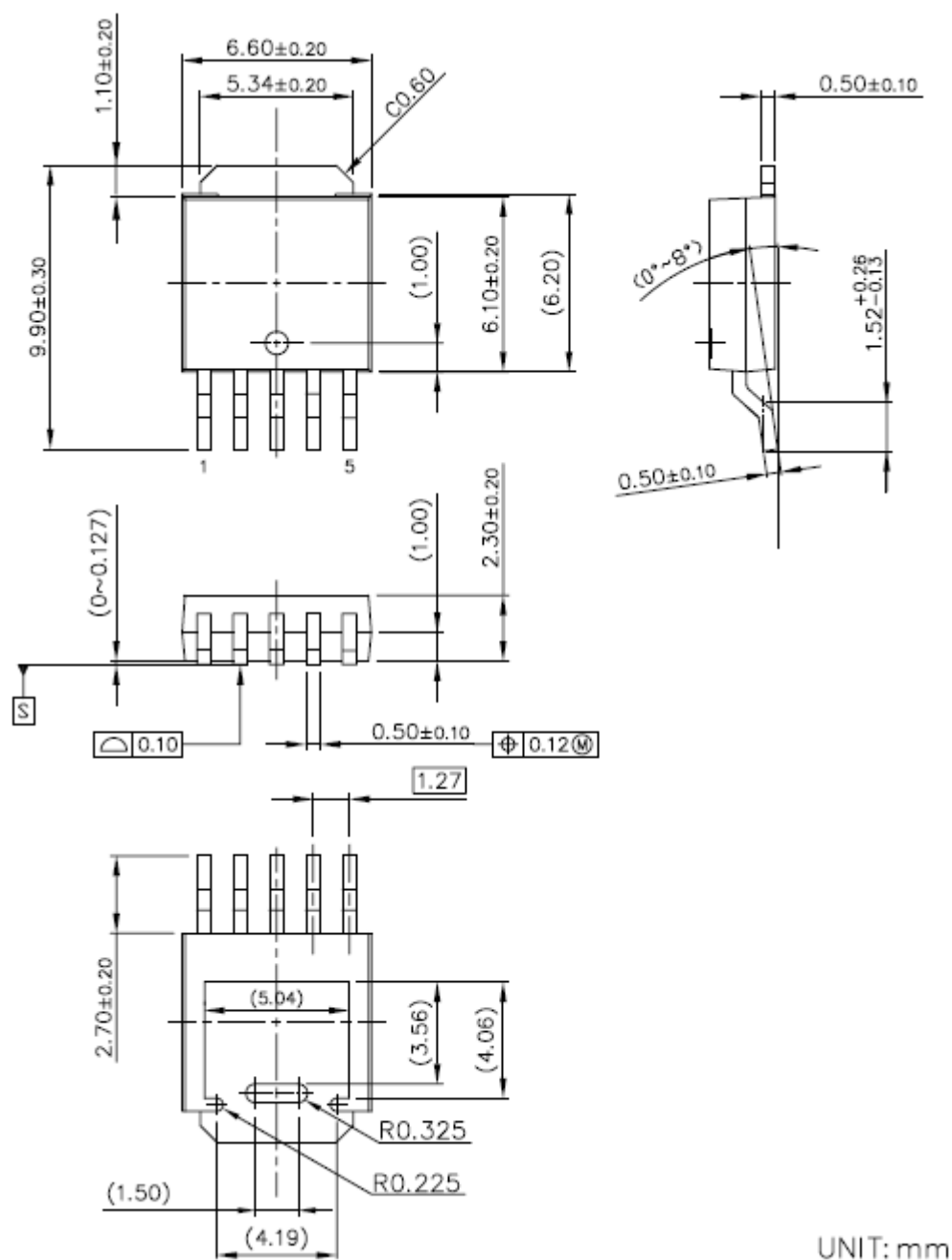

TO-252-5-P2 Package Dimensions

①②③④⑤⑥⑦⑧: Product Code ... Refer to *Part Marking List*

⑨⑩: Lot Number ... Alphanumeric Serial Number

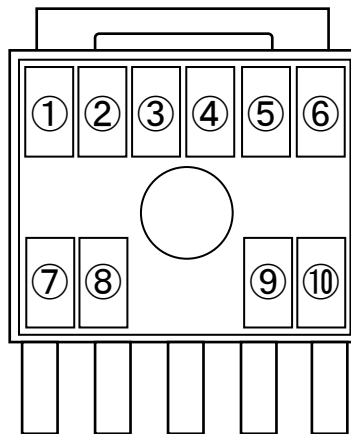

TO-252-5-P2 Part Markings

NOTICE

There can be variation in the marking when different AOI (Automated Optical Inspection) equipment is used. In the case of recognizing the marking characteristic with AOI, please contact our sales or our distributor before attempting to use AOI.

PART MARKINGS

R1517J

MK-R1517J-E-B

R1517Jxxxx Part Marking List: Consumer Grade, Industrial Grade, Automotive Grade*

R1517Jxx1B

Product Name	①②③④⑤⑥⑦⑧	V _{SET}
R1517J251B	K 1 J 2 5 1 B_	2.5 V
R1517J281B	K 1 J 2 8 1 B_	2.8 V
R1517J301B	K 1 J 3 0 1 B_	3.0 V
R1517J331B	K 1 J 3 3 1 B_	3.3 V
R1517J341B	K 1 J 3 4 1 B_	3.4 V
R1517J501B	K 1 J 5 0 1 B_	5.0 V
R1517J601B	K 1 J 6 0 1 B_	6.0 V
R1517J801B	K 1 J 8 0 1 B_	8.0 V
R1517J851B	K 1 J 8 5 1 B_	8.5 V

R1517J001C (Adjustable Output Voltage Setting Type)

Product Name	①②③④⑤⑥⑦⑧	V _{SET}
R1517J001C	K 2 J 0 0 1 C_	-

R1517Jxx1D

Product Name	①②③④⑤⑥⑦⑧	V _{SET}
R1517J251D	K 3 J 2 5 1 D_	2.5 V
R1517J281D	K 3 J 2 8 1 D_	2.8 V
R1517J301D	K 3 J 3 0 1 D_	3.0 V
R1517J331D	K 3 J 3 3 1 D_	3.3 V
R1517J341D	K 3 J 3 4 1 D_	3.4 V
R1517J501D	K 3 J 5 0 1 D_	5.0 V
R1517J601D	K 3 J 6 0 1 D_	6.0 V
R1517J801D	K 3 J 8 0 1 D_	8.0 V
R1517J851D	K 3 J 8 5 1 D_	8.5 V
R1517J901D	K 3 J 9 0 1 D_	9.0 V

R1517Jxx1E

Product Name	①②③④⑤⑥⑦⑧	V _{SET}
R1517J251E	K 4 J 2 5 1 E_	2.5 V
R1517J281E	K 4 J 2 8 1 E_	2.8 V
R1517J301E	K 4 J 3 0 1 E_	3.0 V
R1517J331E	K 4 J 3 3 1 E_	3.3 V
R1517J341E	K 4 J 3 4 1 E_	3.4 V
R1517J501E	K 4 J 5 0 1 E_	5.0 V
R1517J601E	K 4 J 6 0 1 E_	6.0 V
R1517J801E	K 4 J 8 0 1 E_	8.0 V
R1517J851E	K 4 J 8 5 1 E_	8.5 V
R1517J901E	K 4 J 9 0 1 E_	9.0 V

R1517Jxx1F

Product Name	①②③④⑤⑥⑦⑧	V _{SET}
R1517J251F	K 5 J 2 5 1 F_	2.5 V
R1517J281F	K 5 J 2 8 1 F_	2.8 V
R1517J301F	K 5 J 3 0 1 F_	3.0 V
R1517J331F	K 5 J 3 3 1 F_	3.3 V
R1517J341F	K 5 J 3 4 1 F_	3.4 V
R1517J501F	K 5 J 5 0 1 F_	5.0 V
R1517J601F	K 5 J 6 0 1 F_	6.0 V
R1517J801F	K 5 J 8 0 1 F_	8.0 V
R1517J851F	K 5 J 8 5 1 F_	8.5 V
R1517J901F	K 5 J 9 0 1 F_	9.0 V

* The target product may differ depending on the quality grade. Refer to the datasheet for details.

1. The products and the product specifications described in this document are subject to change or discontinuation of production without notice for reasons such as improvement. Therefore, before deciding to use the products, please refer to our sales representatives for the latest information thereon.
2. The materials in this document may not be copied or otherwise reproduced in whole or in part without the prior written consent of us.
3. This product and any technical information relating thereto are subject to complementary export controls (so-called KNOW controls) under the Foreign Exchange and Foreign Trade Law, and related politics ministerial ordinance of the law. (Note that the complementary export controls are inapplicable to any application-specific products, except rockets and pilotless aircraft, that are insusceptible to design or program changes.) Accordingly, when exporting or carrying abroad this product, follow the Foreign Exchange and Foreign Trade Control Law and its related regulations with respect to the complementary export controls.
4. The technical information described in this document shows typical characteristics and example application circuits for the products. The release of such information is not to be construed as a warranty of or a grant of license under our or any third party's intellectual property rights or any other rights.
5. The products listed in this document are intended and designed for use as general electronic components in standard applications (office equipment, telecommunication equipment, measuring instruments, consumer electronic products, amusement equipment etc.). Those customers intending to use a product in an application requiring extreme quality and reliability, for example, in a highly specific application where the failure or misoperation of the product could result in human injury or death should first contact us.
 - Aerospace Equipment
 - Equipment Used in the Deep Sea
 - Power Generator Control Equipment (nuclear, steam, hydraulic, etc.)
 - Life Maintenance Medical Equipment
 - Fire Alarms / Intruder Detectors
 - Vehicle Control Equipment (automotive, airplane, railroad, ship, etc.)
 - Various Safety Devices
 - Traffic control system
 - Combustion equipment

In case your company desires to use this product for any applications other than general electronic equipment mentioned above, make sure to contact our company in advance. Note that the important requirements mentioned in this section are not applicable to cases where operation requirements such as application conditions are confirmed by our company in writing after consultation with your company.

6. We are making our continuous effort to improve the quality and reliability of our products, but semiconductor products are likely to fail with certain probability. In order to prevent any injury to persons or damages to property resulting from such failure, customers should be careful enough to incorporate safety measures in their design, such as redundancy feature, fire containment feature and fail-safe feature. We do not assume any liability or responsibility for any loss or damage arising from misuse or inappropriate use of the products.
7. The products have been designed and tested to function within controlled environmental conditions. Do not use products under conditions that deviate from methods or applications specified in this datasheet. Failure to employ the products in the proper applications can lead to deterioration, destruction or failure of the products. We shall not be responsible for any bodily injury, fires or accident, property damage or any consequential damages resulting from misuse or misapplication of the products.
8. **Quality Warranty**
 - 8-1. **Quality Warranty Period**

In the case of a product purchased through an authorized distributor or directly from us, the warranty period for this product shall be one (1) year after delivery to your company. For defective products that occurred during this period, we will take the quality warranty measures described in section 8-2. However, if there is an agreement on the warranty period in the basic transaction agreement, quality assurance agreement, delivery specifications, etc., it shall be followed.
 - 8-2. **Quality Warranty Remedies**

When it has been proved defective due to manufacturing factors as a result of defect analysis by us, we will either deliver a substitute for the defective product or refund the purchase price of the defective product.

Note that such delivery or refund is sole and exclusive remedies to your company for the defective product.
 - 8-3. **Remedies after Quality Warranty Period**

With respect to any defect of this product found after the quality warranty period, the defect will be analyzed by us. On the basis of the defect analysis results, the scope and amounts of damage shall be determined by mutual agreement of both parties. Then we will deal with upper limit in Section 8-2. This provision is not intended to limit any legal rights of your company.
9. Anti-radiation design is not implemented in the products described in this document.
10. The X-ray exposure can influence functions and characteristics of the products. Confirm the product functions and characteristics in the evaluation stage.
11. WLCSP products should be used in light shielded environments. The light exposure can influence functions and characteristics of the products under operation or storage.
12. Warning for handling Gallium and Arsenic (GaAs) products (Applying to GaAs MMIC, Photo Reflector). These products use Gallium (Ga) and Arsenic (As) which are specified as poisonous chemicals by law. For the prevention of a hazard, do not burn, destroy, or process chemically to make them as gas or power. When the product is disposed of, please follow the related regulation and do not mix this with general industrial waste or household waste.
13. Please contact our sales representatives should you have any questions or comments concerning the products or the technical information.



Nisshinbo Micro Devices Inc.

Official website

<https://www.nisshinbo-microdevices.co.jp/en/>

Purchase information

<https://www.nisshinbo-microdevices.co.jp/en/buy/>