

BLOCK DIAGRAMS

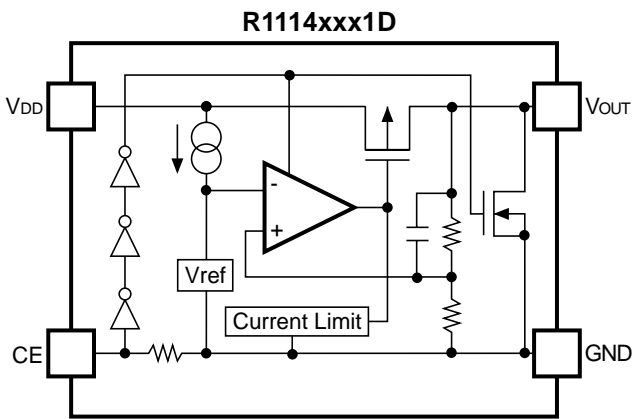
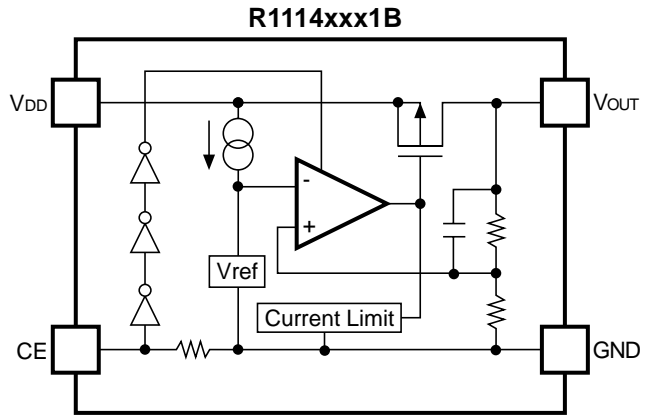
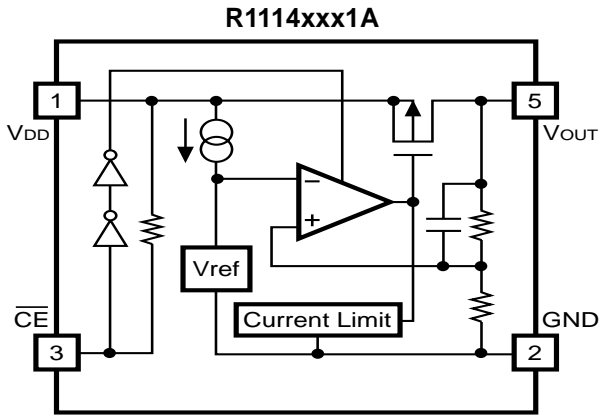

SELECTION GUIDE

The output voltage, auto discharge function, and the taping type, etc. for the ICs can be selected at the user's request.

Product Name	Package	Quantity per Reel	Pb Free	Halogen Free
R1114Nxx1*-TR-#E	SOT-23-5	3,000 pcs	Yes	Yes
xx: The output voltage can be designated in the range from 1.5V(15) to 4.0V(40) in 0.1V steps. (For other voltages, please refer to <i>MARK SPECIFICATION TABLE</i>)				
* : CE pin polarity and auto discharge function at off state are options as follows. (A) "L" active, without auto discharge function at off state (B) "H" active, without auto discharge function at off state (D) "H" active, with auto discharge function at off state				
# : Specify Automotive Class Code				
	Operating Temperature Range	Guaranteed Specs Temperature Range	Screening	
A	-40°C to 85°C	25°C	High Temperature	

* Auto-discharge function quickly lowers the output voltage to 0V, when the chip enable signal is switched from the active mode to the standby mode, by releasing the electrical charge accumulated in the external capacitor.

PIN DESCRIPTIONS

● SOT-23-5

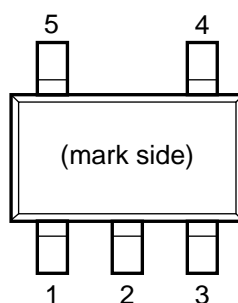

● R1114N

Pin No.	Symbol	Description
1	V _{DD}	Input Pin
2	GND	Ground Pin
3	$\overline{\text{CE}}$ or CE	Chip Enable Pin
4	NC	No Connection
5	V _{OUT}	Output pin

ABSOLUTE MAXIMUM RATINGS

Symbol	Item	Rating	Unit
V_{IN}	Input Voltage	6.5	V
V_{CE}	Input Voltage (\overline{CE} or CE Pin)	6.5	V
V_{OUT}	Output Voltage	$-0.3 \sim V_{IN} + 0.3$	V
I_{OUT}	Output Current	200	mA
P_D	Power Dissipation (SOT-23-5) *	420	mW
T_j	Junction Temperature	$-40 \sim 125$	$^{\circ}\text{C}$
T_{stg}	Storage Temperature Range	$-55 \sim 125$	$^{\circ}\text{C}$

*) Refer to *PACKAGE INFORMATION* for detailed information.

ABSOLUTE MAXIMUM RATINGS

Electronic and mechanical stress momentarily exceeded absolute maximum ratings may cause the permanent damages and may degrade the life time and safety for both device and system using the device in the field. The functional operation at or over these absolute maximum ratings is not assured.

RECOMMENDED OPERATING RATINGS

Symbol	Item	Rating	Unit
V_{IN}	Input Voltage	2.0 to 6	V
T_a	Operating Temperature Range	-40 to 85	$^{\circ}\text{C}$

RECOMMENDED OPERATING RATINGS

All of electronic equipment should be designed that the mounted semiconductor devices operate within the recommended operating ratings. The semiconductor devices cannot operate normally over the recommended operating ratings, even if when they are used over such ratings by momentary electronic noise or surge. And the semiconductor devices may receive serious damage when they continue to operate over the recommended operating ratings.

ELECTRICAL CHARACTERISTICS

• R1114xxx1A

(Ta=25°C)

Symbol	Item	Conditions	Min.	Typ.	Max.	Unit
V_{OUT}	Output Voltage	$V_{IN} = \text{Set } V_{OUT}+1V$ $1mA \leq I_{OUT} \leq 30mA$	$\times 0.980$		$\times 1.020$	V
I_{OUT}	Output Current	$V_{IN}-V_{OUT} = 1.0V$	150			mA
$\Delta V_{OUT}/\Delta I_{OUT}$	Load Regulation	$V_{IN} = \text{Set } V_{OUT}+1V$ $1mA \leq I_{OUT} \leq 150mA$		22	40	mV
V_{DIF}	Dropout Voltage	$I_{OUT} = 150mA$	Refer to the <i>Product-specific Electrical Characteristics</i>			
I_{SS}	Supply Current	$V_{IN} = \text{Set } V_{OUT}+1V, I_{OUT} = 0mA$		75	95	μA
$I_{standby}$	Supply Current (Standby)	$V_{IN} = \text{Set } V_{OUT}+1V$ $V_{CE} = V_{DD}$		0.1	1.0	μA
$\Delta V_{OUT}/\Delta V_{IN}$	Line Regulation	$V_{OUT} > 1.7V,$ Set $V_{OUT}+0.5V \leq V_{IN} \leq 6.0V$ ($V_{OUT} \leq 1.7V, 2.2V \leq V_{IN} \leq 6.0V$) $I_{OUT} = 30mA$		0.02	0.10	%/V
I_{SC}	Short Current Limit	$V_{OUT} = 0V$		40		mA
R_{PU}	\overline{CE} Pull-up Resistance		0.7	2.0	8.0	$M\Omega$
V_{CEH}	\overline{CE} Input Voltage "H"		1.5		6.0	V
V_{CEL}	\overline{CE} Input Voltage "L"		0.0		0.3	V

R1114N

NO.EC-094-131219

• R1114xxx1B/D

(Ta=25°C)

Symbol	Item	Conditions	Min.	Typ.	Max.	Unit
V_{OUT}	Output Voltage	$V_{IN} = \text{Set } V_{OUT}+1V$ $1mA \leq I_{OUT} \leq 30mA$	$\times 0.980$		$\times 1.020$	V
I_{OUT}	Output Current	$V_{IN}-V_{OUT} = 1.0V$	150			mA
$\Delta V_{OUT}/\Delta I_{OUT}$	Load Regulation	$V_{IN} = \text{Set } V_{OUT}+1V$ $1mA \leq I_{OUT} \leq 150mA$		22	40	mV
V_{DIF}	Dropout Voltage	$I_{OUT} = 150mA$	Refer to the <i>Product-specific Electrical Characteristics</i>			
I_{SS}	Supply Current	$V_{IN} = \text{Set } V_{OUT}+1V, I_{OUT} = 0mA$		75	95	μA
$I_{standby}$	Supply Current (Standby)	$V_{IN} = \text{Set } V_{OUT}+1V$ $V_{CE} = GND$		0.1	1.0	μA
$\Delta V_{OUT}/\Delta V_{IN}$	Line Regulation	$V_{OUT} > 1.7V,$ Set $V_{OUT}+0.5V \leq V_{IN} \leq 6.0V$ ($V_{OUT} \leq 1.7V, 2.2V \leq V_{IN} \leq 6.0V$) $I_{OUT} = 30mA$		0.02	0.10	%/V
I_{SC}	Short Current Limit	$V_{OUT} = 0V$		40		mA
R_{PD}	CE Pull-down Resistance		0.7	2.0	8.0	$M\Omega$
V_{CEH}	CE Input Voltage "H"		1.5		6.0	V
V_{CEL}	CE Input Voltage "L"		0.0		0.3	V
R_{LOW}	On Resistance of Nch for auto-discharge (Only for D version)	$V_{CE} = 0V$		60		Ω

Product-specific Electrical Characteristics

(Ta=25°C)

Product Name	V _{OUT} [V]			V _{DIF} [V]	
	MIN.	TYP.	MAX.	TYP.	MAX.
R1114N151x	1.470	1.500	1.530	0.38	0.70
R1114N161x	1.568	1.600	1.632	0.36	0.65
R1114N171x	1.666	1.700	1.734	0.34	0.60
R1114N181x	1.764	1.800	1.836	0.32	0.55
R1114N181x5	1.813	1.850	1.887		
R1114N191x	1.862	1.900	1.938		
R1114N201x	1.960	2.000	2.040		
R1114N211x	2.058	2.100	2.142	0.28	0.50
R1114N221x	2.156	2.200	2.244		
R1114N231x	2.254	2.300	2.346		
R1114N241x	2.352	2.400	2.448		
R1114N251x	2.450	2.500	2.550		
R1114N261x	2.548	2.600	2.652		
R1114N271x	2.646	2.700	2.754		
R1114N281x	2.744	2.800	2.856	0.22	0.35
R1114N281x5	2.793	2.850	2.907		
R1114N291x	2.842	2.900	2.958		
R1114N301x	2.940	3.000	3.060		
R1114N311x	3.038	3.100	3.162		
R1114N321x	3.136	3.200	3.264		
R1114N331x	3.234	3.300	3.366		
R1114N341x	3.332	3.400	3.468		
R1114N351x	3.430	3.500	3.570		
R1114N361x	3.528	3.600	3.672		
R1114N371x	3.626	3.700	3.774		
R1114N381x	3.724	3.800	3.876		
R1114N391x	3.822	3.900	3.978		
R1114N401x	3.920	4.000	4.080		

TYPICAL APPLICATIONS

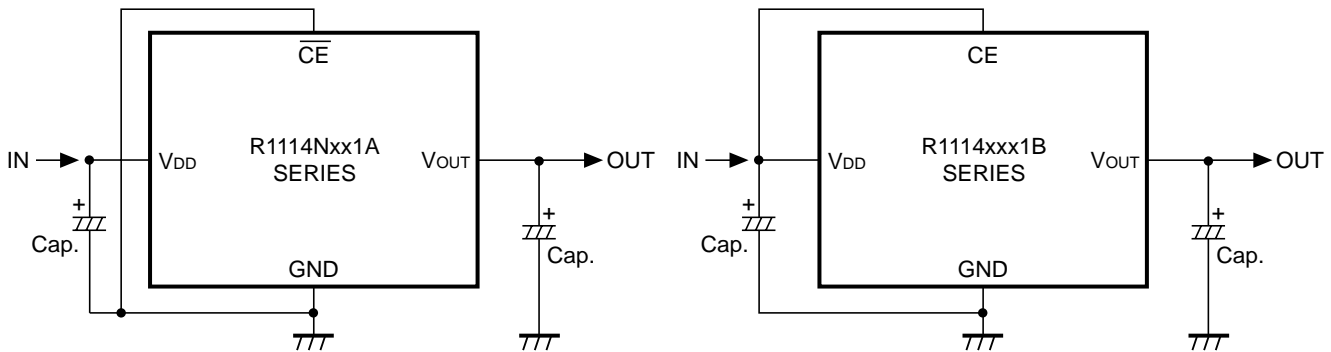

(External Components)

Output Capacitor; Ceramic 0.47 μ F (Set Output Voltage in the range from 2.5 to 4.0V)

Ceramic 1.0 μ F (Set Output Voltage in the range from 1.5 to 2.4V)

Input Capacitor; Ceramic 1.0 μ F

TECHNICAL NOTES

When using these ICs, consider the following points:

Phase Compensation

In these ICs, phase compensation is made for securing stable operation even if the load current is varied. For this purpose, use a capacitor C_{OUT} with good frequency characteristics and ESR (Equivalent Series Resistance).

Recommended C2 Values

Output Voltage	RecommendedC2 values
$V_{OUT} \leq 2.4V$	1.0 μ F or more
$2.5V \leq V_{OUT}$	0.47 μ F or more

When using a tantalum type capacitor and the ESR value of the capacitor is large, the output might be unstable. Evaluate a circuit including consideration of frequency characteristics.

PCB Layout

Make V_{DD} and GND lines sufficient. If their impedance is high, noise pickup or unstable operation may result. Connect a capacitor with a capacitance value as much as 1.0 μ F or more between V_{DD} and GND pin, and as close as possible to the pins.

Set external components, especially the output capacitor, as close as possible to the ICs, and make wiring as short as possible.

TYPICAL APPLICATION FOR IC CHIP BREAKDOWN PREVENTION

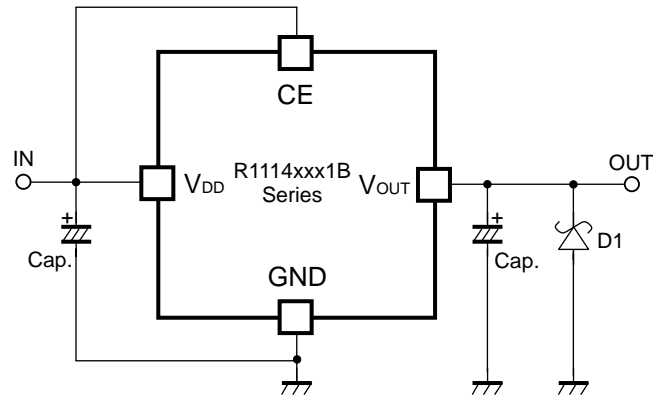

(External Components)

Output Capacitor; Ceramic 0.47 μ F (Set Output Voltage in the range from 2.5 to 4.0V)

Ceramic 1.0 μ F (Set Output Voltage in the range from 1.5 to 2.4V)

Input Capacitor; Ceramic 1.0 μ F

When a sudden surge of electrical current travels along the V_{OUT} pin and GND due to a short-circuit, electrical resonance of a circuit involving an output capacitor and a short circuit inductor generates a negative voltage and may damage the device or the load devices. Connecting a schottky diode (D1) between the V_{OUT} pin and GND has the effect of preventing damage to them.

PACKAGE INFORMATION

POWER DISSIPATION (SOT-23-5)

Power Dissipation (P_D) depends on conditions of mounting on board. This specification is based on the measurement at the condition below:

(Power Dissipation (SOT-23-5) is substitution of SOT-23-6.)

* Measurement Conditions

	Standard Test Land Pattern
Environment	Mounting on Board (Wind velocity=0m/s)
Board Material	Glass cloth epoxy plastic (Double sided)
Board Dimensions	40mm x 40mm x 1.6mm
Copper Ratio	Top side: Approx. 50%, Back side: Approx. 50%
Through-holes	ϕ 0.5mm x 44pcs

* Measurement Result:

($T_a=25^\circ\text{C}$, $T_{j\text{max}}=125^\circ\text{C}$)

	Standard Land Pattern	Free Air
Power Dissipation	420mW	250mW
Thermal Resistance	$\theta_{ja} = (125-25^\circ\text{C})/0.42\text{W} = 238^\circ\text{C/W}$	400 $^\circ\text{C/W}$

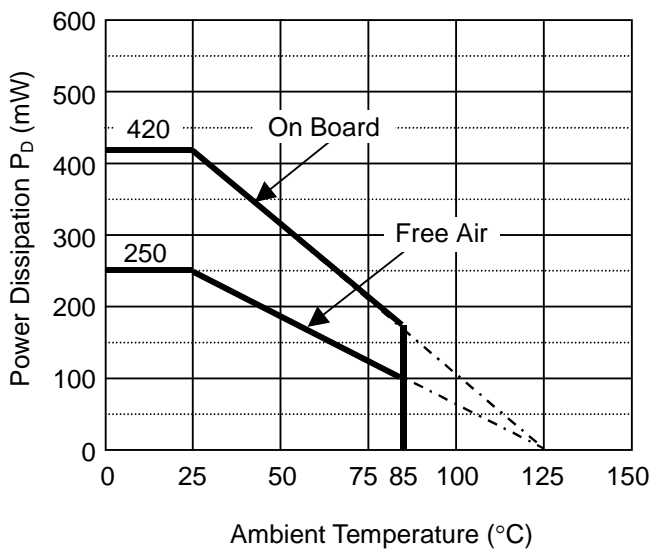

Power Dissipation

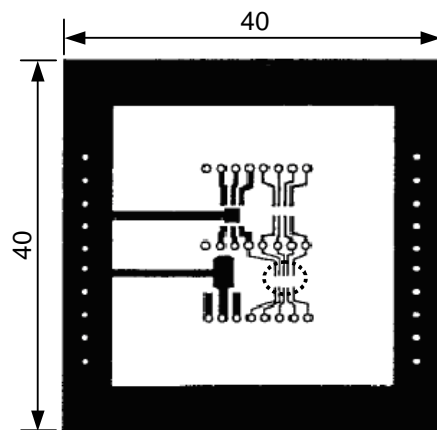

Measurement Board Pattern

 IC Mount Area (Unit: mm)

PACKAGE DIMENSIONS (SOT-23-5)

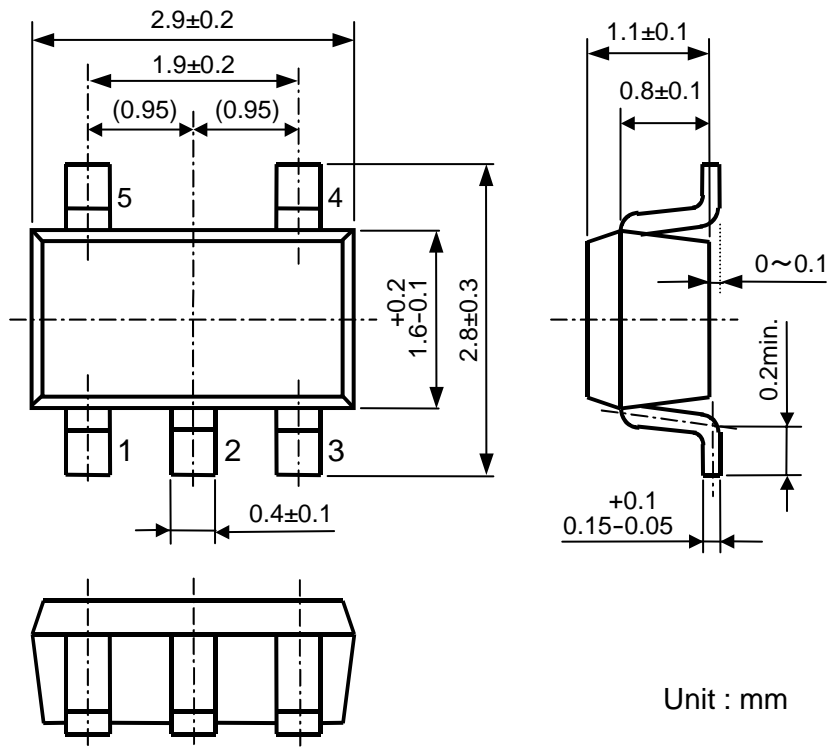

SOT-23-5 Package Dimensions

MARK SPECIFICATION (SOT-23-5)

①②③: Product Code ... Refer to MARK SPECIFICATION TABLE (SOT-23-5)

④⑤: Lot Number ... Alphanumeric Serial Number

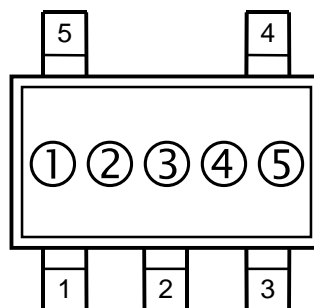

SOT-23-5 Mark Specification

R1114N

NO.EC-094-131219

MARK SPECIFICATION TABLE (SOT-23-5)

R1114Nxx1A				R1114Nxx1B				R1114Nxx1D						
Product Name	①	②	③	V_{SET}	Product Name	①	②	③	V_{SET}	Product Name	①	②	③	V_{SET}
R1114N151A	4	1	5	1.5 V	R1114N151B	5	1	5	1.5 V	R1114N151D	6	1	5	1.5 V
R1114N161A	4	1	6	1.6 V	R1114N161B	5	1	6	1.6 V	R1114N161D	6	1	6	1.6 V
R1114N171A	4	1	7	1.7 V	R1114N171B	5	1	7	1.7 V	R1114N171D	6	1	7	1.7 V
R1114N181A	4	1	8	1.8 V	R1114N181B	5	1	8	1.8 V	R1114N181D	6	1	8	1.8 V
R1114N191A	4	1	9	1.9 V	R1114N191B	5	1	9	1.9 V	R1114N191D	6	1	9	1.9 V
R1114N201A	4	2	0	2.0 V	R1114N201B	5	2	0	2.0 V	R1114N201D	6	2	0	2.0 V
R1114N211A	4	2	1	2.1 V	R1114N211B	5	2	1	2.1 V	R1114N211D	6	2	1	2.1 V
R1114N221A	4	2	2	2.2 V	R1114N221B	5	2	2	2.2 V	R1114N221D	6	2	2	2.2 V
R1114N231A	4	2	3	2.3 V	R1114N231B	5	2	3	2.3 V	R1114N231D	6	2	3	2.3 V
R1114N241A	4	2	4	2.4 V	R1114N241B	5	2	4	2.4 V	R1114N241D	6	2	4	2.4 V
R1114N251A	4	2	5	2.5 V	R1114N251B	5	2	5	2.5 V	R1114N251D	6	2	5	2.5 V
R1114N261A	4	2	6	2.6 V	R1114N261B	5	2	6	2.6 V	R1114N261D	6	2	6	2.6 V
R1114N271A	4	2	7	2.7 V	R1114N271B	5	2	7	2.7 V	R1114N271D	6	2	7	2.7 V
R1114N281A	4	2	8	2.8 V	R1114N281B	5	2	8	2.8 V	R1114N281D	6	2	8	2.8 V
R1114N291A	4	2	9	2.9 V	R1114N291B	5	2	9	2.9 V	R1114N291D	6	2	9	2.9 V
R1114N301A	4	3	0	3.0 V	R1114N301B	5	3	0	3.0 V	R1114N301D	6	3	0	3.0 V
R1114N311A	4	3	1	3.1 V	R1114N311B	5	3	1	3.1 V	R1114N311D	6	3	1	3.1 V
R1114N321A	4	3	2	3.2 V	R1114N321B	5	3	2	3.2 V	R1114N321D	6	3	2	3.2 V
R1114N331A	4	3	3	3.3 V	R1114N331B	5	3	3	3.3 V	R1114N331D	6	3	3	3.3 V
R1114N341A	4	3	4	3.4 V	R1114N341B	5	3	4	3.4 V	R1114N341D	6	3	4	3.4 V
R1114N351A	4	3	5	3.5 V	R1114N351B	5	3	5	3.5 V	R1114N351D	6	3	5	3.5 V
R1114N361A	4	3	6	3.6 V	R1114N361B	5	3	6	3.6 V	R1114N361D	6	3	6	3.6 V
R1114N371A	4	3	7	3.7 V	R1114N371B	5	3	7	3.7 V	R1114N371D	6	3	7	3.7 V
R1114N381A	4	3	8	3.8 V	R1114N381B	5	3	8	3.8 V	R1114N381D	6	3	8	3.8 V
R1114N391A	4	3	9	3.9 V	R1114N391B	5	3	9	3.9 V	R1114N391D	6	3	9	3.9 V
R1114N401A	4	4	0	4.0 V	R1114N401B	5	4	0	4.0 V	R1114N401D	6	4	0	4.0 V
R1114N281A5	4	4	1	2.85 V	R1114N281B5	5	4	1	2.85 V	R1114N281D5	6	4	1	2.85 V
R1114N181A5	4	4	2	1.85 V	R1114N181B5	5	4	2	1.85 V	R1114N181D5	6	4	2	1.85 V

TEST CIRCUITS

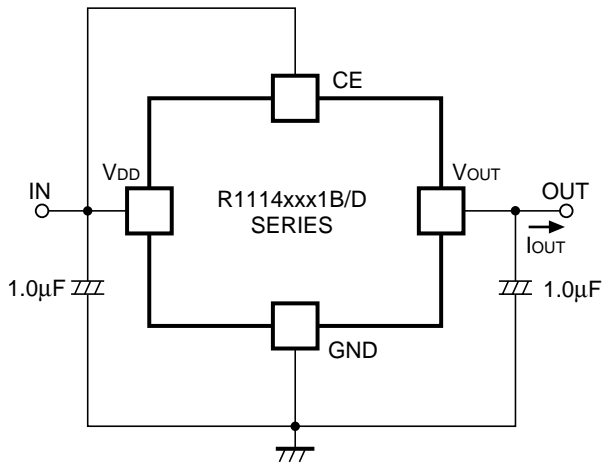

Standard test Circuit

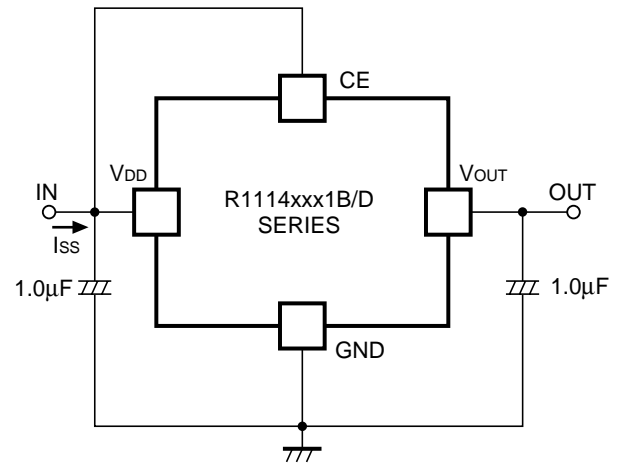

Supply Current Test Circuit

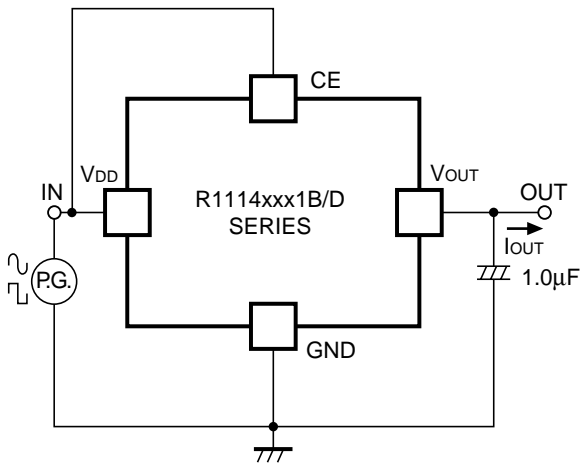

Ripple Rejection, Line Transient Response Test Circuit

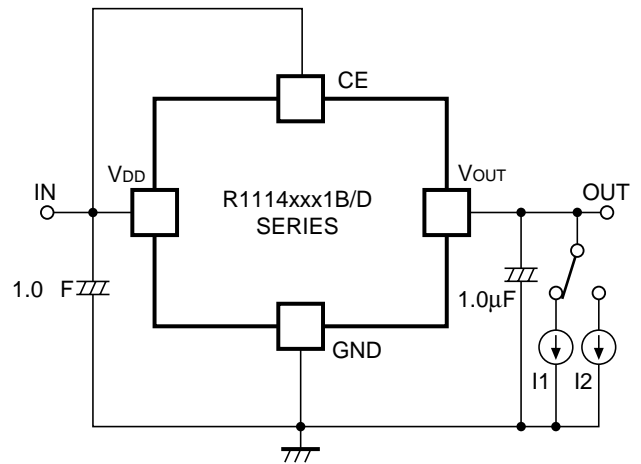

Load Transient Response Test Circuit

TYPICAL CHARACTERISTICS

Note: Typical Characteristics are intended to be used as reference data; they are not guaranteed.

1) Output Voltage vs. Output Current (Ta=25°C)

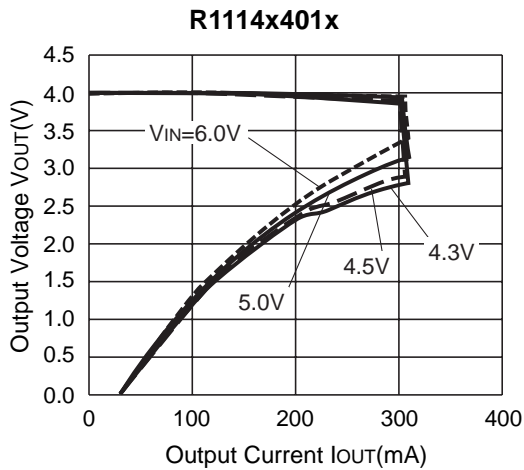
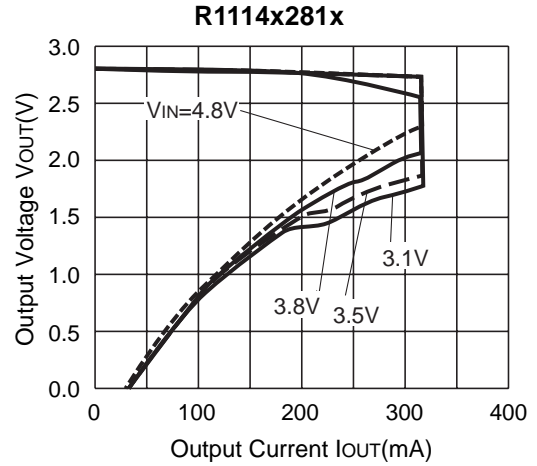
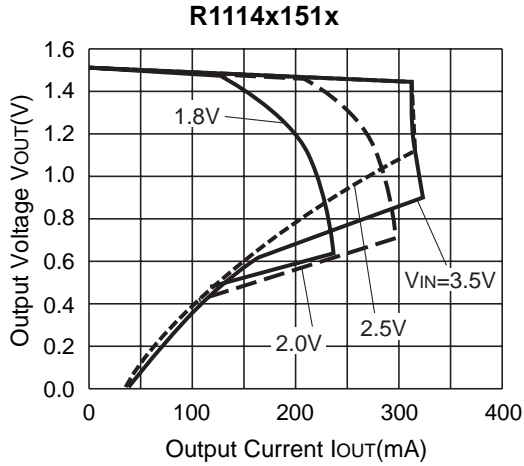

2) Output Voltage vs. Input Voltage (Ta=25°C)

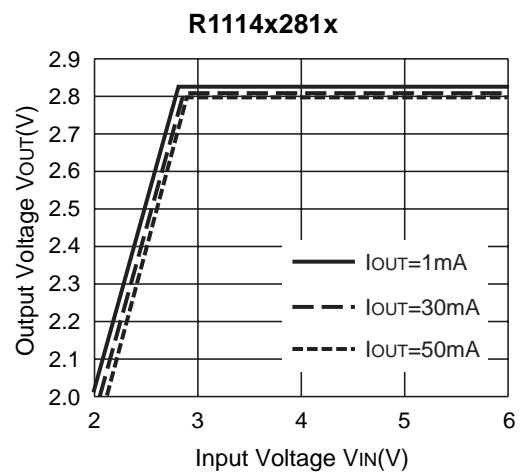
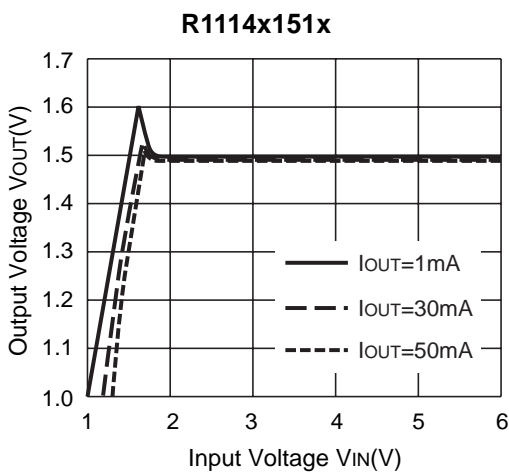

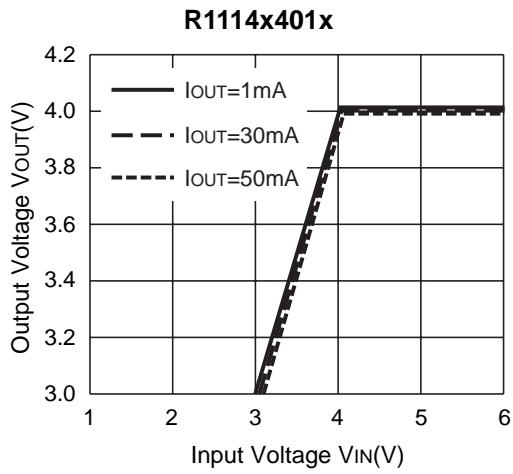

3) Supply Current vs. Input Voltage ($T_a=25^\circ C$)

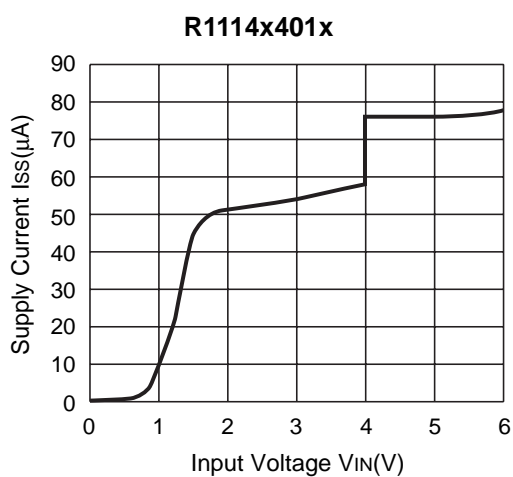
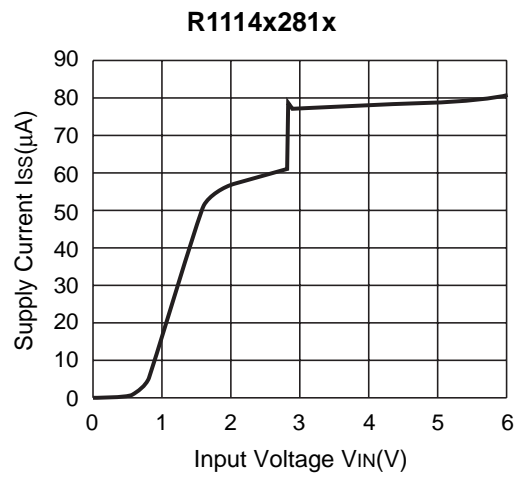
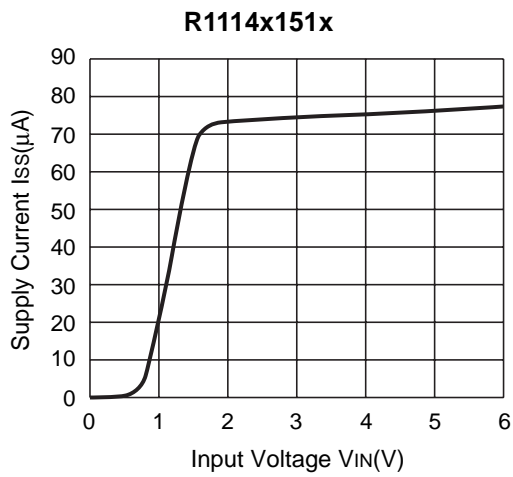

R1114NNO.EC-094-131219

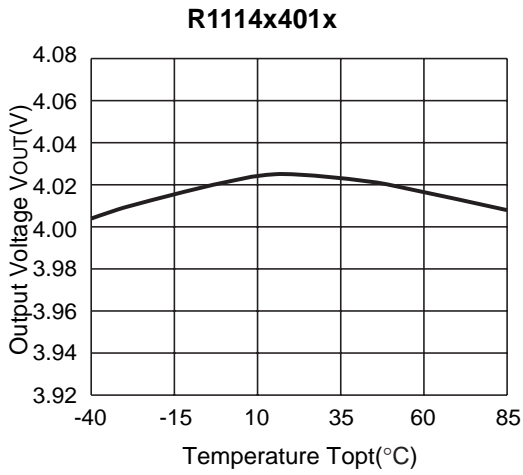
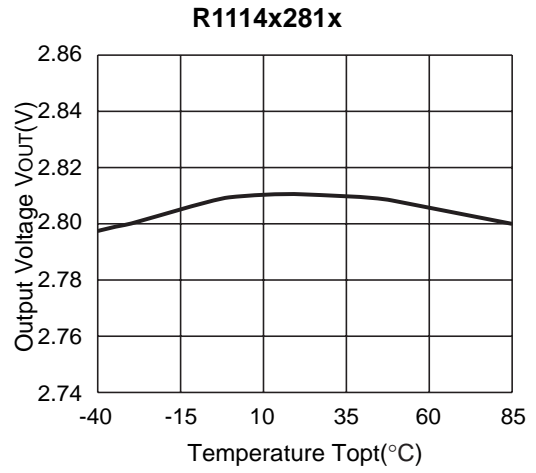
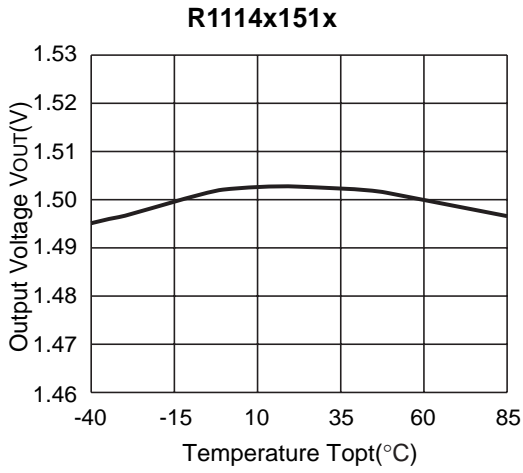
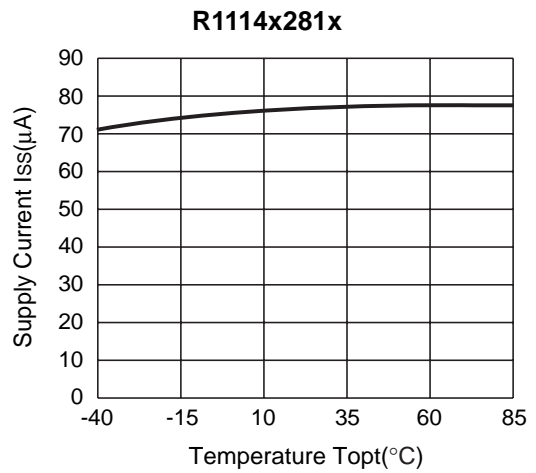
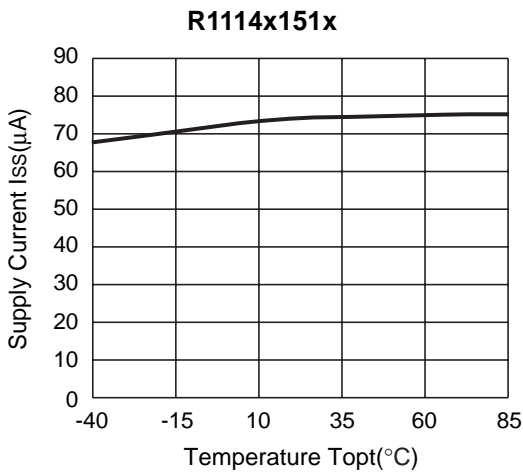
4) Output Voltage vs. Temperature**5) Supply Current vs. Temperature**

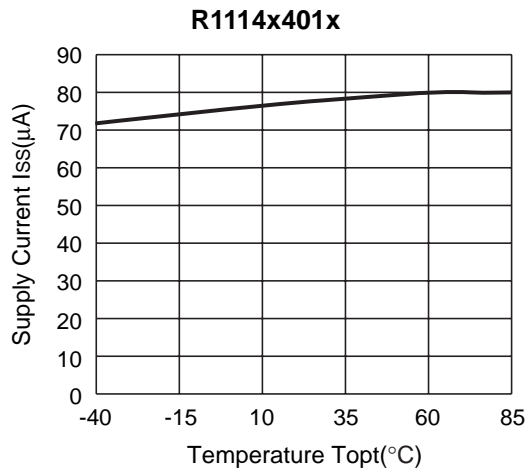

6) Dropout Voltage vs. Temperature

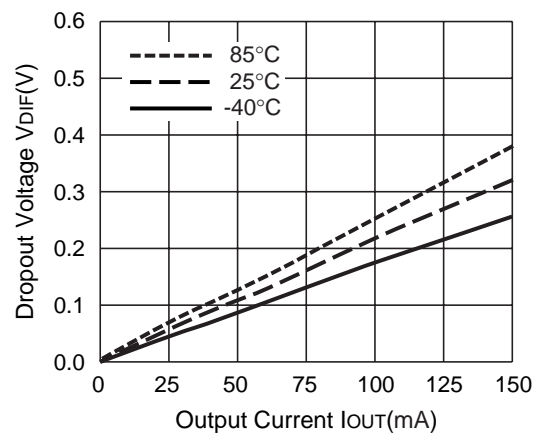
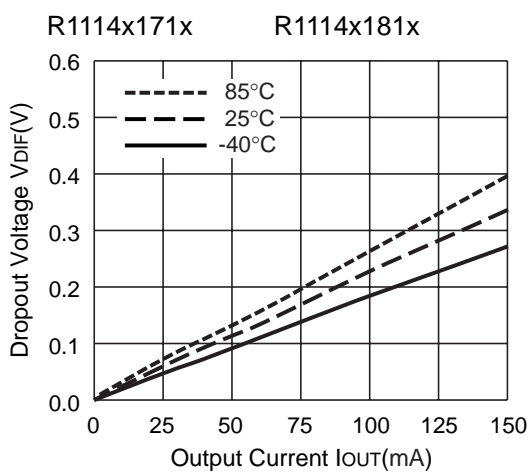
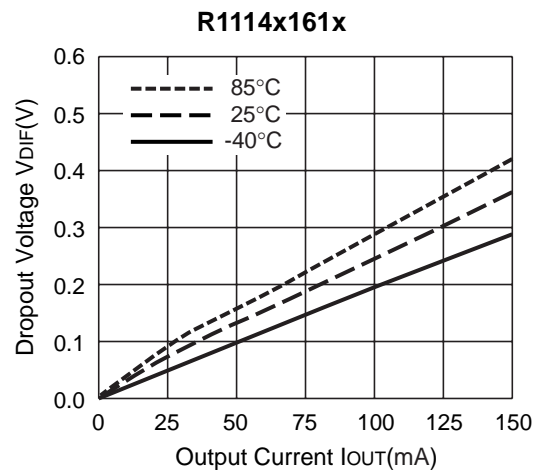
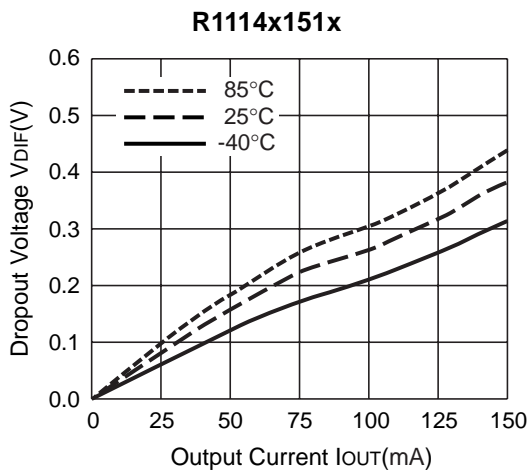

R1114N

NO.EC-094-131219

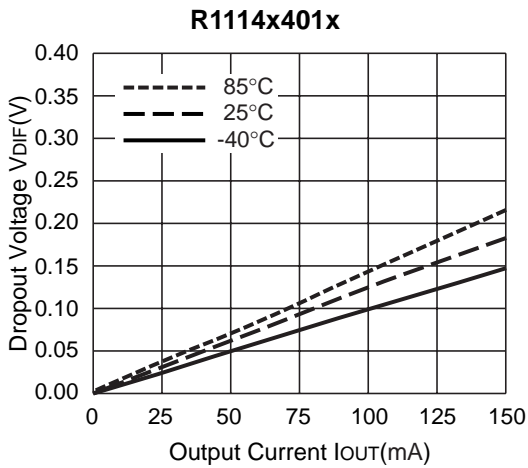
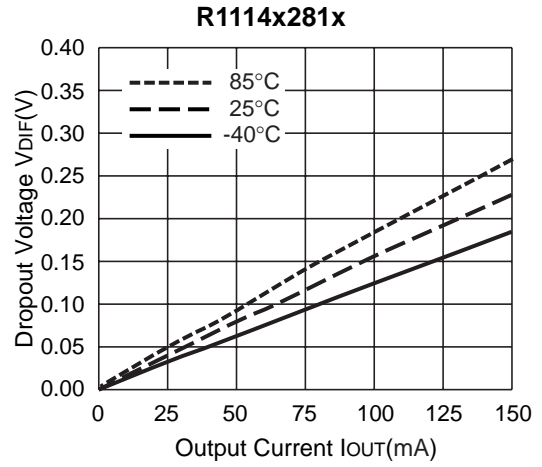
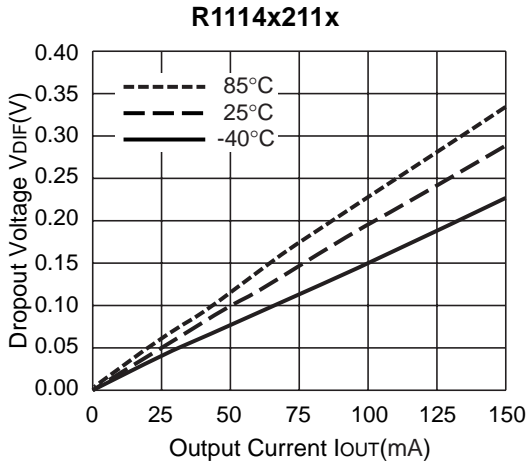

7) Dropout Voltage vs. Set Output Voltage ($T_a=25^\circ\text{C}$)

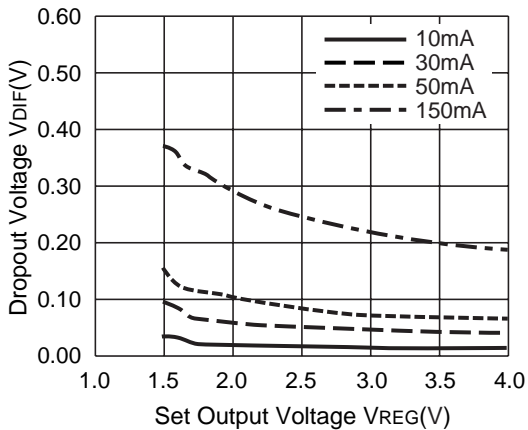

8) Ripple Rejection vs. Input Bias Voltage ($T_a=25^\circ\text{C}$, $C_{IN}=\text{none}$, $C_{OUT}=\text{ceramic } 0.47\mu\text{F}$)

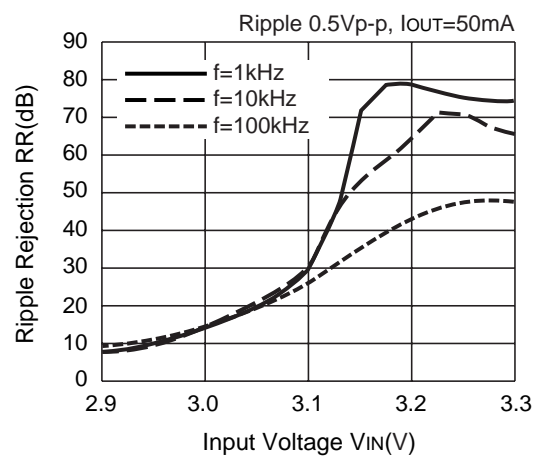
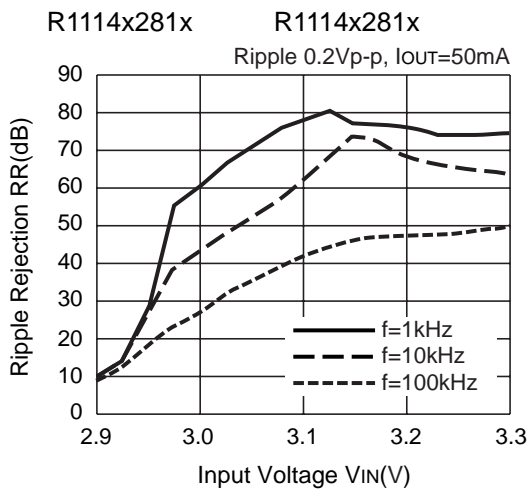
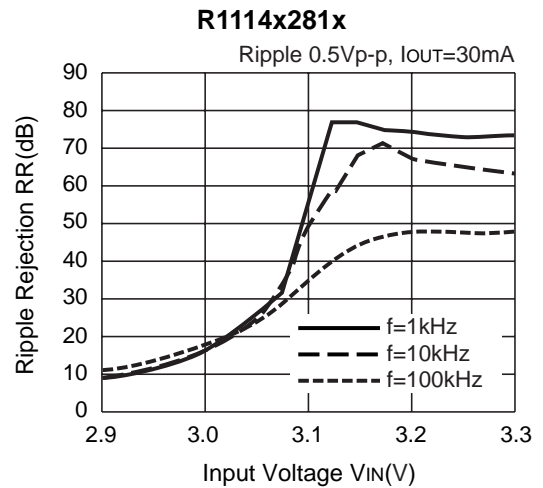
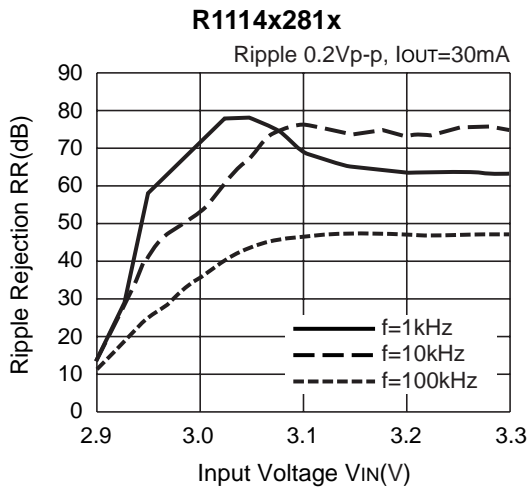
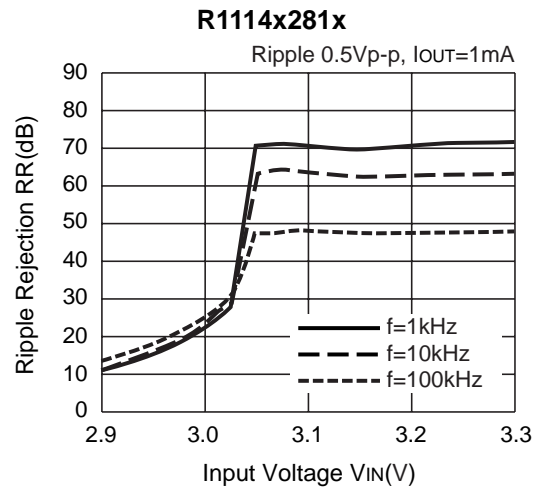
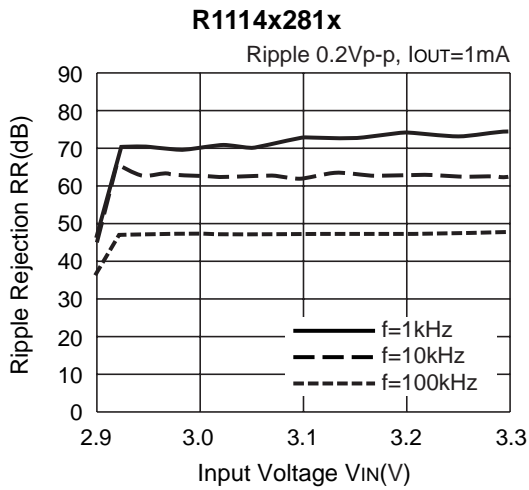

R1114N

NO.EC-094-131219

9) Ripple Rejection vs. Frequency (C_{IN}=none)

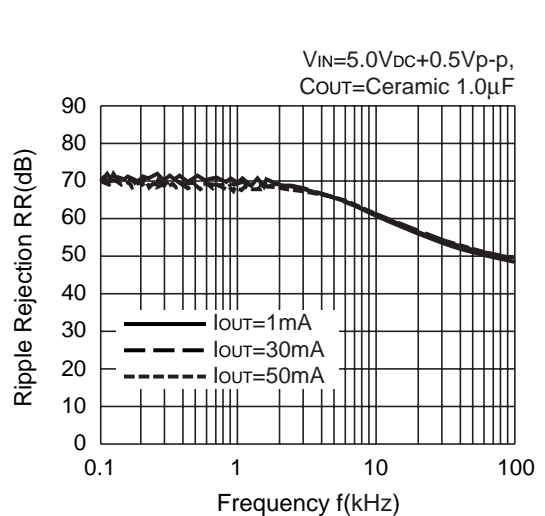
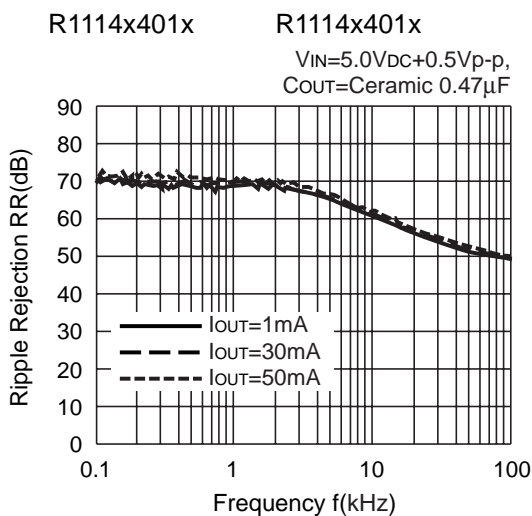
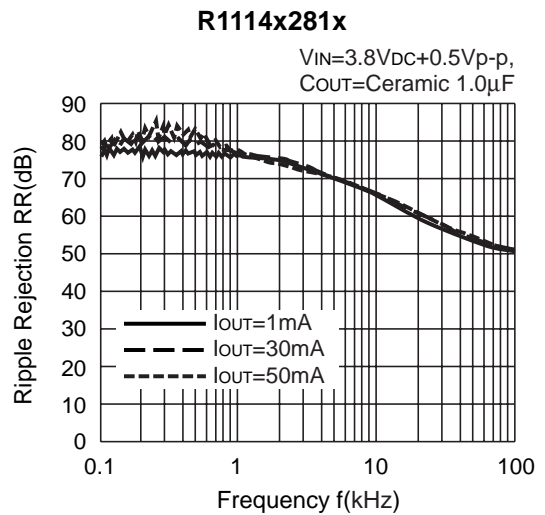
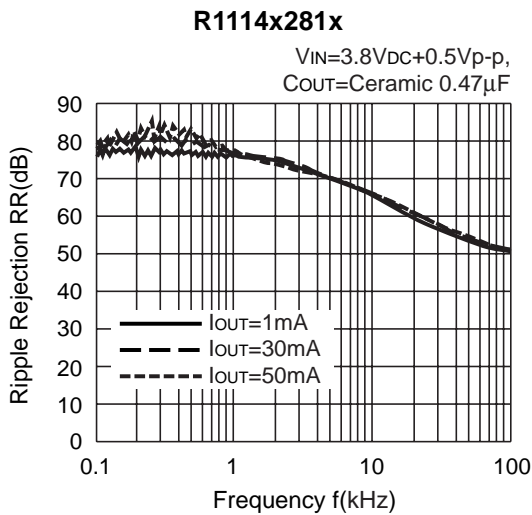
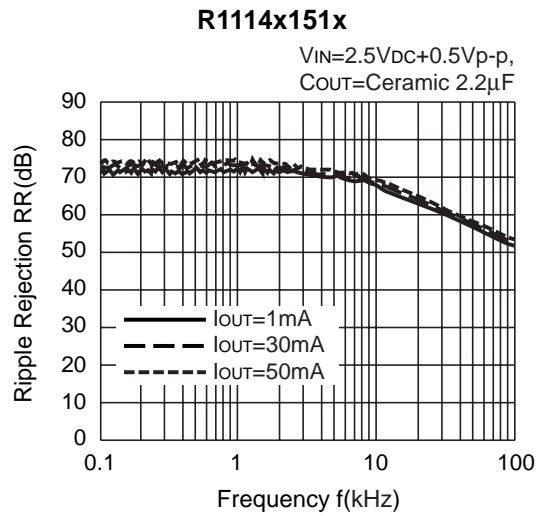
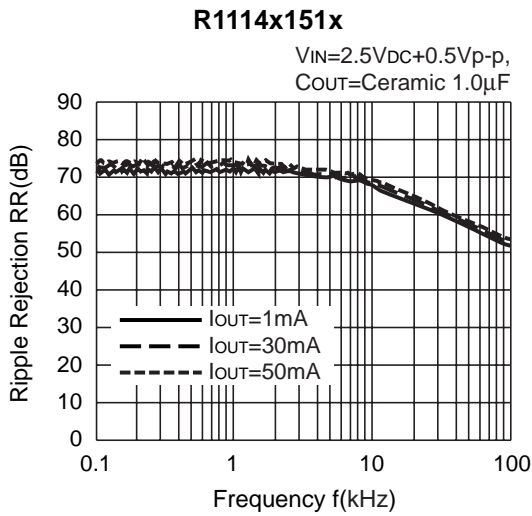

10) Input Transient Response ($I_{OUT}=30mA$, $C_{IN}=none$, $t_r=t_f=5\mu s$, $C_{OUT}=Ceramic\ 0.47\mu F$)

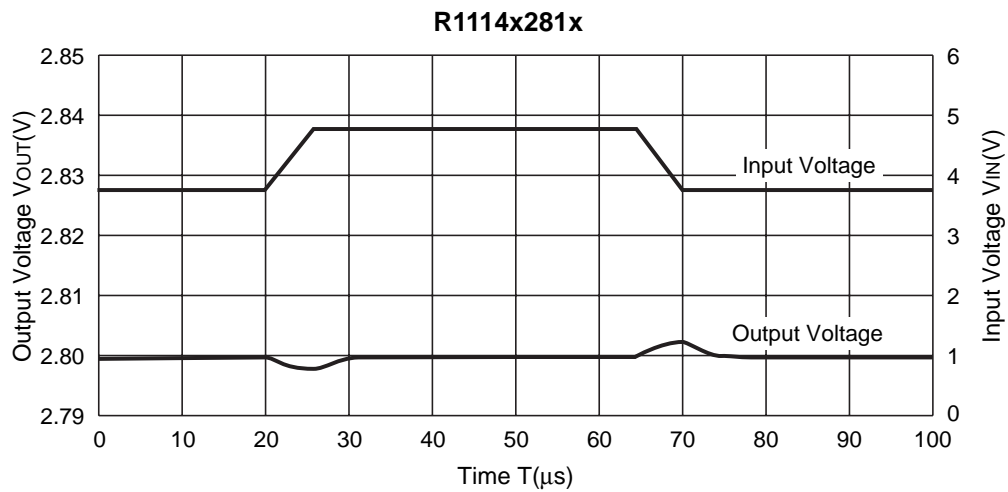
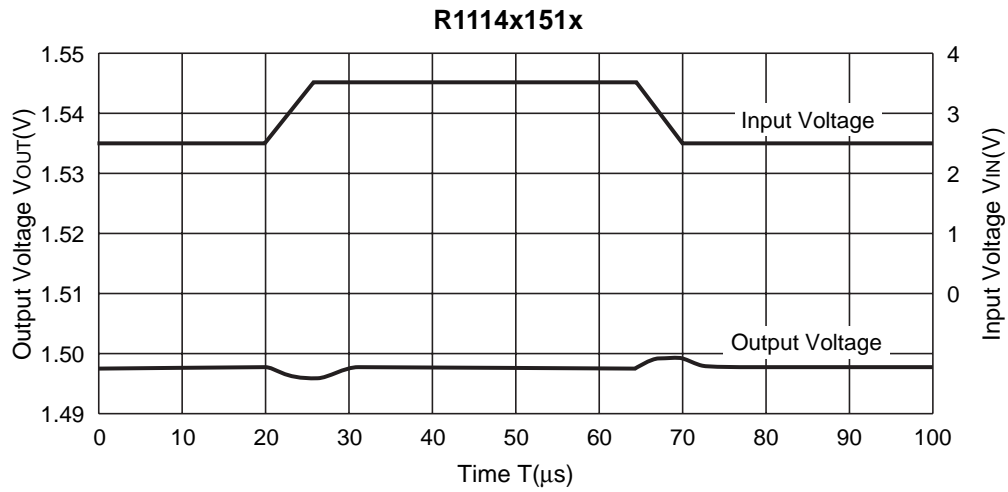

11) Load Transient Response ($t_r=t_f=0.5\mu s$, $C_{IN}=Ceramic\ 1.0\mu F$)

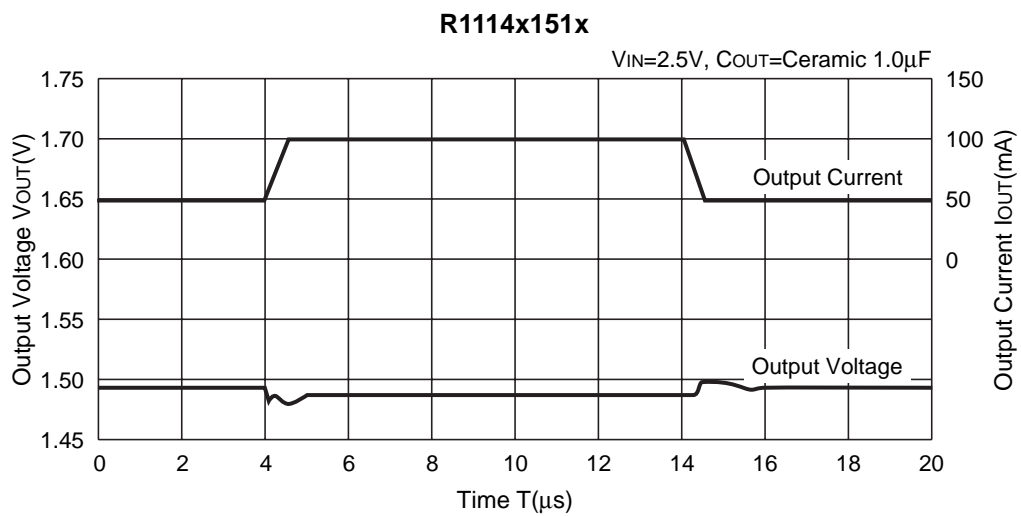

R1114x151x

V_{IN}=2.5V, C_{OUT}=Ceramic 2.2μF

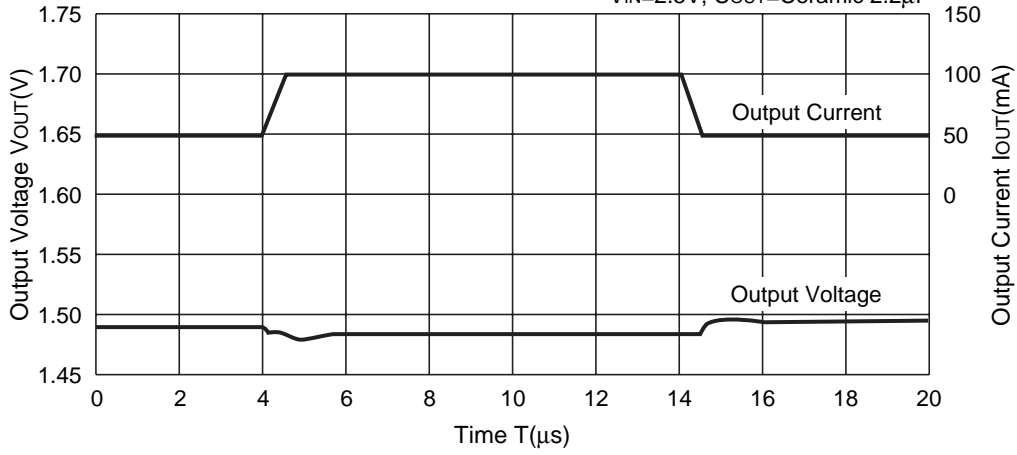

R1114x281x

V_{IN}=3.8V, C_{OUT}=Ceramic 0.47μF

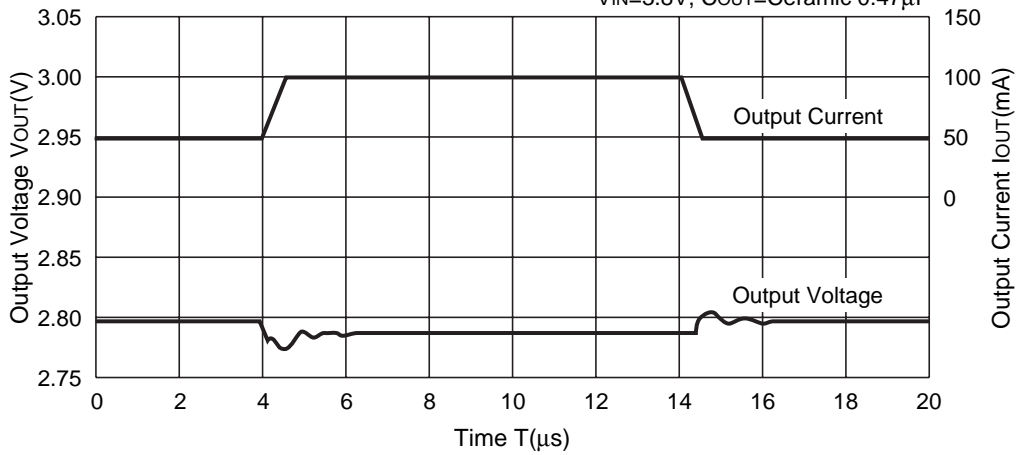

R1114x281x

V_{IN}=3.8V, C_{OUT}=Ceramic 1.0μF

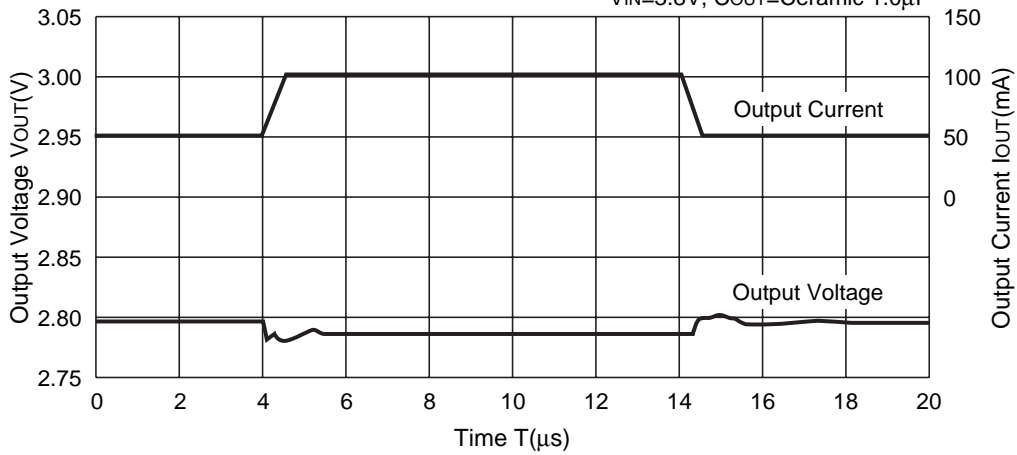

R1114x281x

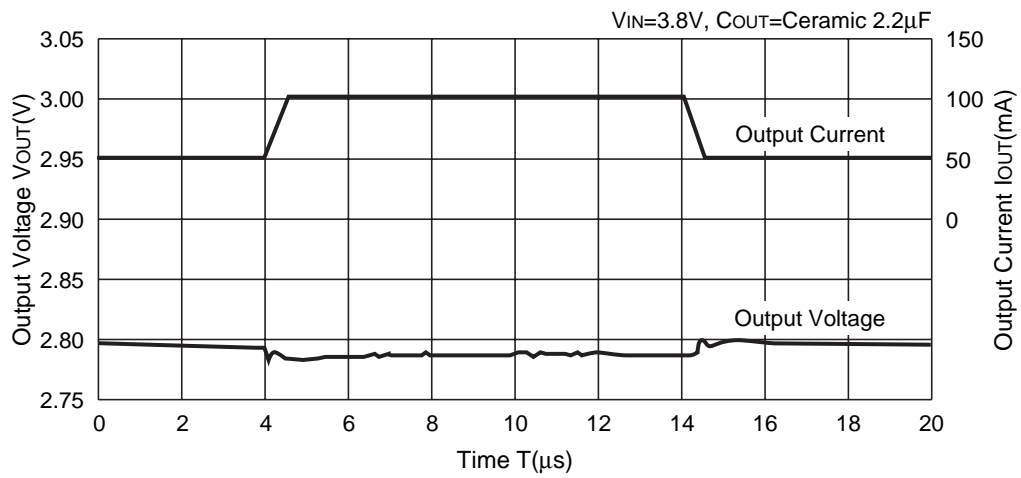

12) Turn-on/off speed with CE pin (D version)

R1114x151D ($V_{IN}=2.5V, C_{IN}=\text{Ceramic } 1.0\mu F, C_{OUT}=\text{Ceramic } 1.0\mu F$)

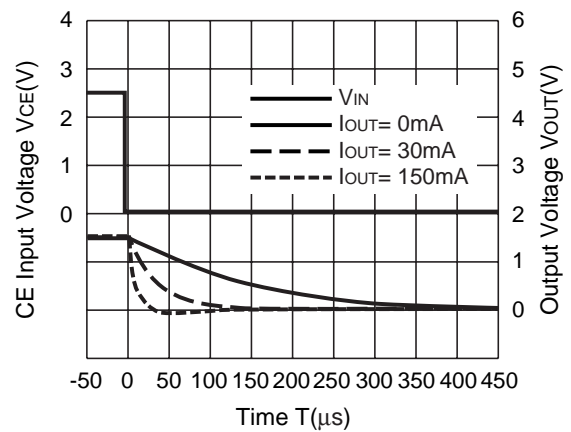
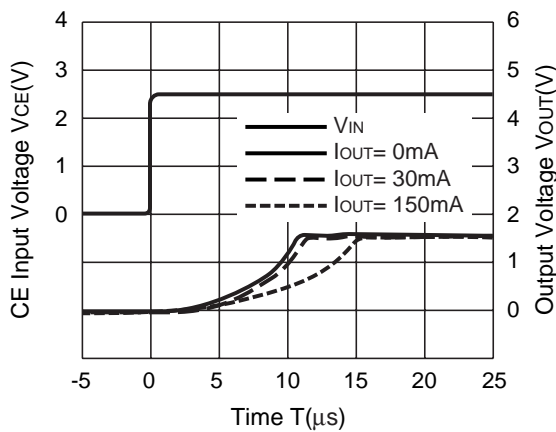

R1114x281D ($V_{IN}=3.8V, C_{IN}=\text{Ceramic } 0.47\mu F, C_{OUT}=\text{Ceramic } 0.47\mu F$)

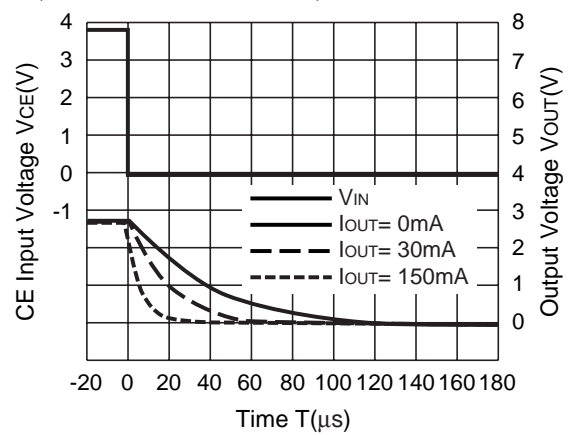
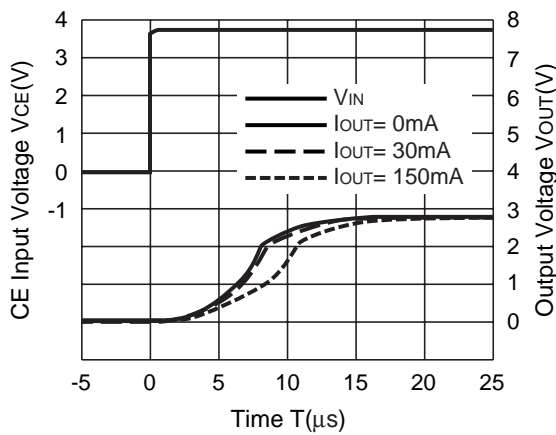

R1114x401D ($V_{IN}=5.0V$, $C_{IN}=\text{Ceramic } 0.47\mu F$, $C_{OUT}=\text{Ceramic } 0.47\mu F$)

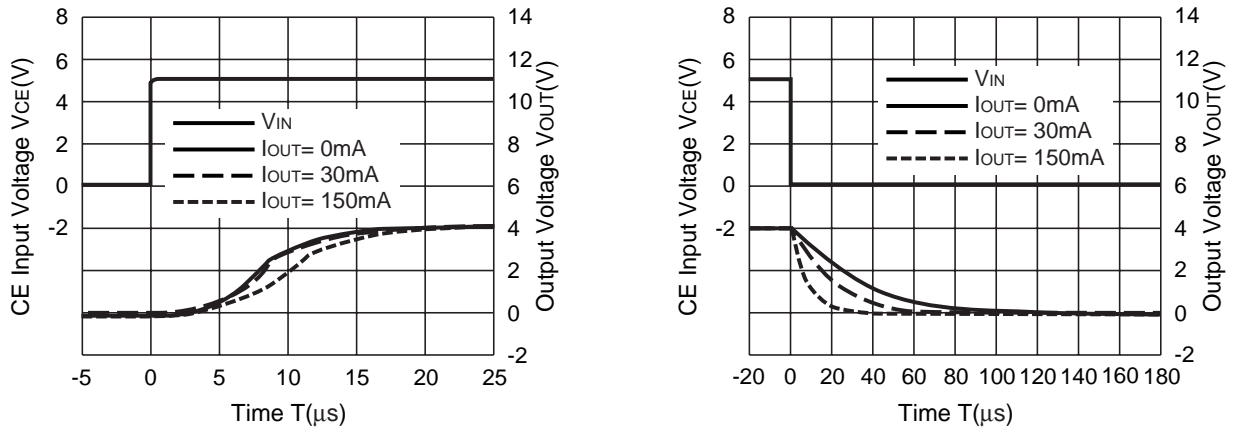

ESR vs. Output Current

When using these ICs, consider the following points:

In these ICs, phase compensation is made for securing stable operation even if the load current is varied. For this purpose, use a capacitor C_{OUT} with good frequency characteristics and ESR (Equivalent Series Resistance) of which is in the range described as follows:

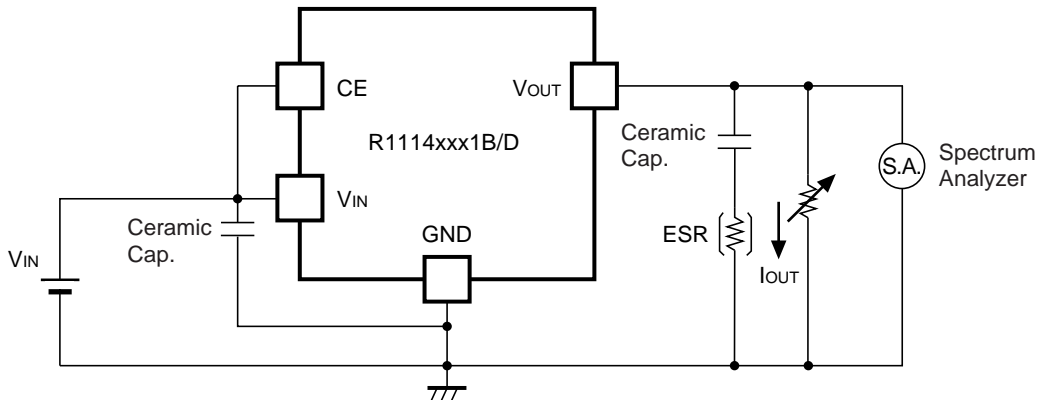

Measuring Circuit for white noise; R1114xxx1B/D

The relations between I_{OUT} (Output Current) and ESR of an output capacitor are shown below. The conditions when the white noise level is under $40\mu V$ (Avg.) are marked as the hatched area in the graph.

(Note: If additional ceramic capacitors are connected to the Output Pin with Output capacitor for phase compensation, the operation might be unstable. Because of this, test these ICs with as same external components as ones to be used on the PCB.)

<Measurement conditions>

- (1) $V_{IN}=V_{OUT}+1V$
- (2) Frequency Band: 10Hz to 2MHz
- (3) Temperature: $-40^{\circ}C$ to $25^{\circ}C$

R1114x151x

C_{IN}=Ceramic 1.0 μ F,
C_{OUT}=Ceramic 1.0 μ F

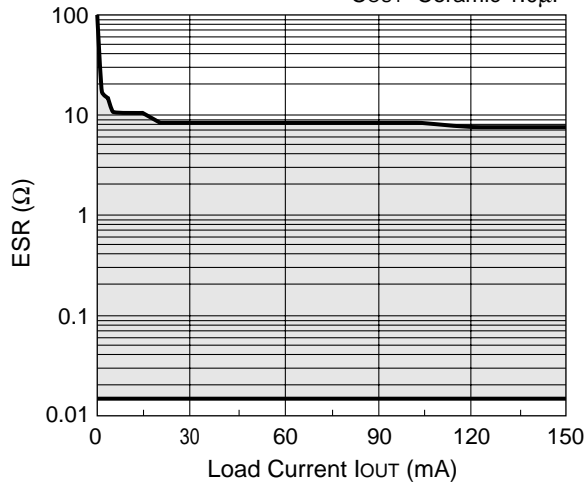

R1114x161x

C_{IN}=Ceramic 0.47 μ F,
C_{OUT}=Ceramic 0.68 μ F

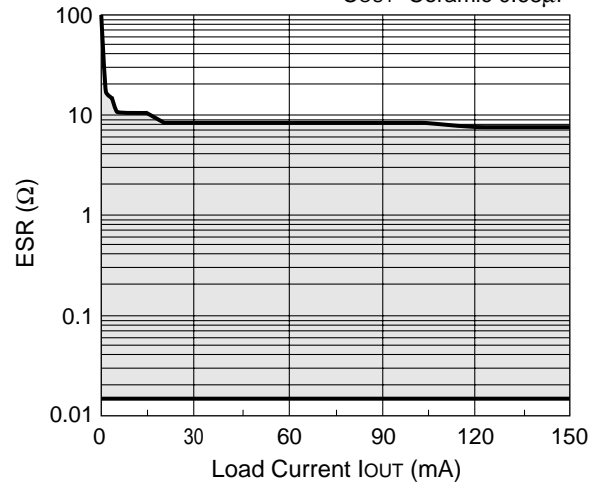

R1114x211x

C_{IN}=Ceramic 0.47 μ F,
C_{OUT}=Ceramic 0.47 μ F

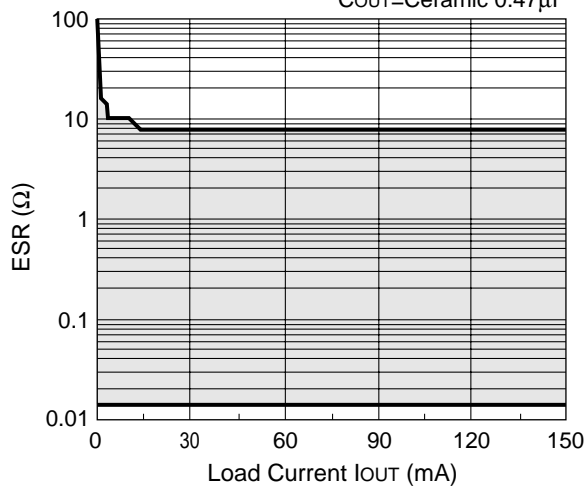

R1114x281x

C_{IN}=Ceramic 0.47 μ F,
C_{OUT}=Ceramic 0.47 μ F

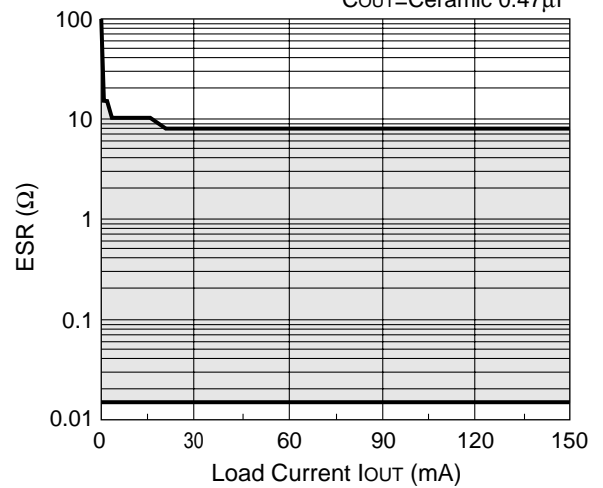



1. The products and the product specifications described in this document are subject to change or discontinuation of production without notice for reasons such as improvement. Therefore, before deciding to use the products, please refer to our sales representatives for the latest information thereon.
2. The materials in this document may not be copied or otherwise reproduced in whole or in part without prior written consent of our company.
3. Please be sure to take any necessary formalities under relevant laws or regulations before exporting or otherwise taking out of your country the products or the technical information described herein.
4. The technical information described in this document shows typical characteristics of and example application circuits for the products. The release of such information is not to be construed as a warranty of or a grant of license under our company's or any third party's intellectual property rights or any other rights.
5. The products in this document are designed for automotive applications. However, when using the products for automotive applications, please make sure to contact our sales representative in advance due to confirming the quality level.
6. We are making our continuous effort to improve the quality and reliability of our products, but semiconductor products are likely to fail with certain probability. In order to prevent any injury to persons or damages to property resulting from such failure, customers should be careful enough to incorporate safety measures in their design, such as redundancy feature, fire containment feature and fail-safe feature. We do not assume any liability or responsibility for any loss or damage arising from misuse or inappropriate use of the products.
7. Anti-radiation design is not implemented in the products described in this document.
8. The X-ray exposure can influence functions and characteristics of the products. Confirm the product functions and characteristics in the evaluation stage.
9. WLCSP products should be used in light shielded environments. The light exposure can influence functions and characteristics of the products under operation or storage.
10. There can be variation in the marking when different AOI (Automated Optical Inspection) equipment is used. In the case of recognizing the marking characteristic with AOI, please contact our sales or our distributor before attempting to use AOI.
11. Please contact our sales representatives should you have any questions or comments concerning the products or the technical information.



Nisshinbo Micro Devices Inc.

Official website

<https://www.nisshinbo-microdevices.co.jp/en/>

Purchase information

<https://www.nisshinbo-microdevices.co.jp/en/buy/>

