



MLVS1812AAM Series

Data Sheet

Product Name	MLVS1812AAM Series
Series	Multilayer Varistor
Size	EIA1812
Version	A0

1. Scope

- (1) SMD type zinc oxide based ceramic chip
- (2) RoHS compliant
- (3) Qualified based on AEC-Q200
- (4) Meet IEC61000-4-5 standard
- (5) Insulator over coat keeps excellent low and stable leakage current
- (6) Quick response time (<1ns)
- (7) High reliability
- (8) High transient current capability
- (9) Compact size for EIA1812
- (10) Moisture Sensitivity Level : Level 1

Applications

Protection against automotive related transient overvoltage

2. Explanation of Part Number

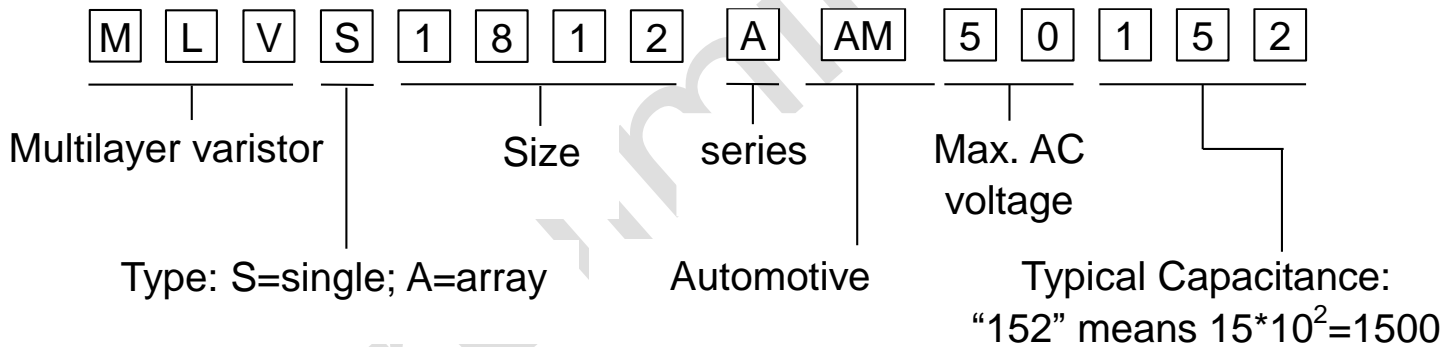

3. Construction & Dimension

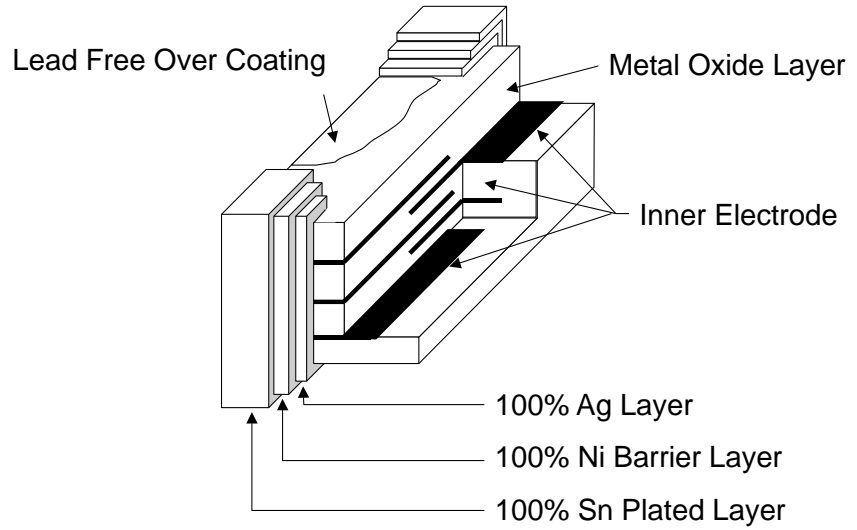
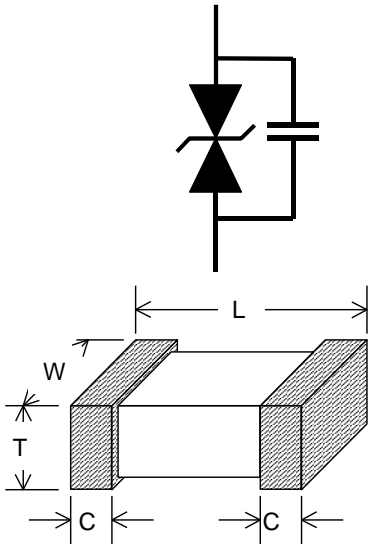

Unit: mm	1812
L	4.5±0.40
W	3.2±0.30
T	2.5 max.
C	0.60±0.3

4. Part ratings and characteristics

4.1. Ratings (25°C for characteristics)

Symbol	Working voltage		Varistor voltage	Clamping Voltage	Capacitance	Peak current
	V_{RMS}	V_{DC}	V_V	V_c	C_p	i_{max}^*
Units	Volts	Volts	Volts	Volts	pF	Amps
	(Max.)	(Max.)		(Max.)	(Typical)	(Max.)
Test Condition			1mA DC	5A 8/20s	1KHz	8/20s
MLVS1812AAM10842	10	14	16~22	42	8400	800
MLVS1812AAM18322	18	26	31~38	62	3200	800
MLVS1812AAM21392	21	30	37~46	70	3950	800
MLVS1812AAM30252	30	38	46~54	80	2500	800
MLVS1812AAM35182	35	45	50~62	90	1800	500
MLVS1812AAM40182	40	56	67~84	135	1800	800
MLVS1812AAM50152	50	65	73~91	140	1500	800
MLVS1812AAM60112	60	85	90~110	145	1100	400
MLVS1812AAM75701	75	100	108~132	200	700	500

V_V – Voltage across the device measured at 1mA DC current.

Equivlent to V_b , “Breakdown Voltage”.

V_c – Maximum peak voltage across the varistor measured at 8/20us waveform and 5A pulse current

C_p – Device capacitance measured with zero volt bias 1Vrms.

i_{max} – Maximum peak current which may be applied with 8/20us waveform without device failure.

5. General electrical specifications

5.1. General technical data

Operating temperature	-40 ... +125°C
Storage temperature (on board)	-40 ... +125°C
Response time	<1 ns
Solderability	245±5°C, 5 +0/-0.5sec
Solder leach resistance	260±5°C, 10 ±1sec

5.2. Taping Package Storage Condition

Storage Time: 12 months max.

Storage Temperature: 5 to 40°C

Relative Humidity: 65% max.

6. Precautions for Handling

6.1. Solder cream in reflow soldering

Refer to the recommendable land pattern as printing mask pattern for solder cream.

(1) Print solder in a thickness of 150 to 200 μm

Dimensions: millimeters (inches)

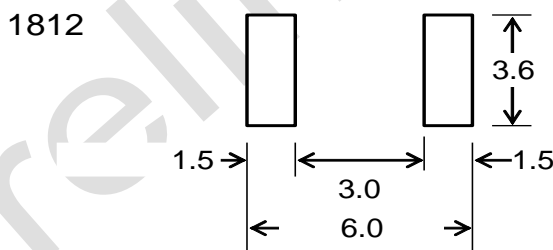

6.2. Precaution for handling of substrate

Do not exceed to bend the board after soldering this product extremely.

(Reference examples)

- Mounting place must be as far as possible from the position, which is close to the break line of board, or on the line of large holes of board.
- Do not bend extremely the board, in mounting another component.
If necessary, use back-up pin (support pin) to prevent from bending extremely.
- Do not break the board by hand. We recommend using the machine or the jig to break it.

6.3. Precaution for soldering

Note that rapid heating, rapid cooling or local heating will easily damage the component.

Do not give heat shock over 100°C in the process of soldering. We recommend taking preheating and gradual cooling.

6.4. Recommendable reflow soldering

Profile Feature	Pb-Free Assembly
Average Ramp-Up Rate (T _{smax} to T _p)	3°C/second max.
Preheat – Temperature Min (T _{smin}) – Temperature Max (T _{smax}) – Time (t _{smin} to t _{smax})	150°C 200°C 60-180 seconds
Time maintained above: – Temperature (T _L) – Time (t _L)	217°C 60-150 seconds
Peak/Classification Temperature (T _p)	260°C
Time within 5 °C of actual Peak Temperature (t _p)	20-40 seconds
Ramp-Down Rate	6°C/second max.
Time 25 °C to Peak Temperature	8 minutes max.

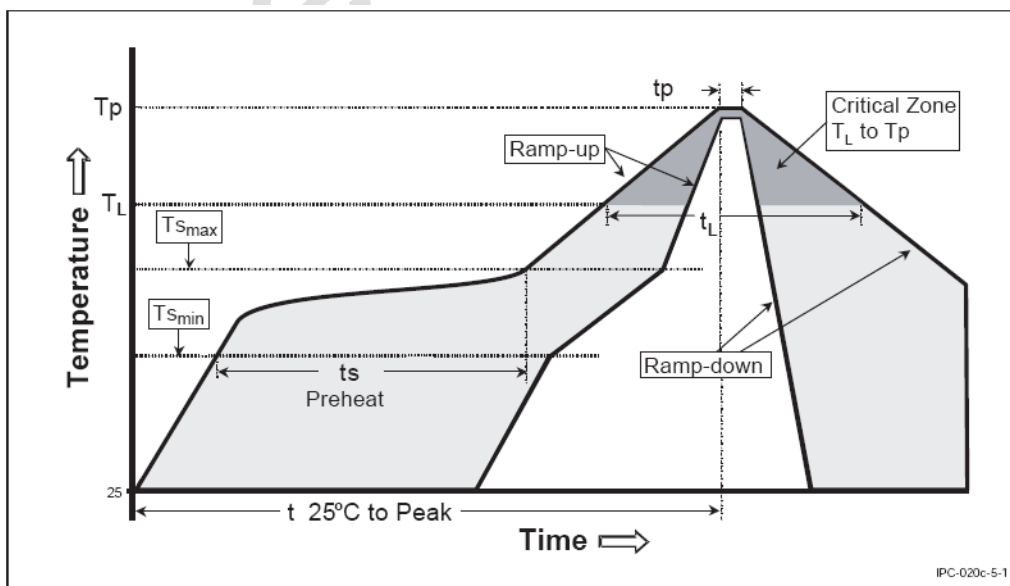

*According to J-STD-020C

6.5. Solder gun procedure

Note the follows, in case of using solder gun for replacement.

- (1) Use solder tip temperature must be less than 350°C for the period within 3 seconds by using soldering gun under 30W.
- (2) Soldering gun tip shall not touch component directly.

6.6. Soldering volume

Apply proper volume of solder paste, too much may cause crack of component body.

Preliminary

7. Taping Package and Label Marking

7.1. Carrier tape dimensions

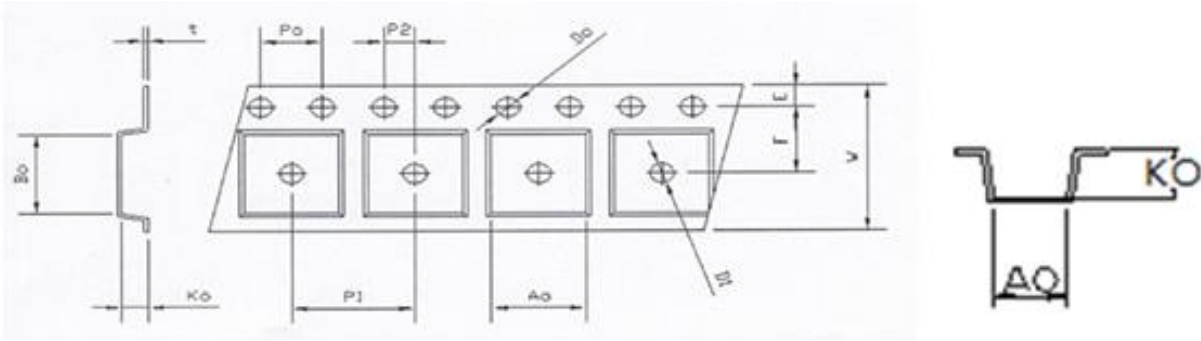

Type	W	E	F	D0	D1	P0	P1	P2	10Po
1812	12.00 ±0.15	1.75 ±0.10	5.5 ±0.10	1.55 ±0.10	1.55 ±0.10	4.00 ±0.10	8.00 ±0.10	2.00 ±0.10	40.00 ±0.20
	Bo	Ao	Ko	t					
	4.90 ±0.10	3.50 ±0.10	2.2 ±0.10	0.25 ±0.05					

Unit : mm

7.2. Taping reel dimensions

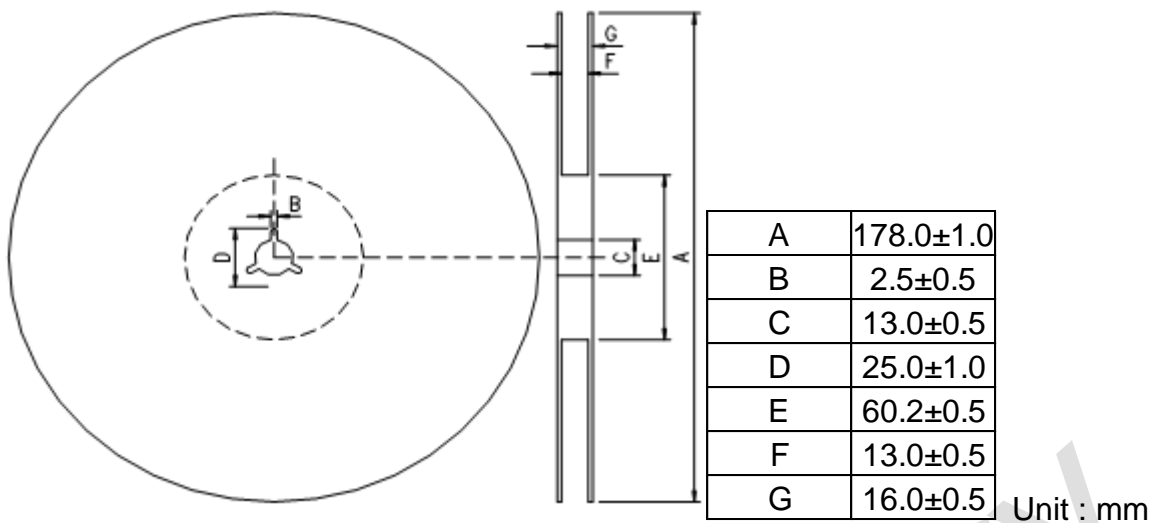

7.3. Taping specifications

There shall be the portion having no product in both the head and the end of taping, and there shall be the cover tape in the head of taping.

7.4. Label Marking

The label specified as follows shall be put on the side of reel.

- (1) Part No.
- (2) Quantity
- (3) Lot No.

Part No. And Quantity shall be marked on outer packaging.

7.5. Quantity of products in the taping package

- (1) Standard quantity: 1,000pcs/Reel

Shipping quantity is a multiple of standard quantity.