



MLVS 0603 AM Series Specification

Product Name	Multilayer Varistor
Series	MLVS AM Series
Size	EIA 0603



MLVS0603AM Series Engineering Specification

Multilayer Varistor for Automotive Applications

1. Scope

- (1) Qualified based on AEC-Q200
- (2) RoHS compliant
- (3) Meet IEC 61000-4-2 standard
- (4) SMD type zinc oxide based ceramic chip
- (5) Insulator over coat keeps excellent low and stable leakage current
- (6) Quick response time (<0.5ns)
- (7) High transient current capability
- (8) High reliability
- (9) Compact size for EIA0603

Applications

Protection against automotive related transient overvoltage

2. Explanation of Part Number

<u>MLV</u>	<u>S</u>	<u>0603</u>	<u>AM</u>	<u>14</u>	<u>150</u>
(1)	(2)	(3)	(4)	(5)	(6)

1. Multilayer varistor
2. Type: S=single; A=array
3. Size
4. Automotive series
5. Max. AC voltage
6. Typical Capacitance: "150" means $15 \times 10^0 = 15$

3. Construction & Dimension

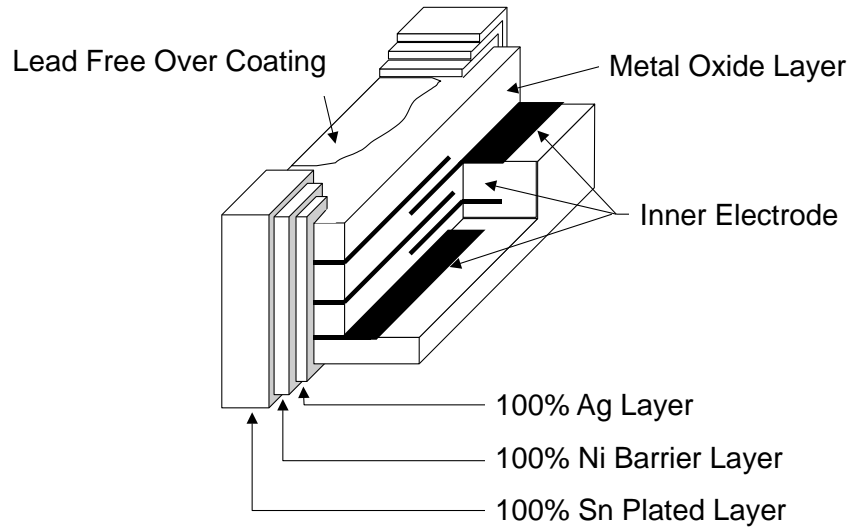
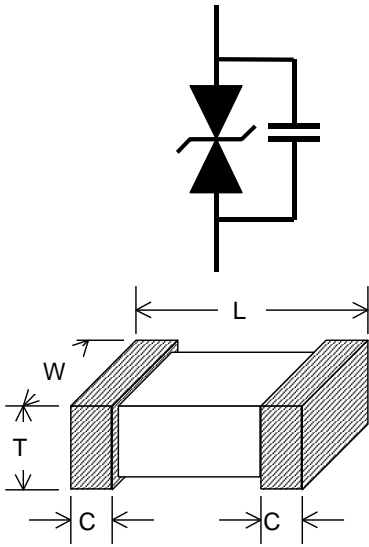

Unit: mm	0603
L	1.60±0.15
W	0.80±0.1
t	0.80±0.1
c	0.30±0.20

4. Part ratings and characteristics

4.1. Ratings (25°C for characteristics, 125°C for maximum ratings)

	Working voltage		Varistor voltage	Clamping Voltage	Capacitance	Peak current	Transient energy
Symbol	V_{RMS}	V_{DC}	V_V	V_c	C_p	i_{max}	W_{max}
Units	Volts	Volts	Volts	Volts	pF	Amps	Joules
	(Max.)	(Max.)		(Max.)	(Typical)	(Max.)	(Max.)
Test Condition		< 10 A	1mA DC	1A 8/20 s	1KHz	8/20 s	10/1000 s
MLVS0603AM02481	2.5	3.3	4 ~ 6.5	17	900[1MHz]	20	0.04
MLVS0603AM04301	4	5.5	6.4 ~ 9.7	21	375	30	0.1
MLVS0603AM06241	6	9	11 ~ 15.5	30	240[1MHz]	30	0.1
MLVS0603AM07241	7	9	11 ~ 15.5	30	240[1MHz]	30	0.1
MLVS0603AM11500	11	14	16.5 ~ 22	40	50[1MHz]	30	0.1
MLVS0603AM14150	14	16	23 ~ 34.2	70	15[1MHz]	5	0.03
MLVS0603AM14121	14	16	22 ~ 28	46	120	30	0.2
MLVS0603AM14300	14	17	21.6 ~ 34.4	70[2A]	30	2	0.05
MLVS0603AM14101	14	18	19.8 ~ 25.2	44	100	30	0.2
MLVS0603AM14111	14	18	19.8 ~ 24.2	40	110	30	0.2
MLVS0603AM14161	14	19	24 ~ 32	64[2A]	160	20	0.1
MLVS0603AM17750	17	22	25 ~ 41	54	75[1MHz]	30	0.075
MLVS0603AM17500	17	22	24.3 ~ 30.7	54	50[1MHz]	10	0.1
MLVS0603AM17101	17	22	24.3 ~ 30.7	50	100	30	0.2
MLVS0603AM17161	17	22	24.3 ~ 30.7	50	160	30	0.2
MLVS0603AM20800	20	26	30 ~ 43	67	80[1MHz]	30	0.1
MLVS0603AM25900	25	31	35 ~ 43.9	71	90	30	0.2
MLVS0603AM25120	25	32	51.9 ~ 71	124	12[1MHz]	5	0.1
MLVS0603AM30350	30	38	42 ~ 51	80	35[1MHz]	30	0.1

V_{RMS} – Maximum AC operating voltage the varistor can maintain and not exceed 10 μ A leakage current

V_{DC} – Maximum DC operating voltage the varistor can maintain and not exceed 10 μ A leakage current

V_V – Voltage across the device measured at 1mA DC current.
Equivalent to V_b , “Breakdown Voltage”.

V_c – Maximum peak voltage across the varistor measured at 8/20 μ s waveform and 1A pulse current

C_p – Device capacitance measured with zero volt bias 1Vrms.

i_{max} – Maximum peak current which may be applied with 8/20us waveform without device failure

W_{max} – Maximum energy that may be dissipated with the 10/1000us waveform without device failure

5. General electrical specifications

5.1. General technical data

Operating temperature	-40 ...+125°C
Storage temperature (on board)	-40... +125°C
Response time	<1 ns
Solderability	245±5°C, 5 +0/-0.5sec
Solder leach resistance	260±5°C, 10 ±1sec

5.2. Storage Condition with package

Storage Time: 12 months max

Storage Temperature: 5 to 40°C

Relative Humidity: 65% max

6. Taping Package and Label Marking

6.1. Carrier tape dimensions

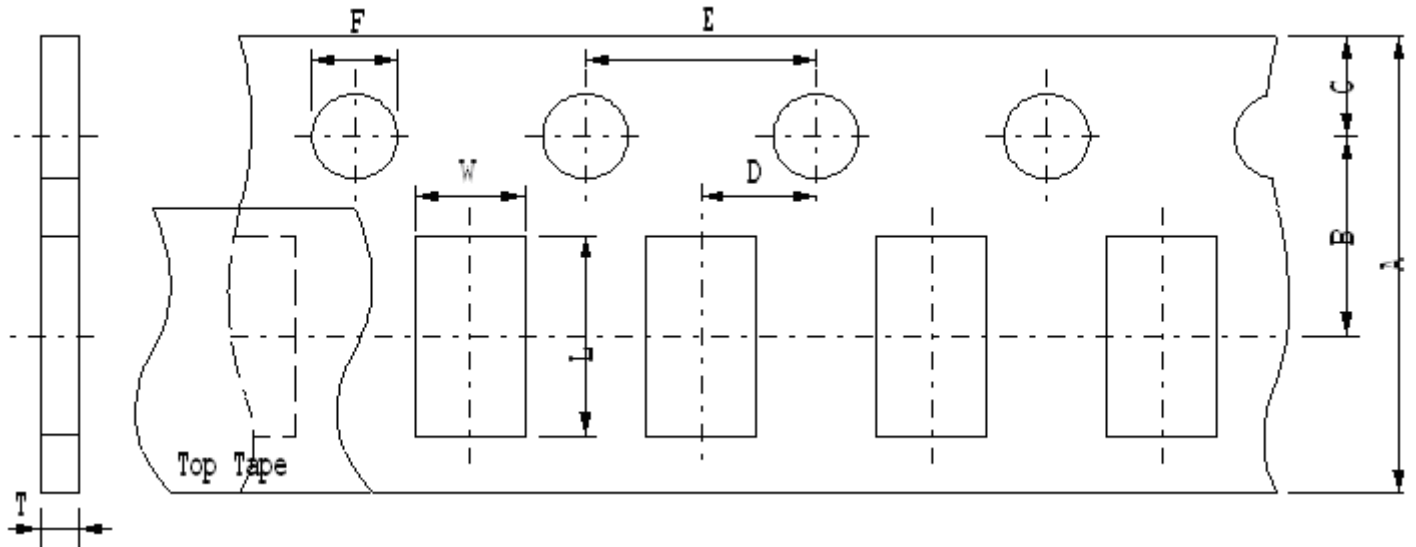

UNIT: mm

A	B	C	D	E	F	L	T	W
8.00±	3.50±	1.75±	2.00±	4.00±	1.50±	1.90±	0.95±	1.05±
0.30	0.05	0.10	0.05	0.10	0.10	0.15	0.05	0.15

6.2. Taping reel dimensions

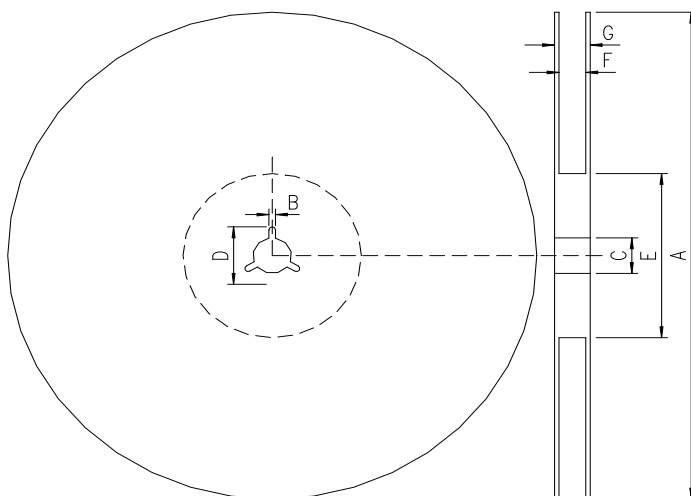

UNIT: mm

A	178.0±2.0
B	2.0±0.5
C	13.0±0.5
D	21.0±0.8
E	62.0±1.5
F	9.0±0.5
G	13.0±1.0

6.3. Taping specifications

There shall be the portion having no product in both the head and the end of taping, and there shall be the cover tape in the head of taping.

6.4. Label Marking

The label specified as follows shall be put on the side of reel.

- (1) Part No.
- (2) Quantity
- (3) Lot No.

*Part No. And Quantity shall be marked on outer packaging.

6.5. Quantity of products in the taping package

- (1) Standard quantity: 4,000pcs/Reel for MLVS0603AM series
- (2) Shipping quantity is a multiple of standard quantity.

7. Precautions for Handling

7.1. Solder cream in reflow soldering

Refer to the recommendable land pattern as printing mask pattern for solder cream.

- (1) Print solder in a thickness of 150 to 200 μm .
- (2) Dimensions: millimeters (inches)

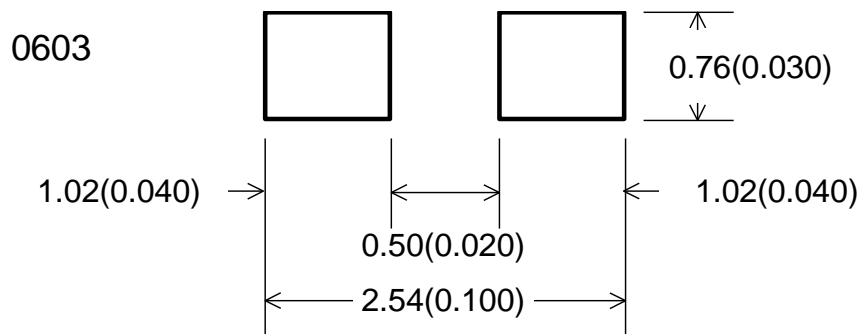

7.2. Precaution for handling of substrate

Do not exceed to bend the board after soldering this product extremely.

(Reference examples)

- Mounting place must be as far as possible from the position, which is close to the break line of board, or on the line of large holes of board.
- Do not bend extremely the board, in mounting another component.
If necessary, use back-up pin (support pin) to prevent from bending extremely.
- Do not break the board by hand. We recommend using the machine or the jig to break it.

7.3. Precaution for soldering

Note that rapid heating, rapid cooling or local heating will easily damage this product.

Do not give heat shock over 100°C in the process of soldering. We recommend taking preheating and gradual cooling.

7.4. Recommendable reflow soldering

Profile Feature	Pb-Free Assembly
Average Ramp-Up Rate (T _{smax} to T _p)	3° C/second max.
Preheat – Temperature Min (T _{smin}) – Temperature Max (T _{smax}) – Time (t _{smin} to t _{smax})	150°C 200°C 60-180 seconds
Time maintained above: – Temperature (T _L) – Time (t _L)	217°C 60-150 seconds
Peak/Classification Temperature (T _p)	260°C
Time within 5 °C of actual Peak Temperature (t _p)	20-40 seconds
Ramp-Down Rate	6°C/second max.
Time 25 °C to Peak Temperature	8 minutes max.

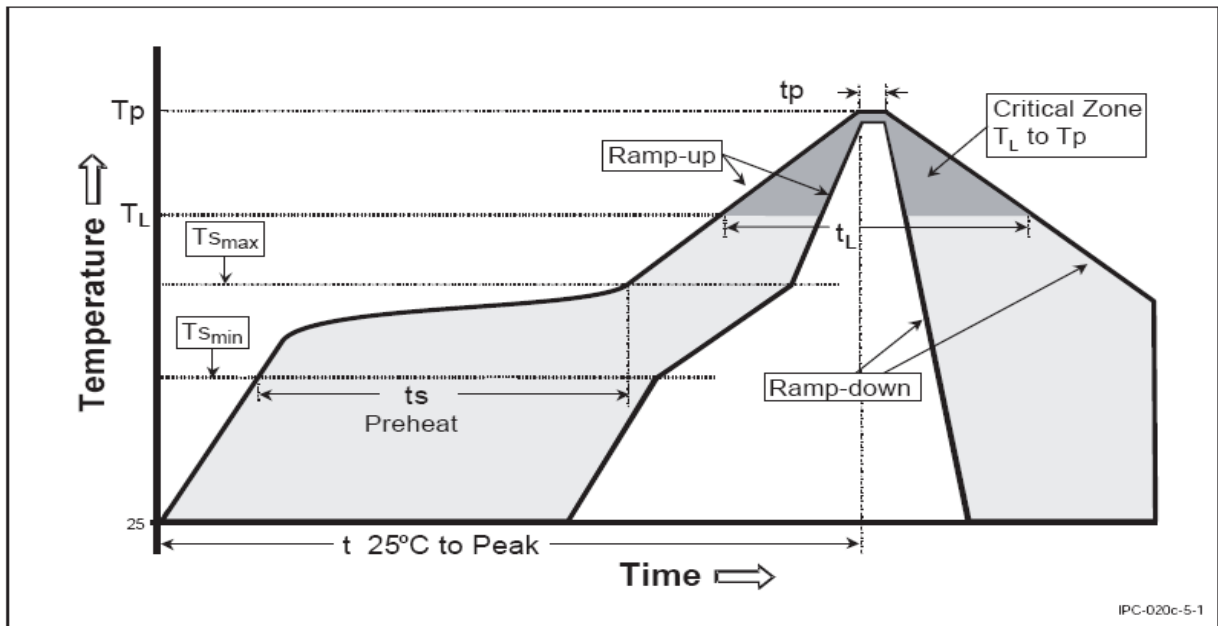

*According to J-STD-020C

7.5. Soldering gun procedure

Note the follows, in case of using solder gun for replacement.

- (1) The tip temperature must be less than 350°C for the period within 3 seconds by using soldering gun less than 30 W.
- (2) The soldering gun tip shall not touch this product directly.

7.6. Soldering volume

Note that excess of soldering volume will easily get crack the body of this product.