



SM820C thru SM8200C



Schottky Barrier Rectifiers



DO-214AB(SMC)

Features
<ul style="list-style-type: none"> • Low profile package • Ideal for automated placement • Guard Ring for over voltage protection • Low forward voltage drop • Component in accordance to RoHS 2002/95/EC • AEC-Q101 qualified

Ordering Information		
Part No.	Package	Packing
SM8xxxC	SMC	3000 / Tape & Reel

Device P/N	
Part Number	Remark
SM8xxxC	General
SM8xxxC-H	Halogen Free
SM8xxxC-Q	Automotive

Primary Characteristics		
I_F	8	A
V_{RRM}	20~200	V
I_{FSM}	125	A
V_F	0.55,0.70,0.85,0.87,0.90	V
T_J max	125,150	°C

Mechanical Data
• Case: DO-214AB (SMC)
• Case Material: Molded Plastic. UL Flammability Classification Rating 94V-0
• Terminals: Lead Free Plating (Tin Finish). Solderable per MIL-STD-202, Method 208
• Polarity: Cathode Band
• Weight: 0.231 grams (approximate)

Maximum Ratings (TA=25°C unless otherwise noted)											
PARAMETER	SYMBOL	SM 820C	SM 830C	SM 840C	SM 850C	SM 860C	SM 880C	SM 8100C	SM 8150C	SM 8200C	UNIT
Maximum repetitive peak reverse voltage	V_{RRM}	20	30	40	50	60	80	100	150	200	V
Maximum RMS voltage	V_{RMS}	14	21	28	35	42	56	70	105	140	V
Maximum DC blocking voltage	V_{DC}	20	30	40	50	60	80	100	150	200	V
Maximum average forward rectified current	I_F	8									A
Peak forward surge current, 8.3ms single half sine-wave superimposed on rated load	I_{FSM}	125									A
Maximum Instantaneous Forward Voltage IF=8A @ 25°C	V_F	0.55			0.70		0.85		0.87	0.90	V
Maximum DC Reverse Current @ TA=25°C at Rated DC Blocking Voltage @ TA=100°C	I_R	0.5 30					0.2 10				mA
Typical Junction Capacitance(NOTE1)	C_j	340			250		210		180	150	pF
Typical Thermal Resistance	$R_{\theta Ja}$ $R_{\theta Jc}$	50 30									°C/W
Operating Temperature Range	T_J	-55 to +125					-55 to +150				°C
Storage Temperature Range	T_{STG}	-55 to +150									°C
Marking Code		SM 820C	SM 830C	SM 840C	SM 850C	SM 860C	SM 880C	SM 8100C	SM 8150C	SM 8200C	

NOTES:

1.Measured at 1.0MHZ and applied reverse voltage of 4.0V DC



Schottky Barrier Rectifiers

Rating and Characteristics Curvers

FIG. 1-Typical Forward Current Derating Curve

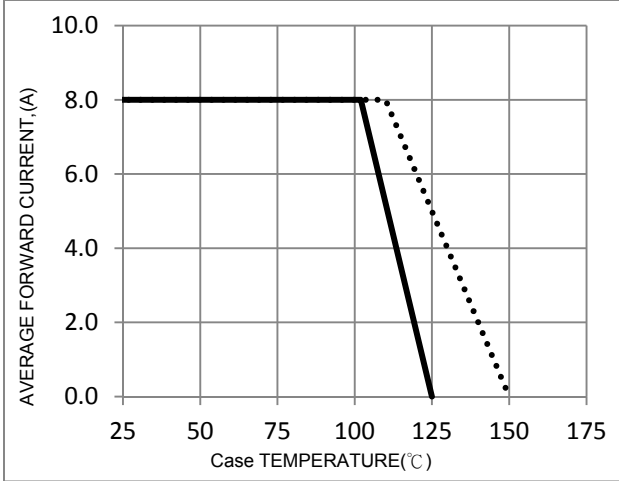

FIG. 2-Typical Forward Characteristics

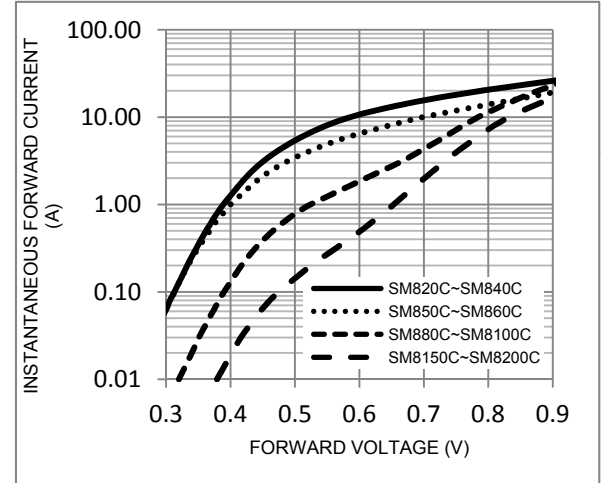

FIG. 3-Maximum Non-Repetitive Forward Surge Current

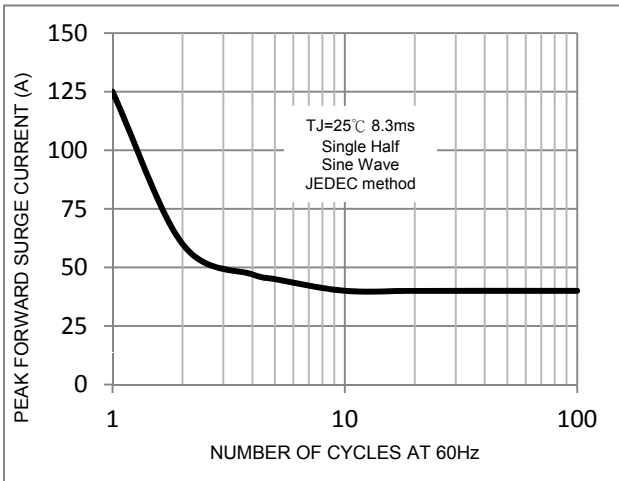

FIG. 4-Typical Reverse Characteristics

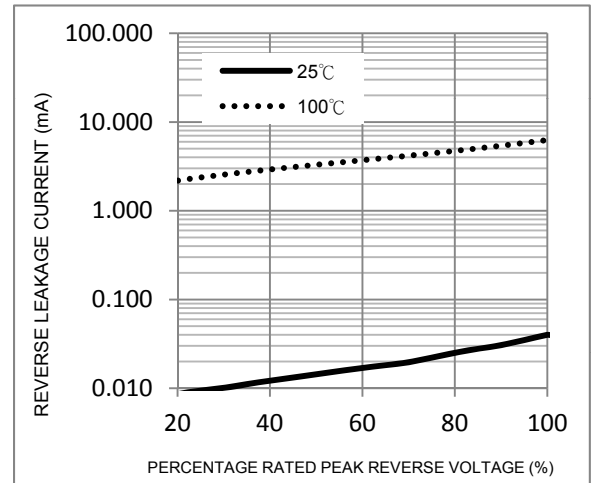
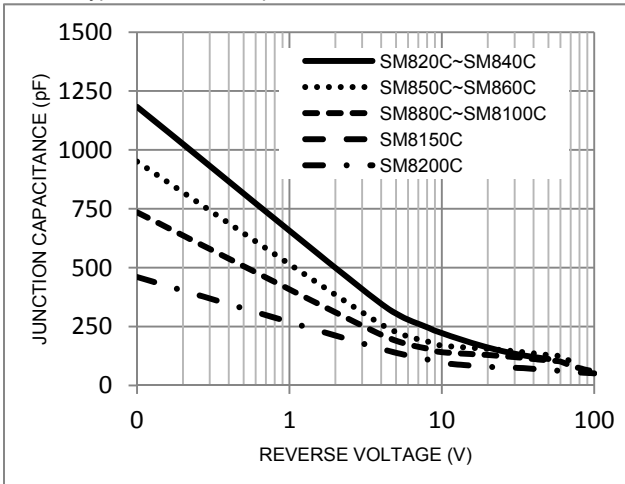

FIG. 5-Typical Junction Capacitance





SM820C thru SM8200C



Schottky Barrier Rectifiers

Package Outline Dimensions

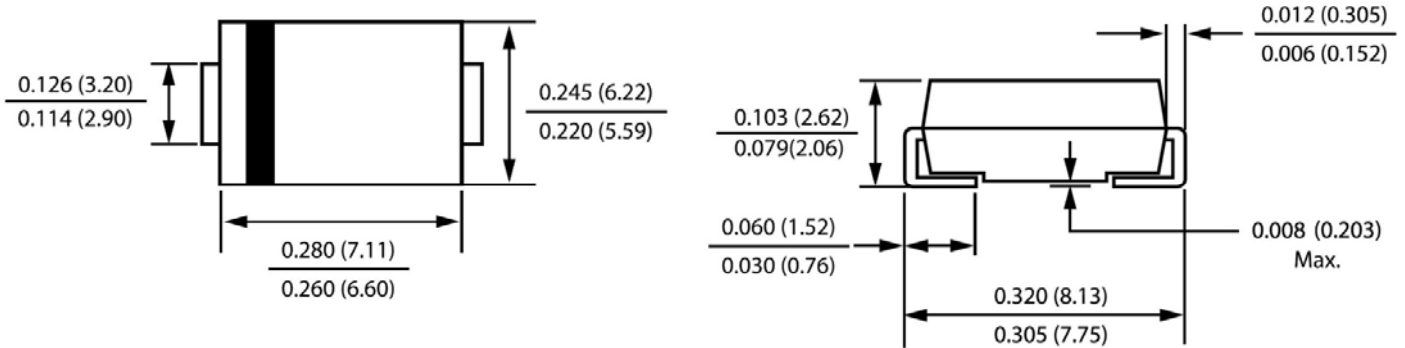

DO-214AB(SMC)

Dimensions in inches and (millimeters)

Marking Information

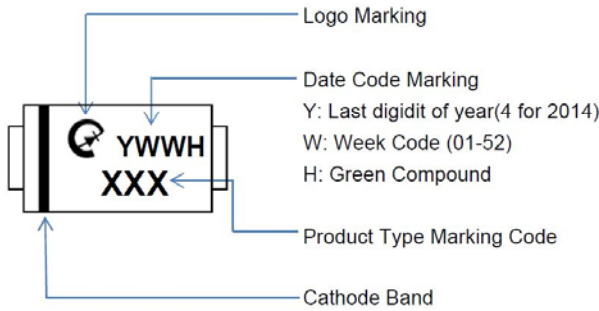

Suggested Pad Layout

Dimension	Outline	SMC (DO-214AB)
A		9.40
B		4.40
C		3.30
D		2.50
E		6.80

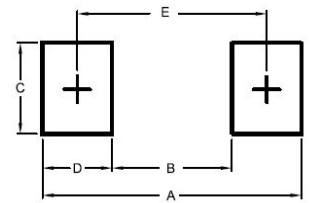

Tap & Reel Specification

ITEM	SYMBOL	SMC (mm)
		DO-214AB
Carrier width	A	6.3(max)
Carrier length	B	8.6(max)
Carrier depth	C	2.9(max)
Sprocket hole	d	1.50±0.1
Reel outside diameter	D	330±2.0
Feed hole diameter	D0	13.5±1
Reel inner diameter	D1	50 (min.)
Sprocket hole position	E	1.75±0.1
Punch hole position	F	7.5±0.05
Sprocket hole pitch	P	8.0±0.1
Sprocket hole pitch	Po	4.0±0.1
Embossment center	P1	2.0±0.05
Overall tape thickness	T	0.6 (max)
Tape width	W	16.0±0.3
Reel width	W2	22.4 (max)
Reel width	W1	18.4 (max)

