



NJW4109

45 V, I_o = 500 mA LDO WITH POWER-GOOD

■ FEATURES

- Fast transient response
- Wide operating voltage 4.0 V to 40 V
- Wide operating temperature T_a = -40°C to 125°C
- Output voltage accuracy V_O ±1.0%
(V_{IN} = V_O + 1 V to 40 V, I_o = 0 mA to 500 mA, T_a = 25°C)
- Output current 500 mA (min)
- ON/OFF control
- Ceramic capacitor compatible
- Power-good output
- Undervoltage lockout (UVLO)
- Thermal shutdown
- Overcurrent protection
- Package TO-252-5-L5

■ APPLICATIONS

- Car infotainment
- Active antenna power supplies
- Automotive camera power supplies
- External power supplies for industrial equipment

■ DESCRIPTION

The NJW4109 is a 45 V, I_o = 500 mA low dropout regulator with power-good. Power-good outputs whether the output voltage is within the normal range as a flag and notifies the MCU of the abnormal state. This device achieves fast transient response and offers stable output voltage even at line or load fluctuations.

The NJW4109 provides outstanding high output voltage accuracy that guaranteed ±1.0% under the conditions of V_{IN} = V_O + 1 V to 40 V, I_o = 0 mA to 500 mA.

Moreover, wide operating voltage, wide operating temperature, and power-good output make the NJW4109 ideal for automotive equipment or applications that require high reliability.

■ TYPICAL APPLICATION

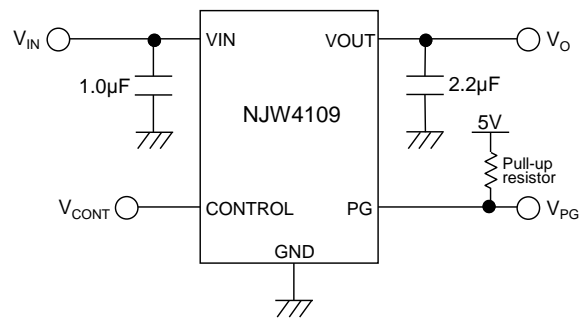

■ PRODUCT INFORMATION

PRODUCT NAME	FUNCTION
NJW4109DL5-A	PG detection of V _O due to V _{IN} drop is valid
NJW4109DL5-B	PG detection of V _O due to V _{IN} drop is invalid

■ BLOCK DIAGRAM

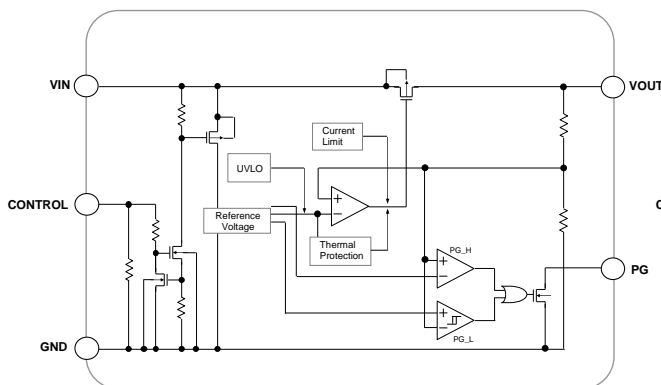

A-Version

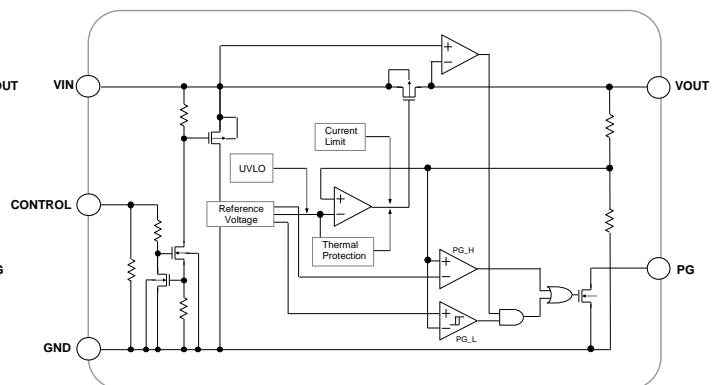

B-Version

■ OUTPUT VOLTAGE RANK

PRODUCT NAME	OUTPUT VOLTAGE
NJW4109DL5-08A	8.0V
NJW4109DL5-08B	8.0V

■ PIN CONFIGURATION

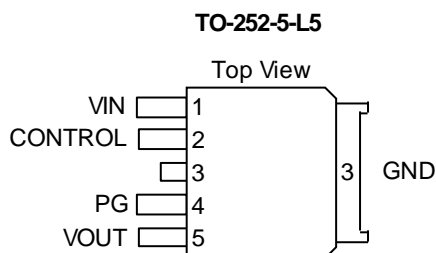

PIN NO.	NAME	FUNCTION
1	VIN	Input pin
2	CONTROL	ON/OFF control pin (active high)
3	GND	Ground pin
4	PG	Power-good pin (N-channel open-drain)
5	VOUT	Output pin

■ PRODUCT NAME INFORMATION

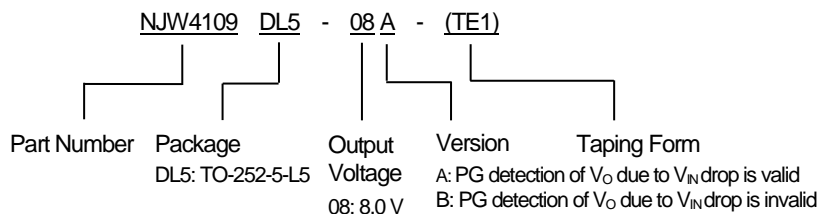

■ ORDERING INFORMATION

PRODUCT NAME	PACKAGE	RoHS	HALOGEN-FREE	TERMINAL FINISH	MARKING	WEIGHT (mg)	MOQ (pcs)
NJW4109DL5-08A (TE1)	TO-252-5-L5	Yes	Yes	Sn-2Bi	109A08	301	3000
NJW4109DL5-08B (TE1)	TO-252-5-L5	Yes	Yes	Sn-2Bi	109B08	301	3000

■ ABSOLUTE MAXIMUM RATINGS

PARAMETER	SYMBOL	RATING	UNIT
Input Voltage	V_{IN}	-0.3 to 45	V
Control Pin Voltage	V_{CONT}	-0.3 to 45	V
Output Voltage	V_O	-0.3 to $V_{IN} \leq +17$ ⁽¹⁾	V
Power-Good Pin Voltage	V_{PG}	-0.3 to 45	V
Power Dissipation ($T_a = 25^\circ\text{C}$) TO-252-5-L5	P_D	2-Layer / 4-Layer / High Power 4-Layer 890 ⁽²⁾ / 3200 ⁽³⁾ / 5200 ⁽⁴⁾	mW
Junction Temperature	T_j	-40 to 150	$^\circ\text{C}$
Storage Temperature	T_{stg}	-50 to 150	$^\circ\text{C}$

(1) When the input voltage is less than 17 V, the absolute maximum output voltage is equal to the input voltage. If the input voltage is below 17 V, the maximum output voltage is 17 V.

(2) 2-Layer: Mounted on glass epoxy board (76.2 mm × 114.3 mm × 1.6 mm: based on EIA/JEDEC standard, 2-layer FR-4).

(3) 4-Layer: Mounted on glass epoxy board (76.2 mm × 114.3 mm × 1.6 mm: based on EIA/JEDEC standard, 4-layer FR-4).
(For 4-layer: Applying 74.2 mm × 74.2 mm inner Cu area and a thermal via hole to a board based on JEDEC standard JESD51-5.)

(4) High Power 4-Layer: Mounted on glass epoxy board (76.2 mm × 114.3 mm × 1.6 mm, 4-layer FR-4).

(For 4-layer: Applying 74.2 mm × 74.2 mm inner Cu area and a thermal via hole to a board based on JEDEC standard JESD51-5.)

*For the specifications of each board, see the BOARD SPECIFICATIONS.

■ RECOMMENDED OPERATING CONDITIONS

PARAMETER	SYMBOL	VALUE	UNIT
Operating Voltage	V_{IN}	4.0 to 40	V
Control Voltage	V_{CONT}	0 to 40	V
Output Current	I_O	0 to 500	mA
Power-Good Pin Voltage	V_{PG}	0 to 40	V
Operating Temperature	T_{opr}	-40 to 125	$^\circ\text{C}$

■ ELECTRICAL CHARACTERISTICS

 $V_{IN} = V_O + 1\text{ V}$, $C_{IN} = 1.0\ \mu\text{F}$, $C_O = 2.2\ \mu\text{F}$, $T_a = 25^\circ\text{C}$, unless otherwise noted.

PARAMETER	SYMBOL	TEST CONDITIONS	MIN	TYP	MAX	UNIT		
LDO REGULATOR								
Output Voltage	V_O	$V_{IN} = V_O + 1\text{ V}$ to 40 V, $I_O = 0\text{ mA}$ to 500 mA	-1.0%	-	+1.0%	V		
Quiescent Current	I_Q	$I_O = 0\text{ mA}$, except I_{CONT}	-	90	130	μA		
Quiescent Current at Control OFF	$I_{Q(OFF)}$	$V_{CONT} = 0\text{ V}$	-	-	3	μA		
Output Current	I_O	$V_O \times 0.9$	500	-	-	mA		
Line Regulation	$\Delta V_O / \Delta V_{IN}$	$V_{IN} = V_O + 1\text{ V}$ to 40 V, $I_O = 30\text{ mA}$						
				$V_O = 8\text{ V}$	-	-	52.5	mV
Load Regulation	$\Delta V_O / \Delta I_O$	$I_O = 0\text{ mA}$ to 500 mA						
				$V_O = 8\text{ V}$	-	-	36.0	mV
Ripple Rejection	RR	$V_{IN} = V_O + 1\text{ V}$, $e_{in} = 200\text{ mVrms}$, $f = 1\text{ kHz}$, $I_O = 10\text{ mA}$						
				$V_O = 8\text{ V}$	-	50	-	dB
Dropout Voltage 1	ΔV_{IO1}	$I_O = 300\text{ mA}$	-	0.24	0.42	V		
Dropout Voltage 2	ΔV_{IO2}	$I_O = 500\text{ mA}$	-	0.40	0.70	V		
Average Temperature Coefficient of Output Voltage	$\Delta V_O / \Delta T_a$	$T_a = -40^\circ\text{C}$ to 125°C , $I_O = 30\text{ mA}$	-	± 50	-	ppm/ $^\circ\text{C}$		
CONTROL								
Control Current	I_{CONT}	$V_{CONT} = 1.6\text{ V}$	-	0.5	2.0	μA		
Output ON Control Voltage	$V_{CONT(ON)}$		1.6	-	-	V		
Output OFF Control Voltage	$V_{CONT(OFF)}$		-	-	0.6	V		
UNDERVOLTAGE LOCKOUT (UVLO)								
UVLO Release Voltage	V_{UVLO}	$V_{IN} = \text{Sweep Up}$	2.3	2.7	3.1	V		
UVLO Hysteresis Voltage	V_{UVLO_HYS}	$V_{IN} = \text{Sweep Down}$	200	500	-	mV		
POWER-GOOD								
High-Level Detection Voltage	V_{THL_PG}	$V_O = \text{Sweep Up}$	105	110	115	%		
Low-Level Detection Voltage	V_{THL_PG}	$V_O = \text{Sweep Down}$	85	90	95	%		
Low-Level Release Hysteresis Voltage	V_{HYS_PG}	$V_O = \text{Sweep Up}$	1	2	-	%		
Leakage Current at OFF	I_{LEAK_PG}	$V_{PG} = 5\text{ V}$	-	-	0.3	μA		
Power-Good ON-Resistance	R_{ON_PG}	$I_{PG} = 4\text{ mA}$	-	220	280	Ω		

■ THERMAL CHARACTERISTICS

PARAMETER	SYMBOL	VALUE	UNIT
Junction-To-Ambient Thermal Resistance TO-252-5-L5	θ_{ja}	2-Layer / 4-Layer / High Power 4-Layer 140 ⁽⁵⁾ / 39 ⁽⁶⁾ / 24 ⁽⁷⁾	°CW
Junction-To-Top of Package Characterization Parameter TO-252-5-L5	ψ_{jt}	2-Layer / 4-Layer / High Power 4-Layer 27 ⁽⁵⁾ / 12 ⁽⁶⁾ / 9 ⁽⁷⁾	°CW

■ BOARD SPECIFICATIONS

BOARD		JEDEC 2-LAYER BOARD	JEDEC 4-LAYER BOARD	HIGH POWER 4-LAYER BOARD
Dimension		76.2 mm × 114.3 mm, t = 1.6 mm		
Material		FR-4		
Cu Area	Surface Layer (Thickness: 70 μm)	Recommended land pattern + Measurement wiring	Recommended land pattern + Measurement wiring	Recommended land pattern + Heat dissipation pattern (50 mm × 50 mm) + Measurement wiring
	2 nd Layer (Thickness: 35 μm)	-	74.2 mm × 74.2 mm	74.2 mm × 74.2 mm
	3 rd Layer (Thickness: 35 μm)	-	74.2 mm × 74.2 mm	74.2 mm × 74.2 mm
	Back Layer (Thickness: 70 μm)	-	-	74.2 mm × 74.2 mm
Thermal Vias		-	Connected from surface layer to 2 nd layer	All layers are connected

■ POWER DISSIPATION vs. AMBIENT TEMPERATURE

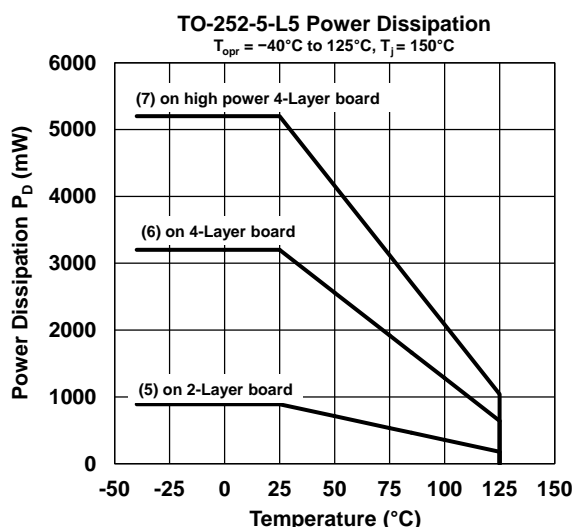

- (5) 2-Layer: Mounted on glass epoxy board (76.2 mm × 114.3 mm × 1.6 mm: based on EIA/JEDEC standard, 2-layer FR-4).
- (6) 4-Layer: Mounted on glass epoxy board (76.2 mm × 114.3 mm × 1.6 mm: based on EIA/JEDEC standard, 4-layer FR-4).
 (For 4-layer: Applying 74.2 mm × 74.2 mm inner Cu area and a thermal via hole to a board based on JEDEC standard JESD51-5.)
- (7) High Power 4-Layer: Mounted on glass epoxy board (76.2 mm × 114.3 mm × 1.6 mm, 4-layer FR-4).
 (For 4-layer: Applying 74.2 mm × 74.2 mm inner Cu area and a thermal via hole to a board based on JEDEC standard JESD51-5.)

■ TYPICAL CHARACTERISTICS

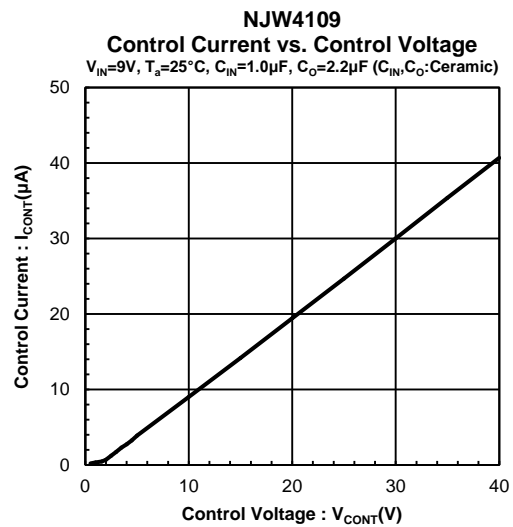
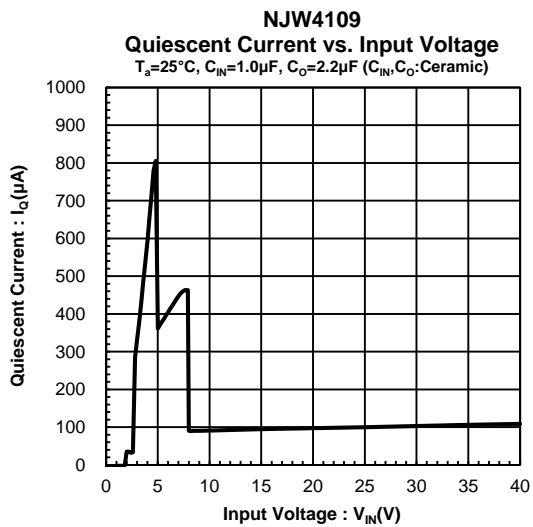
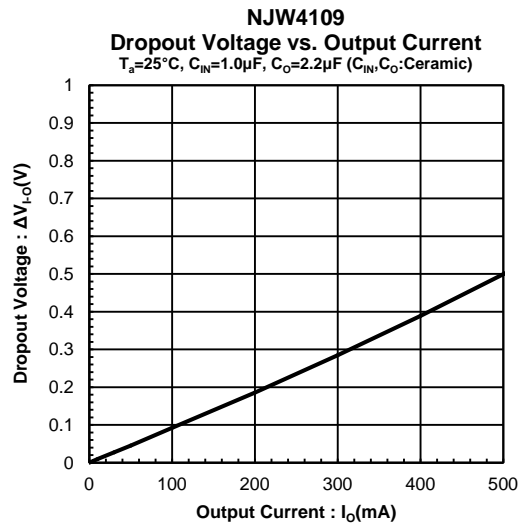
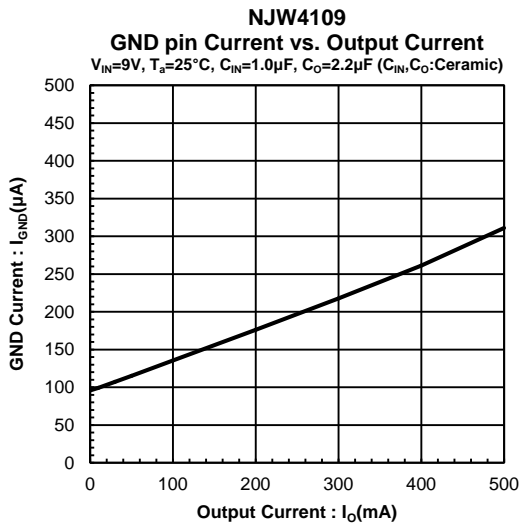
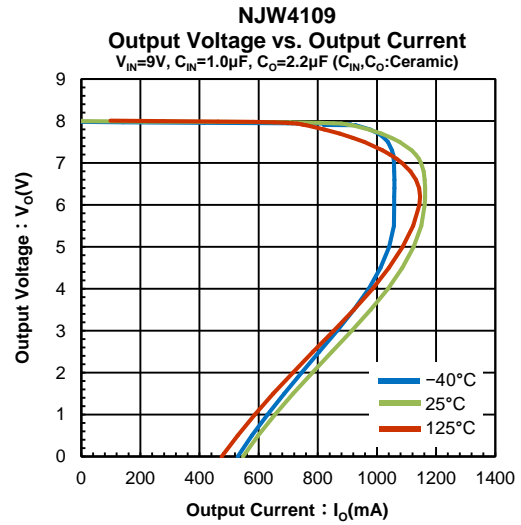
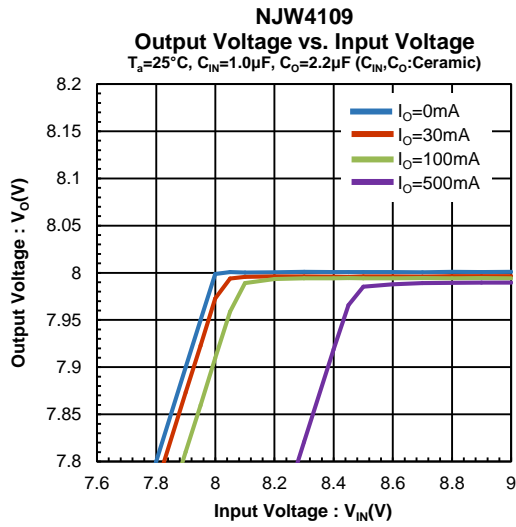

■ TYPICAL CHARACTERISTICS

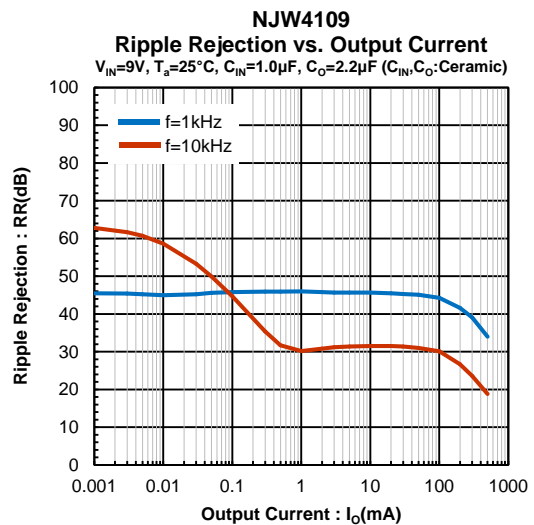
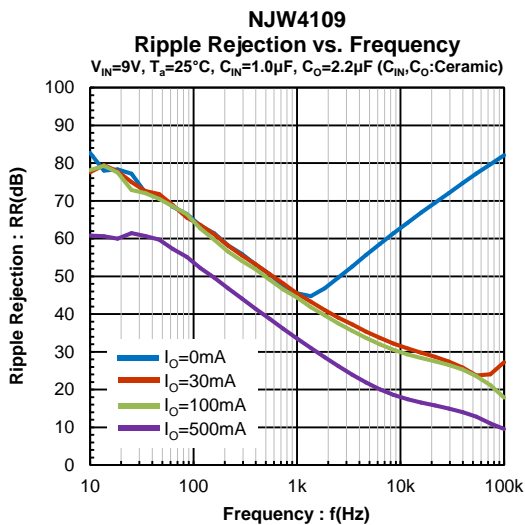
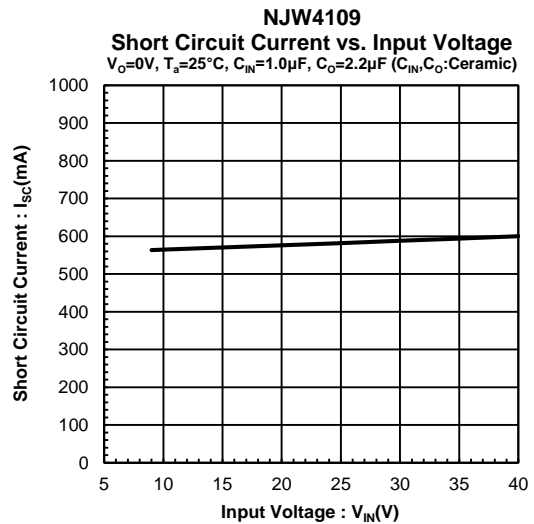
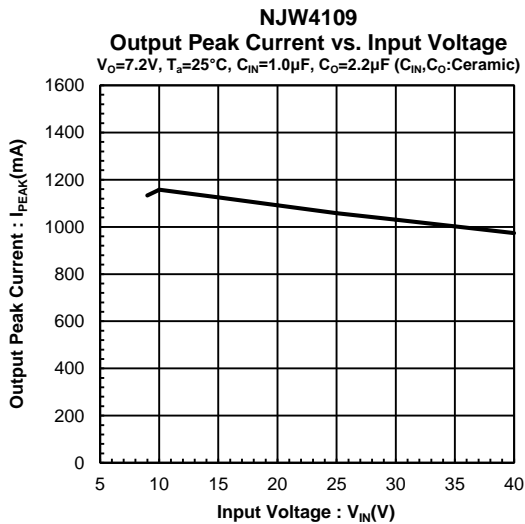
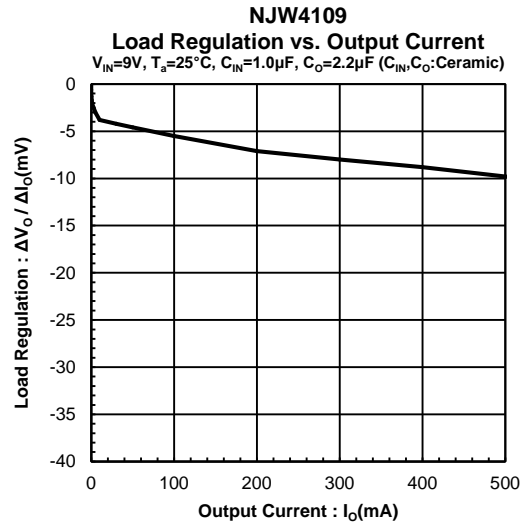
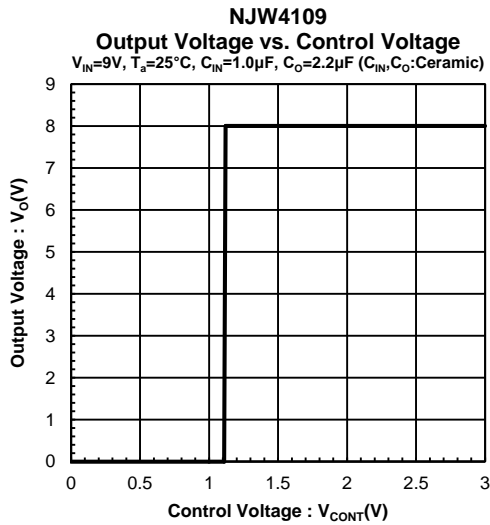

■ TYPICAL CHARACTERISTICS

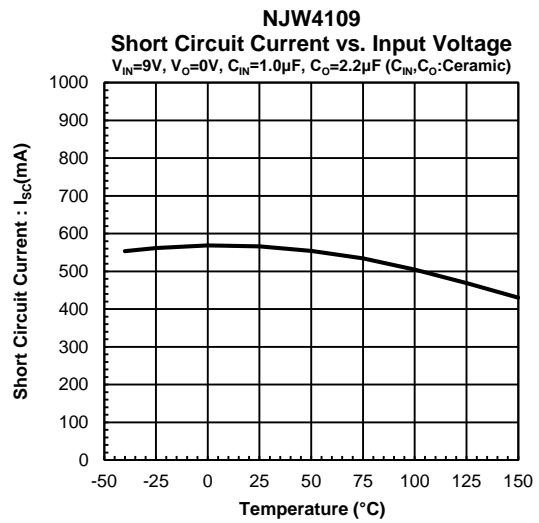
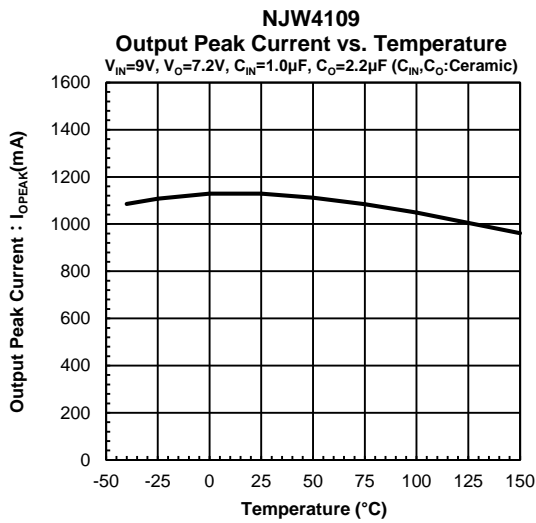
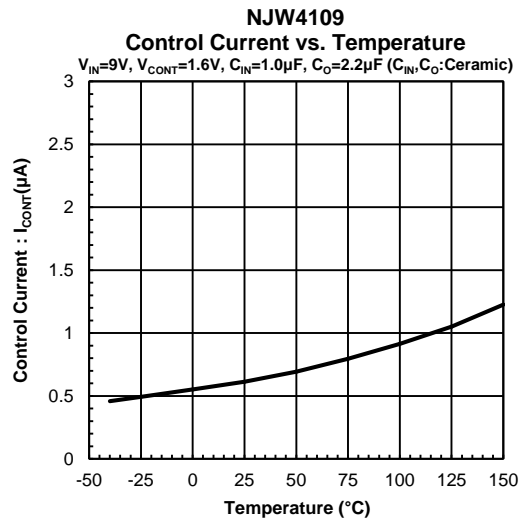
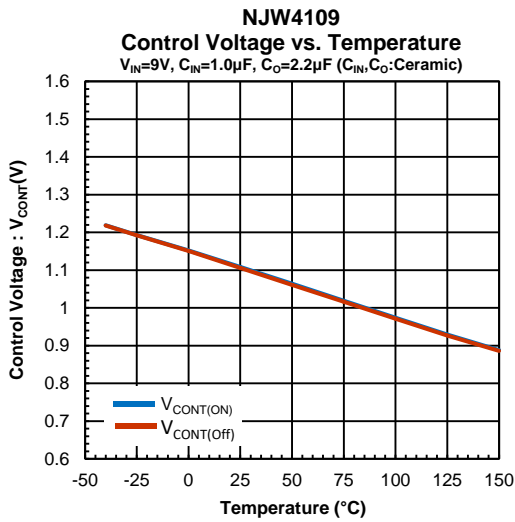
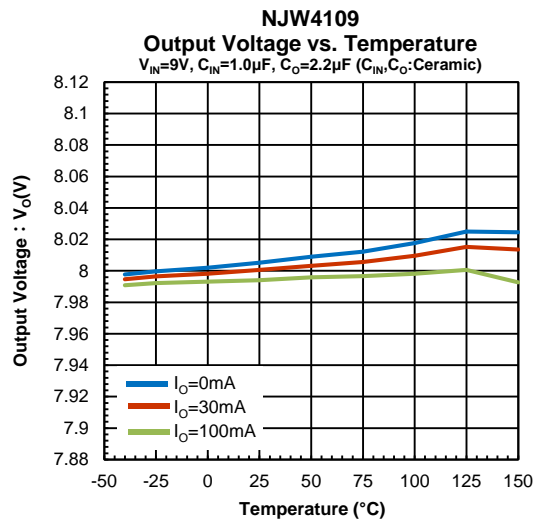
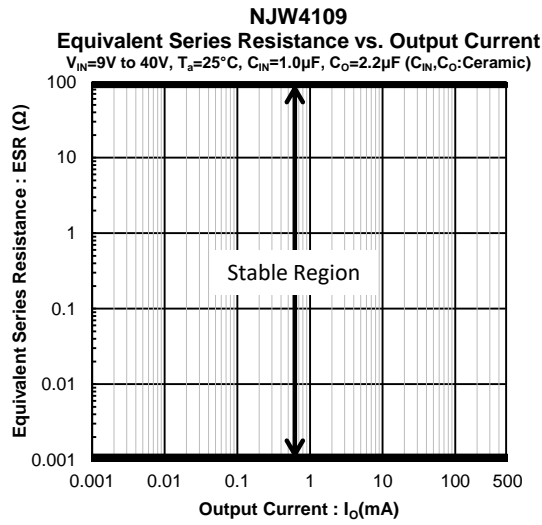

■ TYPICAL CHARACTERISTICS

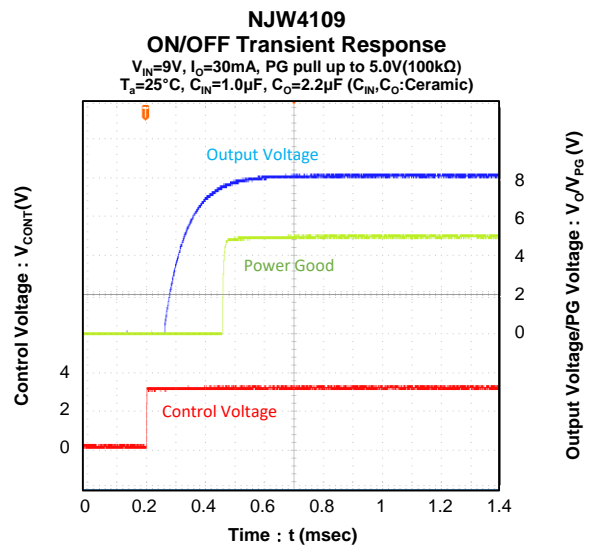
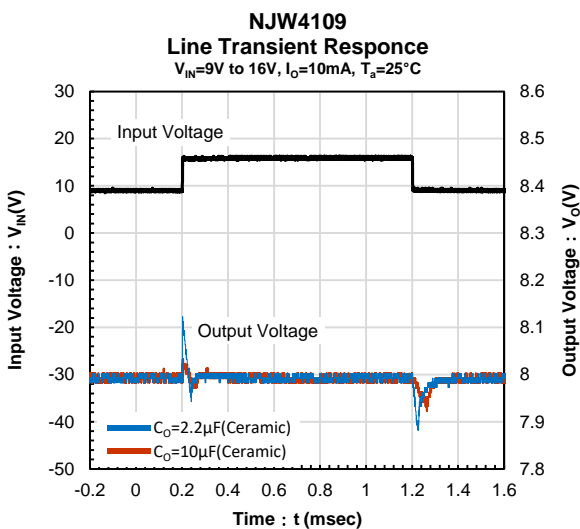
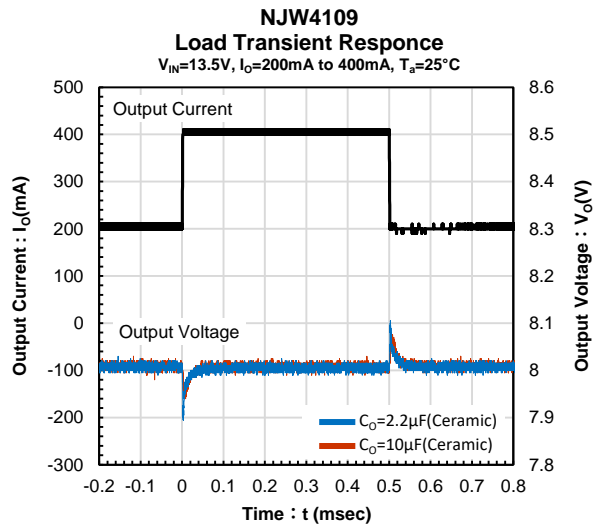
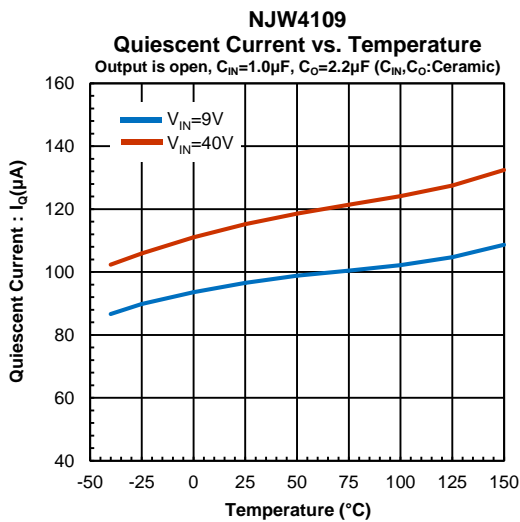
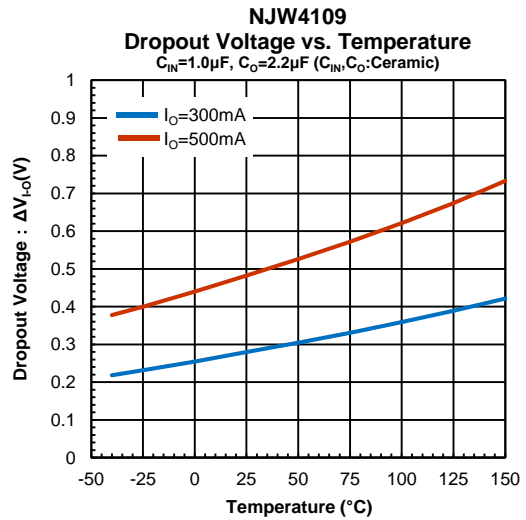
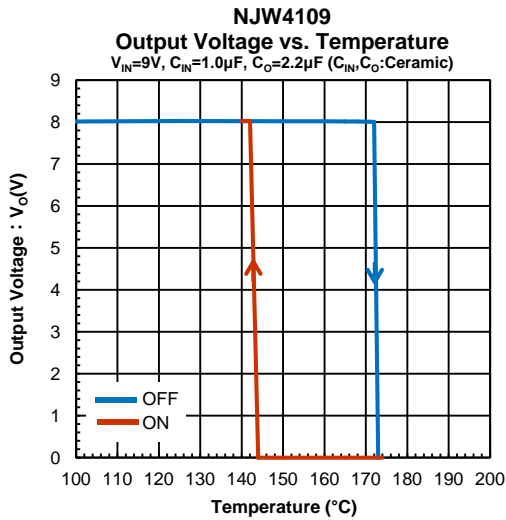

■ TYPICAL APPLICATION

① When ON/OFF control is used.

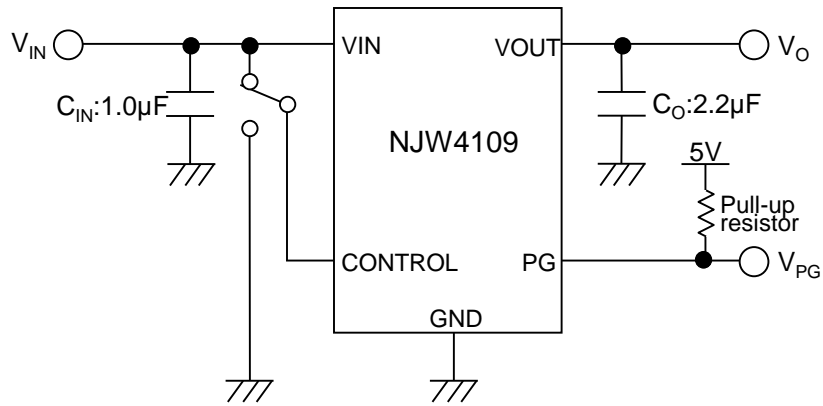

The CONTROL pin is turned on at high level and turned off at open or GND level.

② When ON/OFF control is not used.

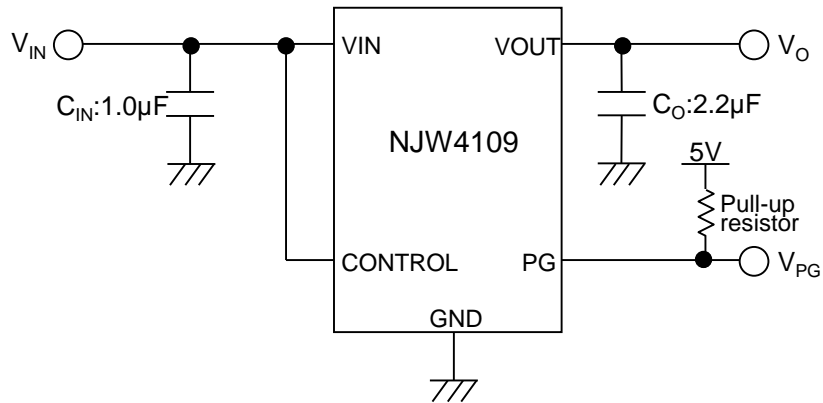

Connect the CONTROL pin to the VIN.

■ APPLICATION NOTE

Input Capacitor (C_{IN})

The C_{IN} prevents oscillations and reduce power supply ripple of applications when the power supply impedance is high or power supply line is long. Connecting a 1.0 μF or larger C_{IN} between V_{IN} and GND pins as short path as possible.

Output Capacitor (C_O)

C_O is necessary for phase compensation of the internal error amplifier in the regulator, and the capacitance value and ESR affect the stability of the circuit. If a capacitor less than 2.2 μF is used, output noise and/or regulator oscillation may occur due to lack of the phase compensation. For stable operation, connect a 2.2 μF or larger C_O within the stable operation region (0.001 Ω ≤ ESR ≤ 100 Ω) between the V_{OUT} and GND pins as short path as possible. The recommended capacitance value varies depending on the output voltage, and a low output voltage may require a large capacitance value; therefore, confirm the recommended capacitance of the required output voltage. As the capacitance value of C_O increases, output noise and ripple decrease, and the response to output load fluctuations also improves.

Select the output capacitor considering various characteristics such as frequency characteristics, temperature characteristics, and DC bias characteristics. For the C_O, a capacitor with excellent temperature characteristics and sufficient margin for output voltage is recommended.

Power-Good Output (PG)

The PG monitors the output status and outputs a signal from the open-drain PG pin. When the V_{OUT} pin is stable at 90% (typ) < V_O < 110% (typ), the power-good output becomes high impedance. The power-good output goes low when V_O ≤ 90% or V_O ≥ 110%.

The NJW4109 is available in two versions, and can select whether to monitor the output voltage fluctuations caused by a drop in V_{IN}. The A-version outputs a PG signal when the V_O falls below the set value due to a drop in V_{IN}. The B-version does not output a PG signal even when the V_O falls below the set value due to a drop in V_{IN}. The following timing chart shows the difference between the operation of the A and B versions. To prevent malfunction of power-good output, a delay time of approximately 20 μs and 2% (typ) hysteresis for release from undervoltage detection are provided.

Timing Chart

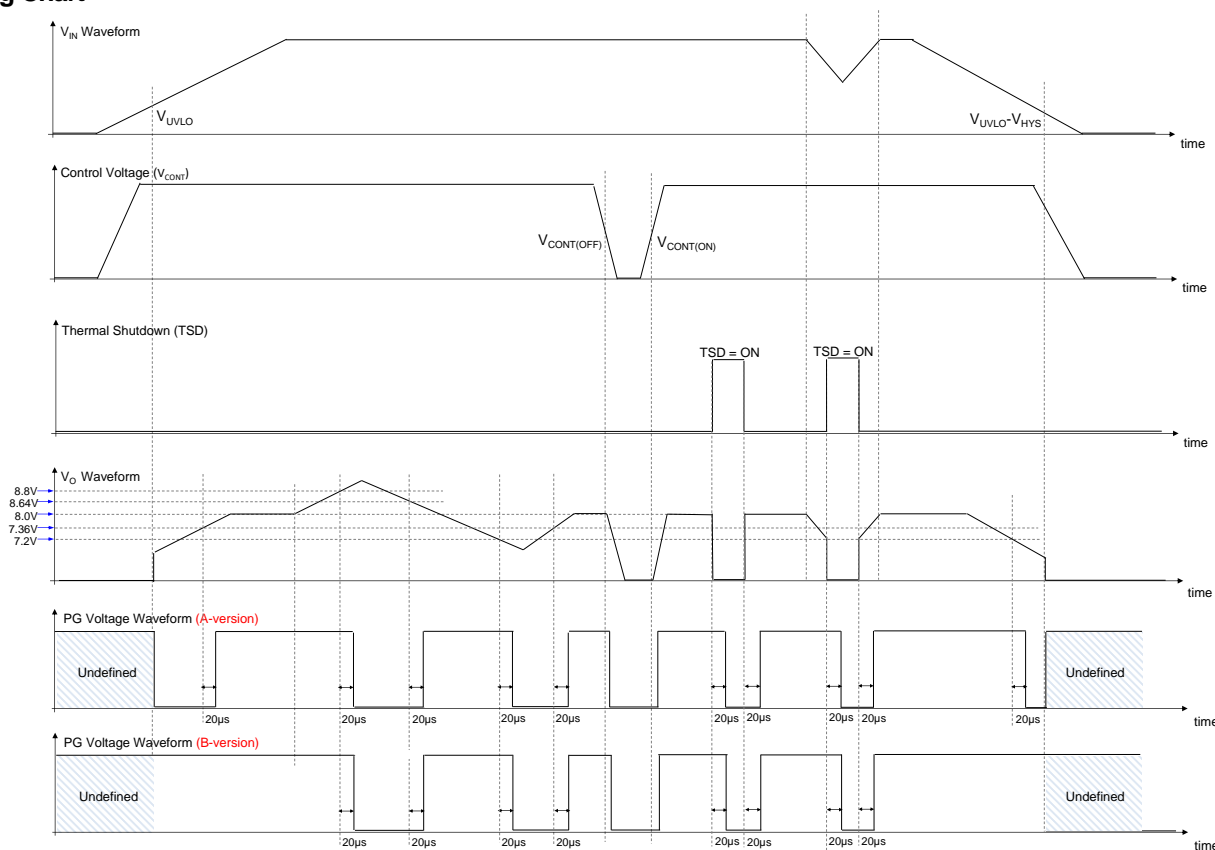

■ REVISION HISTORY

DATE	REVISION	CHANGES
May 19, 2022	Ver.1.0	Initial Release

Nisshinbo Micro Devices Inc.

TO-252-5-L5

PI-TO-252-5-L5-E-A

■ PACKAGE DIMENSIONS

UNIT: mm

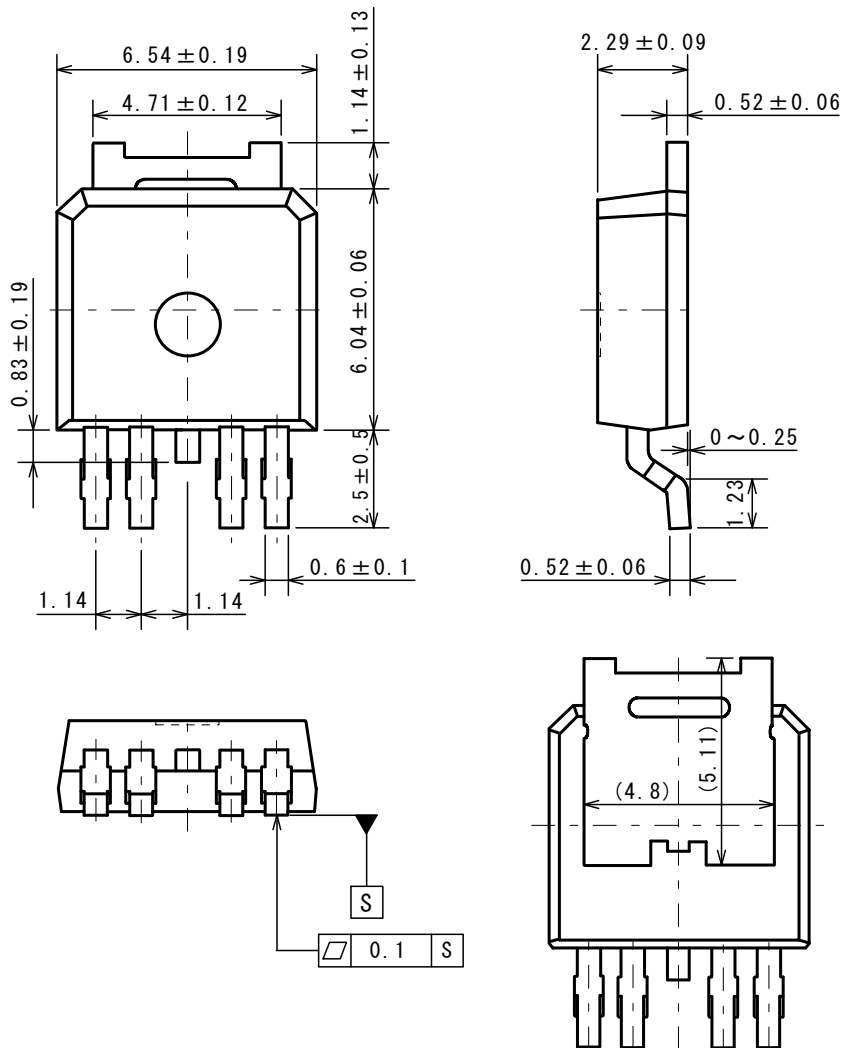

■ EXAMPLE OF SOLDER PADS DIMENSIONS

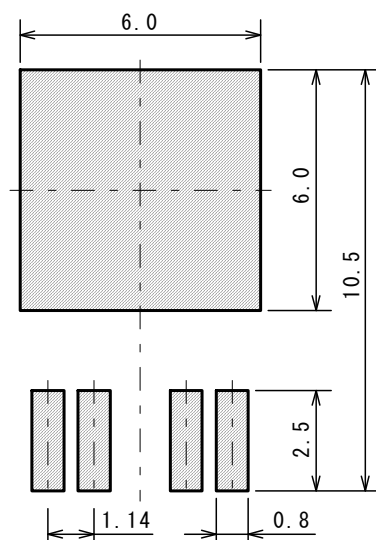

Nisshinbo Micro Devices Inc.

TO-252-5-L5

PI-TO-252-5-L5-E-A

■ PACKING SPEC

UNIT: mm

TAPING DIMENSIONS

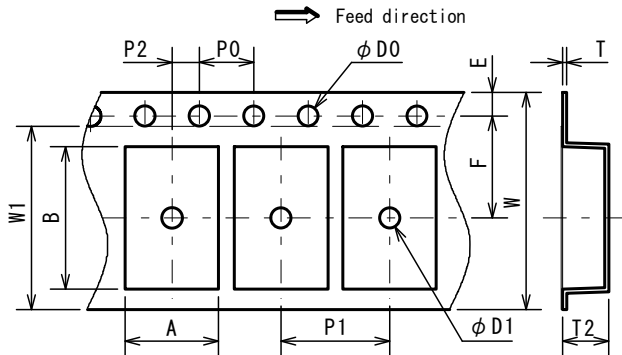

SYMBOL	DIMENSION	REMARKS
A	6.9±0.1	BOTTOM DIMENSION
B	10.5±0.1	BOTTOM DIMENSION
D0	1.5 ^{+0.1} ₀	
D1	1.5 ^{+0.1} ₀	
E	1.75±0.1	
F	7.5±0.1	
P0	4.0±0.1	
P1	8.0±0.1	
P2	2.0±0.1	
T	0.3±0.1	
T2	3.4 max	
W	16.0±0.3	
W1	13.5	THICKNESS 0.1max

REEL DIMENSIONS

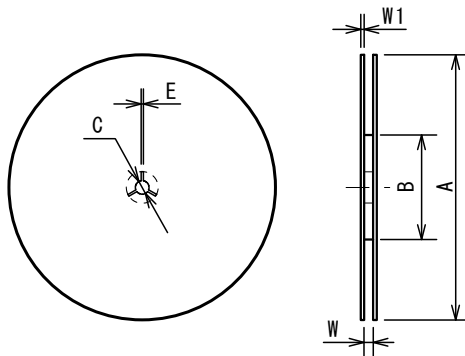

SYMBOL	DIMENSION
A	phi 330±2
B	phi 80±1
C	phi 13±0.5
E	2
W	17.5±0.5
W1	2±0.5

TAPING STATE

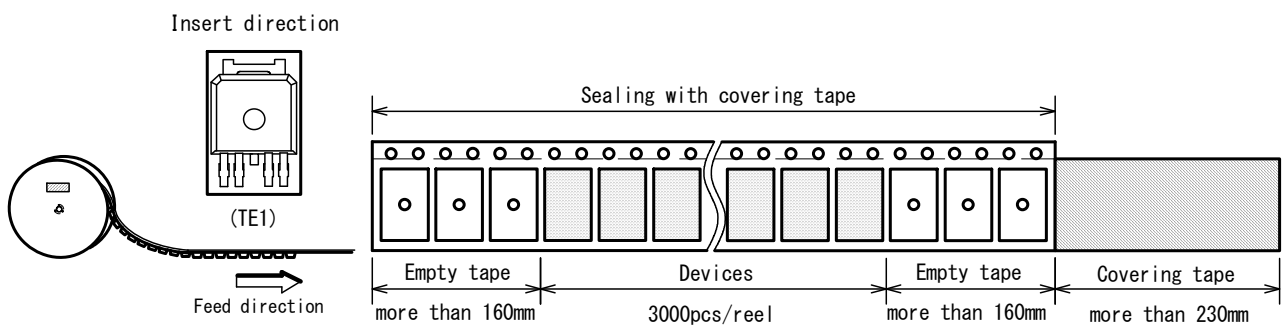

PACKING STATE

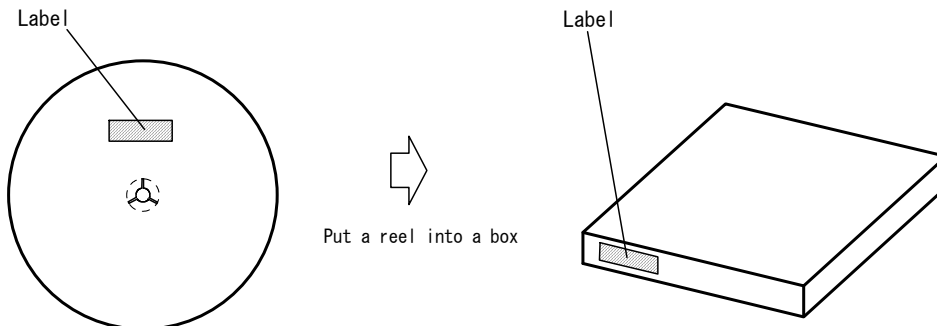

1. The products and the product specifications described in this document are subject to change or discontinuation of production without notice for reasons such as improvement. Therefore, before deciding to use the products, please refer to our sales representatives for the latest information thereon.
2. The materials in this document may not be copied or otherwise reproduced in whole or in part without the prior written consent of us.
3. This product and any technical information relating thereto are subject to complementary export controls (so-called KNOW controls) under the Foreign Exchange and Foreign Trade Law, and related politics ministerial ordinance of the law. (Note that the complementary export controls are inapplicable to any application-specific products, except rockets and pilotless aircraft, that are insusceptible to design or program changes.) Accordingly, when exporting or carrying abroad this product, follow the Foreign Exchange and Foreign Trade Control Law and its related regulations with respect to the complementary export controls.
4. The technical information described in this document shows typical characteristics and example application circuits for the products. The release of such information is not to be construed as a warranty of or a grant of license under our or any third party's intellectual property rights or any other rights.
5. The products listed in this document are intended and designed for use as general electronic components in standard applications (office equipment, telecommunication equipment, measuring instruments, consumer electronic products, amusement equipment etc.). Those customers intending to use a product in an application requiring extreme quality and reliability, for example, in a highly specific application where the failure or misoperation of the product could result in human injury or death should first contact us.
 - Aerospace Equipment
 - Equipment Used in the Deep Sea
 - Power Generator Control Equipment (nuclear, steam, hydraulic, etc.)
 - Life Maintenance Medical Equipment
 - Fire Alarms / Intruder Detectors
 - Vehicle Control Equipment (automotive, airplane, railroad, ship, etc.)
 - Various Safety Devices
 - Traffic control system
 - Combustion equipment

In case your company desires to use this product for any applications other than general electronic equipment mentioned above, make sure to contact our company in advance. Note that the important requirements mentioned in this section are not applicable to cases where operation requirements such as application conditions are confirmed by our company in writing after consultation with your company.

6. We are making our continuous effort to improve the quality and reliability of our products, but semiconductor products are likely to fail with certain probability. In order to prevent any injury to persons or damages to property resulting from such failure, customers should be careful enough to incorporate safety measures in their design, such as redundancy feature, fire containment feature and fail-safe feature. We do not assume any liability or responsibility for any loss or damage arising from misuse or inappropriate use of the products.
7. The products have been designed and tested to function within controlled environmental conditions. Do not use products under conditions that deviate from methods or applications specified in this datasheet. Failure to employ the products in the proper applications can lead to deterioration, destruction or failure of the products. We shall not be responsible for any bodily injury, fires or accident, property damage or any consequential damages resulting from misuse or misapplication of the products.
8. **Quality Warranty**
 - 8-1. **Quality Warranty Period**

In the case of a product purchased through an authorized distributor or directly from us, the warranty period for this product shall be one (1) year after delivery to your company. For defective products that occurred during this period, we will take the quality warranty measures described in section 8-2. However, if there is an agreement on the warranty period in the basic transaction agreement, quality assurance agreement, delivery specifications, etc., it shall be followed.
 - 8-2. **Quality Warranty Remedies**

When it has been proved defective due to manufacturing factors as a result of defect analysis by us, we will either deliver a substitute for the defective product or refund the purchase price of the defective product.

Note that such delivery or refund is sole and exclusive remedies to your company for the defective product.
 - 8-3. **Remedies after Quality Warranty Period**

With respect to any defect of this product found after the quality warranty period, the defect will be analyzed by us. On the basis of the defect analysis results, the scope and amounts of damage shall be determined by mutual agreement of both parties. Then we will deal with upper limit in Section 8-2. This provision is not intended to limit any legal rights of your company.
9. Anti-radiation design is not implemented in the products described in this document.
10. The X-ray exposure can influence functions and characteristics of the products. Confirm the product functions and characteristics in the evaluation stage.
11. WLCSP products should be used in light shielded environments. The light exposure can influence functions and characteristics of the products under operation or storage.
12. Warning for handling Gallium and Arsenic (GaAs) products (Applying to GaAs MMIC, Photo Reflector). These products use Gallium (Ga) and Arsenic (As) which are specified as poisonous chemicals by law. For the prevention of a hazard, do not burn, destroy, or process chemically to make them as gas or power. When the product is disposed of, please follow the related regulation and do not mix this with general industrial waste or household waste.
13. Please contact our sales representatives should you have any questions or comments concerning the products or the technical information.



Nisshinbo Micro Devices Inc.

Official website

<https://www.nisshinbo-microdevices.co.jp/en/>

Purchase information

<https://www.nisshinbo-microdevices.co.jp/en/buy/>