

LOW DROPOUT VOLTAGE REGULATOR

■ GENERAL DESCRIPTION

The NJU7780/81 is a low dropout voltage regulator with ON/OFF Control.

Advanced CMOS technology achieves low quiescent current. It is suitable for battery operating applications.

NJU7781 features shunt switch which improves turn off response of output voltage when ON/OFF control is used.

■ PACKAGE OUTLINE

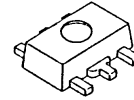

NJU7780/81U1

■ FEATURES

- High Ripple Rejection 65dB typ. (f=400Hz, $V_o=3V$)
- Low quiescent Current $I_q=20\mu A$ ($I_o=0mA$, $V_{CONT}=V_{IN}$)
- Output capacitor with 1.0 μF ceramic capacitor
- Output Current $I_o(max)=300mA$
- High Precision Output $V_o\pm 1.0\%$
- Low Dropout Voltage 0.15V typ. ($I_o=150mA$, $V_o=3.0V$)
- ON/OFF Control (Active High)
- Shunt Switch Only NJU7781
- Internal Over Current Protection
- Internal Thermal Overload Protection
- CMOS technology
- Package outline SOT-89-5

■ PIN CONFIGURATION

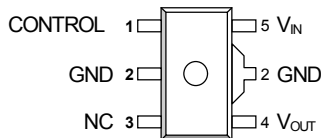

■ BLOCK DIAGRAM

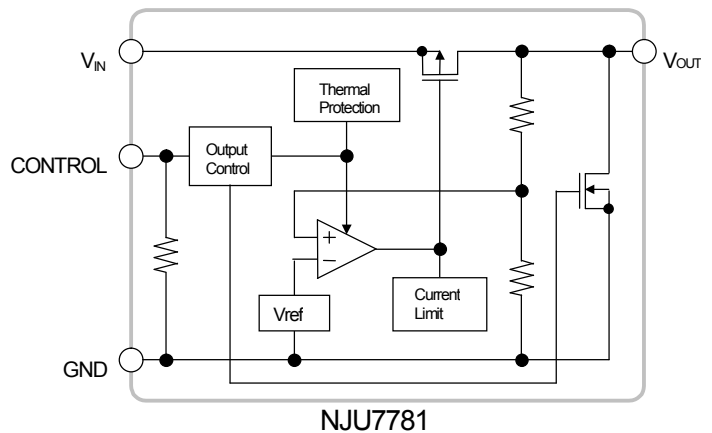
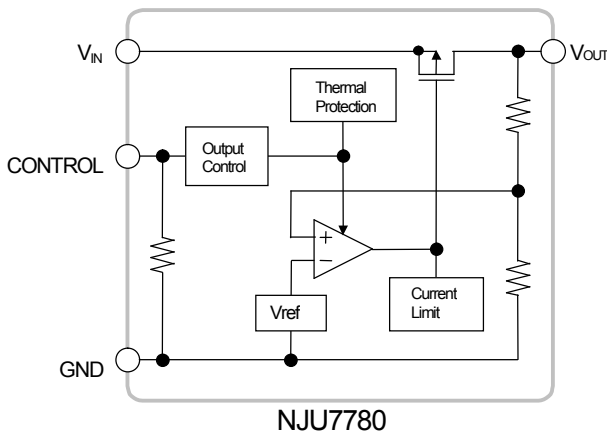

NJU7780/81

■ OUTPUT VOLTAGE RANK LIST

Device Name	V _{OUT}	Device Name	V _{OUT}	Device Name	V _{OUT}
NJU778xU1-15	1.5V	NJU778xU1-28	2.8V	NJU778xU1-04	4.0V
NJU778xU1-18	1.8V	NJU778xU1-29	2.9V	NJU778xU1-05	5.0V
NJU778xU1-21	2.1V	NJU778xU1-03	3.0V		
NJU778xU1-25	2.5V	NJU778xU1-33	3.3V		

■ ABSOLUTE MAXIMUM RATINGS

(Ta=25°C)

PARAMETER	SYMBOL	RATINGS	UNIT
Input Voltage	V _{IN}	+10	V
Control Voltage	V _{CONT}	+10(*1)	V
Power Dissipation	P _D	350(*2)	mW
		500(*3)	
		765(*4)	
Operating Temperature	T _{opr}	-40 ~ +85	°C
Storage Temperature	T _{stg}	-40 ~ +125	°C
OFF-state Output Sink Current (*5)	I _o	10	mA

(*1): When input voltage is less than +10V, the absolute maximum control voltage is equal to the input voltage.

(*2): Device itself.

(*3): Mounted on glass epoxy board. (76.2 × 114.3 × 1.6mm:based on EIA/JDEC standard size, 2Layers, Cu area 100mm²)

(*4): Mounted on glass epoxy board. (76.2 × 114.3 × 1.6mm:based on EIA/JDEC standard, 4Layers)

(For 4Layers: Applying 74.2 × 74.2mm inner Cu area and a thermal via hole to a board based on JEDEC standard JESD51-5)

(*5): This maximum rating is applied to NJU7781.

■ Input Voltage Range

V_{IN}=+2.3 ~ +9V (In case of Vo<2.1V version)

■ ELECTRICAL CHARACTERISTICS

($V_{IN}=V_O+1V$, $C_{IN}=0.1\mu F$, $C_O=0.1\mu F$, $T_a=25^\circ C$)

PARAMETER	SYMBOL	TEST CONDITION	MIN.	TYP.	MAX.	UNIT	
Output Voltage	V_O	$I_O=30mA$	-1.0%	-	+1.0%	V	
Input Voltage	V_{IN}		-	-	9	V	
Quiescent Current	I_Q	$I_O=0mA$, $V_{CONT}=V_{IN}$	-	20	40	μA	
Quiescent Current at Control OFF	$I_{Q(OFF)}$	$V_{CONT}=0V$	-	-	1	μA	
Output Current	I_O	$V_O - 0.1V(V_O < 2.1V)$ $V_O - 0.3V(V_O \geq 2.1V)$	300	-	-	mA	
Short Current Limit	I_{LIM}	$V_O=0V$	-	120	-	mA	
Line Regulation	$\Delta V_O/\Delta V_{IN}$	$V_{IN}=V_O+1V \sim V_O+6V(V_O < 3.0)$, $V_{IN}=V_O+1V \sim V_O+9V(V_O \geq 3.0)$, $I_O=30mA$	-	-	0.10	%/V	
Load Regulation	$\Delta V_O/\Delta I_O$	$I_O=0 \sim 300mA$	-	-	0.015	%/mA	
Dropout Voltage(*6)	$\Delta V_{I,O}$	$I_O=150mA$	$2.1 \leq V_O \leq 2.6V$	-	0.18	0.25	V
			$2.7 \leq V_O \leq 3.3V$	-	0.15	0.22	
			$3.4 \leq V_O \leq 5.0V$	-	0.12	0.2	
Ripple Rejection	RR	$e_{in}=200mV_{rms}$, $f=400Hz$, $I_O=10mA$, $V_O=3.0V$	-	65	-	dB	
Average Temperature Coefficient of Output Voltage	$\Delta V_O/\Delta T_a$	$T_a=0 \sim 85^\circ C$, $I_O=10mA$	-	± 100	-	ppm/ $^\circ C$	
Output Noise Voltage	V_{NO}	$f=10Hz \sim 80kHz$, $I_O=10mA$, $V_O=3.0V$	-	80	-	μV_{rms}	
Pull-Down Resistance	R_{CONT}		1.5	5	10	M Ω	
Control Voltage for ON-state	$V_{CONT(ON)}$		1.6	-	-	V	
Control Voltage for OFF-state	$V_{CONT(OFF)}$		-	-	0.3	V	
Pull-down Resistance at OFF-state(*7)	$R_{O(OFF)}$	$V_{CONT}=0V$ ($V_O=3.0V$ Version)	-	190	-	Ω	

(*6): The output voltage excludes under 2.1V.

(*7) This electrical characteristics is applied to NJU7781.

The above specification is a common specification for all output voltages.

Therefore, it may be different from the individual specification for a specific output voltage.

NJU7780/81

■ THERMAL CHARACTERISTICS

PARAMETER	SYMBOL	VALUE	UNIT
Junction-to-ambient thermal resistance	θ_{ja}	200 (*8)	°C/W
		130 (*9)	
Junction-to-Top of package characterization parameter	ψ_{jt}	67 (*8)	°C/W
		65 (*9)	

(*8): Mounted on glass epoxy board. (76.2 × 114.3 × 1.6mm:based on EIA/JDEC standard size, 2Layers, Cu area 100mm²)

(*9): Mounted on glass epoxy board. (76.2 × 114.3 × 1.6mm:based on EIA/JDEC standard, 4Layers)

(For 4Layers: Applying 74.2 × 74.2mm inner Cu area and a thermal via hole to a board based on JEDEC standard JESD51-5)

■ POWER DISSIPATION vs. AMBIENT TEMPERATURE

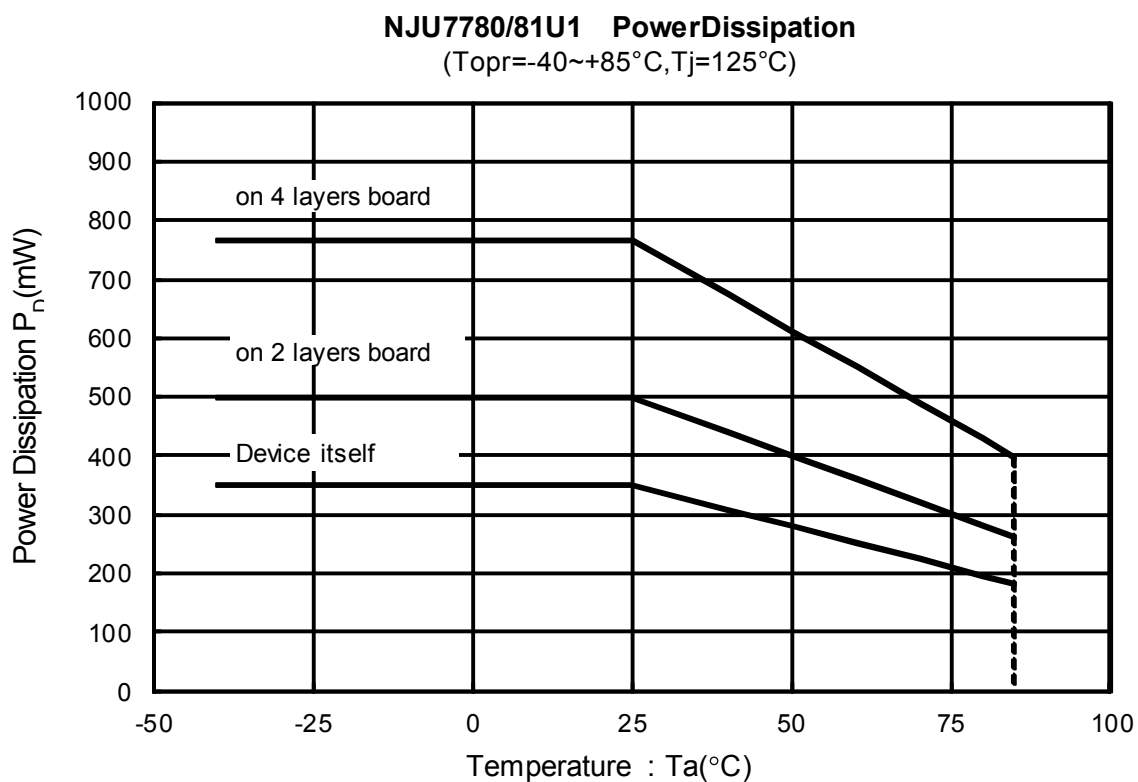

■ TEST CIRCUIT

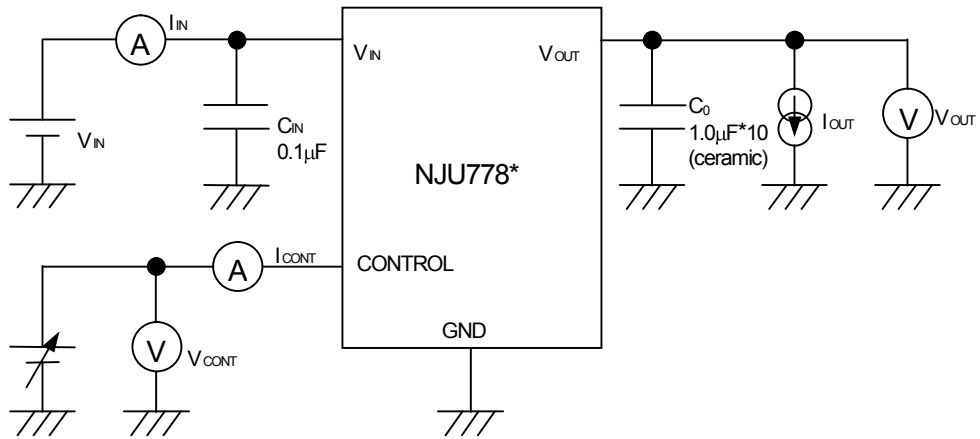

*8 : $V_o \leq 2.0V$ version, $C_o = 2.2\mu F$ (Ceramic)

■ TYPICAL APPLICATION

① In the case where ON/OFF Control is not required:

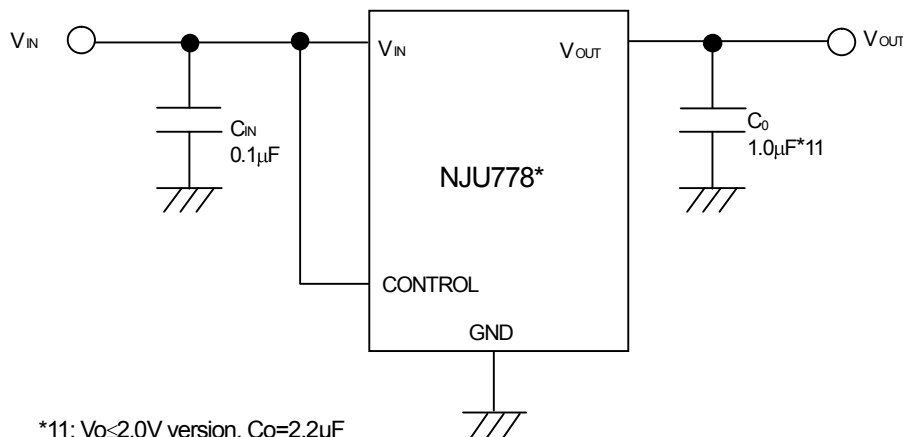

*11: $V_o \leq 2.0V$ version, $C_o = 2.2\mu F$

Connect control pin to V_{IN} pin

② In use of ON/OFF CONTROL:

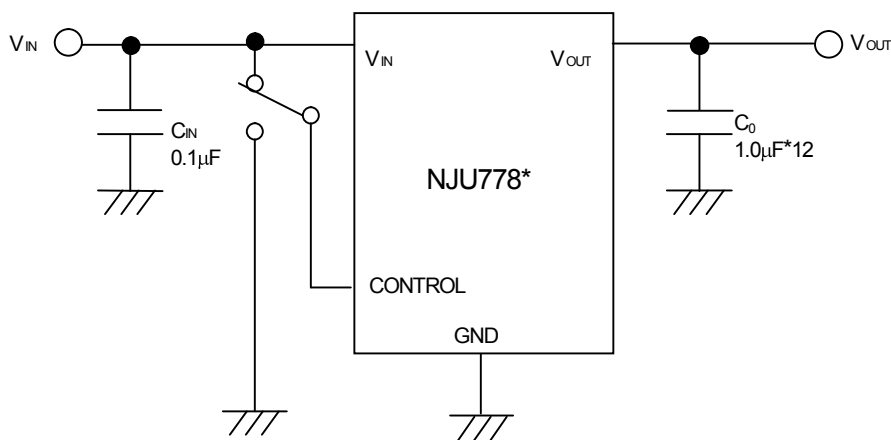

*12 : $V_o \leq 2.0V$ version, $C_o = 2.2\mu F$

State of control pin:

- “H” → output is enabled.
- “L” or “open” → output is disabled.

*Transient response characteristic of Output Voltage

In general, overshoot or undershoot of output voltage may occur due to the transient response characteristic of an internal error amplifier.

Especially, low current consumption regulator may have overshoot or undershoot due to slow feedback caused by current saving design.

Therefore, design validation is important in the following cases:

1. Input voltage or output current change sharply
2. Output capacitors is small
3. Output load is light
4. A regulator starts up with very low dropout voltage operation.

Increasing the value of input and/or output capacitor is a common countermeasure for improving a transient response characteristic.

A transient response characteristic may vary with operating conditions and external components value.

Please check it with the actual environment.

*Input Capacitor C_{IN}

The input capacitor C_{IN} is required to prevent oscillation and reduce power supply ripple for applications when high power supply impedance or a long power supply line.

Therefore, use the recommended C_{IN} value (refer to conditions of ELECTRIC CHARACTERISTIC) or larger and should connect between GND and V_{IN} as shortest path as possible to avoid the problem.

*Output Capacitor C_O

The output capacitor C_O will be required for a phase compensation of the internal error amplifier.

The capacitance and the equivalent series resistance (ESR) influence to stable operation of the regulator.

Use of a smaller C_O may cause excess an output noise or an oscillation of the regulator due to lack of the phase compensation.

On the other hand, use of a larger C_O reduces an output noise and a ripple output, and also improves an output transient response when a load rapidly changes.

Therefore, use the recommended C_O value (refer to conditions of ELECTRIC CHARACTERISTIC) or larger and should connect between GND and V_{OUT} as shortest path as possible for stable operation

The recommended capacitance depends on the output voltage rank. Especially, a low voltage regulator requires larger C_O value.

In addition, you should consider varied characteristics of capacitor (a frequency characteristic, a temperature characteristic, a DC bias characteristic and so on) and unevenness peculiar to a capacitor supplier enough.

When selecting C_O , recommend that have withstand voltage margin against an output voltage and superior temperature characteristics though this product is designed stability works with wide range ESR of capacitor including low ESR products.

ELECTRICAL CHARACTERISTICS

DC CHARACTERISTICS

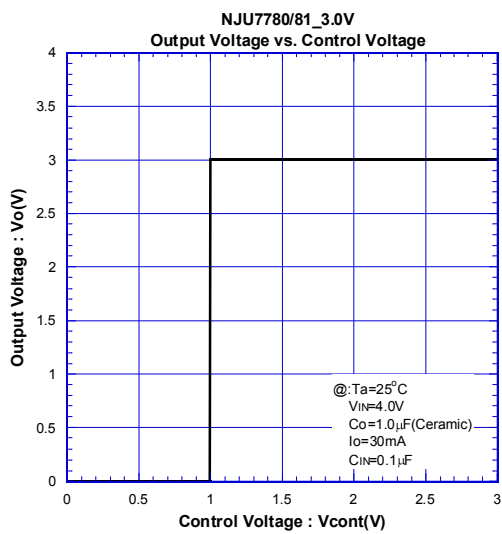
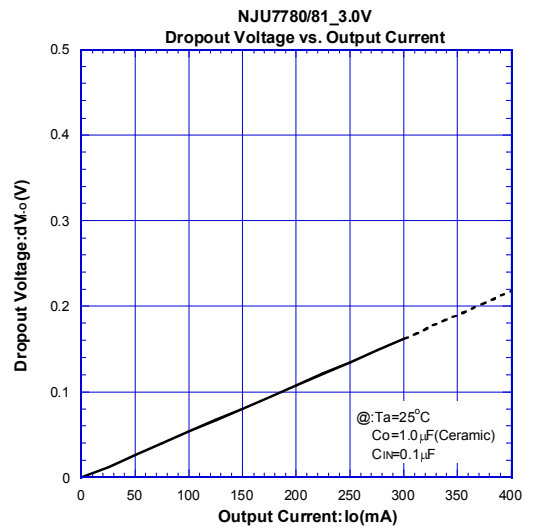
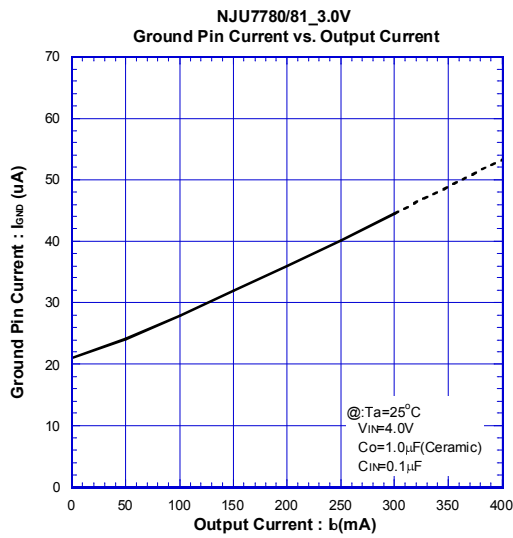
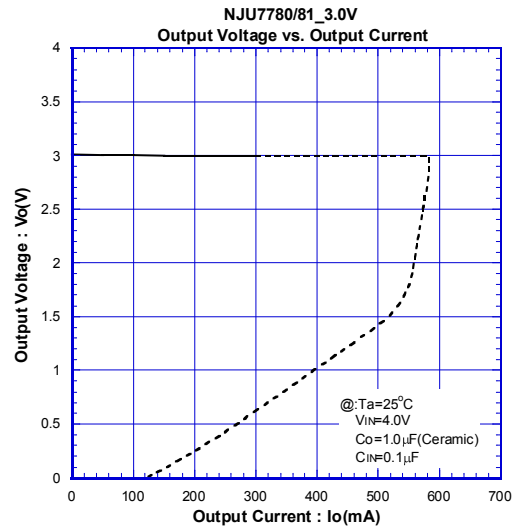
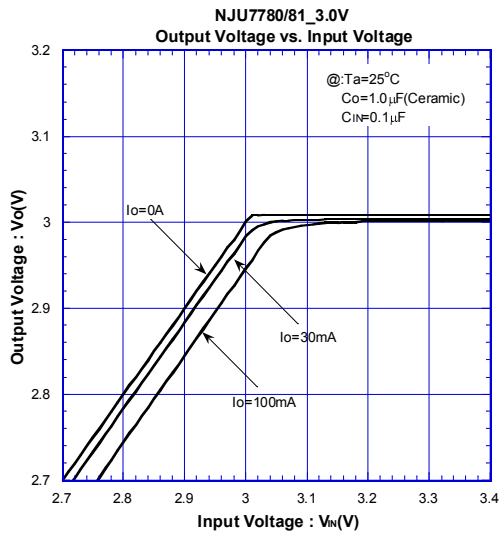

ELECTRICAL CHARACTERISTICS

AC CHARACTERISTICS

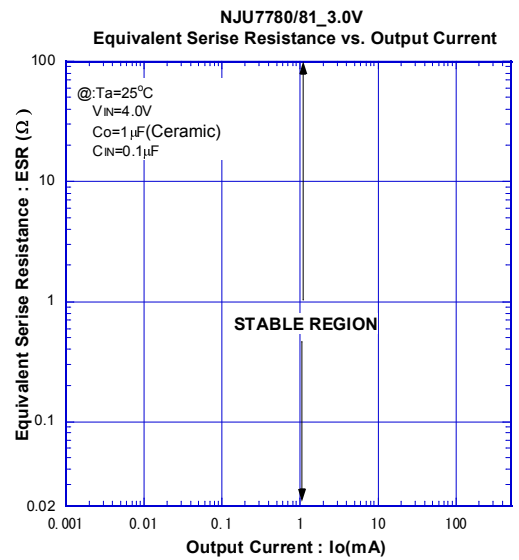
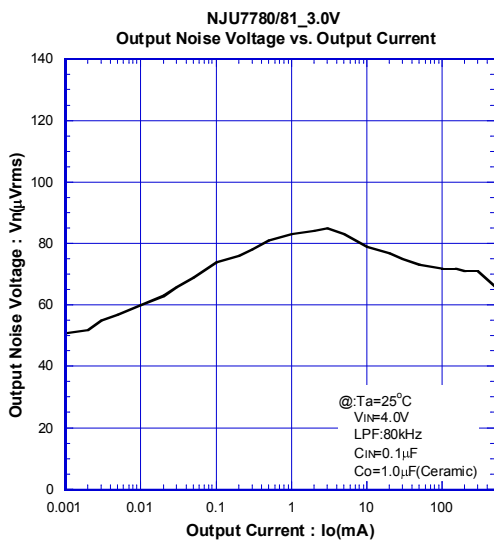
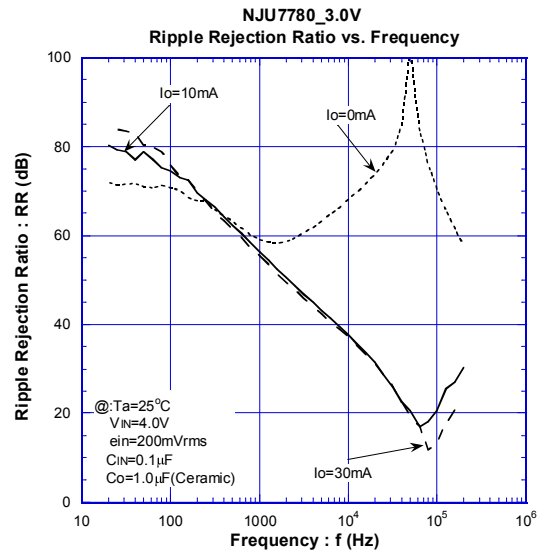
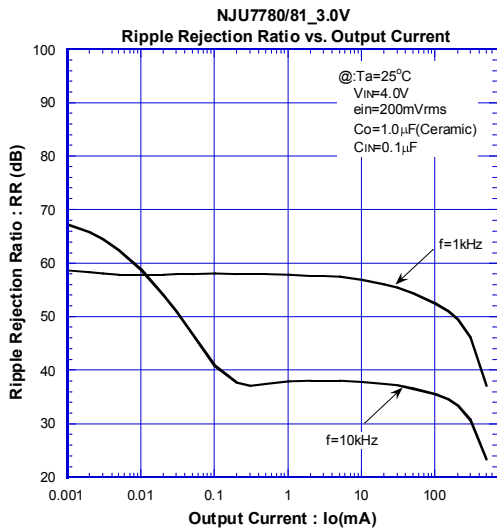

ELECTRICAL CHARACTERISTICS

TEMPERATURE CHARACTERISTICS

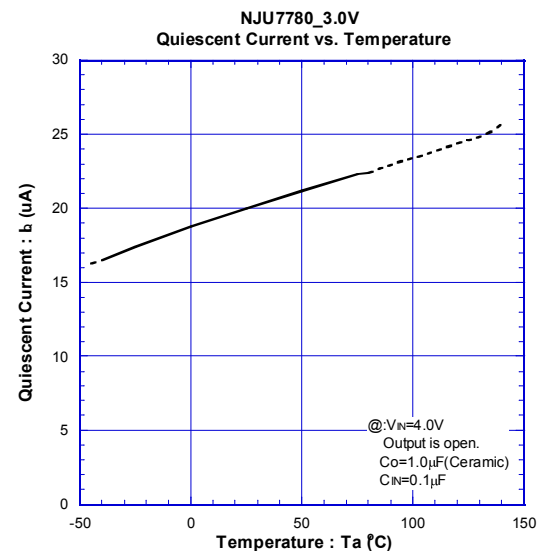
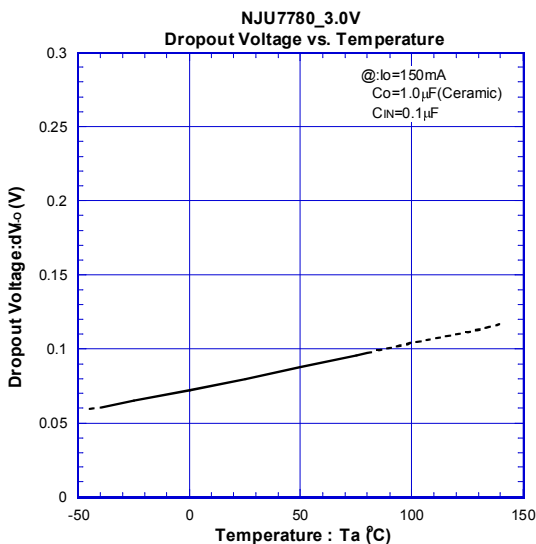
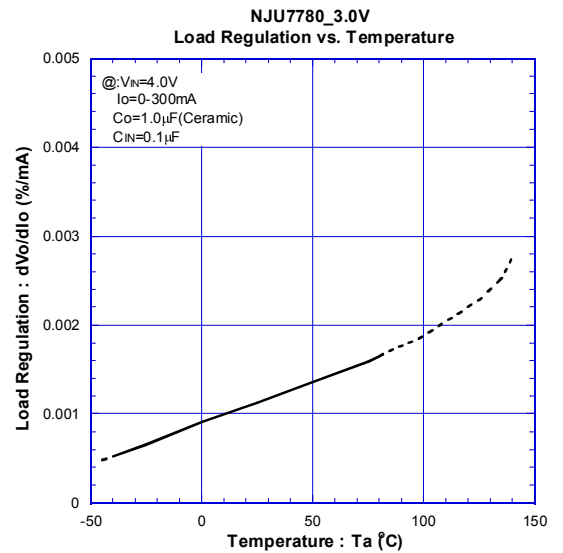
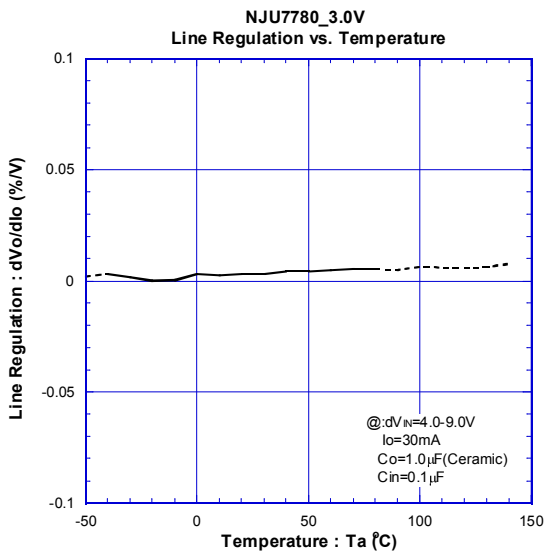
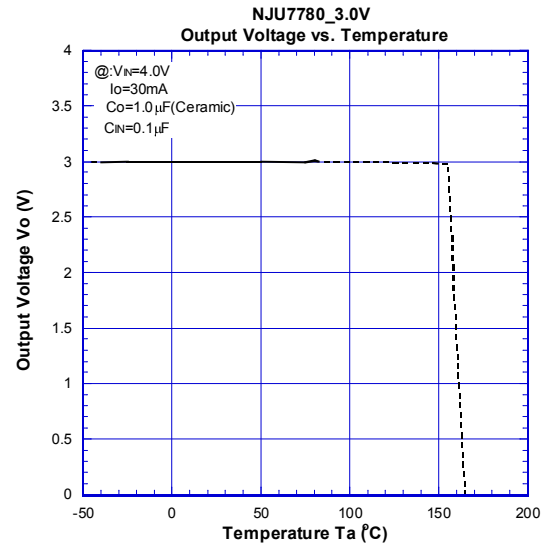
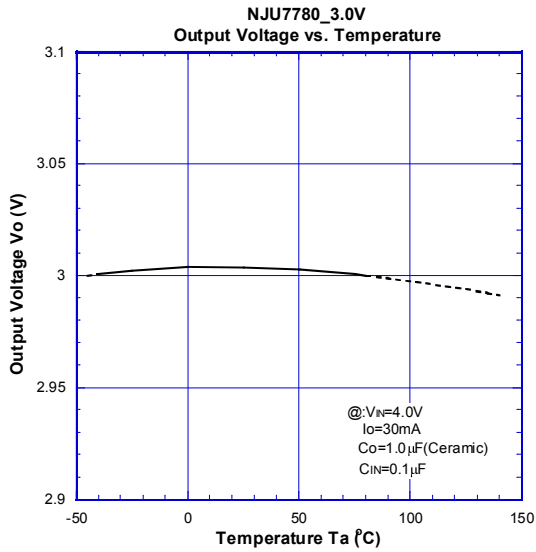

■ ELECTRICAL CHARACTERISTICS

● TEMPERATURE CHARACTERISTICS

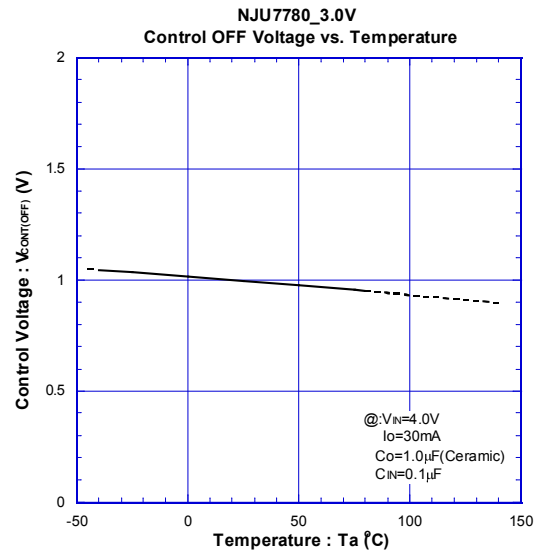
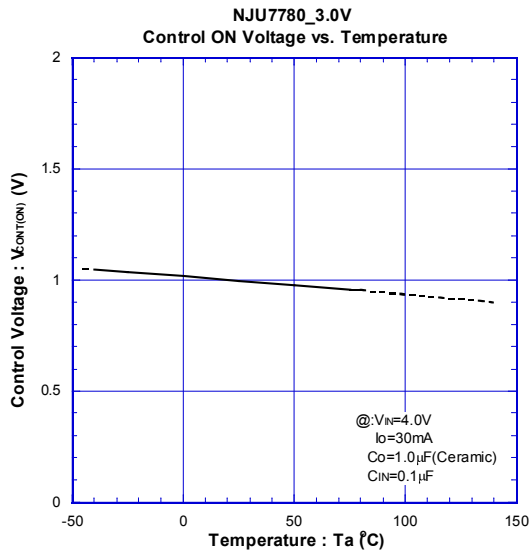

TYPICAL CHARACTERISTICS

TRANSIENT RESPONSE

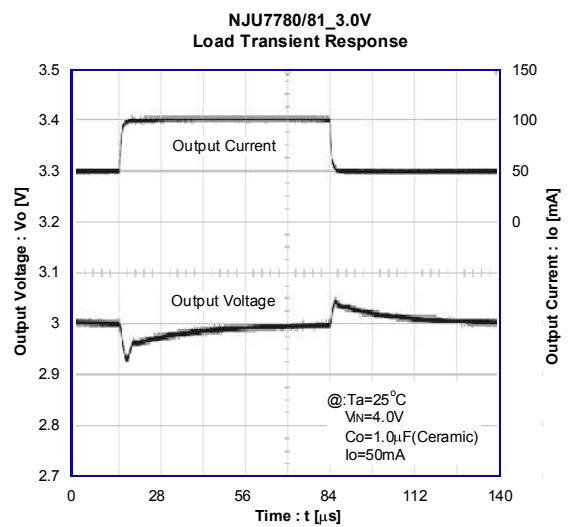
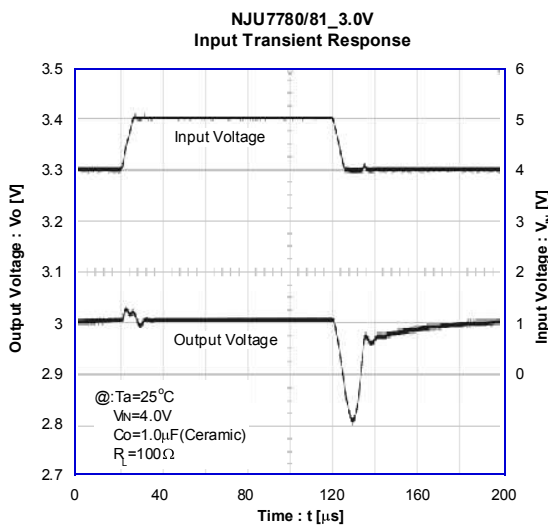
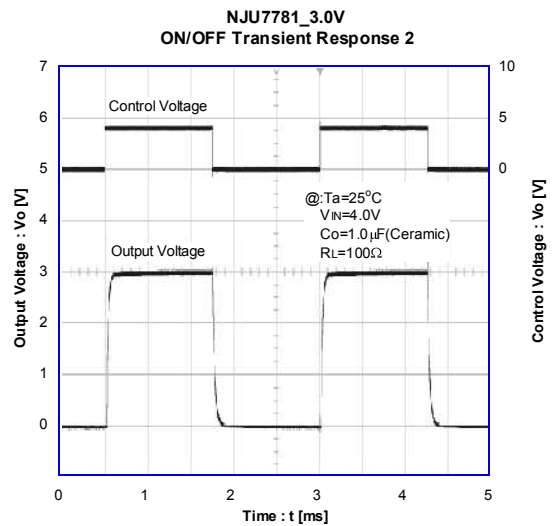
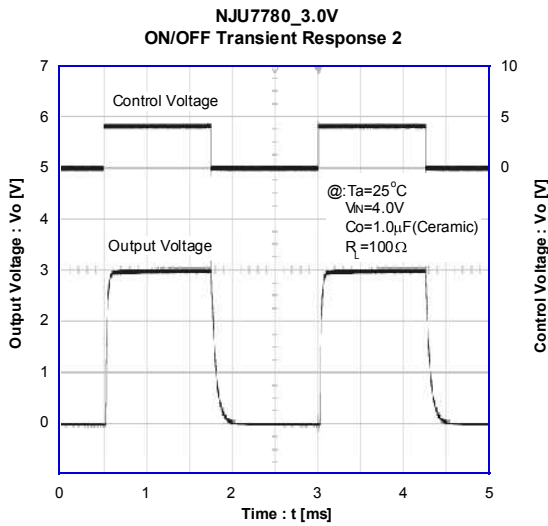
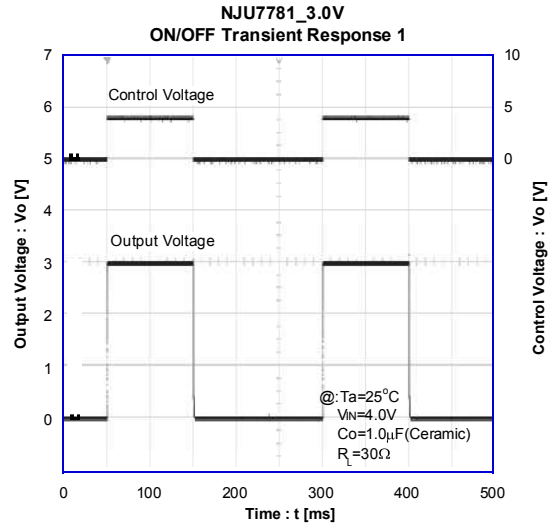
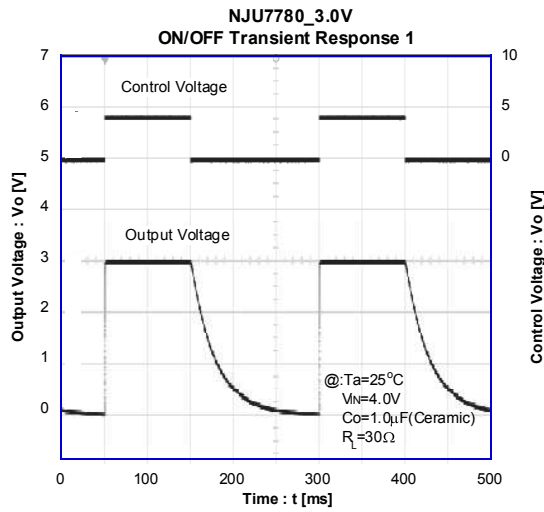

[CAUTION]

The specifications on this databook are only given for information, without any guarantee as regards either mistakes or omissions. The application circuits in this databook are described only to show representative usages of the product and not intended for the guarantee or permission of any right including the industrial rights.