

GNSS LOW NOISE AMPLIFIER

■ GENERAL DESCRIPTION

The NJG1144KA1 is a low noise amplifier GaAs MMIC designed for GNSS (Global Navigation Satellite Systems). This amplifier achieves high gain and a good balance between ultra-low noise figure and excellent VSWR, while low current consumption and high IP3, respectively.

The NJG1144KA1 operates from +1.5V to +3.6V supply voltage range and current consumes is as low as 3.5mA.

Also, the ESD protection circuit is integrated into the IC to achieve high ESD tolerance.

An ultra-small and easy mounting package of FLP6-A1 is adopted.

■ PACKAGE OUTLINE

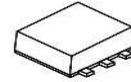

NJG1144KA1

■ APPLICATIONS

GNSS applications, like GPS, Galileo, GLONASS and COMPASS.

■ FEATURES

- Low supply voltage 1.8V/2.85V
- Low current consumption 3.5mA typ. @ $V_{DD}=2.85V$
1.8mA typ. @ $V_{DD}=1.8V$
- High gain 21.0dB typ. @ $f=1575MHz, V_{DD}=2.85V$
- Low noise figure 0.65dB typ. @ $f=1575MHz, V_{DD}=2.85V$
- High Input IP3 -2.0dBm typ. @ $f=1575MHz, V_{DD}=2.85V$
- Small package FLP6-A1 (Package size: 1.6mm x 1.6mm x 0.55mm typ.)
- RoHS compliant and halogen free, MSL1

■ PIN CONFIGURATION

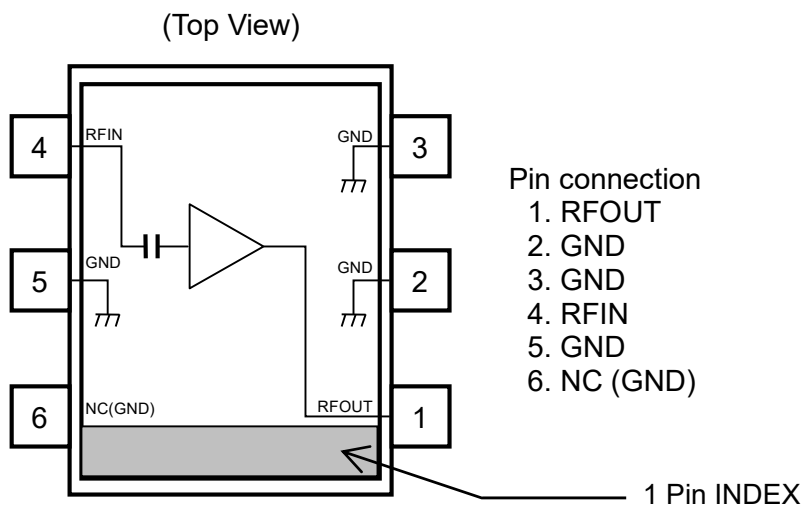

Note: Specifications and description listed in this datasheet are subject to change without notice.

■ ABSOLUTE MAXIMUM RATINGS

$T_a=+25^{\circ}\text{C}$, $Z_s=Z_l=50\Omega$

PARAMETERS	SYMBOL	CONDITIONS	RATINGS	UNITS
Supply voltage	V_{DD}		5.0	V
Input power	P_{IN}	$V_{DD}=2.85\text{V}$	+15	dBm
Power dissipation	P_D	4-layer FR4 PCB with through-hole (74.2mmx74.2mm), $T_j=150^{\circ}\text{C}$	580	mW
Operating temperature	T_{opr}		-40 to +105	$^{\circ}\text{C}$
Storage temperature	T_{stg}		-55 to +150	$^{\circ}\text{C}$

■ ELECTRICAL CHARACTERISTICS 1 (DC CHARACTERISTICS)

General conditions: $V_{DD}=2.85\text{V}$, $T_a=+25^{\circ}\text{C}$

PARAMETER	SYMBOL	CONDITIONS	MIN	TYP	MAX	UNIT
Supply voltage	V_{DD}		1.5	-	3.6	V
Supply current 1	I_{DD1}	RF OFF, $V_{DD}=2.85\text{V}$	-	3.5	5.5	mA
Supply current 2	I_{DD2}	RF OFF, $V_{DD}=1.8\text{V}$	-	1.8	3.2	mA

■ ELECTRICAL CHARACTERISTICS 2 (RF CHARACTERISTICS)

General conditions: $V_{DD}=2.85V$, $f_{RF}=1.575GHz$, $T_a=+25^{\circ}C$, $Z_s=Z_l=50\Omega$, with application circuit

PARAMETER	SYMBOL	CONDITIONS	MIN	TYP	MAX	UNIT
Small signal gain	Gain1		18.0	21.0	23.5	dB
Noise figure	NF1	Exclude PCB, Connector Losses(0.08dB)	-	0.65	0.95	dB
Input power at 1dB gain compression point 1	P-1dB(IN)1		-19.0	-16.5	-	dBm
Input 3rd order intercept point 1	IIP3_1	$f1=f_{RF}$, $f2=f1+100kHz$, $P_{in}=-34dBm$	-5.0	-2.0	-	dBm
RF input VSWR 1	VSWRi1		-	1.5	2.0	-
RF output VSWR 1	VSWRo1		-	1.5	2.0	-

■ ELECTRICAL CHARACTERISTICS 2 (RF CHARACTERISTICS)

General conditions: $V_{DD}=1.8V$, $f_{RF}=1.575GHz$, $T_a=+25^{\circ}C$, $Z_s=Z_l=50\Omega$, with application circuit

PARAMETER	SYMBOL	CONDITIONS	MIN	TYP	MAX	UNIT
Small signal gain 2	Gain2		-	18.0	-	dB
Noise figure 2	NF2	Exclude PCB, Connector Losses(0.08dB)	-	0.85	-	dB
Input power at 1dB gain compression point 2	P-1dB(IN)2		-	-18.5	-	dBm
Input 3rd order intercept point 2	IIP3_2	$f1=f_{RF}$, $f2=f1+100kHz$, $P_{in}=-34dBm$	-	-6.0	-	dBm
RF input VSWR 2	VSWRi2		-	1.8	-	-
RF output VSWR 2	VSWRo2		-	1.8	-	-

■ TERMINAL INFORMATION

No.	SYMBOL	DESCRIPTION
1	RFOUT	RF output and voltage supply terminal.
2	GND	Ground terminal (0V), Connect to the PCB ground plane.
3	GND	Ground terminal (0V), Connect to the PCB ground plane.
4	RFIN	RF input terminal. DC blocking capacitor is not required. An external matching circuit is required.
5	GND	Ground terminal (0V), Connect to the PCB ground plane.
6	NC(GND)	No connected terminal. This terminal is not connected with internal circuit. Please connect to the PCB ground Plane.

■ ELECTRICAL CHARACTERISTICS ($V_{DD}=2.85V$)

(Conditions: $T_a=+25^{\circ}C$, $V_{DD}=2.85V$, $Z_s=Z_l=50\Omega$, with application circuit.)

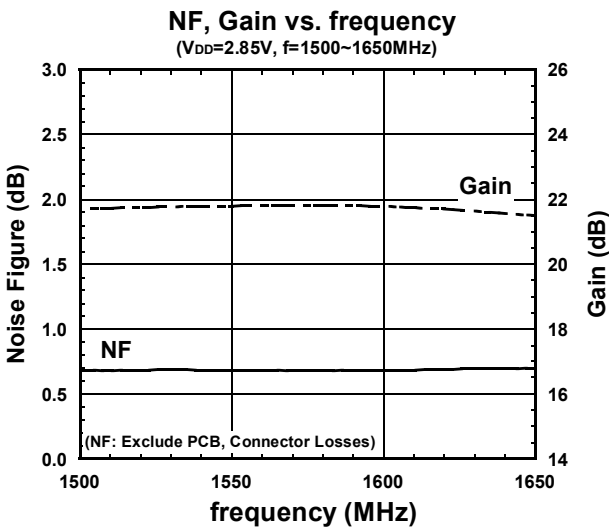
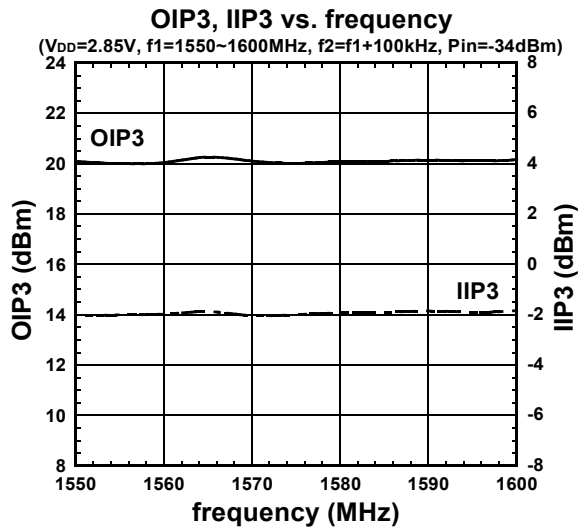
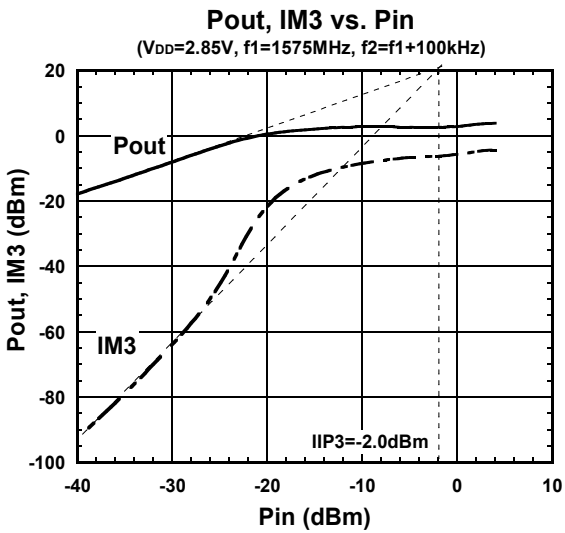
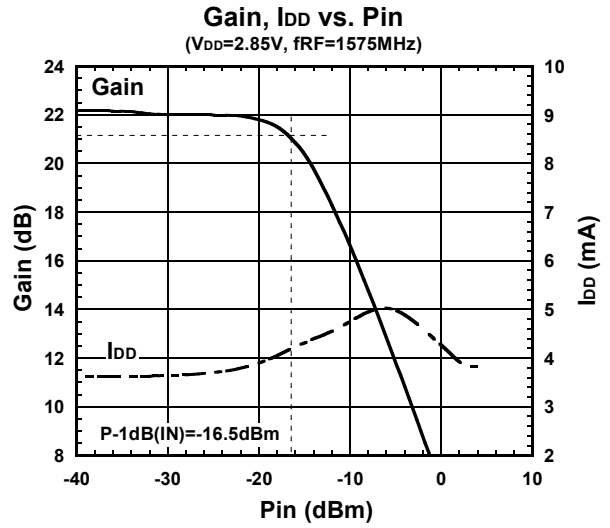
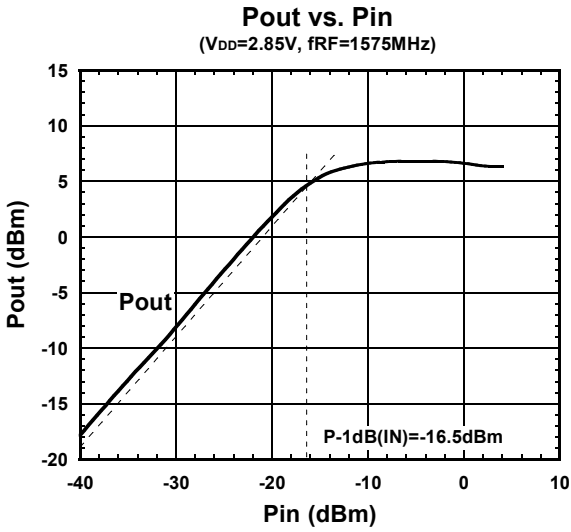

■ ELECTRICAL CHARACTERISTICS (V_{DD} = 2.85V)

(Conditions: V_{DD}=2.85V, Z_S=Z_L=50Ω, with application circuit.)

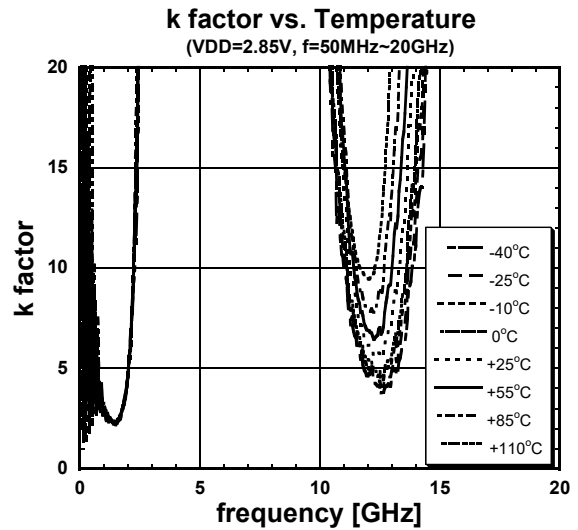
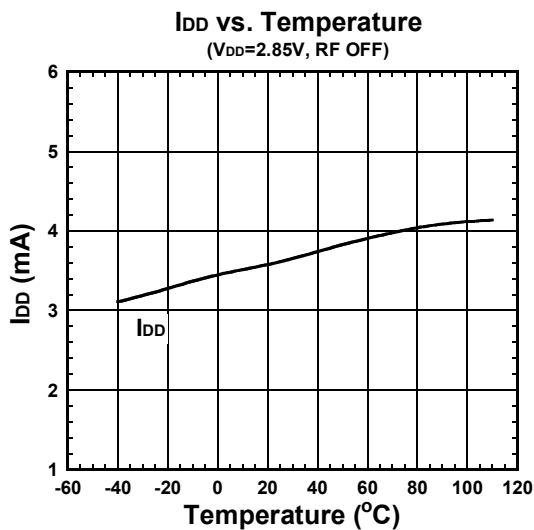
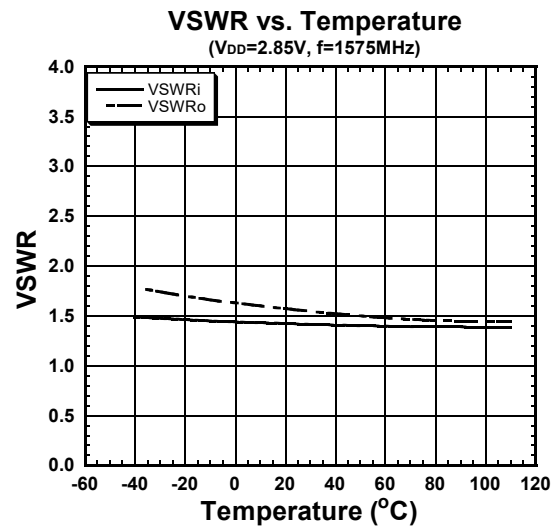
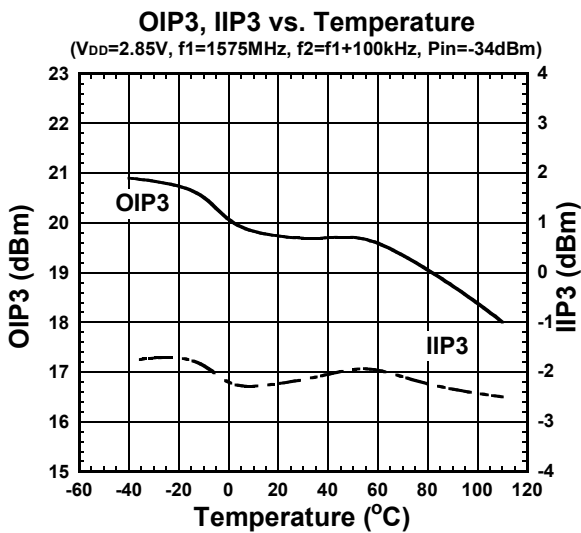
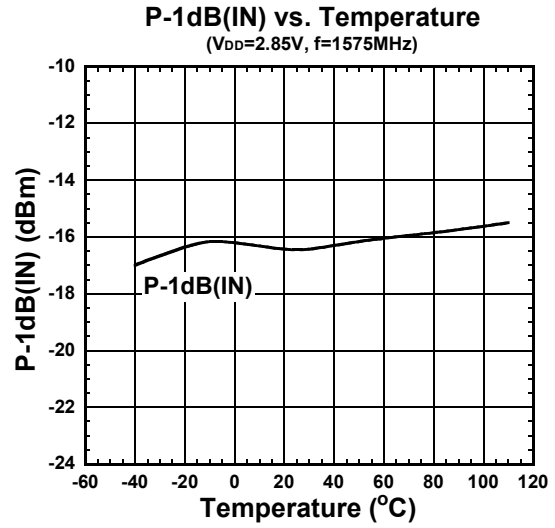
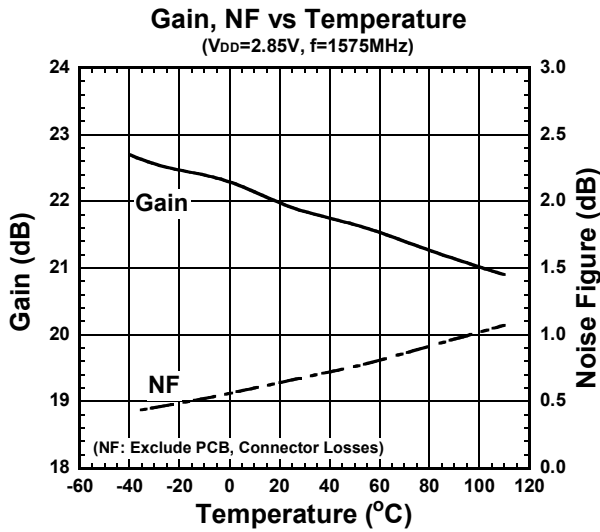

■ ELECTRICAL CHARACTERISTICS (V_{DD} = 1.8V)

(Conditions: Ta = +25°C, V_{DD} = 1.8V, Z_s = Z_l = 50Ω, with application circuit.)

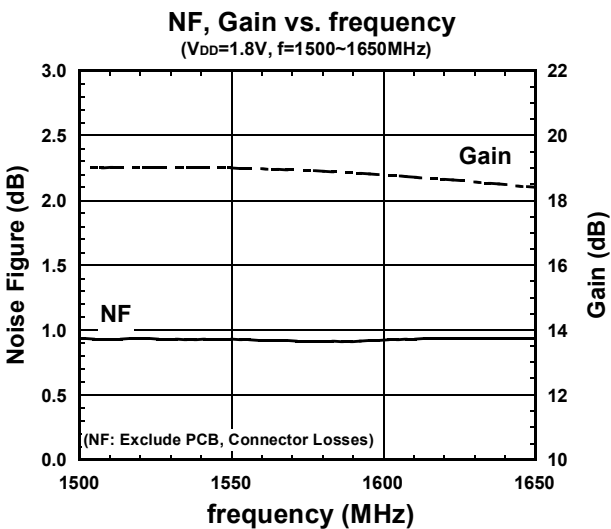
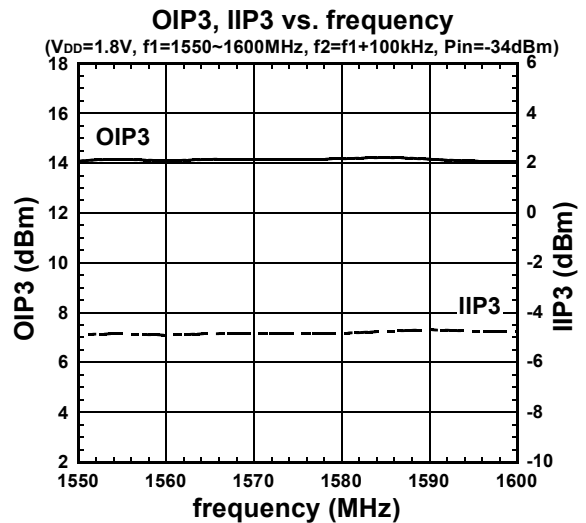
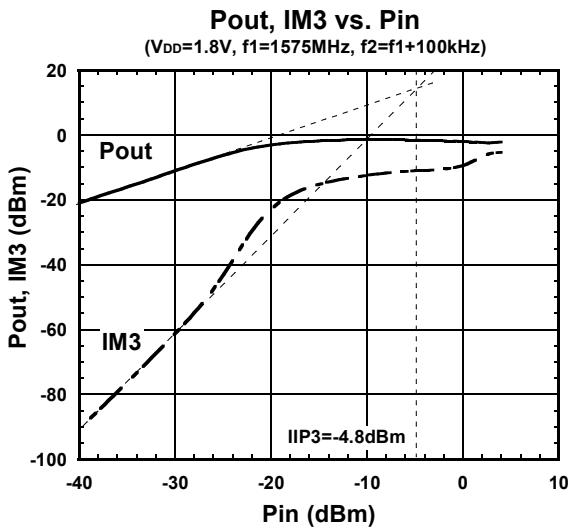
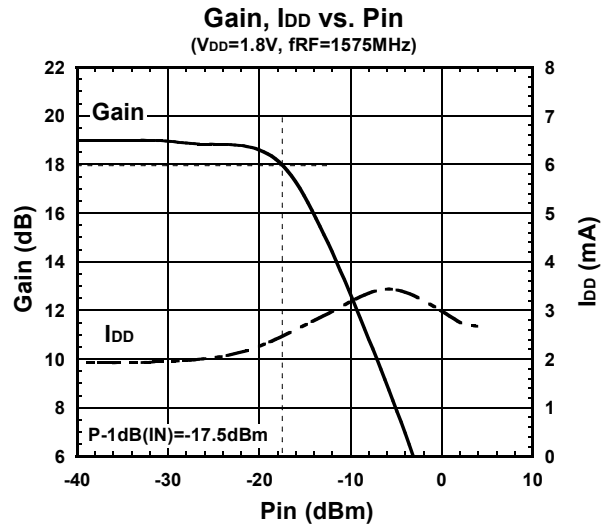
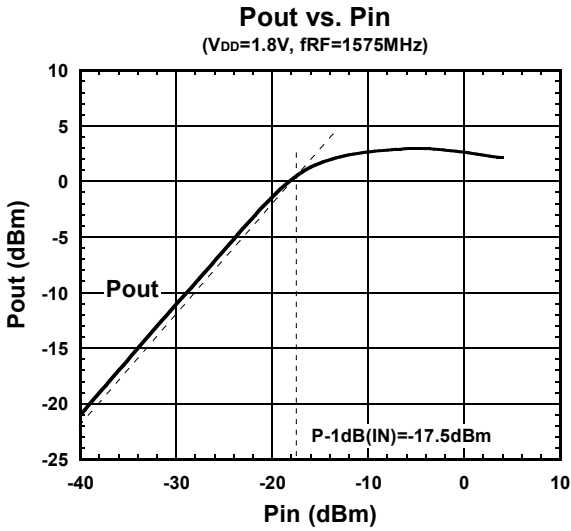

■ ELECTRICAL CHARACTERISTICS (V_{DD} = 1.8V)

(Conditions: V_{DD}=1.8V, Z_s=Z_l=50Ω, with application circuit.)

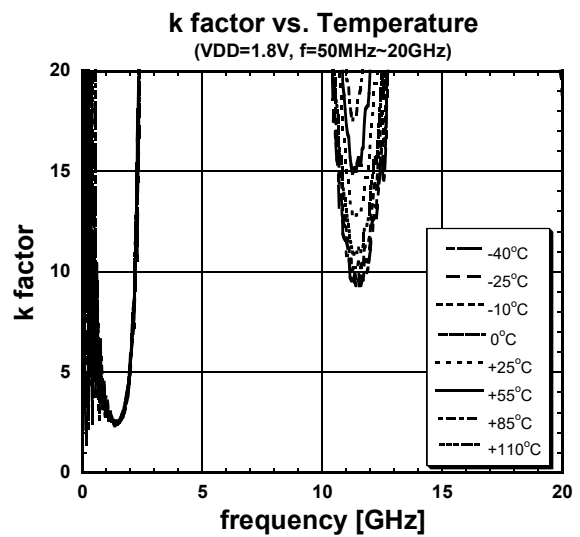
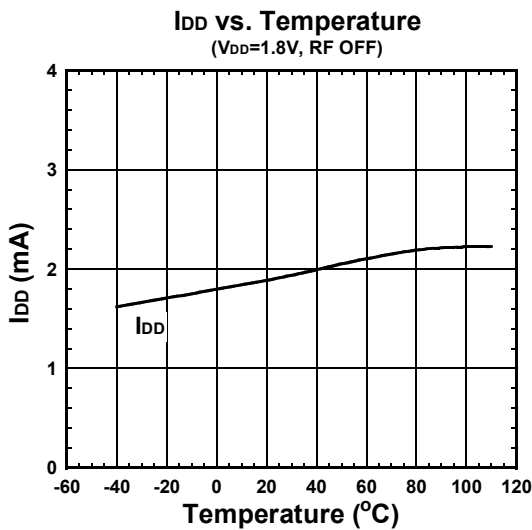
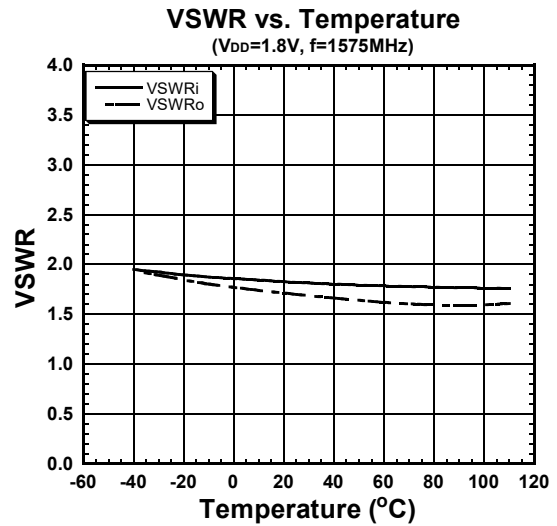
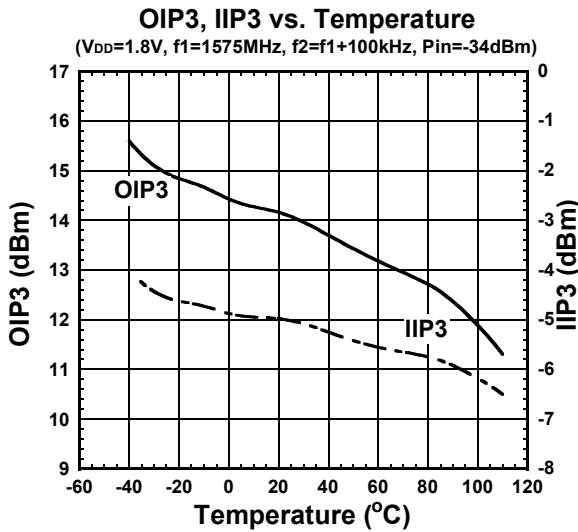
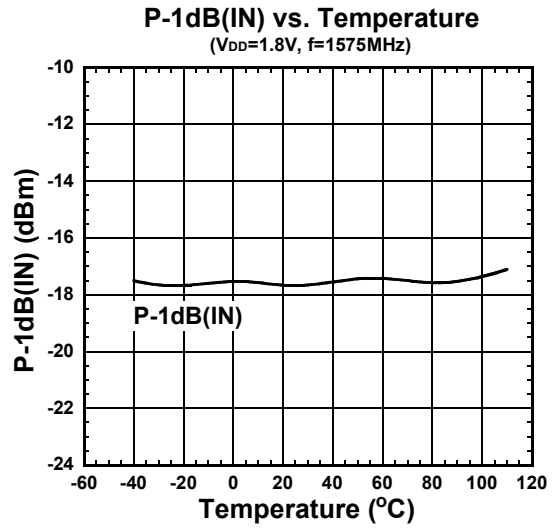
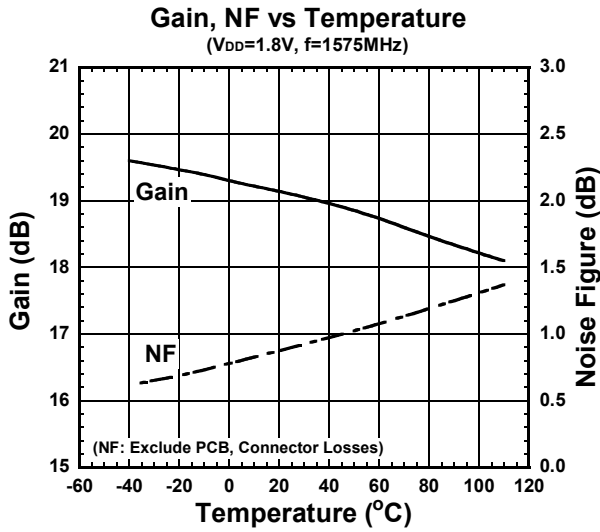

ELECTRICAL CHARACTERISTICS

(Conditions: $T_a=+25^\circ\text{C}$, $Z_s=Z_l=50\Omega$, with application circuit.)

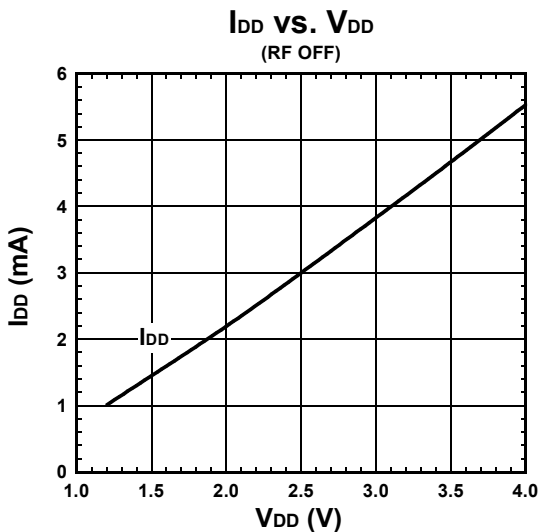
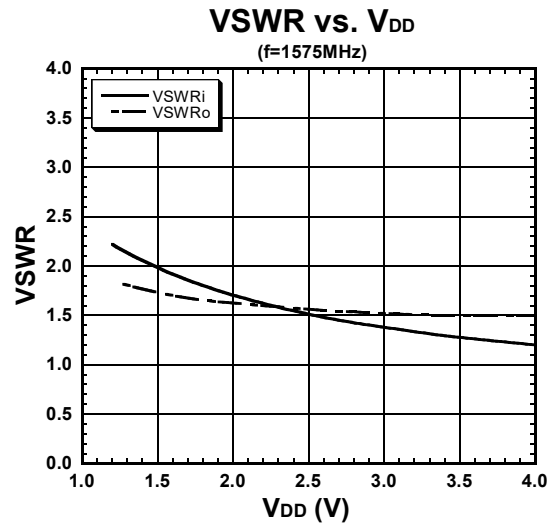
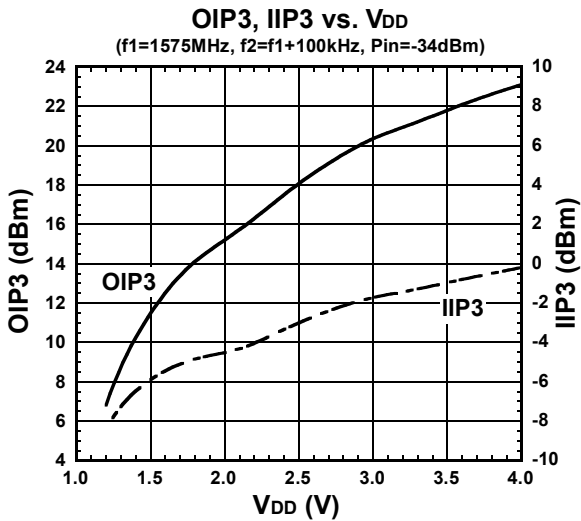
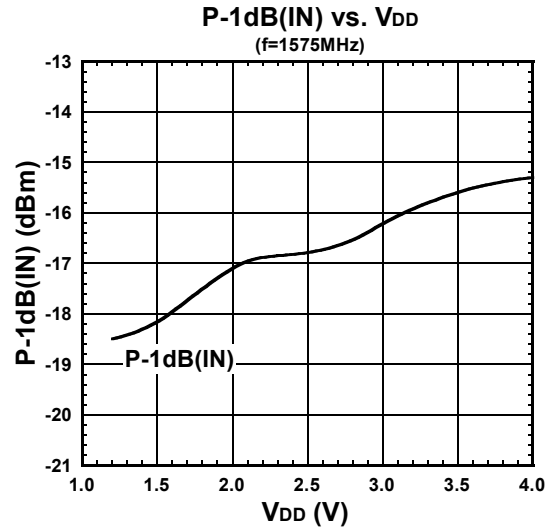
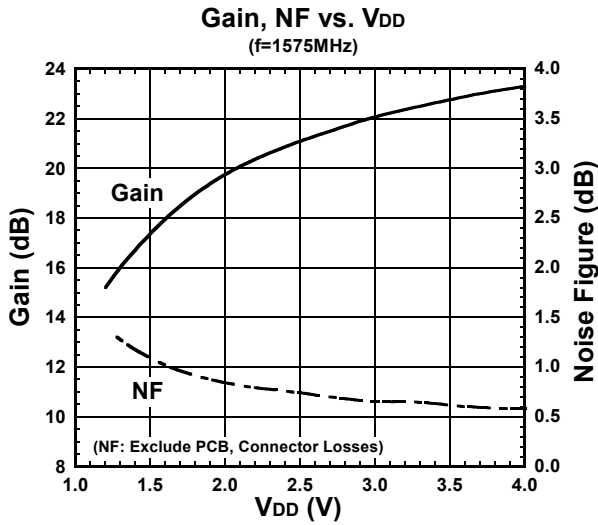

■ ELECTRICAL CHARACTERISTICS ($V_{DD} = 2.85V$)

(Conditions: $T_a = +25^\circ C$, $V_{DD} = 2.85V$, $Z_s = Z_l = 50\Omega$, with application circuit.)

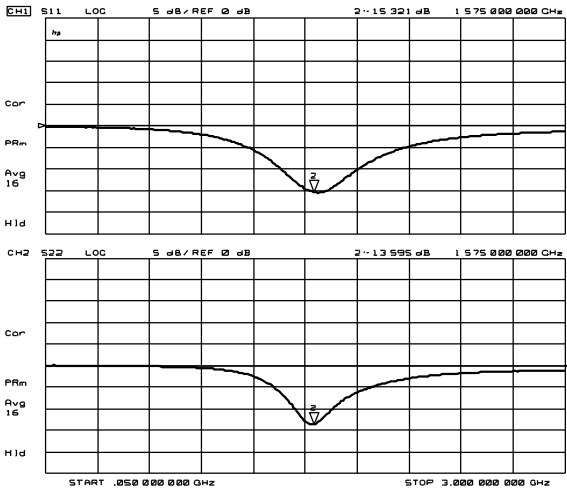

VSWR

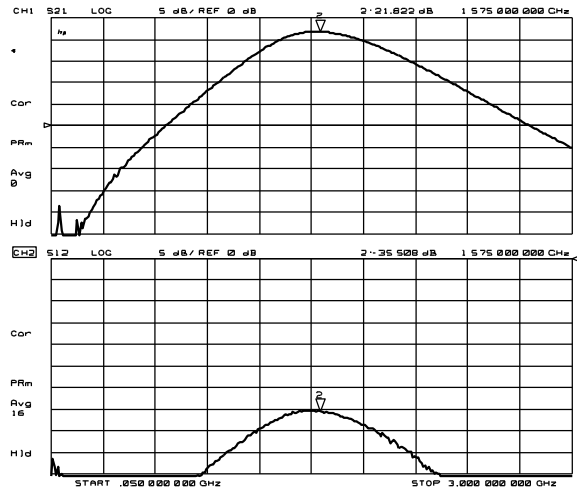

S21, S12

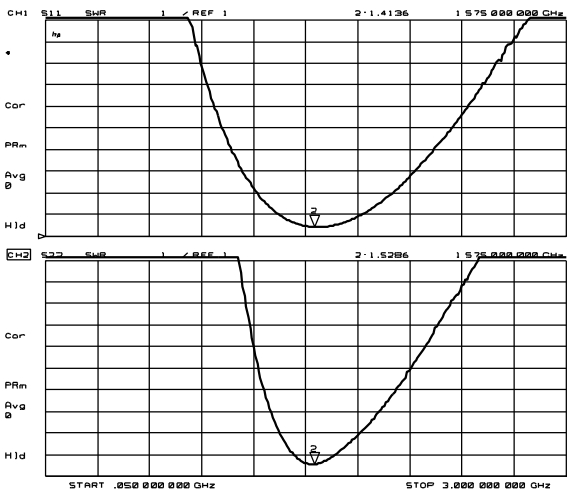

S11, S22

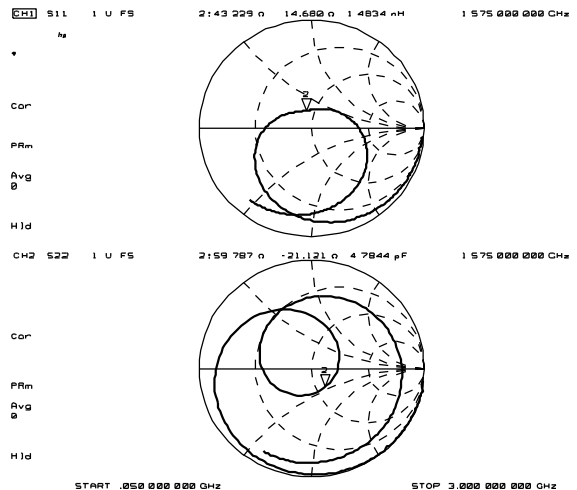

Zin, Zout

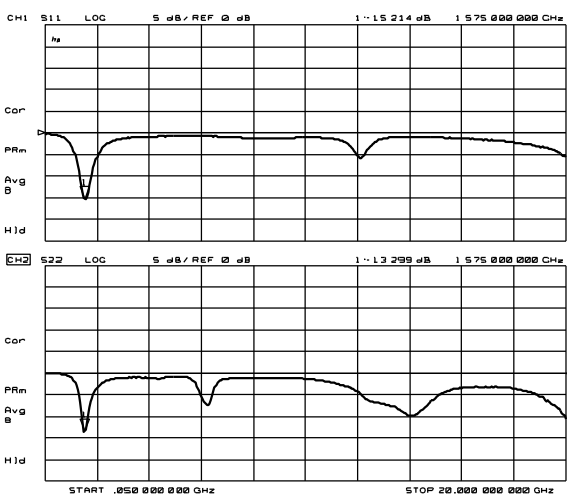

S11, S22 (50MHz to 20GHz)

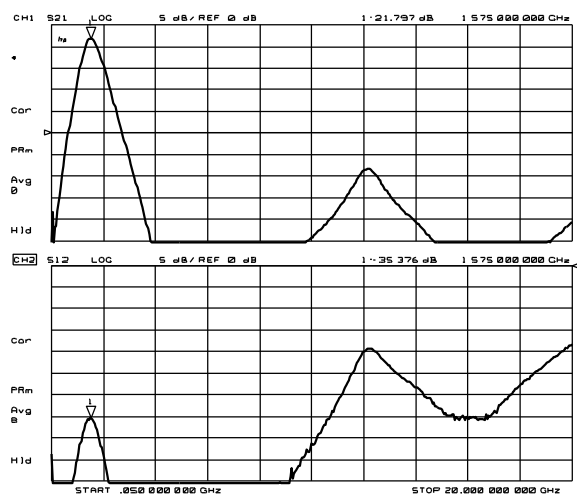

S21, S12 (50MHz to 20GHz)

ELECTRICAL CHARACTERISTICS ($V_{DD} = 1.8V$)

(Conditions: $T_a = +25^\circ C$, $V_{DD} = 1.8V$, $Z_s = Z_l = 50\Omega$, with application circuit.)

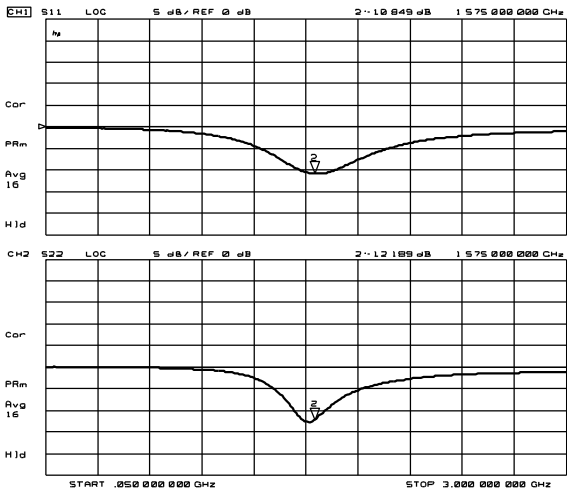

VSWR

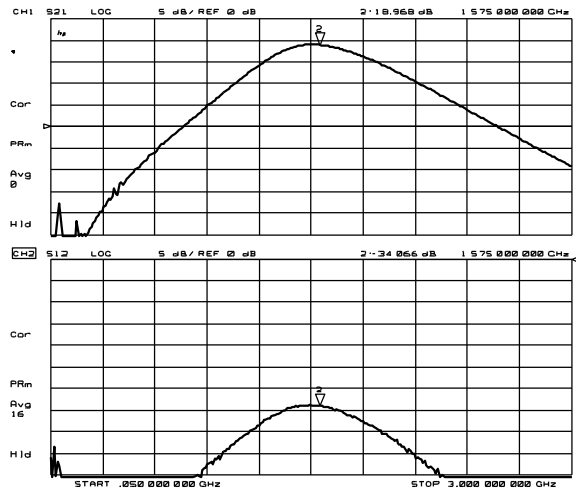

S21, S12

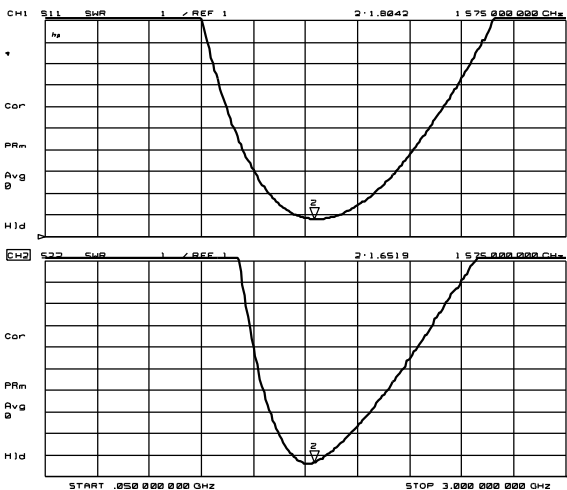

S11, S22

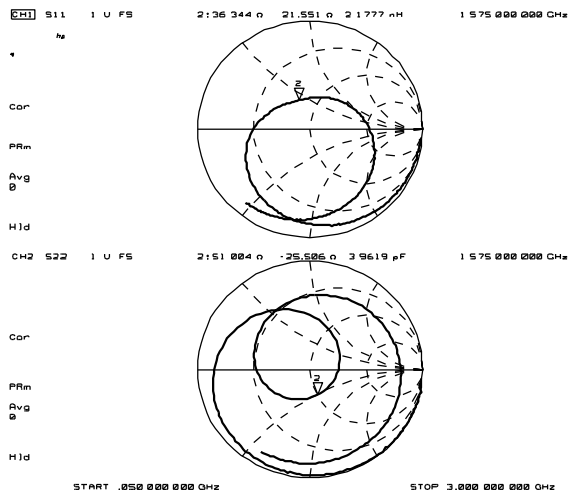

Zin, Zout

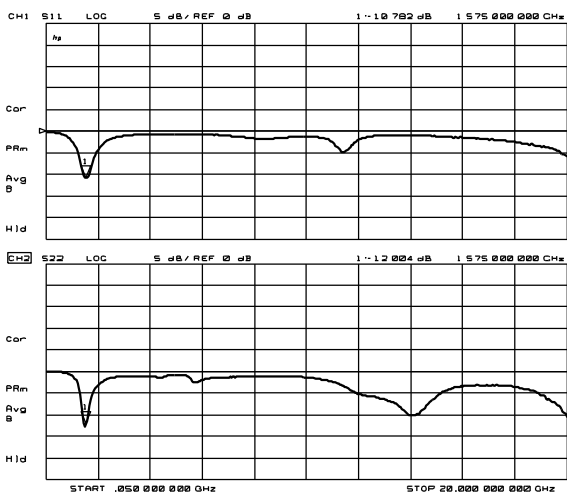

S11, S22 (50MHz to 20GHz)

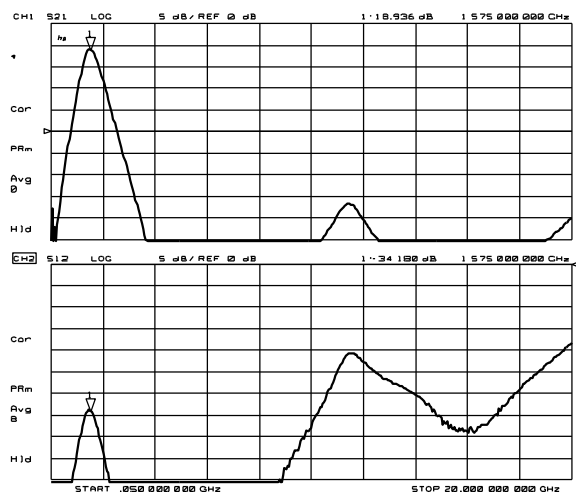

S21, S12 (50MHz to 20GHz)

APPLICATION CIRCUIT

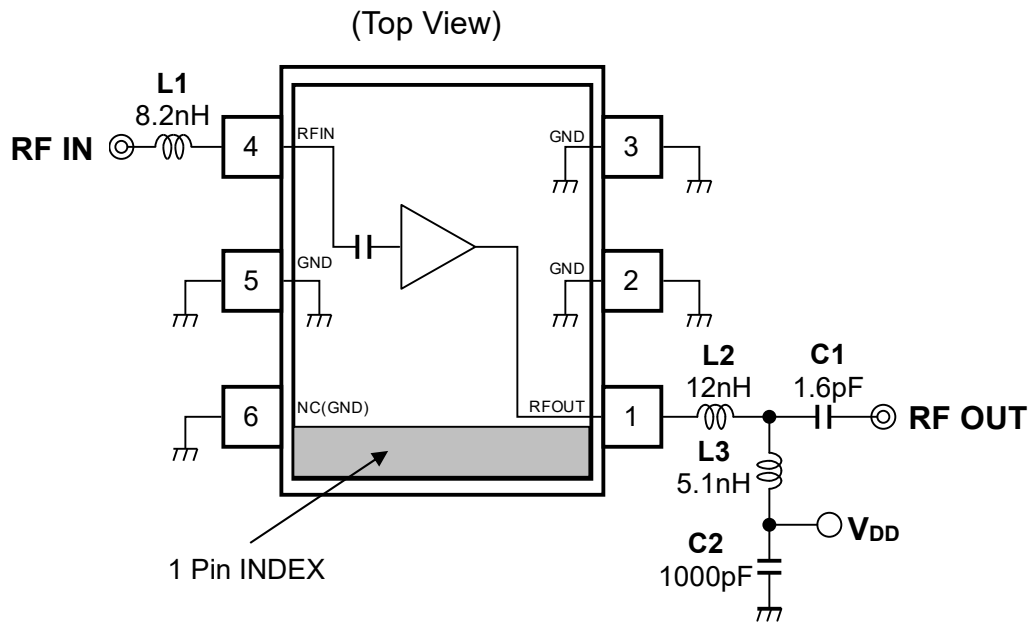

TEST PCB LAYOUT

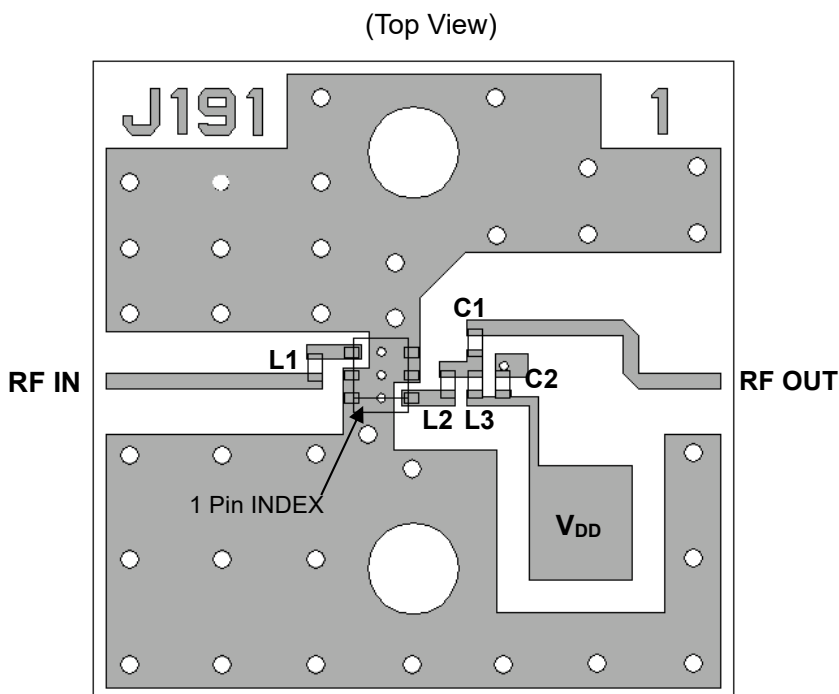

Parts list:

Parts ID	Comments
L1 to L3	MURATA LQP03T_02 Series
C1, C2	MURATA GRM03 Series

PCB (FR-4):
 t=0.2mm
 MICROSTRIP LINE WIDTH
 =0.34mm ($Z_0=50\Omega$)
 PCB SIZE=14.0mm x 14.0mm

Caution:

In order not to couple with terminal RFIN and RFOUT, please layout ground pattern under the IC.

MEASUREMENT BLOCK DIAGRAM

- S parameter Measurements

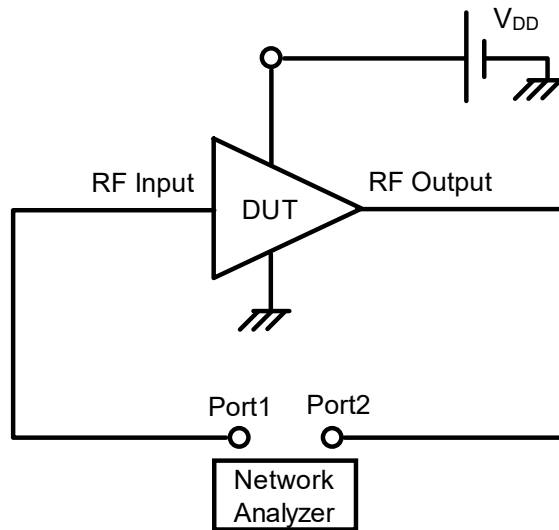

S parameter Measurement Block Diagram

- IIP3 Measurements

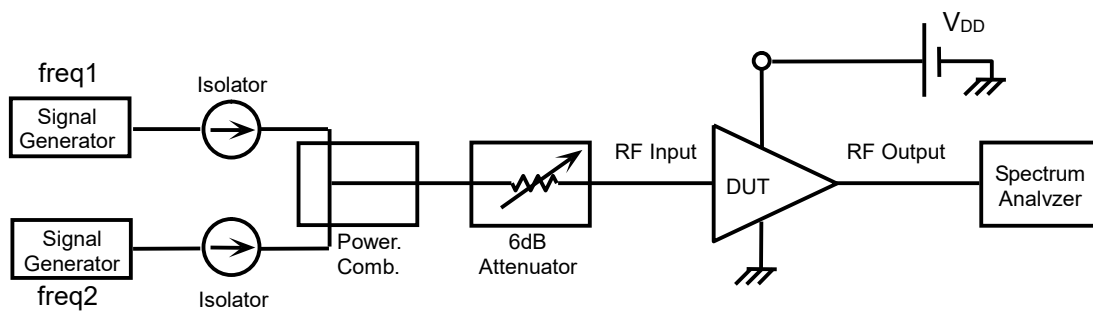

IF and IM3 Measurement Block Diagram for IIP3

• Noise Figure Measurements

Measuring instruments

NF Analyzer : Agilent 8973A, 8975A
 Noise Source : Agilent 346A

Setting the NF analyzer

Measurement mode form

Device under test : Amplifier
 System downconverter : off

Mode setup form

Sideband : LSB
 Averages : 16
 Average mode : Point
 Bandwidth : 4MHz
 Loss comp : off
 Tcold : setting the temperature of noise source (303.15K)

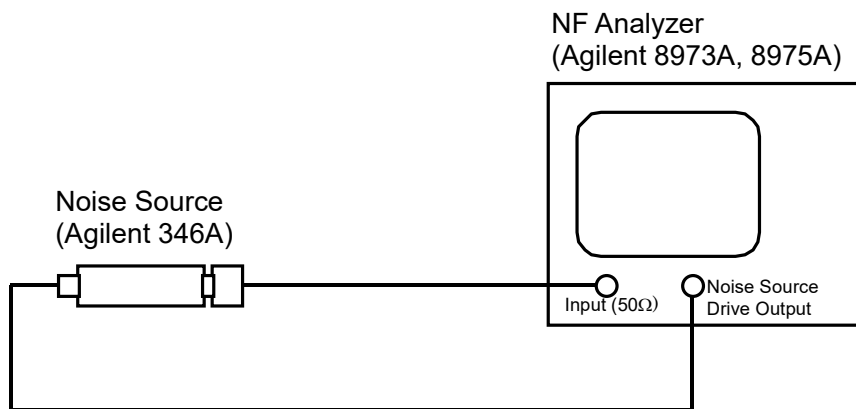

* Noise source and NF analyzer are connected directly.

Calibration Setup

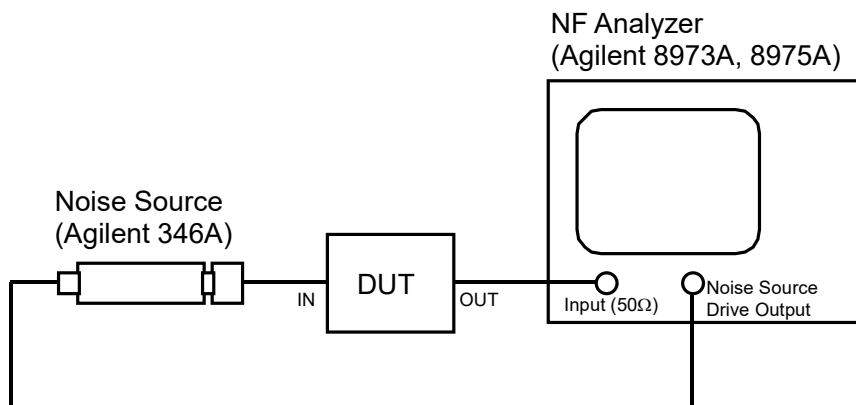

* Noise source and DUT, DUT and NF analyzer are connected directly.

Measurement Setup

■ PACKAGE OUTLINE (FLP6-A1)

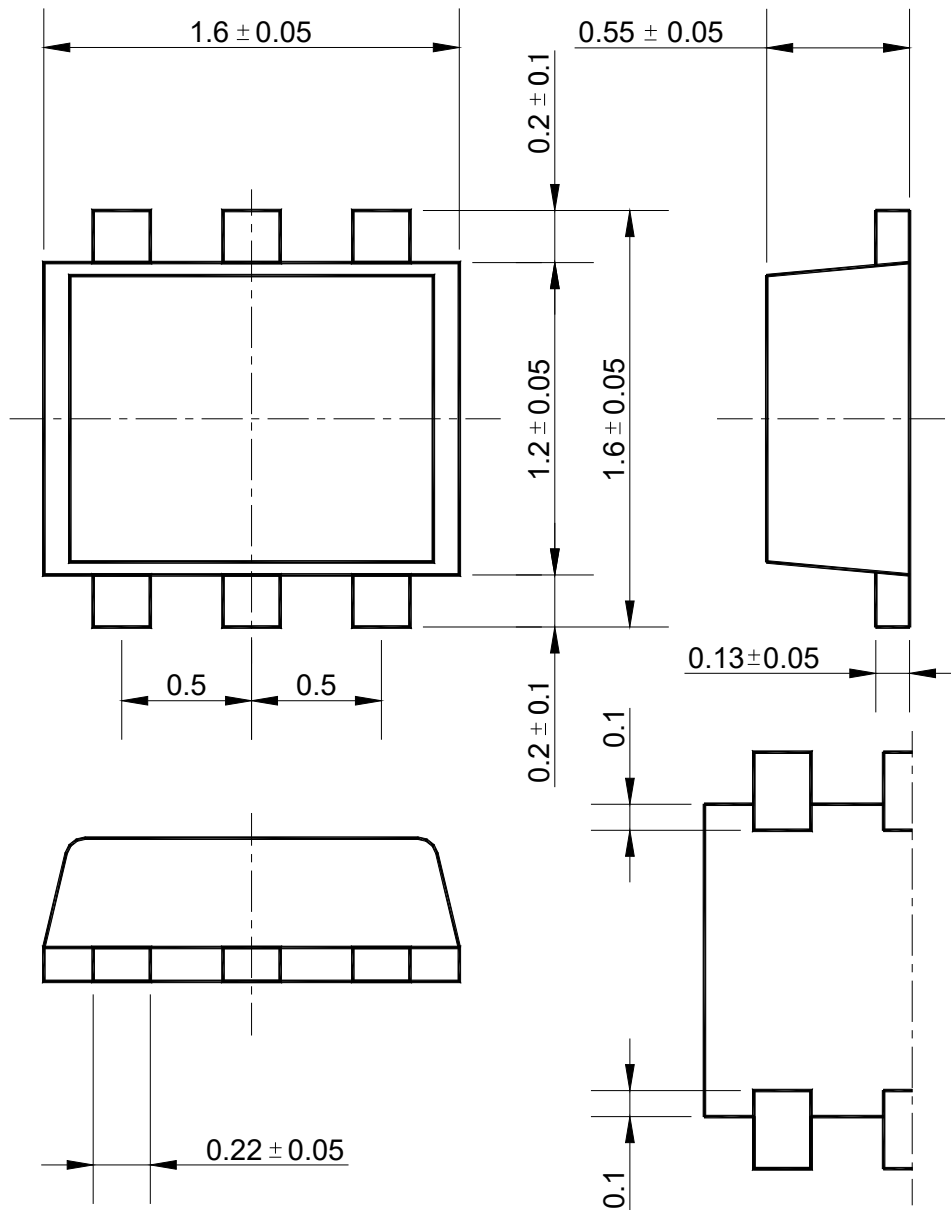

Unit: mm

Cautions on using this product

This product contains Gallium-Arsenide (GaAs) which is a harmful material.

- Do NOT eat or put into mouth.
- Do NOT dispose in fire or break up this product.
- Do NOT chemically make gas or powder with this product.
- To waste this product, please obey the relating law of your country.

This product may be damaged with electric static discharge (ESD) or spike voltage. Please handle with care to avoid these damages.

[CAUTION]

The specifications on this databook are only given for information, without any guarantee as regards either mistakes or omissions. The application circuits in this databook are described only to show representative usages of the product and not intended for the guarantee or permission of any right including the industrial rights.

1. The products and the product specifications described in this document are subject to change or discontinuation of production without notice for reasons such as improvement. Therefore, before deciding to use the products, please refer to our sales representatives for the latest information thereon.
2. The materials in this document may not be copied or otherwise reproduced in whole or in part without the prior written consent of us.
3. This product and any technical information relating thereto are subject to complementary export controls (so-called KNOW controls) under the Foreign Exchange and Foreign Trade Law, and related politics ministerial ordinance of the law. (Note that the complementary export controls are inapplicable to any application-specific products, except rockets and pilotless aircraft, that are insusceptible to design or program changes.) Accordingly, when exporting or carrying abroad this product, follow the Foreign Exchange and Foreign Trade Control Law and its related regulations with respect to the complementary export controls.
4. The technical information described in this document shows typical characteristics and example application circuits for the products. The release of such information is not to be construed as a warranty of or a grant of license under our or any third party's intellectual property rights or any other rights.
5. The products listed in this document are intended and designed for use as general electronic components in standard applications (office equipment, telecommunication equipment, measuring instruments, consumer electronic products, amusement equipment etc.). Those customers intending to use a product in an application requiring extreme quality and reliability, for example, in a highly specific application where the failure or misoperation of the product could result in human injury or death should first contact us.
 - Aerospace Equipment
 - Equipment Used in the Deep Sea
 - Power Generator Control Equipment (nuclear, steam, hydraulic, etc.)
 - Life Maintenance Medical Equipment
 - Fire Alarms / Intruder Detectors
 - Vehicle Control Equipment (automotive, airplane, railroad, ship, etc.)
 - Various Safety Devices
 - Traffic control system
 - Combustion equipment

In case your company desires to use this product for any applications other than general electronic equipment mentioned above, make sure to contact our company in advance. Note that the important requirements mentioned in this section are not applicable to cases where operation requirements such as application conditions are confirmed by our company in writing after consultation with your company.

6. We are making our continuous effort to improve the quality and reliability of our products, but semiconductor products are likely to fail with certain probability. In order to prevent any injury to persons or damages to property resulting from such failure, customers should be careful enough to incorporate safety measures in their design, such as redundancy feature, fire containment feature and fail-safe feature. We do not assume any liability or responsibility for any loss or damage arising from misuse or inappropriate use of the products.
7. The products have been designed and tested to function within controlled environmental conditions. Do not use products under conditions that deviate from methods or applications specified in this datasheet. Failure to employ the products in the proper applications can lead to deterioration, destruction or failure of the products. We shall not be responsible for any bodily injury, fires or accident, property damage or any consequential damages resulting from misuse or misapplication of the products.
8. **Quality Warranty**
 - 8-1. **Quality Warranty Period**

In the case of a product purchased through an authorized distributor or directly from us, the warranty period for this product shall be one (1) year after delivery to your company. For defective products that occurred during this period, we will take the quality warranty measures described in section 8-2. However, if there is an agreement on the warranty period in the basic transaction agreement, quality assurance agreement, delivery specifications, etc., it shall be followed.
 - 8-2. **Quality Warranty Remedies**

When it has been proved defective due to manufacturing factors as a result of defect analysis by us, we will either deliver a substitute for the defective product or refund the purchase price of the defective product.

Note that such delivery or refund is sole and exclusive remedies to your company for the defective product.
 - 8-3. **Remedies after Quality Warranty Period**

With respect to any defect of this product found after the quality warranty period, the defect will be analyzed by us. On the basis of the defect analysis results, the scope and amounts of damage shall be determined by mutual agreement of both parties. Then we will deal with upper limit in Section 8-2. This provision is not intended to limit any legal rights of your company.
9. Anti-radiation design is not implemented in the products described in this document.
10. The X-ray exposure can influence functions and characteristics of the products. Confirm the product functions and characteristics in the evaluation stage.
11. WLCSP products should be used in light shielded environments. The light exposure can influence functions and characteristics of the products under operation or storage.
12. Warning for handling Gallium and Arsenic (GaAs) products (Applying to GaAs MMIC, Photo Reflector). These products use Gallium (Ga) and Arsenic (As) which are specified as poisonous chemicals by law. For the prevention of a hazard, do not burn, destroy, or process chemically to make them as gas or power. When the product is disposed of, please follow the related regulation and do not mix this with general industrial waste or household waste.
13. Please contact our sales representatives should you have any questions or comments concerning the products or the technical information.



Nisshinbo Micro Devices Inc.

Official website

<https://www.nisshinbo-microdevices.co.jp/en/>

Purchase information

<https://www.nisshinbo-microdevices.co.jp/en/buy/>