

DESCRIPTION

The MP3414E is a high-efficiency, current-mode, synchronous step-up converter with output disconnect. It can start up from an input voltage (V_{IN}) as low as 0.8V. The device provides inrush current limiting and output short-circuit protection (SCP).

The integrated, P-channel synchronous rectifier improves efficiency and eliminates the need for an external Schottky diode. If the part shuts down, then the P-channel MOSFET disconnects the output from the input. Output disconnect allows the output to be discharged completely, which allows for the 1 μ A supply current in shutdown mode (I_{SD}).

The fixed 1MHz switching frequency (f_{SW}) allows for smaller external components. Internal compensation and soft start (SS) reduce the external component count, providing a compact solution.

The MP3414E features an integrated power MOSFET that supports up to 4V of output voltage (V_{OUT}) and up to 1.8A of peak current (I_{PEAK}).

The MP3414E is available in a small TSOT23-8 package.

FEATURES

- Up to 96% Efficiency
- 0.8V Low Start-Up Voltage (V_{SU})
- 0.6V to 4V Input Voltage (V_{IN}) Range
- 1.8V to 4V Output Voltage (V_{OUT}) Range
- Internal Synchronous Rectifier
- 1MHz Fixed Switching Frequency (f_{SW})
- 34 μ A Quiescent Current (I_Q) (40 μ A Max)
- 1 μ A Shutdown Current (I_{SD}) (2 μ A Max)
- True Output Disconnect from Input
- Down Mode ($V_{IN} > V_{OUT}$)
- Small External Components
- Inrush Current Limiting
- Internal Soft Start (SS)
- Over-Voltage Protection (OVP)
- Short-Circuit Protection (SCP)
- Available in a TSOT23-8 Package



Optimized Performance with MPS Inductor MPL-AL4020 Series

APPLICATIONS

- Battery-Powered Products
- Personal Medical Devices
- Portable Media Players
- Wireless Peripherals
- Handheld Computers and Smartphones

All MPS parts are lead-free, halogen-free, and adhere to the RoHS directive. For MPS green status, please visit the MPS website under Quality Assurance. "MPS", the MPS logo, and "Simple, Easy Solutions" are trademarks of Monolithic Power Systems, Inc. or its subsidiaries.

TYPICAL APPLICATION

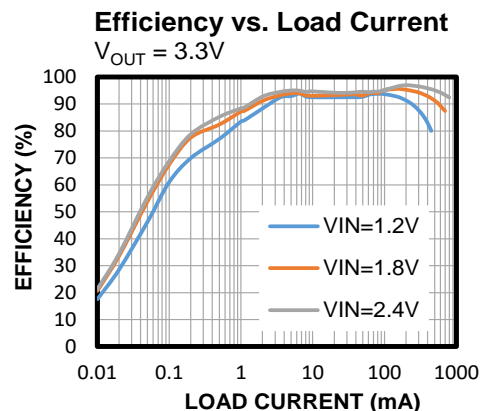
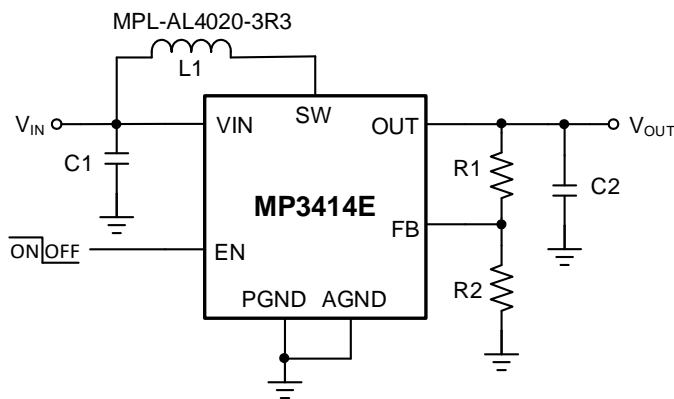

ORDERING INFORMATION

Part Number*	Package	Top Marking	MSL Rating
MP3414EGJ	TSOT23-8	See Below	1

* For Tape & Reel, add suffix -Z (e.g. MP3414EGJ-Z).

TOP MARKING

| BPCY

Y: Year code
BPC: Product code

PACKAGE REFERENCE

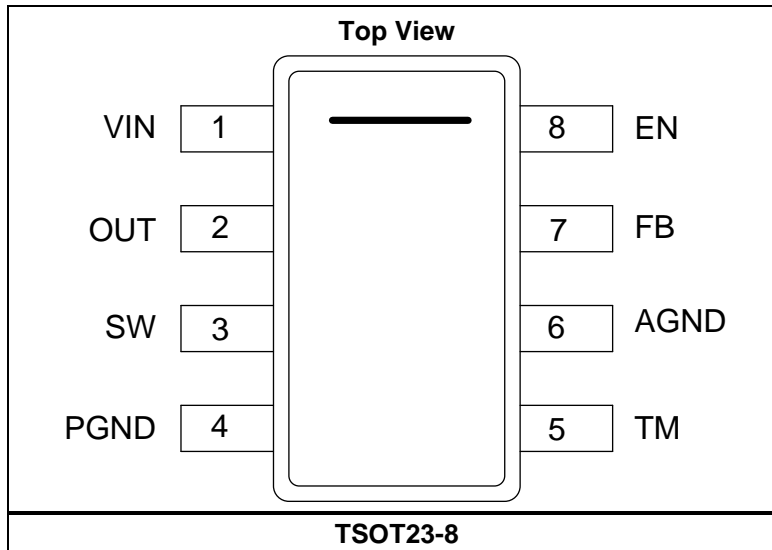

PIN FUNCTIONS

Pin #	Name	Description
1	VIN	Input voltage. The VIN pin requires bypass capacitor.
2	OUT	Output. The OUT pin is the source of the internal synchronous rectifier. Connect the output capacitor (C _{OUT}) between the OUT and PGND pins.
3	SW	Switch output. Connect the inductor to the SW pin to complete the step-up converter.
4	PGND	Power ground. Reference ground of the regulated output voltage.
5	TM	Test mode pin. Factory use only. Float the TM pin or connect the TM and AGND pins in application.
6	AGND	Analog ground.
7	FB	Feedback. To set the output voltage (V _{OUT}), connect the FB pin to the tap of an external resistive voltage divider connected between OUT and AGND.
8	EN	Enable. The EN pin enables and disabled the converter. Pull the EN pin above 0.8V x V _{IN} to turn the converter on; pull EN to ground to turn it off. EN is pulled up to VIN internally via a 1.5MΩ pull-up resistor.

ABSOLUTE MAXIMUM RATINGS ⁽¹⁾

V_{SW}, V_{OUT} -0.5V to +6.5V
 All other pins -0.5V to +6V
 Continuous power dissipation (T_A = 25°C) ⁽²⁾
 2.19 W ⁽⁴⁾
 Junction temperature 150°C
 Lead temperature 260°C
 Storage temperature -65°C to +150°C

ESD Ratings

Human body model (HBM) 2000V
 Charged device model (CDM) 1500V

Recommended Operating Conditions ⁽³⁾

Start-up voltage (V_{SU}) 0.8V to 4V
 Input voltage (V_{IN}) 0.6V to 4V
 Output voltage (V_{OUT}) 1.8V to 4V
 Operating junction temp (T_J) -40°C to +125°C

Thermal Resistance	θ_{JA}	θ_{JC}
TSOT23-8		
EVL3414E-J-00A ⁽⁴⁾	57	15
JESD51-7 ^{(5) (6)}	100	55

Notes:

- 1) Exceeding these ratings may damage the device.
- 2) The maximum allowable power dissipation is a function of the maximum junction temperature T_J (MAX), the junction-to-ambient thermal resistance θ_{JA} , and the ambient temperature T_A. The maximum allowable continuous power dissipation at any ambient temperature is calculated by P_D (MAX) = (T_J (MAX) - T_A) / θ_{JA} . Exceeding the maximum allowable power dissipation can produce an excessive die temperature, which may cause the converter to go into thermal shutdown. Internal thermal shutdown circuitry protects the device from permanent damage.
- 3) The device is not guaranteed to function outside of its operating conditions.
- 4) Measured on EVL3414E-J-00A (63mmx63mm), 2-layer PCB.
- 5) The value of θ_{JA} given in this table is only valid for comparison with other packages and cannot be used for design purposes.
- 6) These values are calculated in accordance with JESD51-7, and simulated on a specified JEDEC board. They do not represent the performance obtained in an actual application.

ELECTRICAL CHARACTERISTICS

$V_{IN} = V_{EN} = 1.8V$, $V_{OUT} = 3.3V$, $T_J = 25^\circ C$, unless otherwise noted.

Parameters	Symbol	Condition	Min	Typ	Max	Units
Minimum start-up voltage	V_{SU}			0.8	1	V
Operating input voltage	V_{IN}		0.6		4	V
Output voltage	V_{OUT}		1.8		4	V
Quiescent current	I_Q	$V_{EN} = V_{IN} = 1.8V$, $V_{OUT} = 3.3V$, no load, measured on the OUT pin		34	40	μA
Shutdown current	I_{SD}	$V_{EN} = V_{OUT} = 0V$, measured on the VIN pin		1	2	μA
V_{IN} under-voltage lockout (UVLO) threshold	V_{IN_UVLO}	V_{IN} rising	0.4	0.5	0.6	V
Switching frequency	f_{SW}		0.85	1	1.15	MHz
Feedback voltage	V_{FB}	$T_J = 25^\circ C$	1.197	1.21	1.223	V
		$T_J = -40^\circ C$ to $+125^\circ C$	1.191	1.21	1.229	V
Feedback current	I_{FB}	$V_{FB} = 1.25V$		1	50	nA
N-channel MOSFET on resistance	$R_{DS(ON)_N}$			110		m Ω
N-channel MOSFET leakage current	I_{LKG_N}	$V_{SW} = 6.5V$		0.1	1	μA
P-channel MOSFET on resistance	$R_{DS(ON)_P}$			120		m Ω
P-channel MOSFET leakage current	I_{LKG_P}	$V_{SW} = 6.5V$, $V_{OUT} = 0V$		0.1	1	μA
Maximum duty cycle	D_{MAX}		89	95		%
Start-up current limit	I_{LIMIT_SU}			0.75		A
N-channel MOSFET current limit	I_{LIMIT_SW}		1.5	1.8		A
EN high voltage	V_{EN_HIGH}		$0.8 \times V_{IN}$			V
EN low voltage	V_{EN_LOW}				$0.2 \times V_{IN}$	V
EN current	I_{EN}	Connect to VIN		10		nA
Thermal shutdown ⁽⁷⁾				150		$^\circ C$
Thermal hysteresis ⁽⁷⁾				20		$^\circ C$

Note:

7) Guaranteed by sample characterization. Not production tested.

TYPICAL CHARACTERISTICS

$V_{IN} = 1.8V$, $V_{OUT} = 3.3V$, $L = 3.3\mu H$, $T_A = 25^\circ C$, unless otherwise noted.

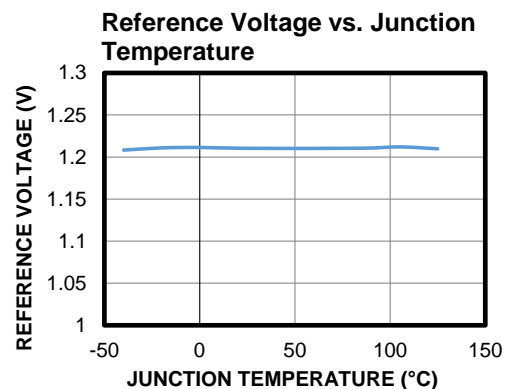
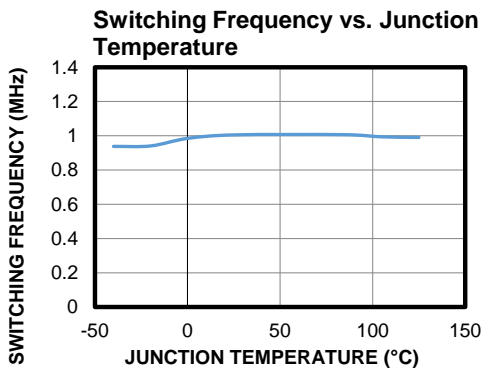
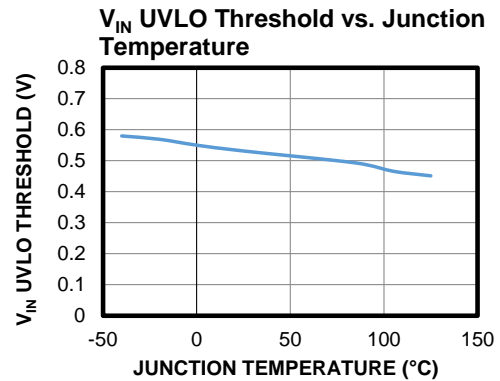
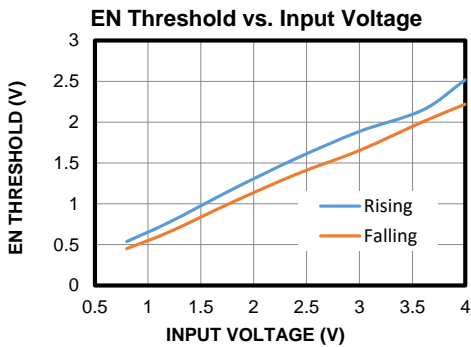
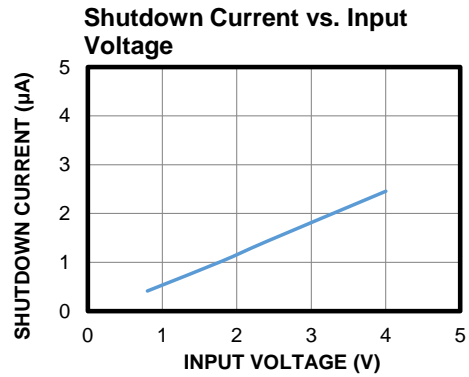
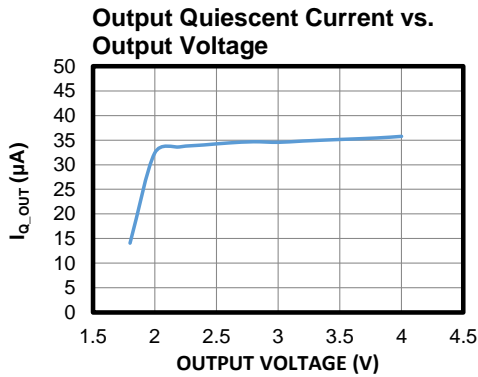

TYPICAL PERFORMANCE CHARACTERISTICS

$V_{IN} = 1.8V$, $V_{OUT} = 3.3V$, $L = 3.3\mu H$, $T_A = 25^\circ C$, unless otherwise noted.

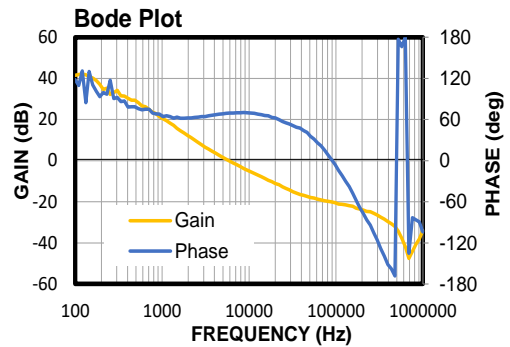
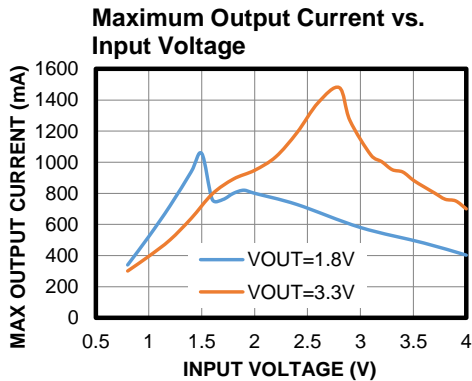
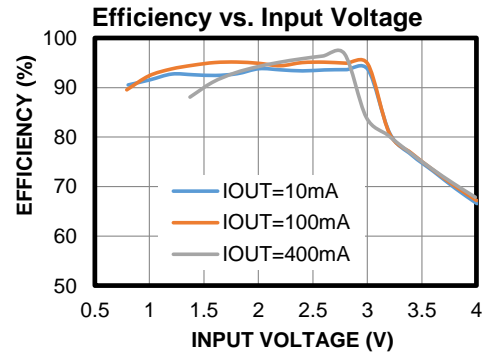
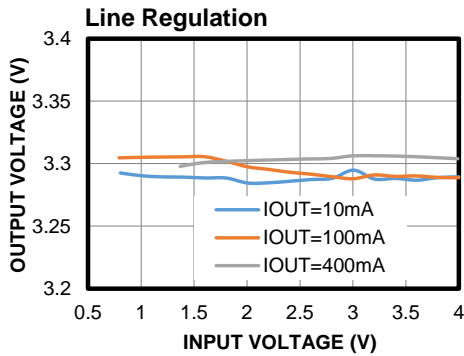
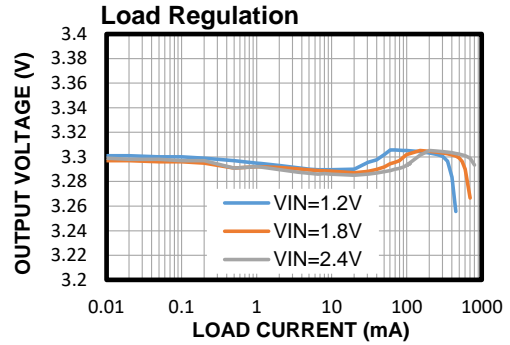
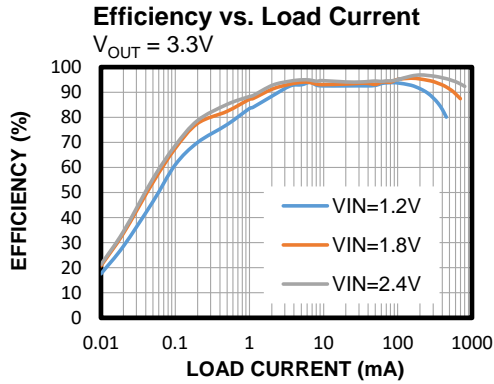

TYPICAL PERFORMANCE CHARACTERISTICS *(continued)*

$V_{IN} = 1.8V$, $V_{OUT} = 3.3V$, $L = 3.3\mu H$, $T_A = 25^\circ C$, unless otherwise noted.

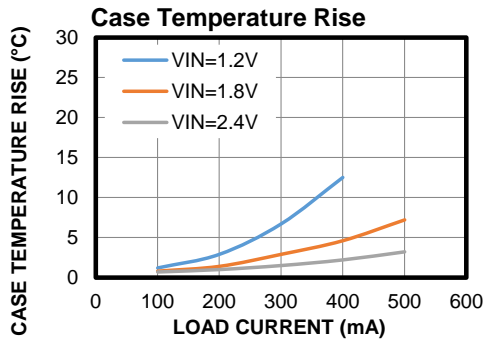

TYPICAL PERFORMANCE CHARACTERISTICS (continued)

$V_{IN} = 1.8V$, $V_{OUT} = 3.3V$, $L = 3.3\mu H$, $T_A = 25^\circ C$, unless otherwise noted.

Steady State

$I_{OUT} = 0A$

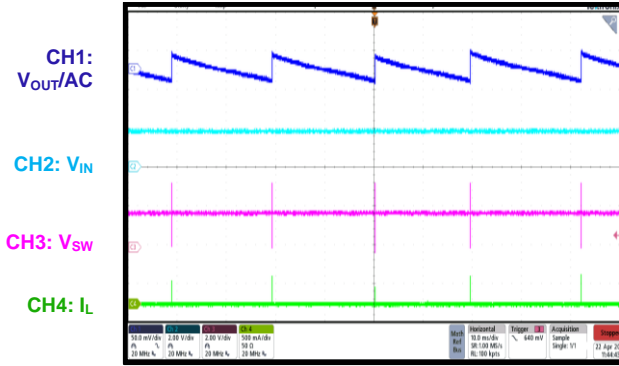

Steady State

$I_{OUT} = 0.5A$

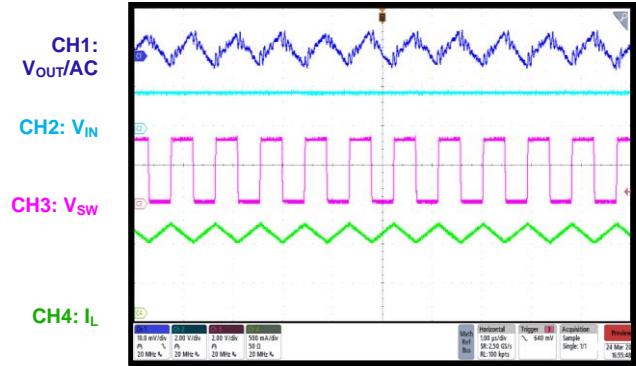

Start-Up through VIN

$I_{OUT} = 0A$

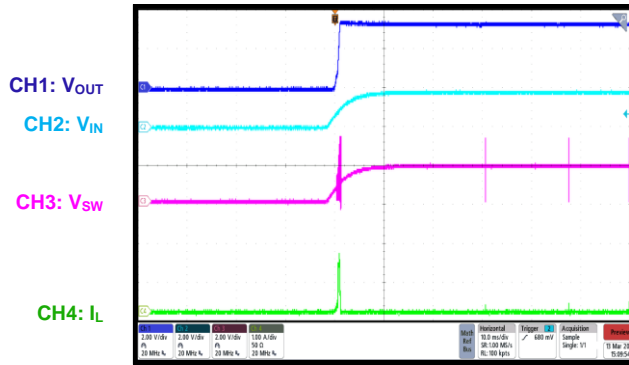

Start-Up through VIN

$I_{OUT} = 0.5A$

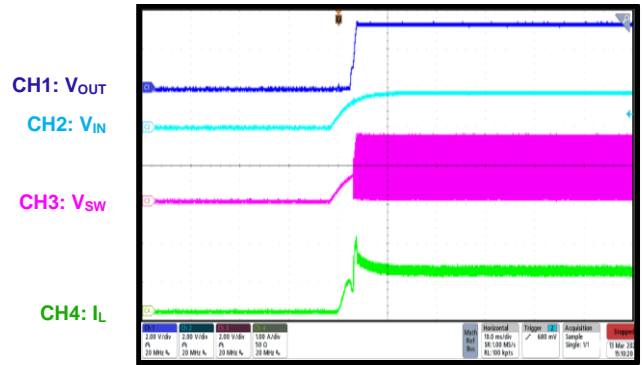

Shutdown through VIN

$I_{OUT} = 0A$

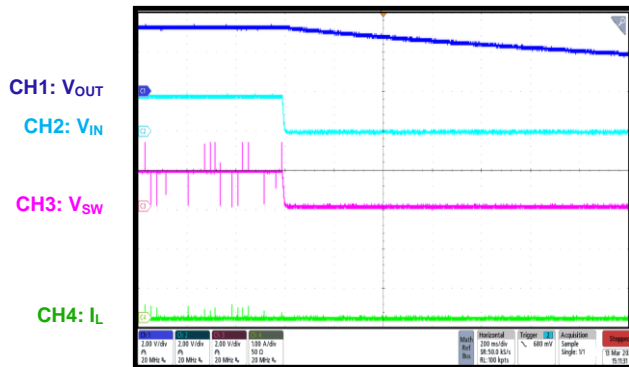

Shutdown through VIN

$I_{OUT} = 0.5A$

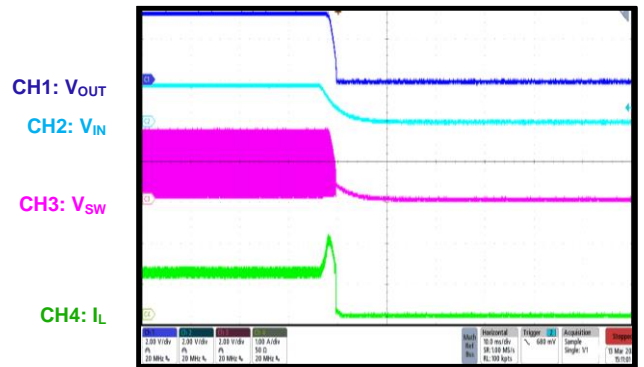

TYPICAL PERFORMANCE CHARACTERISTICS (continued)

$V_{IN} = 1.8V$, $V_{OUT} = 3.3V$, $L = 3.3\mu H$, $T_A = 25^\circ C$, unless otherwise noted.

Start-Up through EN

$I_{OUT} = 0A$

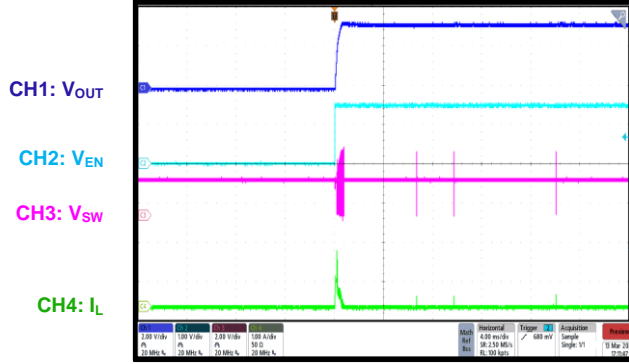

EN startup

$I_{OUT} = 0.5A$

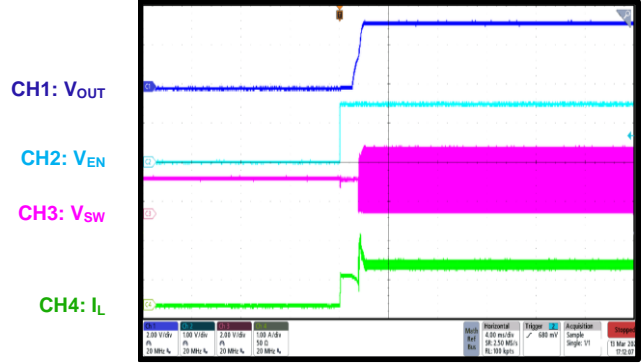

Shutdown through EN

$I_{OUT} = 0A$

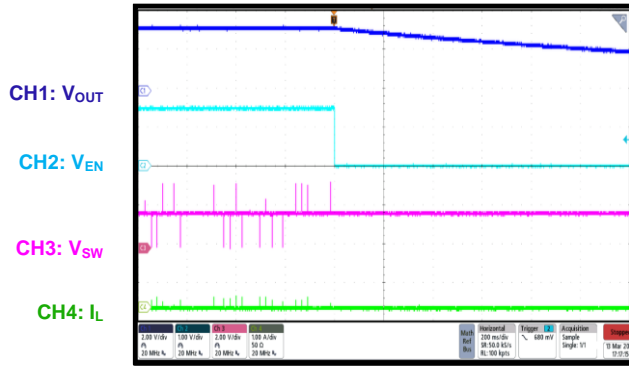

Shutdown through EN

$I_{OUT} = 0.5A$

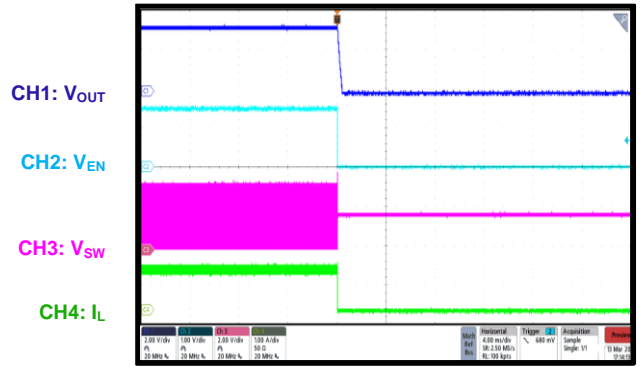

Load Transient

$I_{OUT} = 0A$ to $0.25A$, $25mA/\mu s$ slew rate

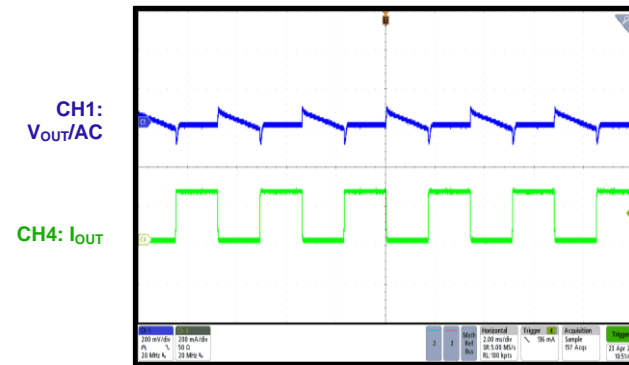

Load Transient

$I_{OUT} = 0.25A$ to $0.5A$, $25mA/\mu s$ slew rate

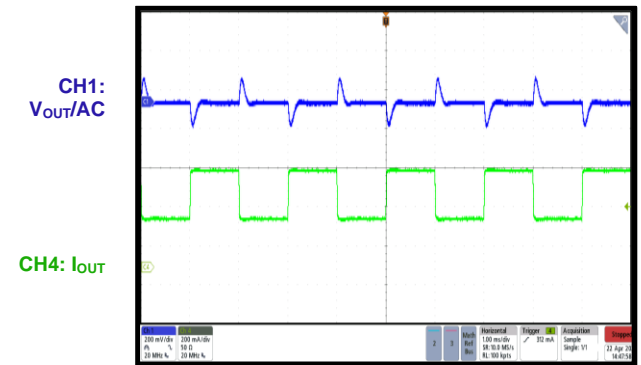

TYPICAL PERFORMANCE CHARACTERISTICS (continued)

$V_{IN} = 1.8V$, $V_{OUT} = 3.3V$, $L = 3.3\mu H$, $T_A = 25^\circ C$, unless otherwise noted.

OCP Entry
 $I_{OUT} = 0A$ to $1A$

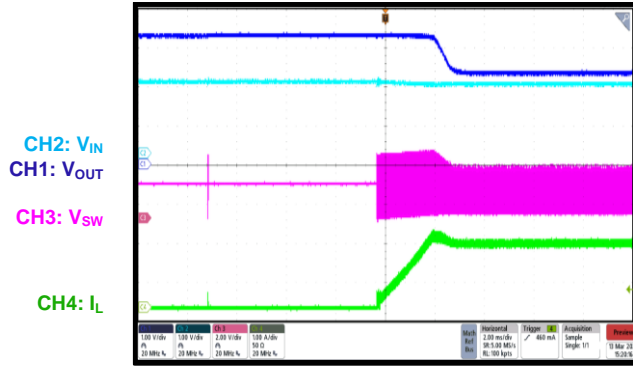

OCP Recovery
 $I_{OUT} = 1A$ to $0A$

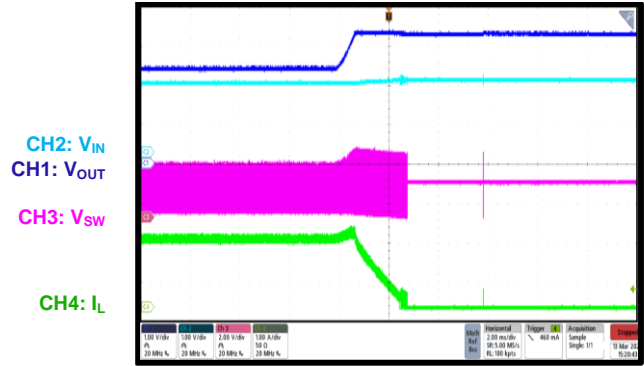

SCP Entry
 $I_{OUT} = 0A$ to short

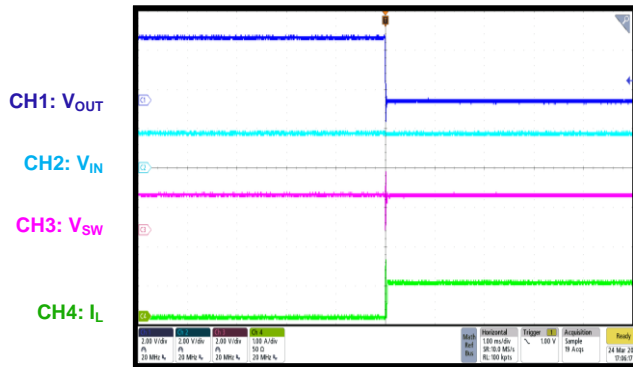

SCP Entry
 $I_{OUT} = 0.5A$ to short

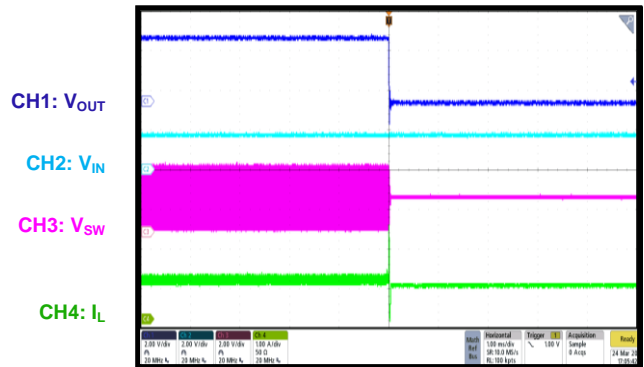

SCP Recovery
 $I_{OUT} = \text{short to } 0A$

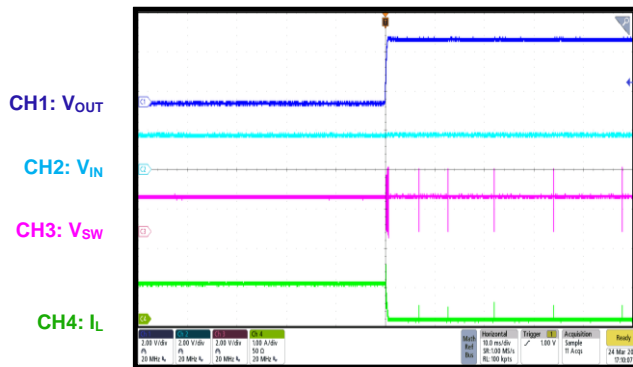

SCP Recovery
 $I_{OUT} = \text{short to } 0.5A$

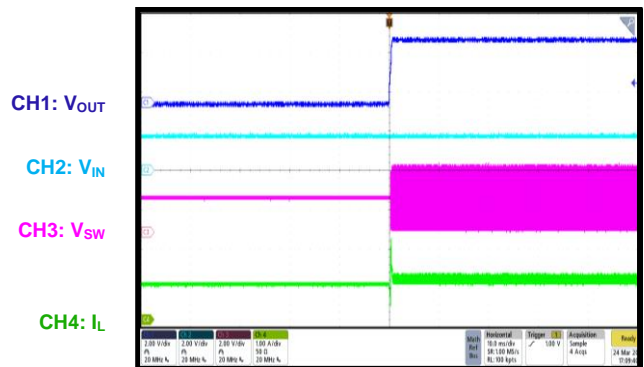

FUNCTIONAL BLOCK DIAGRAM

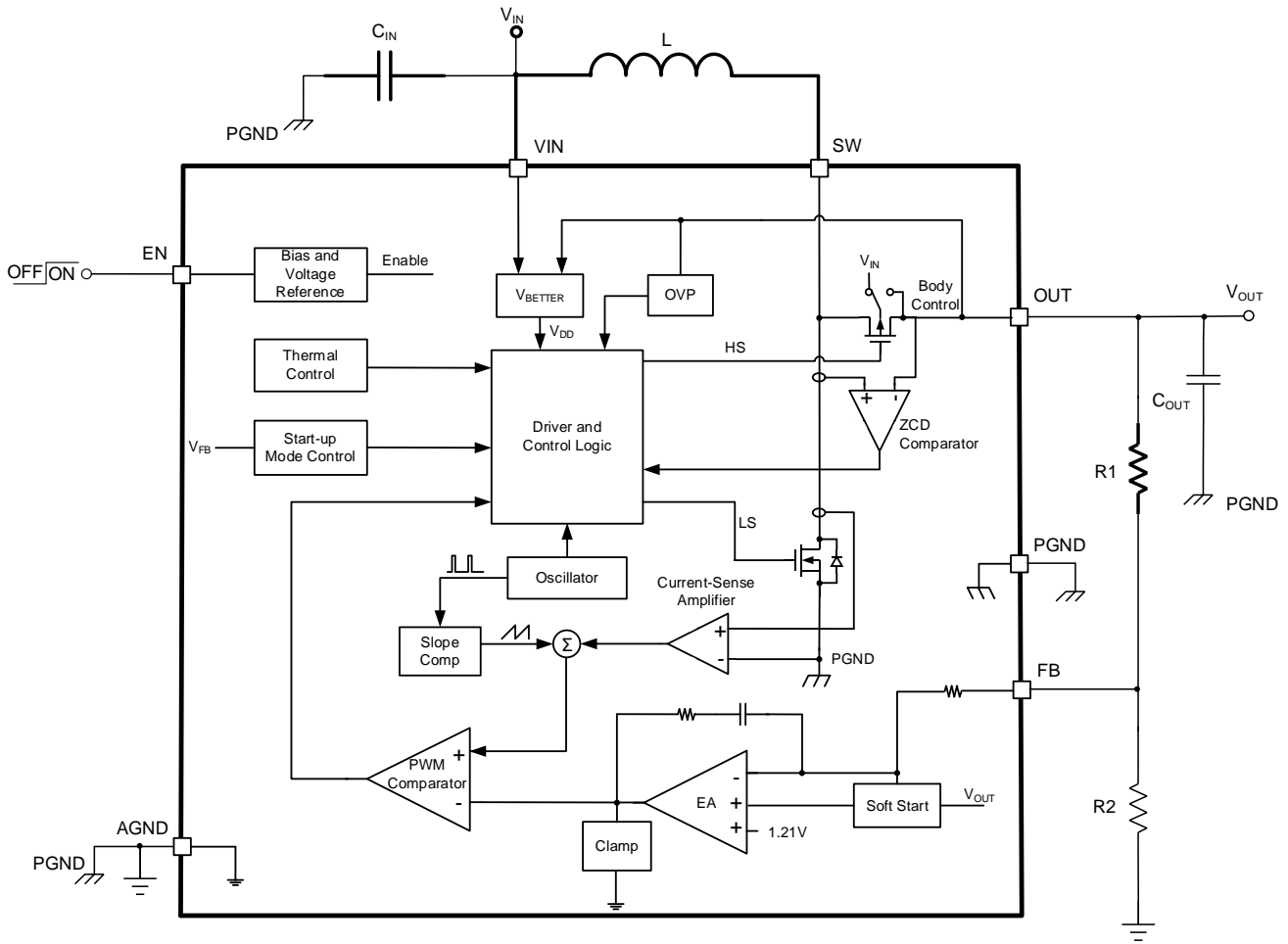

Figure 1: Functional Block Diagram

OPERATION

The MP3414E is a high-efficiency, current-mode, synchronous step-up converter with true output disconnect in a compact TSOT23-8 package. It can operate at input voltages (V_{IN}) down to 0.6V. Fixed-frequency, pulse-width modulation (PWM) current control mode provides excellent load and line regulation. Internal soft start (SS) and internal loop compensation simplifies design and reduces the external component count. The internal low on resistance ($R_{DS(ON)}$) MOSFETs and power save mode (PSM) allow the device to maintain high efficiency across a wide current load range.

Synchronous Rectifier

The MP3414E integrates an N-channel MOSFET and a P-channel MOSFET to achieve a synchronous boost. Replacing the traditional Schottky diode with a low- $R_{DS(ON)}$ P-channel MOSFET improves efficiency. In a conventional synchronous rectifier, the P-channel MOSFET body diode is forward-biased, and the current flows from the input to the output. The MP3414E allows for true output disconnect by eliminating the body diode, which prevents battery depletion if the converter shuts down. To prevent excessive inductor current (I_L), the P-channel MOSFET synchronous rectifier only functions while V_{OUT} exceeds $V_{IN} + 200mV$.

Start-Up

If the EN pin is on, then the MP3414E starts up and begins operating in linear charge mode. In linear charge mode, the P-channel MOSFET rectifier turns on until the output voltage (V_{OUT}) is charged to $V_{IN} - 200mV$. The P-channel MOSFET current (I_P) is limited to about 750mA to avoid inrush current. This circuit also limits the output current (I_{OUT}) if a short occurs.

The device starts switching after exiting linear charge mode. If V_{OUT} is below 1.7V, then the part operates in free-running mode. In free-running mode, the device operates at a fixed switching frequency (f_{SW}) (500kHz) with open-loop control. The duty cycle is determined by the input to output ratio. The switching current is limited to 1.2A to reduce start-up inrush current.

The soft-start voltage (V_{SS}) continues to rise,

following the feedback (FB) voltage (V_{FB}) during start-up and in free-running mode. Once the V_{OUT} exceeds 1.7V, then the part operates with closed-loop control. V_{OUT} rises according to V_{SS} , and the current limit (I_{LIMIT}) is set at 1.8A. Then the parts operates in either boost mode or down mode, depending on V_{IN} and V_{OUT} . Table 1 lists the operation modes during start-up.

Table 1: Operation Mode during Start-Up

V_{OUT}	Mode
$V_{OUT} < V_{IN} - 200mV$, $V_{OUT} < 1.7V$	Linear charge mode
$V_{OUT} \geq V_{IN} - 200mV$, $V_{OUT} < 1.7V$	Free-running mode
$V_{OUT} < V_{IN} + 200mV$, $V_{OUT} \geq 1.7V$	Down mode
$V_{OUT} > V_{IN} + 200mV$, $V_{OUT} \geq 1.7V$	Boost mode

In boost mode ($V_{OUT} > V_{IN} + 200mV$), the MP3414E is supplied by V_{OUT} instead of V_{IN} . This allows the battery voltage (V_{BATT}) to drop down to 0.6V without affecting the operation. The battery supplies sufficient energy to the output, becoming the only limiting factor in application.

Enable (EN)

Pull EN above $0.8V \times V_{IN}$ to turn the converter on; pull EN to ground to turn it off. In shutdown mode, the converter stops switching, the internal circuitry turns off, and the P-channel MOSFET rectifier's body diode conduction is reduced. This isolates the load from the input, which allows V_{OUT} to drop below V_{IN} during shutdown.

Power-Save Mode (PSM)

If the load decreases, the MP3414E enters power-save mode (PSM) automatically. Once the load increases, the part exits PSM and enters PWM mode. In PSM, the converter only operates if V_{OUT} drops below the set threshold. V_{OUT} ramps up a few pulses at the same f_{SW} as in PWM mode. Once V_{OUT} exceeds the rising threshold, the device stops switching. PSM requires fewer circuit resources than PWM mode. In PSM, all unused circuitry is disabled to reduce quiescent power dissipation and switching power loss. The output-monitoring circuit, as well as the error amplifier (EA) with

loop compensation for peak current control mode remain active during PSM.

The output voltage ripple (ΔV_{OUT}) (typically 1% peak to peak) can be reduced using a larger-value the output capacitor (C_{OUT}) and by adding a small feed-forward capacitor (about 10pF). The MP3414E operates in either PSM or PWM mode depending on the load, which varies according to V_{IN} , C_{OUT} , and the inductor value.

Under-Voltage Lockout (UVLO) Protection

Under-voltage lockout (UVLO) protection prevents the device from starting up at an insufficient V_{IN} (<0.5V) during operation, and while the battery is being discharged.

Error Amplifier (EA)

The MP3414E features an error amplifier (EA) with internal compensation. The EA compares the internal reference voltage (V_{REF}) (1.21V) and V_{FB} to generate an error signal. V_{OUT} can be set between 1.8V and 4V by connecting FB to the tap of an external voltage divider connected between OUT and AGND. V_{OUT} can be calculated with Equation (1):

$$V_{OUT} = 1.21V \times \left(1 + \frac{R1}{R2}\right) \quad (1)$$

Choose the largest-value resistors possible for R1 and R2 to achieve a low quiescent current (I_Q). For most applications, choose R1 to be >300k Ω to achieve good stability and transient balance.

Current Sensing

Lossless current sensing converts the N-channel MOSFET's switching current signal to a voltage that can be summed with the internal slope compensator. The difference between this summed signal and the EA output controls the peak current (I_{PEAK}) in PWM mode. I_{PEAK} is limited to about 1.8A, and is independent of V_{IN} and V_{OUT} . The switching current signal is blanked for 60ns to enhance noise rejection.

Thermal Shutdown

The MP3414E monitors the temperature internally. If the die temperature exceeds the

thermal shutdown threshold (typically 150°C), the device shuts down. Once V_{OUT} drops below 1.7V, the device starts up.

Output Disconnect and Inrush Current Limiting

The MP3414E is designed to allow true output disconnect by eliminating the internal P-channel MOSFET rectifier's body diode conduction. This feature allows V_{OUT} to drop to 0V during shutdown, and allows for a 0A input current. It also allows for inrush current limiting, which minimizes input inrush currents at the input during start-up. Note that to optimize the output disconnect function, do not include the external Schottky diode connected between the SW and OUT pins.

Place the output filter capacitor as close to OUT as possible to minimize overshoot on the SW pin due to stray inductance. Use ultra-low ESR/ESL ceramic capacitors connected to a clean ground plane.

Short-Circuit Protection (SCP)

Unlike most step-up converters, the MP3414E allows for short circuits on the output. If a short occurs, the device turns the N-channel MOSFET off once the sensed current reaches I_{LIMIT} . The current is limited in linear charge mode, as it is during start-up. If the die temperature exceeds 150°C, then the thermal regulation circuit further controls the input current (I_{IN}).

Down Mode ($V_{IN} > V_{OUT}$)

In down mode, the MP3414E continues to regulate V_{OUT} even while V_{IN} exceeds V_{OUT} . This is achieved by turning the synchronous P-channel MOSFET off, and applying V_{IN} to its gate statically. This ensures that the I_L slope is reversed while the current flows to the output. Power dissipation increases in down mode since the P-channel MOSFET does not act as a low-impedance switch while in down mode. This causes a significant drop in efficiency. Limit the maximum I_{OUT} (I_{OUT_MAX}) to maintain an acceptable junction temperature (T_J).

APPLICATION INFORMATION

Selecting the Input Capacitor (C_{IN})

Low ESR input capacitors reduce input switching noise and I_{PEAK} drawn from the battery. Place ceramic decoupling capacitors as close to the device as possible. Place a >10µF ceramic capacitor close to the IC.

Selecting the Output Capacitor (C_{OUT})

Choose a ≥22µF output capacitor (C_{OUT}) to stabilize V_{OUT} across the entire V_{IN} range. A higher capacitance may be required to reduce ΔV_{OUT} and transient response. Low ESR ceramic capacitors with X5R or X7R dielectrics are recommended. If the ESR is 0Ω, then the minimum C_{OUT} (C_{OUT_MIN}) to support ΔV_{OUT} in PWM mode can be calculated with Equation (2):

$$C_{OUT_MIN} \geq \frac{I_{OUT} \times (V_{OUT_MAX} - V_{IN_MIN})}{f_{SW} \times V_{OUT_MAX} \times \Delta V_{OUT}} \quad (2)$$

Where V_{OUT_MAX} is the maximum V_{OUT}, and V_{IN_MIN} is the minimum V_{IN}.

A larger-value capacitor may be required for applications where V_{OUT} is close to V_{IN} to reduce ΔV_{OUT}, and ensure a stable V_{OUT} in PSM mode (especially at higher output load currents).

Selecting the Inductor

The MP3414E can work with small, surface-mounted inductors due to its 1MHz f_{SW}. A 1.5µH to 4.7µH inductor is suitable for most applications. For most designs, the inductance (L) can be calculated with Equation (3):

$$L = \frac{V_{IN} \times (V_{OUT} - V_{IN})}{V_{OUT} \times F_{SW} \times \Delta I_L} \quad (3)$$

Where ΔI_L is the acceptable inductor ripple current.

Choose ΔI_L to be between 30% and 50% of the average I_L. Choose an inductor with a low DCR to reduce resistive power loss, and a large enough saturation current (I_{SAT}) to support I_{L_PEAK}.

MPS inductors are optimized and tested for use with our complete line of integrated circuits.

Table 2 lists our power inductor recommendations. Select a part number based on your design requirements.

Table 2: Power Inductor Selection

Part Number	Inductor Value	Manufacturer
MPL-AL4020-3R3	3.3µH	MPS
MPL-AL4020-2R2	2.2µH	MPS
MPL-AL4020-4R7	4.7µH	MPS

Visit MonolithicPower.com under Products > Inductors for more information.

Design Example

Table 3 shows a design example for the specifications below.

Table 3: Design Example

V _{IN}	0.8V to 4V
V _{OUT}	3.3V

The detailed application schematic is shown in Figure 3 on page 16. See the Typical Performance Characteristics section on page 6 for more details. Refer to related evaluation board datasheet for more device applications.

PCB Layout Guidelines

Efficient PCB layout is critical for stable operation. Poor layout design can result in excessive EMI, resistive loss, and system instability. For the best results, refer to Figure 2 and follow the guidelines below:

1. Place a >100nF decoupling capacitor between the OUT and PGND pins. Place this capacitor as close to the OUT pin as possible.
2. Avoid placing vias between the OUT pin and C_{OUT} to reduce EMI and voltage spikes at SW.
3. Place C_{IN}, C_{OUT}, and the inductor as close to the IC as possible using a short and wide trace.
4. Place the feedback resistors as close to AGND as possible.
5. Use a large copper ground area to reduce the die temperature.

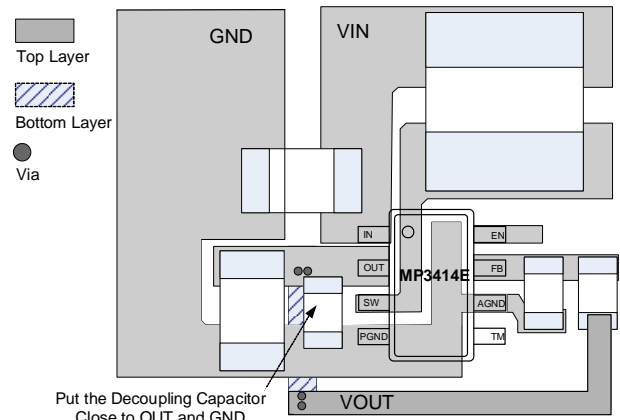

Figure 2: Recommended PCB Layout

TYPICAL APPLICATION CIRCUIT

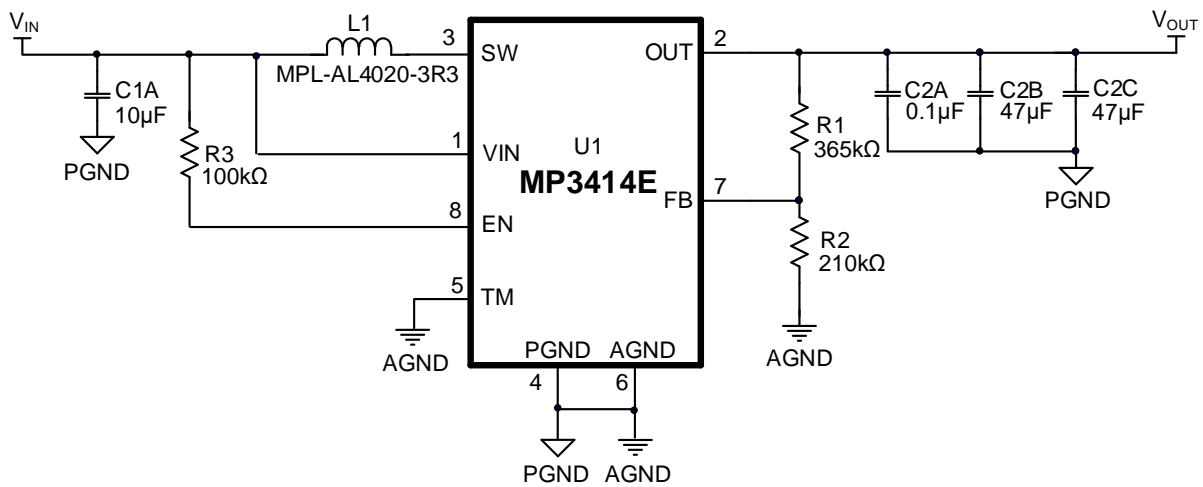
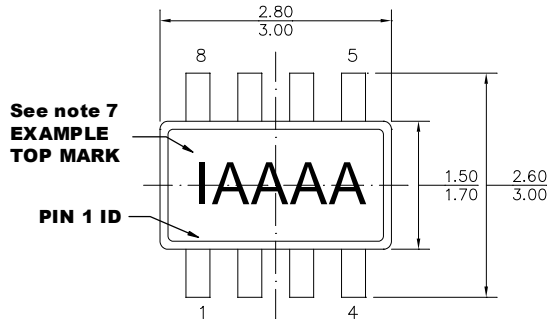

Figure 3: Typical Application Circuit (Boost, $V_{IN} = 0.8V$ to $4V$, $V_{OUT} = 3.3V$)

PACKAGE INFORMATION

TSOT23-8



TOP VIEW

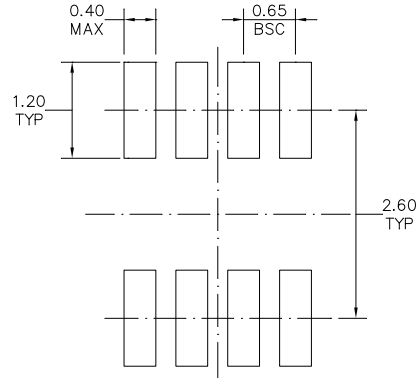

RECOMMENDED LAND PATTERN

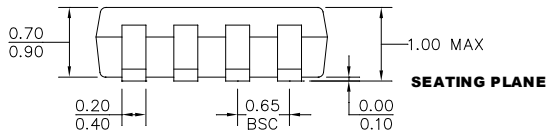

FRONT VIEW

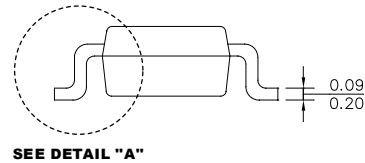

SIDE VIEW

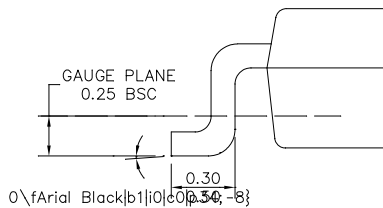

DETAIL "A"

NOTE:

- 1) ALL DIMENSIONS ARE IN MILLIMETERS.
- 2) PACKAGE LENGTH DOES NOT INCLUDE MOLD FLASH, PROTRUSION, OR GATE BURR.
- 3) PACKAGE WIDTH DOES NOT INCLUDE INTERLEAD FLASH OR PROTRUSION.
- 4) LEAD COPLANARITIES (BOTTOM OF LEADS AFTER FORMING) SHALL BE 0.1 MILLIMETERS MAX.
- 5) JEDEC REFERENCE IS MO-193, VARIATION BA.
- 6) DRAWING IS NOT TO SCALE.
- 7) PIN 1 IS THE LOWER LEFT PIN WHEN READING THE TOP MARK FROM LEFT TO RIGHT (SEE EXAMPLE TOP MARK).

CARRIER INFORMATION

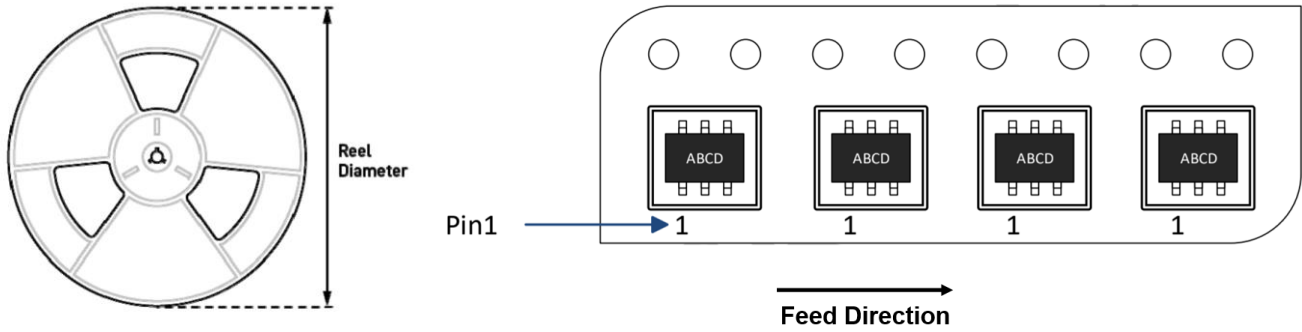

Part Number	Package Description	Quantity/ Reel	Quantity/ Tube	Quantity/ Tray	Reel Diameter	Carrier Tape Width	Carrier Tape Pitch
MP3414EGJ-Z	TSOT23-8	3000	N/A	N/A	7in	8mm	4mm

REVISION HISTORY

Revision #	Revision Date	Description	Pages Updated
1.0	4/11/2022	Initial Release	-

Notice: The information in this document is subject to change without notice. Please contact MPS for current specifications. Users should warrant and guarantee that third-party Intellectual Property rights are not infringed upon when integrating MPS products into any application. MPS will not assume any legal responsibility for any said applications.