

DESCRIPTION

The MP3309L is a WLED step-up converter for 2.7V to 5.5V input that uses peak-current mode to regulate the LED current sensed through an external, low-side resistor. The 200mV feedback voltage and synchronous rectification reduces power loss and reduces PCB space requirements.

The MP3309L features a programmable switching frequency to optimize efficiency. It supports both analog and PWM dimming.

In addition, the MP3309L has LED open protection, cycle-by-cycle current limit protection, thermal shutdown protection.

FEATURES

- 2.7V to 5.5V Input Voltage
- Analog and PWM Dimming
- Programmable Switching Frequency
- 24V Open-Load Protection
- Low 200mV Feedback Voltage with $\pm 1\%$ Accuracy at Room Temperature
- UVLO, Thermal Shutdown
- Available in a 1.4mmx1.8mm QFN-10 Package

APPLICATIONS

- Feature Phones and Smart Phones
- Tablets
- <10inch Video Displays

All MPS parts are lead-free, halogen-free, and adhere to the RoHS directive. For MPS green status, please visit the MPS website under Quality Assurance. "MPS" and "The Future of Analog IC Technology" are registered trademarks of Monolithic Power Systems, Inc.

TYPICAL APPLICATION

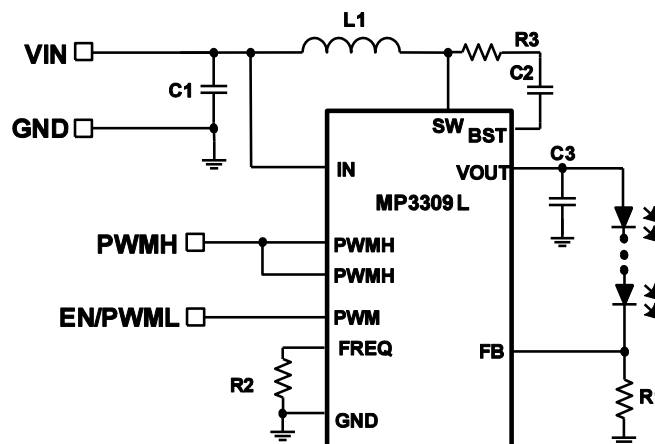

ORDERING INFORMATION

Part Number*	Package	Top Marking
MP3309LGQG	QFN-10 (1.4mmx1.8mm)	See Below

* For Tape & Reel, add suffix -Z (e.g. MP3309LGQG-Z).

TOP MARKING

—
CU
LL

CU: product code of MP3309LGQG;
LL: lot number;

PACKAGE REFERENCE

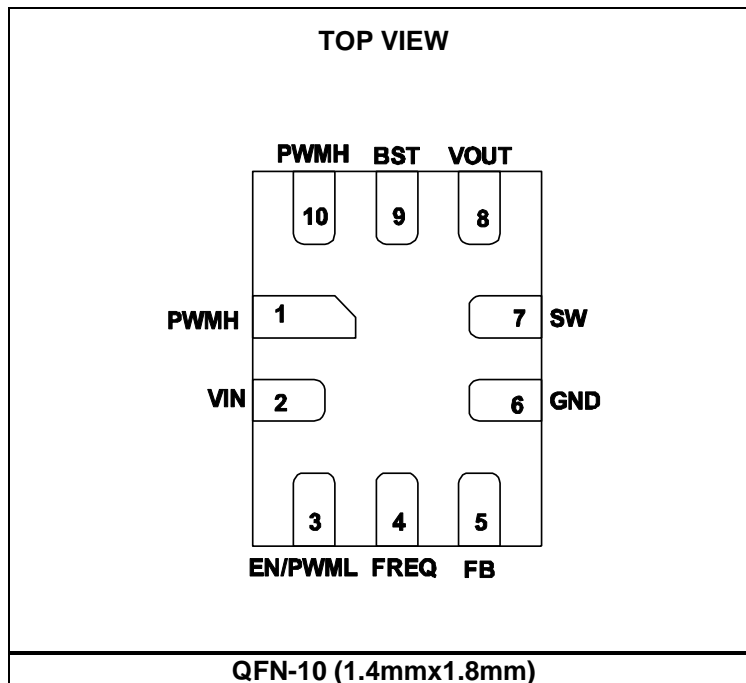

ABSOLUTE MAXIMUM RATINGS ⁽¹⁾

V _{IN}	-0.3V to +6V
V _{SW} , V _{OUT}	-1V to +40V
V _{BST}	-0.3V to V _{SW} +6V
All Other Pins	-0.3V to +6V
Junction Temperature	150°C
Lead Temperature	260°C
Continuous Power Dissipation (T _A = 25°C) ⁽²⁾	
QFN-10 (1.4mm×1.8mm).....	0.892W

Recommended Operating Conditions ⁽³⁾

Supply Voltage V _{IN}	2.7V to 5.5V
Operating Junction Temp. (T _J). -40°C to +125°C	

Thermal Resistance ⁽⁴⁾	θ_{JA}	θ_{JC}	
QFN-10 (1.4mm×1.8mm)	140.....	30	°C/W

Notes:

- 1) Exceeding these ratings may damage the device.
- 2) The maximum allowable power dissipation is a function of the maximum junction temperature T_J (MAX), the junction-to-ambient thermal resistance θ_{JA}, and the ambient temperature T_A. The maximum allowable continuous power dissipation at any ambient temperature is calculated by P_D (MAX) = (T_J (MAX)-T_A)/θ_{JA}. Exceeding the maximum allowable power dissipation will cause excessive die temperature, and the regulator will go into thermal shutdown. Internal thermal shutdown circuitry protects the device from permanent damage.
- 3) The device is not guaranteed to function outside of its operating conditions.
- 4) Measured on JESD51-7, 4-layer PCB.

ELECTRICAL CHARACTERISTICS

$V_{IN} = 3.6V$, $V_{EN} = V_{IN}$, $T_A = 25^\circ C$, unless otherwise noted.

Parameters	Symbol	Condition	Min	Typ	Max	Units
STEP-UP CONVERTER						
Operating Input Voltage	V_{IN}		2.7		5.5	V
Supply Current (Quiescent)	I_Q	$V_{IN}=3.6V$, $V_{EN}=V_{IN}$, no load with switching		420		μA
Supply Current (Shutdown)	I_{ST}	$V_{EN}=0V$, $V_{IN}=3.6V$			1	μA
		EN Bit=0, $V_{IN}=3.6V$		68		μA
Input UVLO Threshold	V_{IN_UVLO}	Rising Edge		2.5		V
Input UVLO Hysteresis				200		mV
EN High Voltage	V_{EN_HIGH}	V_{EN} Rising	1.2			V
EN Low Voltage	V_{EN_LOW}	V_{EN} Falling			0.4	V
Switching Frequency	f_{sw}	$R_{OSC} = 200k\Omega$	540	640	740	kHz
Maximum Duty Cycle	D_{MAX}	Sync Mode, 600kHz	89	93		%
		Non-sync Mode, 600kHz	90	95		
Feedback Regulation Voltage	V_{REF}		198	200	202	mV
VREF Ramp-Up Time	t_{STEP}			320		μs
POWER SWITCH						
Main Switch On-Resistance	$R_{DS(on)_M}$	$V_{IN}=3.6V$		0.3	0.5	Ω
Sync Switch On-Resistance	$R_{DS(on)_S}$	$V_{IN}=3.6V$		0.5	0.8	Ω
CURRENT DIMMING						
PWMH Input Low Threshold	V_{PWM_LO}	V_{PWM} Falling	0.4			V
PWMH Input High Threshold	V_{PWM_HI}	V_{PWM} Rising			1.2	V
PWML Shutdown Time	t_{SD}	EN/PWML High to Low		20		ms
PROTECTION						
OVP Voltage	V_{OVP}	OVP	22.5	24	25.5	V
		Hysteresis		2		V
Cycle-Cycle Current Limit	I_{LIM}		1.1	1.6		A
Startup Current Limit	I_{LIM_START}	Max Duty Cycle		0.85		A
Time Step for Half Current Limit	T_{LIM_HALF}			5		ms
OVP UVLO Threshold	V_{OVP_UV}			1.24		V
Thermal Shutdown Threshold	t_{ST}			150		$^\circ C$
Thermal Shutdown Hysteresis				25		$^\circ C$

TYPICAL PERFORMANCE CHARACTERISTICS

$V_{IN} = 3.6V$, 7 LEDs, $L = 10\mu H$, $T_A = 25^\circ C$, unless otherwise noted.

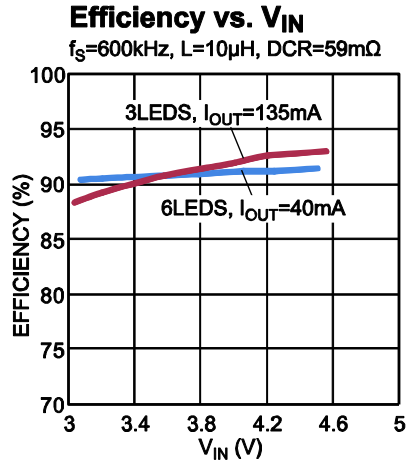

Steady State

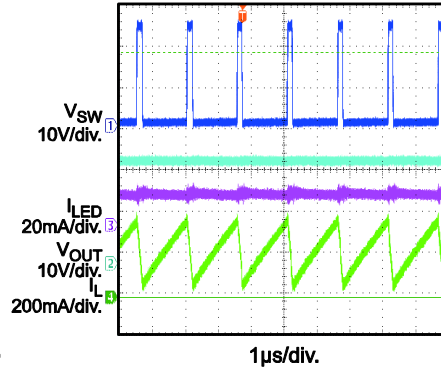

V_{IN} Power On

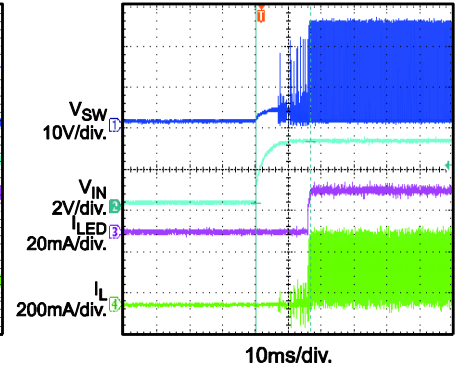

EN Power On

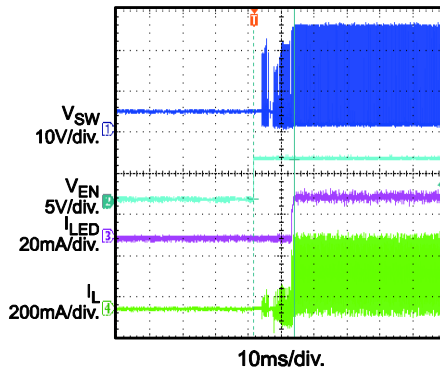

PWM Dimming

$f_{DIM} = 200Hz$, $D_{DIM} = 50\%$

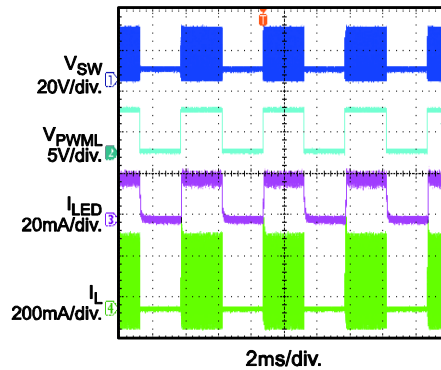

Analog Dimming

$f_{DIM} = 20kHz$, $D_{DIM} = 90\%$

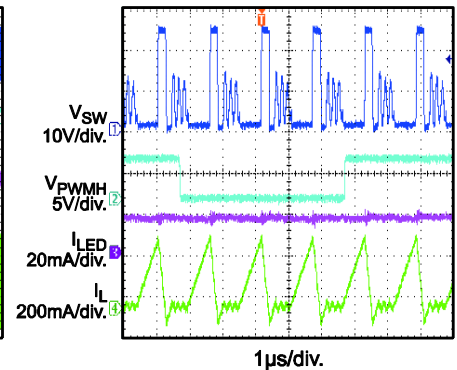

Open LED Protection

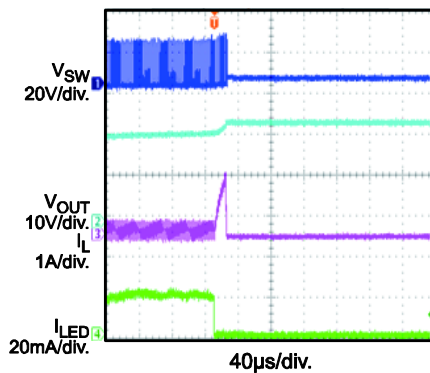

PIN FUNCTIONS

Pin #	Name	Description
1, 10	PWMH	Analog Dimming Input. >20kHz PWM signal is recommended if using a PWM signal input for analog dimming.
2	VIN	Input Supply Pin. Provides power for internal power and logic circuits. Must be locally bypassed.
3	EN/PWML	PWM Brightness Control/Enable. Apply a PWM signal for PWM dimming. The LED current dimming ratio is proportional to the PWM frequency—a lower dimming frequency results in a smaller dimming current. For most applications, use a frequency range of 200Hz to 2kHz. A low-level signal longer than 20ms will shutdown the IC.
4	FREQ	Switching Frequency Set. Connect a resistor between this pin and GND to program the converter switching frequency. Do not leave this pin floating.
5	FB	LED Current Feedback. Regulates the voltage across the current sense resistor between FB and GND to 200mV.
6	GND	Ground.
7	SW	Power Switch Node. Drain of the internal low-side MOSFET. Connect the power inductor between SW and VIN pin.
8	VOUT	Output Voltage. Internally connected to the source of the synchronous MOSFET.
9	BST	Booststrap. Connect a capacitor between SW and BST pin to provide the synchronous MOSFET gate driver.

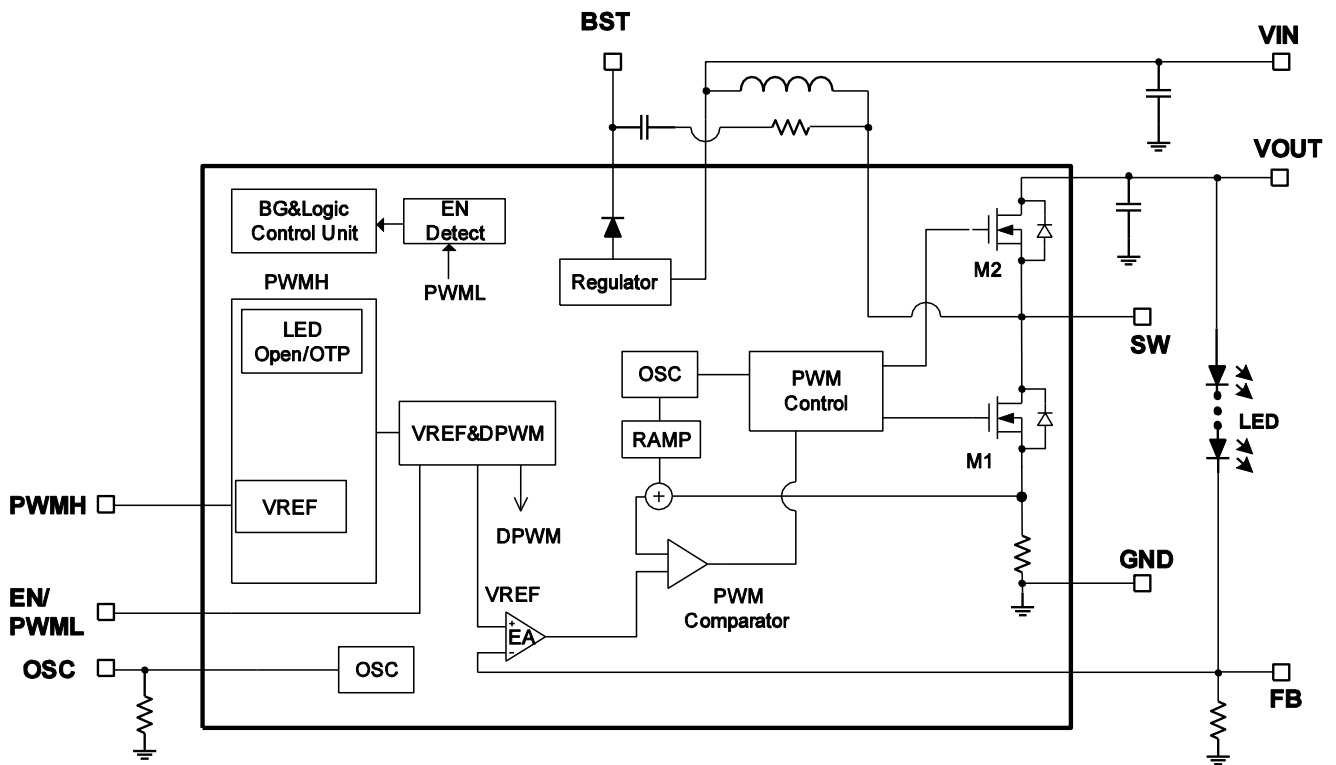

Figure 1: Functional Block Diagram

OPERATION

The MP3309L uses peak-current-mode control to regulate the current through the WLED string. At the start of each oscillator cycle, the control circuit turns on the low-side MOSFET (LS-FET, M1). A stabilizing ramp added to the output of the current-sense amplifier, which then feeds into the positive input of the PWM comparator, prevents sub-harmonic oscillations at duty cycles greater than 50%. When the input to the PWM comparator equals the output voltage of the error amplifier, M1 turns off. Then the inductor current flows through the synchronous power MOSFET, which forces the inductor current to decrease.

The voltage at the output of the error amplifier is the amplified difference between the 200mV reference voltage and the feedback voltage. If the feedback voltage starts to drop, the output of the error amplifier increases, increasing the current flowing through the M1, thus increasing the power to the inductor and output power. This method accurately regulates the LED current.

System Startup

When enabled, The MP3309L checks safety limits, including UVLO and over-temperature protection (OTP), over-current protection. If all the protection tests pass, the chip then starts boosting the step-up converter with an internal soft-start. During the soft-start, the current limit drops to 0.85A during startup to prevent a large inrush current. This low-current-limit time lasts for 5ms after the IC is enabled.

Dimming Control

The MP3309L provides two dimming methods: PWM and analog dimming mode.

For PWM dimming, apply a PWM signal to the EN/PWML pin. The LED current is then segmented as per the PWM signal and the average LED current equals:

$$I_{\text{set}} \times D_{\text{dim}}$$

Where D_{dim} is the PWM duty cycle, and I_{set} is the LED current amplitude. When PWM signal is high, the converter operates in normal mode. Conversely, when the PWM amplitude is low, the converter stops switching. Make sure that the PWM-signal low-level time is less than 20ms or the IC will shutdown. Use a 100Hz-to-2kHz PWM-dimming frequency for most dimming ratio requests.

For analog dimming, connect the PWM dimming signal on PWMH pin, an internal RC filter filters the PWM signal. The LED current amplitude equals $I_{\text{set}} \times D_{\text{dim}}$, where D_{dim} is the PWM duty cycle and I_{set} is the LED current amplitude. Use a >20kHz PWM signal to improve filtering performance.

Open-String Protection

The MP3309L monitors the VOUT pin for open-string protection. If the LED string is open, the feedback voltage is lower than the reference voltage. The COMP then rises and charges the output capacitor until the VOUT voltage reaches the protection point, V_{OVP} .

The IC stops switching when V_{OUT} reaches the OVP threshold, the IC resumes function when V_{OUT} drops below the threshold.

Input Under-Voltage Protection

When V_{IN} exceeds 2.5V, the converter starts to charge the internal reference and provides power to the internal control circuitry. There is UVLO hysteresis, approximately 200mV, as V_{IN} falls. The IC shuts down when the input voltage drops below 2.3V.

Thermal-Shutdown Protection

Thermal shutdown prevents the IC from operating at exceedingly high temperatures. When the die temperature exceeds the upper threshold (T_{ST}), the IC shutdowns and resumes normal operation when the die temperature drops below lower threshold. Typically, the hysteresis is 25°C.

APPLICATION INFORMATION

Selecting the Switching Frequency

The switching frequency of the step-up converter can be programmed from 300kHz to 1.2MHz. A resistor on the OSC pin sets the internal oscillator frequency for the step-up converter as per the equation below:

$$f_{sw}(\text{kHz}) = \frac{120000}{R_{OSC}(\text{k}\Omega)}$$

For instance, if $R_{OSC}=200\text{k}\Omega$, the switching frequency is to 600kHz.

Setting the LED Current

Set the LED current through the current-setting resistor on the FB pin.

$$I_{LED}(\text{mA}) = \frac{V_{REF}(\text{V})}{R_{FB}(\Omega)} \times 1000$$

For instance, if $V_{REF}=200\text{mV}$, and $R_{FB}=10\Omega$, the LED current is 20mA. Do not leave the FB pin floating.

Selecting the Input Capacitor

The input capacitor reduces the surge current drawn from the input supply and the switching noise from the device. The input capacitor impedance at the switching frequency should be less than the input source impedance to prevent the high-frequency switching current from passing through to the input. Use ceramic capacitors with X5R or X7R dielectrics for their low ESR and small temperature coefficients. For most applications, use a 2.2 μF -to-10 μF ceramic capacitor.

Selecting the Inductor

The MP3309L requires an inductor to boost its output voltage. A larger value inductor results in less ripple current, lowering both the peak-inductor current and the stress on the internal N-channel MOSFET. However, the larger inductor is physically larger, has a higher series resistance, and a lower saturation current.

Choose an inductor that does not saturate under the worst-case load conditions. Select the minimum inductor value to ensure that the boost converter works in continuous-conduction

mode with high efficiency and good EMI performance.

Calculate the required inductance value using the equation:

$$L \geq \frac{\eta \times V_{OUT} \times D \times (1-D)^2}{2 \times f_{sw} \times I_{LOAD}}$$

$$D = 1 - \frac{V_{IN}}{V_{OUT}}$$

Where V_{IN} and V_{OUT} are the input and output voltages, f_{sw} is the switching frequency, I_{LOAD} is the LED load current, and η is the efficiency.

The switching current for peak-current mode. To avoid hitting the current limit, the worst-case inductor peak current should be less than 80% of the current limit, I_{LIM} .

Selecting the Output Capacitor

The output capacitor keeps the output voltage ripple small and ensures feedback loop stability. The output capacitor impedance must be low at the switching frequency. Ceramic capacitors with X7R dielectrics are recommended for their low ESR characteristics. Selection must also account for the capacitance's dependence on the voltage rating; with a DC bias voltage, the capacitor can lose as much as 50% of its capacitance at its rated voltage rating. Leave a sufficient voltage rating margin when select the component.

Too-low or too-high capacitance will cause loop instability. For most applications, select a capacitor in the range of 0.1 μF to 1 μF .

Layout Considerations

Careful attention must be paid to the PCB board layout and components placement. Proper layout of the high frequency switching path is critical to prevent noise and limit electromagnetic interference. The loop consisting of MP3309L's internal low-side MOSFET, synchronous MOSFET, and output capacitor contains a high-frequency ripple current—minimize this loop. Place the input and output capacitor should as to the IC as possible.

TYPICAL APPLICATION CIRCUITS

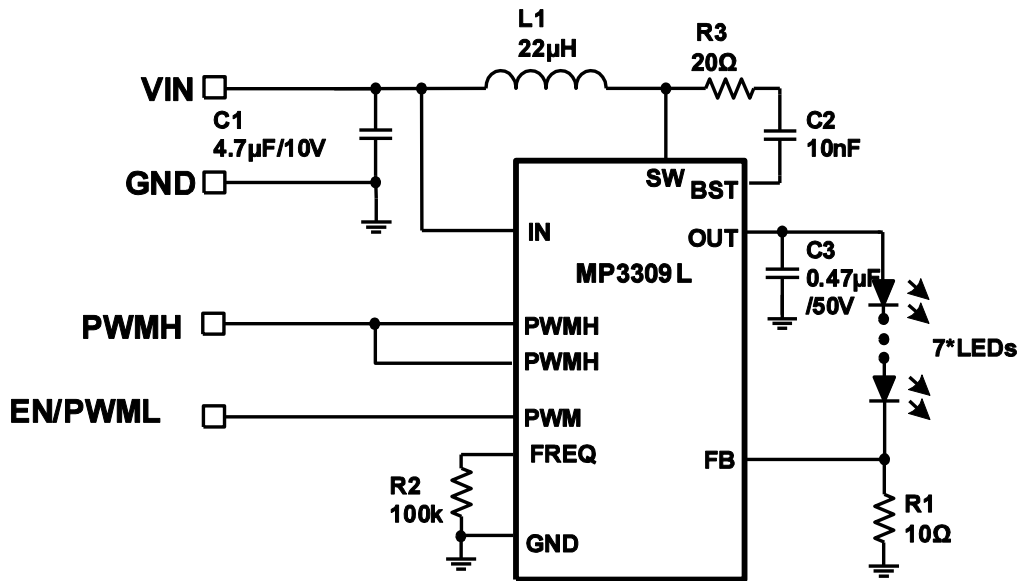

Figure 2: Typical Application for Single String 7LEDs

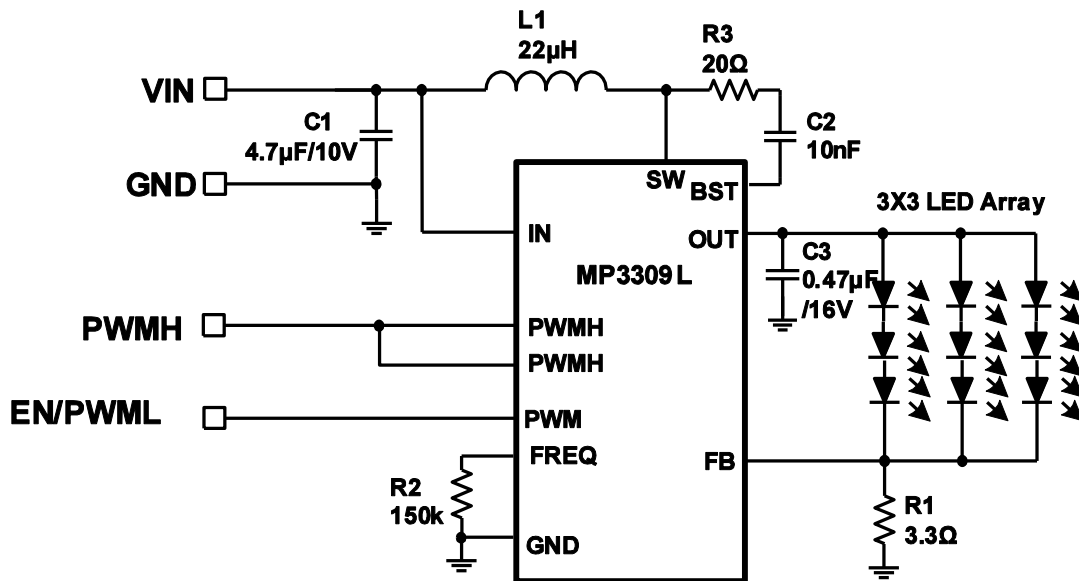

Figure 3: Typical Application for 3X3 LED Array

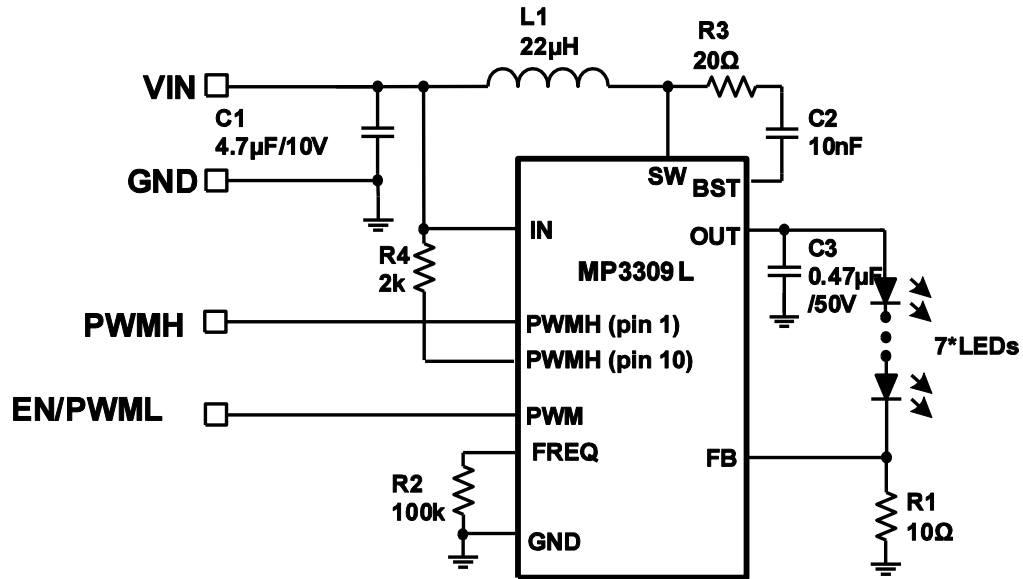
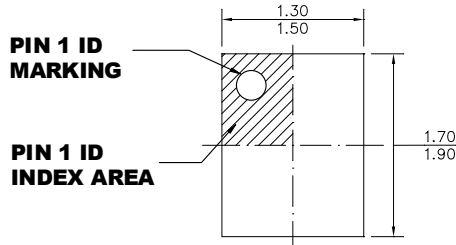

Figure 4: Typical Application for More Noise Robust Test

PACKAGE INFORMATION

QFN-10 (1.4mmx1.8mm)



TOP VIEW

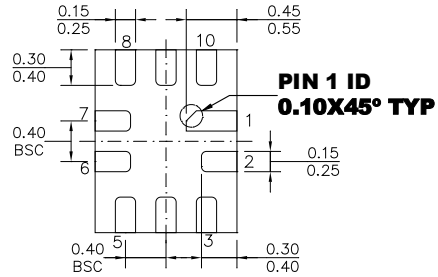

BOTTOM VIEW

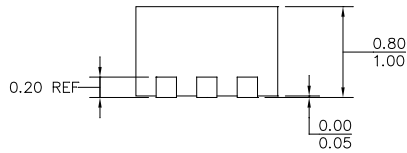

SIDE VIEW

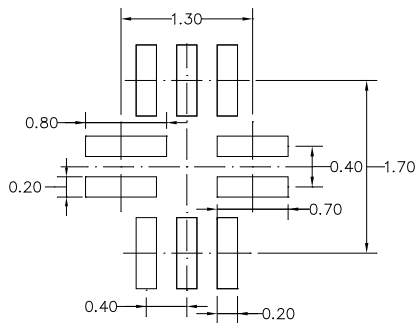

RECOMMENDED LAND PATTERN

NOTE:

- 1) ALL DIMENSIONS ARE IN MILLIMETERS.
- 2) LEAD COPLANARITY SHALL BE 0.10 MILLIMETERS MAX.
- 3) JEDEC REFERENCE IS MO-220.
- 4) DRAWING IS NOT TO SCALE.

REVISION HISTORY

Revision #	Revision Date	Description	Pages Updated
1.0	10/27/2014	Initial Release	-
1.01	7/17/2017	Added R3 to the Typical Application section	1
		Updated R3 from “0 Ω ” to “20 Ω ” in Figure 2 and Figure 3	10
		Added Figure 4 to the Typical Application Circuits section	11
		Updated “I2C&PWMH” to “PWMH” in Figure 1	7
1.1	7/25/2022	Updated the package information in the Features section	1
		Updated the package information in the Package Reference section	2
		Updated the Package Information section	12

NOTICE: The information in this document is subject to change without notice. Users should warrant and guarantee that third party Intellectual Property rights are not infringed upon when integrating MPS products into any application. MPS will not assume any legal responsibility for any said applications.