



# MLVS 1206 AM Series Specification

<b>Product Name</b>	<b>Multilayer Varistor</b>
<b>Series</b>	<b>MLVS AM Series</b>
<b>Size</b>	<b>EIA 1206</b>

## MLVS1206AM Series Engineering Specification

### Multilayer Varistor for Automotive Applications

#### 1. Scope

- (1) Qualified based on AEC-Q200
- (2) RoHS compliant
- (3) Meet IEC 61000-4-2 standard
- (4) SMD type zinc oxide based ceramic chip
- (5) Insulator over coat keeps excellent low and stable leakage current
- (6) Quick response time (<0.5ns)
- (7) High transient current capability
- (8) High reliability
- (9) Compact size for EIA1206

#### Applications

Protection against automotive related transient overvoltage

#### 2. Explanation of Part Number

<u>MLV</u>	<u>S</u>	<u>1206</u>	<u>AM</u>	<u>11</u>	<u>461</u>
(1)	(2)	(3)	(4)	(5)	(6)

1. Multilayer varistor
2. Type: S=single; A=array
3. Size
4. Automotive series
5. Max. AC voltage
6. Typical Capacitance: "150" means  $15 \times 10^0 = 15$

### 3. Construction & Dimension

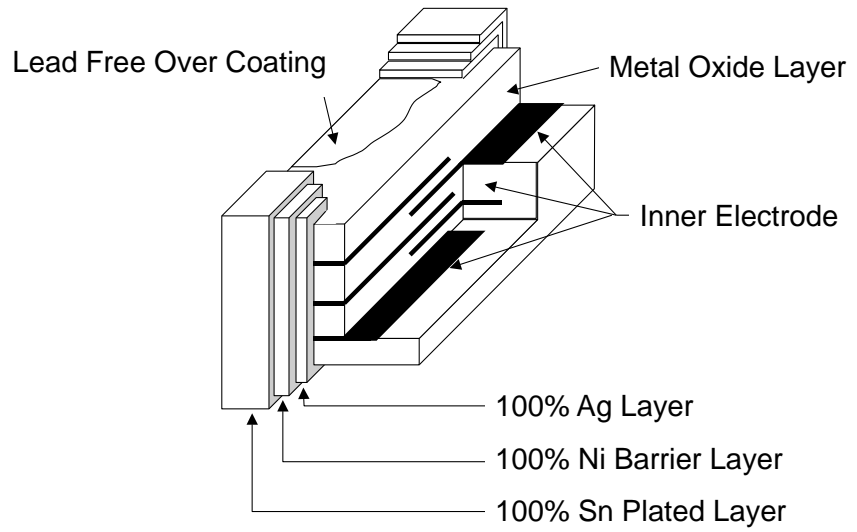
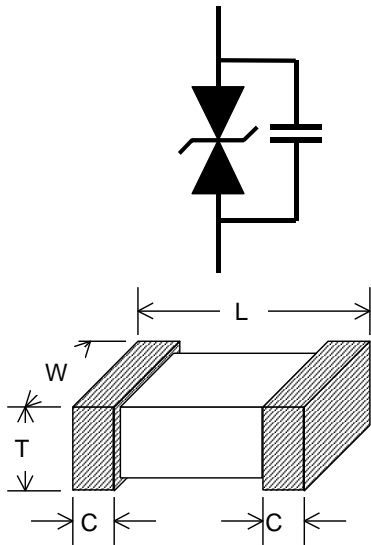

Unit: mm	1206
L	3.20±0.3
W	1.60±0.2
T	0.80±0.1
C	0.50±0.25

#### 4. Part ratings and characteristics

##### 4.1. Ratings (25°C for characteristics, 125°C for maximum ratings)

Symbol	Working voltage		Varistor voltage	Clamping Voltage	Capacitance	Peak current	Transient energy
	$V_{RMS}$	$V_{DC}$	$V_V$	$V_c$	$C_p$	$i_{max}$	$W_{max}$
Units	Volts	Volts	Volts	Volts	pF	Amps	Joules
	(Max.)	(Max.)		(Max.)	(Typical)	(Max.)	(Max.)
Test Condition		< 10 A	1mA DC	8/20 s	1KHz	8/20 s	10/1000 s
MLVS1206AM04152	4	5.5	8~13	23	1500	200	0.3
MLVS1206AM11461	11	14	18~21.6	38	460	100	0.3
MLVS1206AM11641	11	14	18~21.6	36	640	200	0.5
MLVS1206AM14801	14	16	22~28	44	800	200	0.6
MLVS1206AM14841	14	16	24.3~29.7	50	840	100	0.4
MLVS1206AM14701	14	16	19.8~25.2	42	700	200	0.5
MLVS1206AM17651	17	22	24.3~30.7	48	650	200	0.3
MLVS1206AM17841	17	22	24.3~29.7	50	840	100	0.4
MLVS1206AM20601	20	26	29.7~37.3	58	600	200	0.7
MLVS1206AM25551	25	31	35.1~43.9	69	550	200	1
MLVS1206AM30501	30	38	42.3~52.7	81	500	200	1.1
MLVS1206AM35201	35	45	54~62	108	200	200	1.1
MLVS1206AM40181	40	56	63~77	110	180	200	1.0
MLVS1206AM50251	50	65	76~92	138	250	100	0.5
MLVS1206AM60121	60	85	100~120	168	120	100	0.7

$V_{RMS}$  – Maximum AC operating voltage the varistor can maintain and not exceed 10 $\mu$ A leakage current

$V_{DC}$  – Maximum DC operating voltage the varistor can maintain and not exceed 10 $\mu$ A leakage current

$V_V$  – Voltage across the device measured at 1mA DC current.  
Equivalent to  $V_b$ , “Breakdown Voltage”.

$V_c$  – Maximum peak voltage across the varistor measured at 8/20 $\mu$ s waveform and 1A pulse current

$C_p$  – Device capacitance measured with zero volt bias 1Vrms.

$i_{max}$  – Maximum peak current which may be applied with 8/20 $\mu$ s waveform without device failure

$W_{max}$  – Maximum energy that may be dissipated with the 10/1000 $\mu$ s waveform without device failure

## 5. General electrical specifications

### 5.1. General technical data

Operating temperature	-40 ... +125°C
Storage temperature (on board)	-40 ... +125°C
Response time	<1 ns
Solderability	245±5°C, 5 +0/-0.5sec
Solder leach resistance	260±5°C, 10 ±1sec

### 5.2. Taping Package Storage Condition

Storage Time: 12 months max.

Storage Temperature: 5 to 40°C

Relative Humidity: 65% max.

## 6. Taping Package and Label Marking

### 6.1 Packaging method

Products shall be heat-sealed in chip pocket, spacing pitch 4-mm of plastic carrier tape with cover tape, and carrier tape shall be reeled to the reel.

### 6.2 Carrier tape dimensions

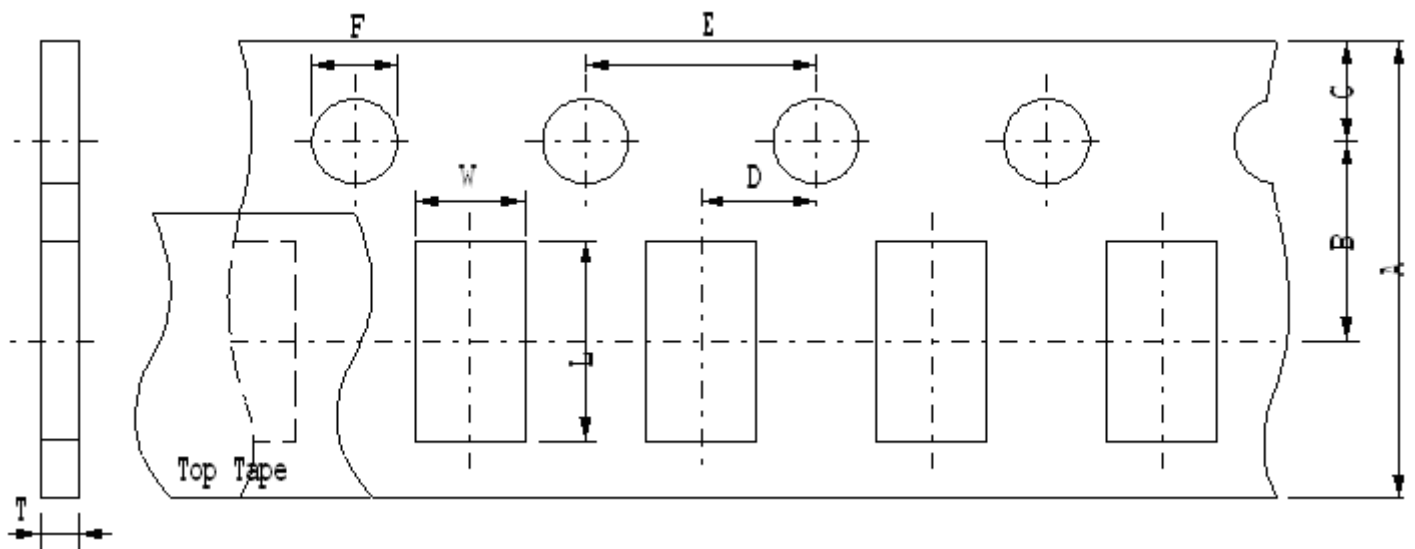

A	B	C	D	E	F	L	T	W
8.00±	3.50±	1.75±	2.00±	4.00±	1.50±	3.50±	0.95±	1.90±
0.30	0.05	0.10	0.05	0.10	0.10	0.15	0.05	0.15

### 6.3 Taping reel dimensions

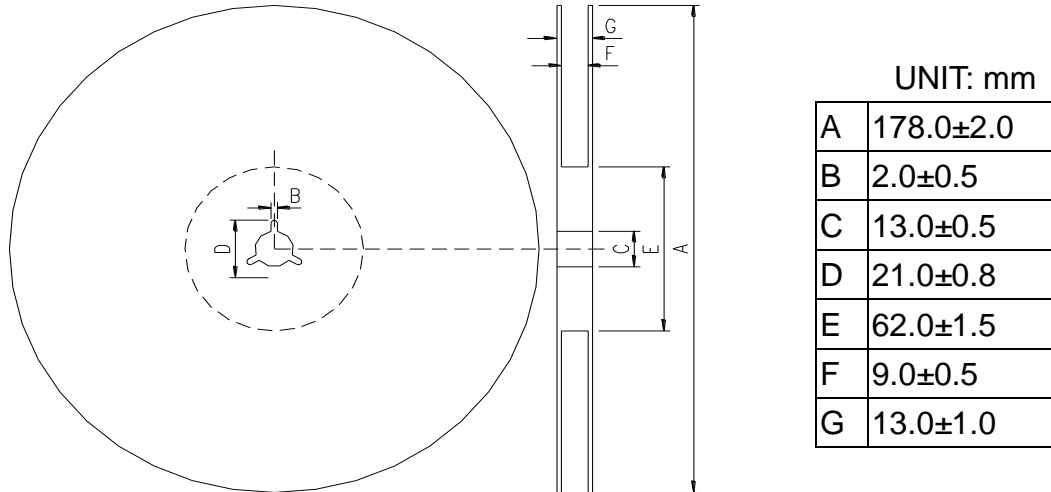

### 6.4 Taping specifications

There shall be the portion having no product in both the head and the end of taping, and there shall be the cover tape in the head of taping.

### 6.5 Label Marking

The label specified as follows shall be put on the side of reel.

- (1) Part No.
- (2) Quantity
- (3) Lot No.

Part No. And Quantity shall be marked on outer packaging.

### 6.6 Quantity of products in the taping package

- (1) Standard quantity: 4,000pcs/Reel
- (2) Shipping quantity is a multiple of standard quantity.

## 7. Precautions for Handling

### 7.1. Solder cream in reflow soldering

Refer to the recommendable land pattern as printing mask pattern for solder cream.

(1) Print solder in a thickness of 150 to 200  $\mu\text{m}$

Dimensions: millimeters (inches)

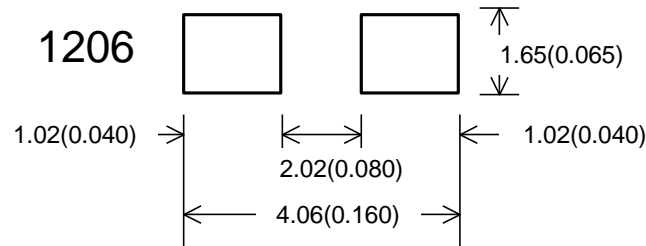

### 7.2. Precaution for handling of substrate

Do not exceed to bend the board after soldering this product extremely.

(Reference examples)

- Mounting place must be as far as possible from the position, which is close to the break line of board, or on the line of large holes of board.
- Do not bend extremely the board, in mounting another component.  
If necessary, use back-up pin (support pin) to prevent from bending extremely.
- Do not break the board by hand. We recommend using the machine or the jig to break it.

### 7.3. Precaution for soldering

Note that rapid heating, rapid cooling or local heating will easily damage the component.

Do not give heat shock over 100°C in the process of soldering. We recommend taking preheating and gradual cooling.

7.4. Recommendable reflow soldering

Profile Feature	Pb-Free Assembly
Average Ramp-Up Rate (T <sub>smax</sub> to T <sub>p</sub> )	3°C/second max.
Preheat – Temperature Min (T <sub>smin</sub> ) – Temperature Max (T <sub>smax</sub> ) – Time (t <sub>smin</sub> to t <sub>smax</sub> )	150°C 200°C 60-180 seconds
Time maintained above: – Temperature (T <sub>L</sub> ) – Time (t <sub>L</sub> )	217°C 60-150 seconds
Peak/Classification Temperature (T <sub>p</sub> )	260°C
Time within 5 °C of actual Peak Temperature (t <sub>p</sub> )	20-40 seconds
Ramp-Down Rate	6°C/second max.
Time 25 °C to Peak Temperature	8 minutes max.

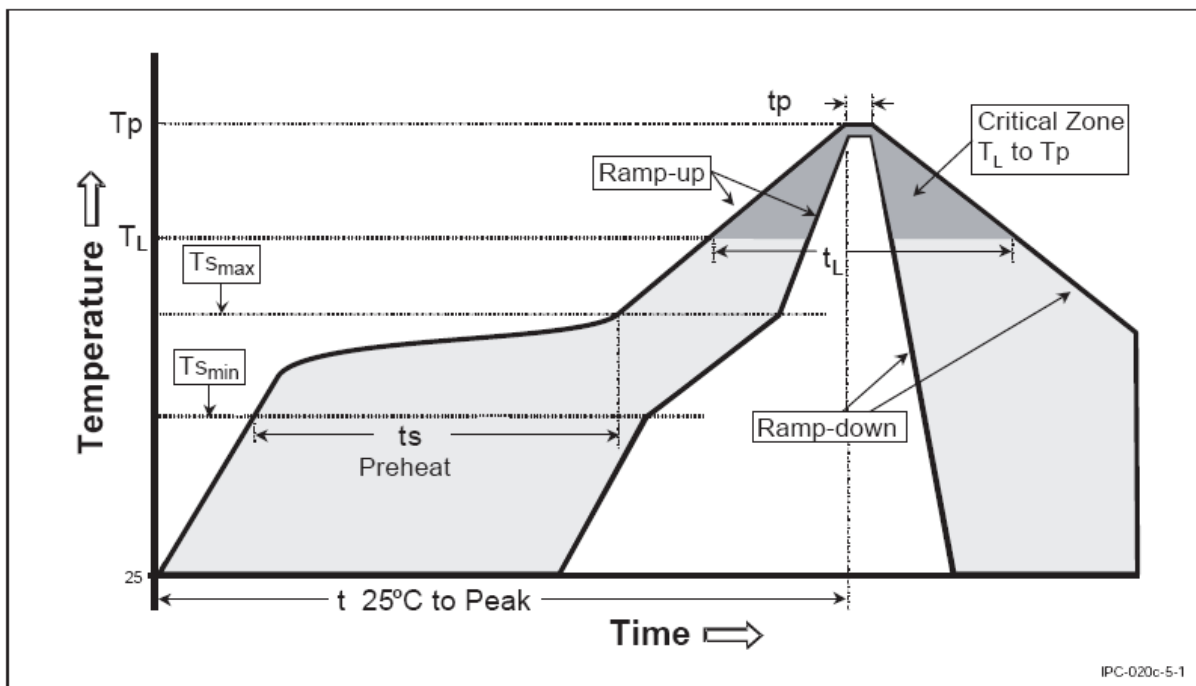

\*According to J-STD-020C



#### 7.5. Solder gun procedure

Note the follows, in case of using solder gun for replacement.

- (1) Use solder tip temperature must be less than 350°C for the period within 3 seconds by using soldering gun under 30W.
- (2) Soldering gun tip shall not touch component directly.

#### 7.6. Soldering volume

Apply proper volume of solder paste, too much may cause crack of component body.