



Low Power A/D Flash MCU with LCD Driver

HT67L2540A/HT67L2550A

Revision: V1.20 Date: August 25, 2023

www.holtek.com

Table of Contents

Features	7
CPU Features	7
Peripheral Features.....	7
General Description	8
Selection Table	9
Block Diagram	9
Pin Assignment	10
Pin Description	12
Absolute Maximum Ratings	18
D.C. Characteristics	18
Operating Voltage Characteristics.....	18
Standby Current Characteristics	19
Operating Current Characteristics.....	20
A.C. Characteristics	22
High Speed Internal Oscillator – HIRC – Frequency Accuracy	22
Middle Speed Internal Oscillator Characteristics – MIRC	23
Low Speed Internal Oscillator Characteristics – LIRC	23
Low Speed External Crystal Oscillator Characteristics – LXT	24
Operating Frequency Characteristic Curves	24
System Start Up Time Characteristics	24
Input/Output Characteristics	25
Input/Output (without Multi-power) D.C. Characteristics	25
Input/Output (with Multi-power) D.C. Characteristics	26
Memory Characteristics	27
LCD Electrical Characteristics	27
LVR/LVD Electrical Characteristics	28
Reference Voltage Characteristics	29
A/D Converter Electrical Characteristics	29
12-bit Resolution Mode	29
10-bit Resolution Mode	30
Temperature Sensor Characteristics	31
I²C Electrical Characteristics	32
Power-on Reset Characteristics	33
System Architecture	33
Clocking and Pipelining.....	33
Program Counter.....	34
Stack	36
Arithmetic and Logic Unit – ALU	37

Flash Program Memory	38
Structure.....	38
Special Vectors	38
Look-up Table.....	38
Table Program Example	39
In Circuit Programming – ICP	40
On-Chip Debug Support – OCDS	41
In Application Programming – IAP	41
Data Memory	58
Structure.....	58
Data Memory Addressing.....	59
General Purpose Data Memory	59
Special Purpose Data Memory	59
Special Function Register Description.....	62
Indirect Addressing Registers – IAR0, IAR1, IAR2	62
Memory Pointers – MP0, MP1L, MP1H, MP2L, MP2H.....	62
Accumulator – ACC.....	63
Program Counter Low Byte Register – PCL.....	64
Look-up Table Registers – TBLP, TBHP, TBLH.....	64
Option Memory Mapping Register – ORMC	64
Status Register – STATUS.....	65
EEPROM Data Memory.....	66
EEPROM Data Memory Structure	66
EEPROM Registers	66
Reading Data from the EEPROM	68
Writing Data to the EEPROM.....	69
Write Protection.....	69
EEPROM Interrupt	69
Programming Considerations.....	69
Oscillators	71
Oscillator Overview	71
System Clock Configurations	71
External Crystal/Ceramic Oscillator – HXT	72
Internal High Speed RC Oscillator – HIRC	73
Internal Middle Speed RC Oscillator – MIRC.....	73
Internal 32.768kHz Oscillator – LIRC.....	74
External 32.768kHz Crystal Oscillator – LXT	74
Operating Modes and System Clocks	75
System Clocks	75
System Operation Modes.....	76
Control Registers	78
Operating Mode Switching.....	81

Standby Current Considerations	85
Wake-up	85
Watchdog Timer	86
Watchdog Timer Clock Source	86
Watchdog Timer Control Register	86
Watchdog Timer Operation	87
Reset and Initialisation	88
Reset Functions	88
Reset Initial Conditions	92
Input/Output Ports	97
Pull-high Resistors	98
Port A Wake-up	98
I/O Port Control Registers	99
I/O Port Power Source Control	99
Pin-shared Functions	100
I/O Pin Structures	106
READ PORT Function	107
Programming Considerations	108
Timer Modules – TM	108
Introduction	108
TM Operation	109
TM Clock Source	109
TM Interrupts	109
TM External Pins	109
Programming Considerations	111
Standard Type TM – STM	112
Standard Type TM Operation	112
Standard Type TM Register Description	113
Standard Type TM Operation Modes	117
Periodic Type TM – PTM	127
Periodic TM Operation	127
Periodic Type TM Register Description	127
Periodic Type TM Operation Modes	132
Analog to Digital Converter	139
A/D Converter Overview	139
A/D Converter Register Description	140
A/D Converter Operation	143
A/D Converter Reference Voltage	144
A/D Converter Input Signals	145
Conversion Rate and Timing Diagram	145
Summary of A/D Conversion Steps	146
Programming Considerations	147
A/D Conversion Function	147

Temperature Measurement Function (For 12-bit Resolution Mode)	148
A/D Conversion Programming Examples.....	150
Universal Serial Interface Module – USIM	151
SPI Interface	151
I ² C Interface	159
UART Interface.....	168
LCD Driver	184
LCD Display Memory	184
LCD Clock Source.....	186
C-type LCD Pump Clock Source.....	186
LCD Registers.....	186
LCD Voltage Source and Biasing.....	188
LCD Reset Status	191
LCD Driver Output.....	191
Programming Considerations.....	194
Cyclic Redundancy Check – CRC	195
CRC Registers	195
CRC Operation.....	196
CRC Computation.....	196
Low Voltage Detector – LVD	198
LVD Register	198
LVD Operation.....	199
Interrupts	199
Interrupt Registers.....	199
Interrupt Operation	204
External Interrupts.....	205
A/D Converter Interrupt.....	206
Universal Serial Interface Module Interrupt.....	206
Time Base Interrupts	206
Multi-function Interrupts.....	208
EEPROM Interrupt	209
LVD Interrupt.....	209
TM Interrupts.....	209
Interrupt Wake-up Function.....	209
Programming Considerations.....	210
Configuration Options.....	210
Application Circuits.....	211
Instruction Set.....	213
Introduction	213
Instruction Timing	213
Moving and Transferring Data.....	213
Arithmetic Operations.....	213
Logical and Rotate Operation	214

Branches and Control Transfer	214
Bit Operations	214
Table Read Operations	214
Other Operations.....	214
Instruction Set Summary	215
Table Conventions.....	215
Extended Instruction Set.....	217
Instruction Definition.....	219
Extended Instruction Definition	228
Package Information	235
48-pin LQFP (7mm×7mm) Outline Dimensions	236
64-pin LQFP (7mm×7mm) Outline Dimensions	237

Features

CPU Features

- Operating voltage
 - ♦ MIRC
 - $f_{SYS}=64\text{kHz}$: 1.8V~5.5V
 - $f_{SYS}=128\text{kHz}$: 1.8V~5.5V
 - $f_{SYS}=256\text{kHz}$: 1.8V~5.5V
 - $f_{SYS}=512\text{kHz}$: 1.8V~5.5V
 - ♦ HXT
 - $f_{SYS}=1\text{MHz}$: 2.2V~5.5V
 - $f_{SYS}=2\text{MHz}$: 2.2V~5.5V
 - $f_{SYS}=4\text{MHz}$: 2.2V~5.5V
 - $f_{SYS}=8\text{MHz}$: 2.2V~5.5V
 - $f_{SYS}=12\text{MHz}$: 2.7V~5.5V
 - $f_{SYS}=16\text{MHz}$: 3.3V~5.5V
 - ♦ HIRC
 - $f_{SYS}=2\text{MHz}$: 1.8V~5.5V
 - $f_{SYS}=4\text{MHz}$: 1.8V~5.5V
 - $f_{SYS}=8\text{MHz}$: 2.2V~5.5V
- Up to 0.25 μs instruction cycle with 16MHz system clock at $V_{DD}=5\text{V}$
- Power down and wake-up functions to reduce power consumption
- Low current consumption
 - ♦ Under 0.5 μA @ 3V current of SLEEP mode, Time Base on and LIRC on
 - ♦ Operating current consumption: 350 μA @ $f_{SYS}=4\text{MHz}/3\text{V}$, HXT on
 - ♦ Operating current consumption: 3.8 μA @ $f_{SYS}=32.768\text{kHz}/3\text{V}$
- Oscillator types
 - ♦ External High Speed Crystal – HXT
 - ♦ Internal High Speed 2/4/8MHz RC – HIRC
 - ♦ Internal Middle Speed 64/128/256/512kHz RC – MIRC
 - ♦ External Low Speed 32.768kHz Crystal – LXT
 - ♦ Internal Low Speed 32.768kHz RC – LIRC
- Multi-mode operation: FAST, SLOW, IDLE and SLEEP
- Fully integrated internal oscillators require no external components
- All instructions executed in 1~3 instruction cycles
- Table read instructions
- 115 powerful instructions
- 8-level subroutine nesting
- Bit manipulation instruction

Peripheral Features

- Flash Program Memory: 4K \times 16~8K \times 16
- Data Memory: 256 \times 8~512 \times 8
- True EEPROM Memory: 256 \times 8~512 \times 8

- In Application Programming function – IAP
- Watchdog Timer function
- Up to 30 bidirectional I/O lines
- Two external interrupt lines shared with I/O pins
- Multiple Timer Modules for time measurement, input capture, compare match output, PWM output function or single pulse output function
- Universal Serial Interface Module – USIM for SPI, I²C or UART communication
- 8 channel 10/12-bit resolution A/D converter
- Temperature Sensor with internal reference voltage
- Integrated 16-bit Cyclic Redundancy Check function – CRC
- LCD driver function
 - ♦ SEGs×COMs: 24×4 for HT67L2540A
 - ♦ SEGs×COMs: 32×4 for HT67L2550A
 - ♦ Duty type: 1/4 duty
 - ♦ Bias level: 1/3 bias
 - ♦ Bias type: R type or C type
 - ♦ Waveform type: type A or type B
- Dual Time Base functions for generation of fixed time interrupt signals
- Low voltage reset function
- Low voltage detect function
- Package types: 48/64-pin LQFP

General Description

The series of devices are Flash Memory A/D type 8-bit high performance RISC architecture microcontrollers with LCD driver, designed for applications that interface directly to analog signals and LCD display products.

For memory features, the Flash Memory offers users the convenience of multi-programming features. Other memory includes an area of RAM Data Memory as well as an area of EEPROM memory for storage of non-volatile data such as serial numbers, calibration data etc. By using the In Application Programming technology, user have a convenient means to directly store their measured data in the Flash Program Memory as well as having the ability to easily update their application programs.

Analog features include a multi-channel 10/12-bit A/D converter with an integrated temperature sensor circuitry and a LCD driver. Multiple and extremely flexible Timer Modules provide timing, pulse generation and PWM generation functions. Communication with the outside world is catered for by including fully integrated SPI, I²C and UART interface functions, three popular interfaces which provide designers with a means of easy communication with external peripheral hardware. Protective features such as an internal Watchdog Timer, Low Voltage Reset and Low Voltage Detector coupled with excellent noise immunity and ESD protection ensure that reliable operation is maintained in hostile electrical environments.

A full choice of external, internal high and low speed oscillators is provided including three fully integrated system oscillators which require no external components for their implementation. The ability to operate and switch dynamically between a range of operating modes using different clock sources gives users the ability to optimise microcontroller operation and minimise power consumption.

The inclusion of flexible I/O programming features, Time Base functions along with many other features ensure that the devices will find excellent use in applications such as electronic metering, environmental monitoring in addition to many others.

Selection Table

Most features are common to these devices, the main features distinguishing them are Program Memory capacity, Data Memory capacity, I/O count, Timer Module, LCD display count and package types. The following table summarises the main features of each device.

Part No.	V _{DD}	Program Memory	Data Memory	Data EEPROM	I/O	Time Base	Stack	Timer Module
HT67L2540A	1.8V~5.5V	4K×16	256×8	256×8	22	2	8	16-bit STM×1 16-bit PTM×1
HT67L2550A	1.8V~5.5V	8K×16	512×8	512×8	30	2	8	16-bit STM×1 16-bit PTM×2

Part No.	Ext. Int.	A/D Converter	LCD	LVD/LVR	USIM	CRC	Package
HT67L2540A	2	10/12-bit×8	24×4	√	√	√	48LQFP
HT67L2550A	2	10/12-bit×8	32×4	√	√	√	48/64LQFP

Block Diagram

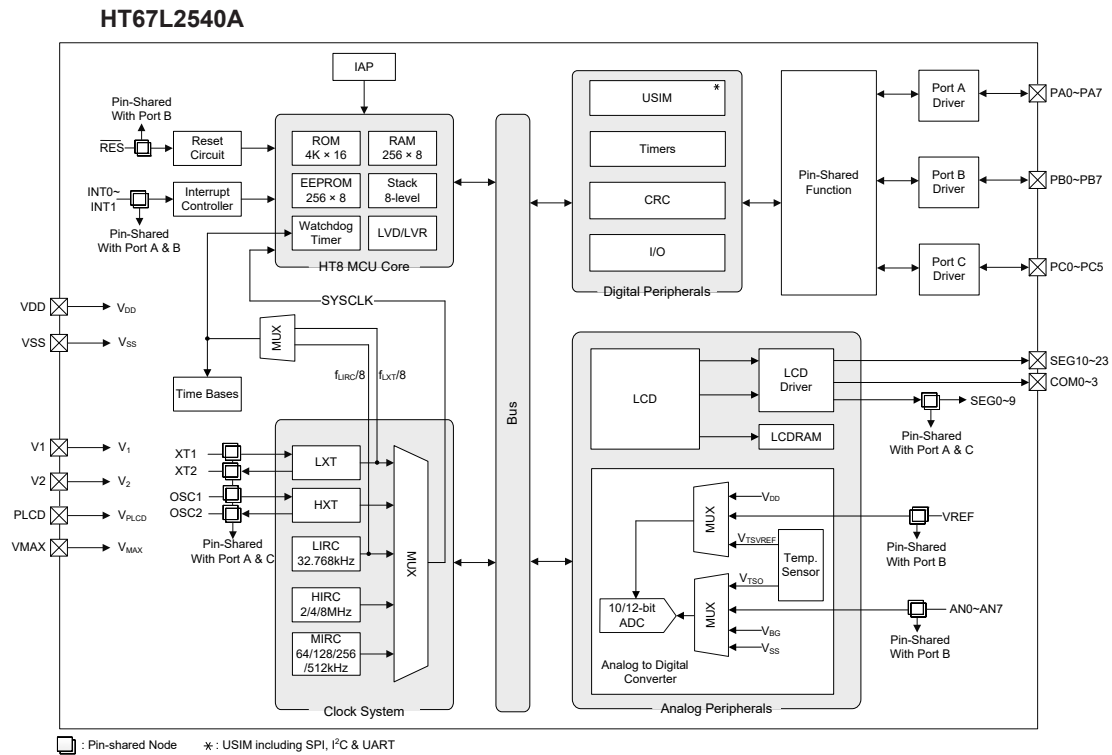

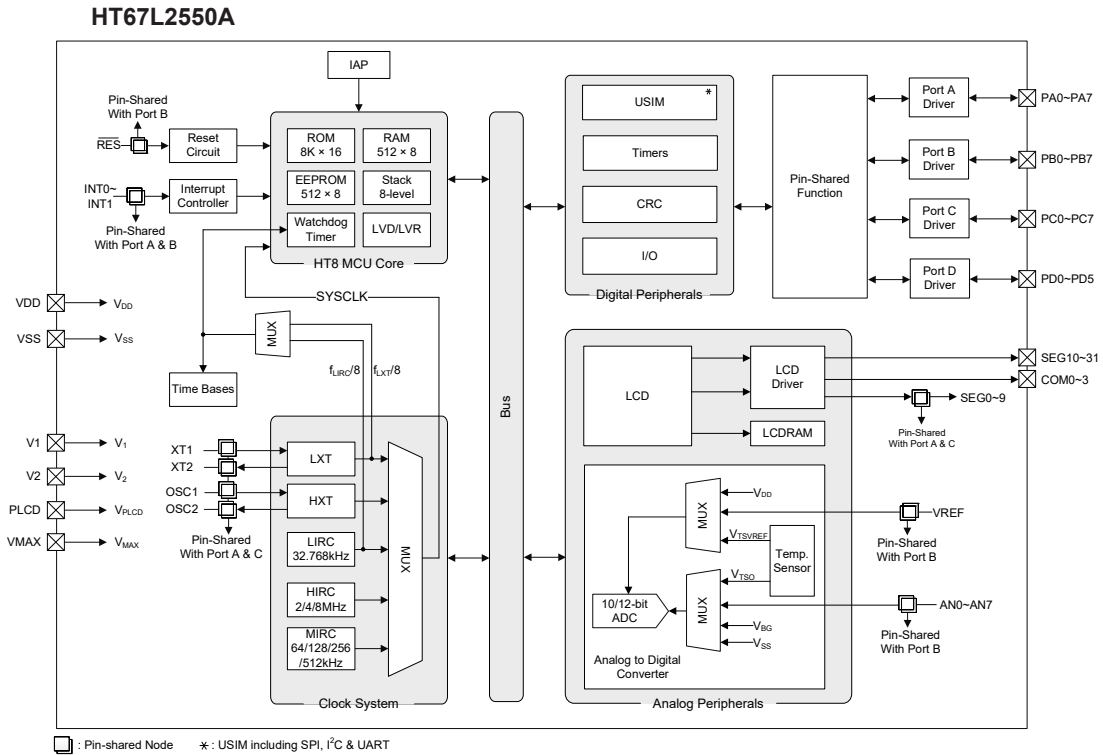

Pin Assignment

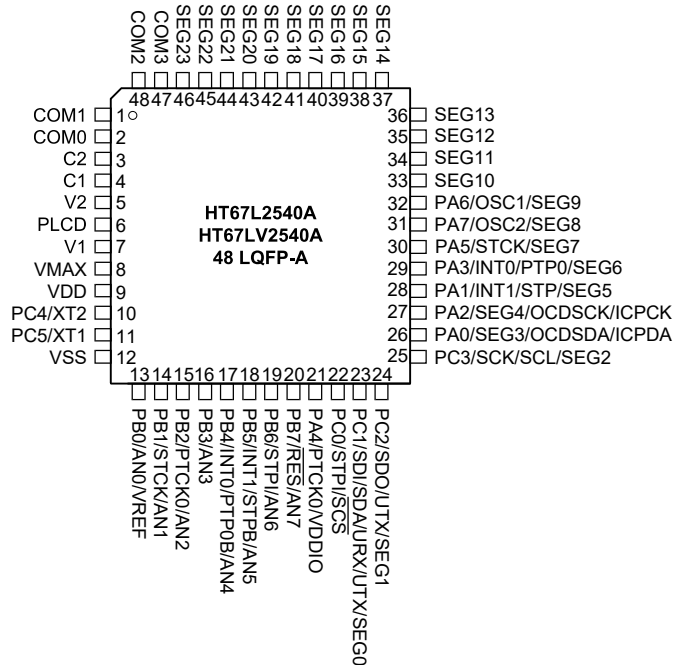

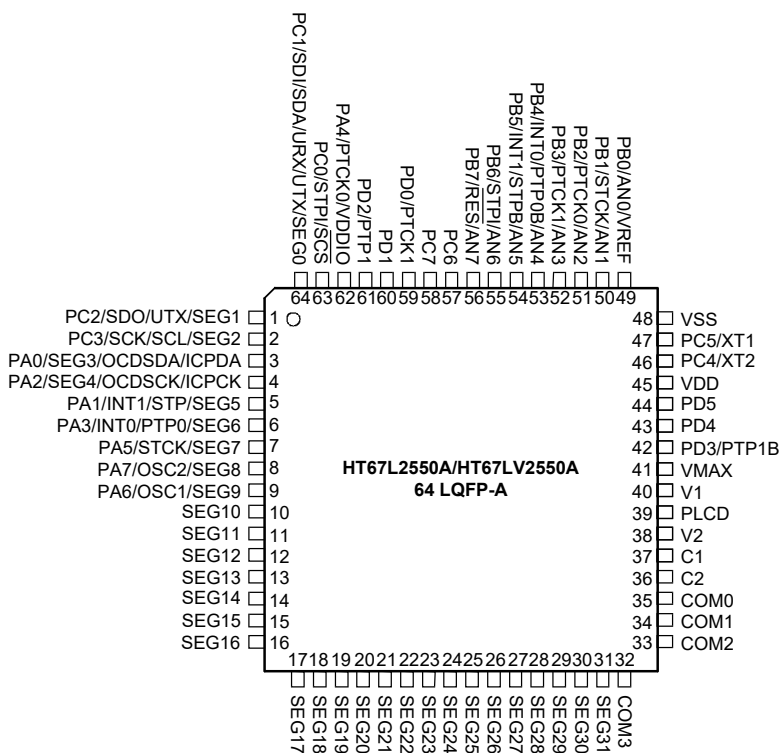
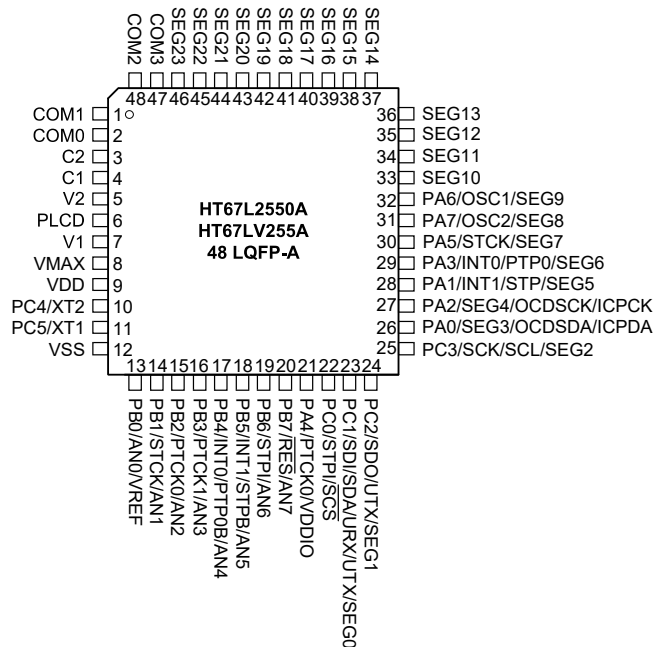

- Note: 1. If the pin-shared pin functions have multiple outputs, the desired pin-shared function is determined by the corresponding software control bits.
2. The OCSDA and OCDSCK pins are the OCDS dedicated pins and only available for the HT67LV2540A/HT67LV2550A device which is the OCDS EV chip for the HT67L2540A/HT67L2550A device.
3. For the less pin count package type there will be unbounded pins which should be properly configured to avoid unwanted power consumption resulting from floating input conditions. Refer to the “Standby Current Considerations” and “Input/Output Ports” sections.

Pin Description

The function of each pin is listed in the following table, however the details behind how each pin is configured is contained in other sections of the datasheet. As each Pin Description table shows the situation for the package with the most pins, not all pins in the table will be available on smaller package sizes.

HT67L2540A

Pin Name	Function	OPT	I/T	O/T	Description
PA0/SEG3/ICPDA/OCDSDA	PA0	PAPU PAWU PAS0	ST	CMOS	General purpose I/O. Register enabled pull-high and wake-up
	SEG3	PAS0	—	AN	LCD segment output
	ICPDA	—	ST	CMOS	ICP data/address
	OCDSDA	—	ST	CMOS	OCDS data/address, for EV chip only
PA1/INT1/STP/SEG5	PA1	PAPU PAWU PAS0	ST	CMOS	General purpose I/O. Register enabled pull-high and wake-up
	INT1	PAS0 INTEG INTC0 IFS2	ST	—	External Interrupt 1 input
	STP	PAS0	—	CMOS	STM output
	SEG5	PAS0	—	AN	LCD segment output
PA2/SEG4/ICPCK/OCDSCK	PA2	PAPU PAWU PAS0	ST	CMOS	General purpose I/O. Register enabled pull-high and wake-up
	SEG4	PAS0	—	AN	LCD segment output
	ICPCK	—	ST	—	ICP clock pin
	OCDSCK	—	ST	—	OCDS clock pin, for EV chip only
PA3/INT0/PTP0/SEG6	PA3	PAPU PAWU PAS0	ST	CMOS	General purpose I/O. Register enabled pull-high and wake-up
	INT0	PAS0 INTEG INTC0 IFS2	ST	—	External Interrupt 0 input
	PTP0	PAS0	—	CMOS	PTM0 output
	SEG6	PAS0	—	AN	LCD segment output
PA4/PTCK0/VDDIO	PA4	PAPU PAWU PAS1	ST	CMOS	General purpose I/O. Register enabled pull-high and wake-up
	PTCK0	PAS1 IFS0	ST	—	PTM0 clock input
	VDDIO	PAS1	PWR	—	PC0~PC3 pin power supply
PA5/STCK/SEG7	PA5	PAPU PAWU PAS1	ST	CMOS	General purpose I/O. Register enabled pull-high and wake-up
	STCK	PAS1 IFS0	ST	—	STM clock input
	SEG7	PAS1	—	AN	LCD segment output

Pin Name	Function	OPT	I/T	O/T	Description
PA6/OSC1/SEG9	PA6	PAPU PAWU PAS1	ST	CMOS	General purpose I/O. Register enabled pull-high and wake-up
	OSC1	PAS1	AN	—	HXT oscillator pin
	SEG9	PAS1	—	AN	LCD segment output
PA7/OSC2/SEG8	PA7	PAPU PAWU PAS1	ST	CMOS	General purpose I/O. Register enabled pull-high and wake-up
	OSC2	PAS1	—	AN	HXT oscillator pin
	SEG8	PAS1	—	AN	LCD segment output
PB0/AN0/VREF	PB0	PBPU PBS0	ST	CMOS	General purpose I/O. Register enabled pull-high
	AN0	PBS0	AN	—	A/D Converter analog input
	VREF	PBS0	AN	—	A/D Converter reference voltage input
PB1/STCK/AN1	PB1	PBPU PBS0	ST	CMOS	General purpose I/O. Register enabled pull-high
	STCK	PBS0 IFS0	ST	—	STM clock input
	AN1	PBS0	AN	—	A/D Converter analog input
PB2/PTCK0/AN2	PB2	PBPU PBS0	ST	CMOS	General purpose I/O. Register enabled pull-high
	PTCK0	PBS0 IFS0	ST	—	PTM0 clock input
	AN2	PBS0	AN	—	A/D Converter analog input
PB3/AN3	PB3	PBPU PBS0	ST	CMOS	General purpose I/O. Register enabled pull-high
	AN3	PBS0	AN	—	A/D Converter analog input
PB4/INT0/PTP0B/AN4	PB4	PBPU PBS1	ST	CMOS	General purpose I/O. Register enabled pull-high
	INT0	PBS1 INTEG INTC0 IFS2	ST	—	External Interrupt 0 input
	PTP0B	PBS1	—	CMOS	PTM0 inverted output
	AN4	PBS1	AN	—	A/D Converter analog input
PB5/INT1/STPB/AN5	PB5	PBPU PBS1	ST	CMOS	General purpose I/O. Register enabled pull-high
	INT1	PBS1 INTEG INTC0 IFS2	ST	—	External Interrupt 1 input
	STPB	PBS1	—	CMOS	STM inverted output
	AN5	PBS1	AN	—	A/D Converter analog input
PB6/STPI/AN6	PB6	PBPU PBS1	ST	CMOS	General purpose I/O. Register enabled pull-high
	STPI	PBS1 IFS1	ST	—	STM capture input
	AN6	PBS1	AN	—	A/D Converter analog input
PB7/ $\overline{\text{RES}}$ /AN7	PB7	PBPU PBS1	ST	CMOS	General purpose I/O. Register enabled pull-high
	$\overline{\text{RES}}$	PBS1	ST	—	Reset pin
	AN7	PBS1	AN	—	A/D Converter analog input

Pin Name	Function	OPT	I/T	O/T	Description
PC0/STPI/SCS	PC0	PCPU PCS0	ST	CMOS	General purpose I/O. Register enabled pull-high
	STPI	PCS0 IFS1	ST	—	STM capture input
	SCS	PCS0	ST	CMOS	SPI slave select
PC1/SDI/SDA/URX/UTX/ SEG0	PC1	PCPU PCS0	ST	CMOS	General purpose I/O. Register enabled pull-high
	SDI	PCS0	ST	—	SPI serial data input
	SDA	PCS0	ST	NMOS	I ² C data line
	URX/UTX	PCS0	ST	CMOS	UART serial data input in full-duplex communication or UART serial data input / output in Single Wire Mode communication
	SEG0	PCS0	—	AN	LCD segment output
PC2/SDO/UTX/SEG1	PC2	PCPU PCS0	ST	CMOS	General purpose I/O. Register enabled pull-high
	SDO	PCS0	—	CMOS	SPI serial data output
	UTX	PCS0	—	CMOS	UART serial data output
	SEG1	PCS0	—	AN	LCD segment output
PC3/SCK/SCL/SEG2	PC3	PCPU PCS0	ST	CMOS	General purpose I/O. Register enabled pull-high
	SCK	PCS0	ST	CMOS	SPI serial clock
	SCL	PCS0	ST	NMOS	I ² C clock line
	SEG2	PCS0	—	AN	LCD segment output
PC4/XT2	PC4	PCPU PCS1	ST	CMOS	General purpose I/O. Register enabled pull-high
	XT2	PCS1	—	AN	LXT oscillator pin
PC5/XT1	PC5	PCPU PCS1	ST	CMOS	General purpose I/O. Register enabled pull-high
	XT1	PCS1	AN	—	LXT oscillator pin
SEG10~SEG23	SEGn	—	—	AN	LCD segment output
COM0~COM3	COMn	—	—	AN	LCD common output
VMAX	VMAX	—	PWR	—	IC maximum voltage, connect to VDD or V1
PLCD	PLCD	—	PWR	AN	LCD power supply
V1	V1	—	PWR	AN	LCD power supply
V2	V2	—	PWR	AN	LCD power supply
C1	C1	—	—	AN	LCD voltage pump
C2	C2	—	—	AN	LCD voltage pump
VDD	VDD	—	PWR	—	Positive power supply
VSS	VSS	—	PWR	—	Negative power supply

Legend: I/T: Input type;

OPT: Optional by register option;

ST: Schmitt Trigger input;

NMOS: NMOS output;

O/T: Output type;

PWR: Power;

CMOS: CMOS output;

AN: Analog signal

HT67L2550A

Pin Name	Function	OPT	I/T	O/T	Description
PA0/SEG3/ICPDA/OCSDA	PA0	PAPU PAWU PAS0	ST	CMOS	General purpose I/O. Register enabled pull-high and wake-up
	SEG3	PAS0	—	AN	LCD segment output
	ICPDA	—	ST	CMOS	ICP data/address
	OCSDA	—	ST	CMOS	OCDS data/address, for EV chip only
PA1/INT1/STP/SEG5	PA1	PAPU PAWU PAS0	ST	CMOS	General purpose I/O. Register enabled pull-high and wake-up
	INT1	PAS0 INTEG INTC0 IFS2	ST	—	External Interrupt 1 input
	STP	PAS0	—	CMOS	STM output
	SEG5	PAS0	—	AN	LCD segment output
PA2/SEG4/ICPCK/OCDSCK	PA2	PAPU PAWU PAS0	ST	CMOS	General purpose I/O. Register enabled pull-high and wake-up
	SEG4	PAS0	—	AN	LCD segment output
	ICPCK	—	ST	—	ICP clock pin
	OCDSCK	—	ST	—	OCDS clock pin, for EV chip only
PA3/INT0/PTP0/SEG6	PA3	PAPU PAWU PAS0	ST	CMOS	General purpose I/O. Register enabled pull-high and wake-up
	INT0	PAS0 INTEG INTC0 IFS2	ST	—	External Interrupt 0 input
	PTP0	PAS0	—	CMOS	PTM0 output
	SEG6	PAS0	—	AN	LCD segment output
PA4/PTCK0/VDDIO	PA4	PAPU PAWU PAS1	ST	CMOS	General purpose I/O. Register enabled pull-high and wake-up
	PTCK0	PAS1 IFS0	ST	—	PTM0 clock input
	VDDIO	PAS1	PWR	—	PC0~PC3 pin power supply
PA5/STCK/SEG7	PA5	PAPU PAWU PAS1	ST	CMOS	General purpose I/O. Register enabled pull-high and wake-up
	STCK	PAS1 IFS0	ST	—	STM clock input
	SEG7	PAS1	—	AN	LCD segment output
PA6/OSC1/SEG9	PA6	PAPU PAWU PAS1	ST	CMOS	General purpose I/O. Register enabled pull-high and wake-up
	OSC1	PAS1	AN	—	HXT oscillator pin
	SEG9	PAS1	—	AN	LCD segment output
PA7/OSC2/SEG8	PA7	PAPU PAWU PAS1	ST	CMOS	General purpose I/O. Register enabled pull-high and wake-up
	OSC2	PAS1	—	AN	HXT oscillator pin
	SEG8	PAS1	—	AN	LCD segment output

Pin Name	Function	OPT	I/T	O/T	Description
PB0/AN0/VREF	PB0	PBPU PBS0	ST	CMOS	General purpose I/O. Register enabled pull-high
	AN0	PBS0	AN	—	A/D Converter analog input
	VREF	PBS0	AN	—	A/D converter reference voltage input
PB1/STCK/AN1	PB1	PBPU PBS0	ST	CMOS	General purpose I/O. Register enabled pull-high
	STCK	PBS0 IFS0	ST	—	STM clock input
	AN1	PBS0	AN	—	A/D Converter analog input
PB2/PTCK0/AN2	PB2	PBPU PBS0	ST	CMOS	General purpose I/O. Register enabled pull-high
	PTCK0	PBS0 IFS0	ST	—	PTM0 clock input
	AN2	PBS0	AN	—	A/D Converter analog input
PB3/PTCK1/AN3	PB3	PBPU PBS0	ST	CMOS	General purpose I/O. Register enabled pull-high
	PTCK1	PBS0 IFS0	ST	—	PTM1 clock input
	AN3	PBS0	AN	—	A/D Converter analog input
PB4/INT0/PTP0B/AN4	PB4	PBPU PBS1	ST	CMOS	General purpose I/O. Register enabled pull-high
	INT0	PBS1 INTEG INTC0 IFS2	ST	—	External Interrupt 0 input
	PTP0B	PBS1	—	CMOS	PTM0 inverted output
	AN4	PBS1	AN	—	A/D Converter analog input
PB5/INT1/STPB/AN5	PB5	PBPU PBS1	ST	CMOS	General purpose I/O. Register enabled pull-high
	INT1	PBS1 INTEG INTC0 IFS2	ST	—	External Interrupt 1 input
	STPB	PBS1	—	CMOS	STM inverted output
	AN5	PBS1	AN	—	A/D Converter analog input
PB6/STPI/AN6	PB6	PBPU PBS1	ST	CMOS	General purpose I/O. Register enabled pull-high
	STPI	PBS1 IFS1	ST	—	STM capture input
	AN6	PBS1	AN	—	A/D Converter analog input
PB7/RES/AN7	PB7	PBPU PBS1	ST	CMOS	General purpose I/O. Register enabled pull-high
	RES	PBS1	ST	—	Reset pin
	AN7	PBS1	AN	—	A/D Converter analog input
PC0/STPI/SCS	PC0	PCPU PCS0	ST	CMOS	General purpose I/O. Register enabled pull-high
	STPI	PCS0 IFS1	ST	—	STM capture input
	SCS	PCS0	ST	CMOS	SPI slave select

Pin Name	Function	OPT	I/T	O/T	Description
PC1/SDI/SDA/URX/UTX/ SEG0	PC1	PCPU PCS0	ST	CMOS	General purpose I/O. Register enabled pull-high
	SDI	PCS0	ST	—	SPI serial data input
	SDA	PCS0	ST	NMOS	I ² C data line
	URX/UTX	PCS0	ST	CMOS	UART serial data input in full-duplex communication or UART serial data input / output in Single Wire Mode communication
	SEG0	PCS0	—	AN	LCD segment output
PC2/SDO/UTX/SEG1	PC2	PCPU PCS0	ST	CMOS	General purpose I/O. Register enabled pull-high
	SDO	PCS0	—	CMOS	SPI serial data output
	UTX	PCS0	—	CMOS	UART serial data output
	SEG1	PCS0	—	AN	LCD segment output
PC3/SCK/SCL/SEG2	PC3	PCPU PCS0	ST	CMOS	General purpose I/O. Register enabled pull-high
	SCK	PCS0	ST	CMOS	SPI serial clock
	SCL	PCS0	ST	NMOS	I ² C clock line
	SEG2	PCS0	—	AN	LCD segment output
PC4/XT2	PC4	PCPU PCS1	ST	CMOS	General purpose I/O. Register enabled pull-high
	XT2	PCS1	—	AN	LXT oscillator pin
PC5/XT1	PC5	PCPU PCS1	ST	CMOS	General purpose I/O. Register enabled pull-high
	XT1	PCS1	AN	—	LXT oscillator pin
PC6	PC6	PCPU	ST	CMOS	General purpose I/O. Register enabled pull-high
PC7	PC7	PCPU	ST	CMOS	General purpose I/O. Register enabled pull-high
PD0/PTCK1	PD0	PDPU	ST	CMOS	General purpose I/O. Register enabled pull-high
	PTCK1	IFS0	ST	—	PTM1 clock input
PD1	PD1	PDPU	ST	CMOS	General purpose I/O. Register enabled pull-high
PD2/PTP1	PD2	PDPU PDS0	ST	CMOS	General purpose I/O. Register enabled pull-high
	PTP1	PDS0	—	CMOS	PTM1 output
PD3/PTP1B	PD3	PDPU PDS0	ST	CMOS	General purpose I/O. Register enabled pull-high
	PTP1B	PDS0	—	CMOS	PTM1 inverted output
PD4	PD4	PDPU	ST	CMOS	General purpose I/O. Register enabled pull-high
PD5	PD5	PDPU	ST	CMOS	General purpose I/O. Register enabled pull-high
SEG10~SEG31	SEgn	—	—	AN	LCD segment output
COM0~COM3	COMn	—	—	AN	LCD common output
VMAX	VMAX	—	PWR	—	IC maximum voltage, connect to VDD or V1
PLCD	PLCD	—	PWR	AN	LCD power supply
V1	V1	—	PWR	AN	LCD power supply
V2	V2	—	PWR	AN	LCD power supply
C1	C1	—	—	AN	LCD voltage pump
C2	C2	—	—	AN	LCD voltage pump
VDD	VDD	—	PWR	—	Digital positive power supply
VSS	VSS	—	PWR	—	Digital negative power supply

Legend: I/T: Input type;

OPT: Optional by register option;

ST: Schmitt Trigger input;

NMOS: NMOS output;

O/T: Output type;

PWR: Power;

CMOS: CMOS output;

AN: Analog signal

Absolute Maximum Ratings

Supply Voltage	$V_{SS}-0.3V$ to $6.0V$
Input Voltage	$V_{SS}-0.3V$ to $V_{DD}+0.3V$
Storage Temperature.....	$-60^{\circ}C$ to $150^{\circ}C$
Operating Temperature.....	$-40^{\circ}C$ to $85^{\circ}C$
I_{OH} Total	$-80mA$
I_{OL} Total	$80mA$
Total Power Dissipation	$500mW$

Note: These are stress ratings only. Stresses exceeding the range specified under “Absolute Maximum Ratings” may cause substantial damage to these devices. Functional operation of these devices at other conditions beyond those listed in the specification is not implied and prolonged exposure to extreme conditions may affect device reliability.

D.C. Characteristics

For data in the following tables, note that factors such as oscillator type, operating voltage, operating frequency, pin load conditions, temperature and program instruction type, etc., can all exert an influence on the measured values.

Operating Voltage Characteristics

$T_a=-40^{\circ}C-85^{\circ}C$

Symbol	Parameter	Test Conditions	Min.	Typ.	Max.	Unit
V_{DD}	Operating Voltage – HXT	$f_{SYS}=1MHz$	2.2	—	5.5	V
		$f_{SYS}=2MHz$	2.2	—	5.5	
		$f_{SYS}=4MHz$	2.2	—	5.5	
		$f_{SYS}=8MHz$	2.2	—	5.5	
		$f_{SYS}=12MHz$	2.7	—	5.5	
		$f_{SYS}=16MHz$	3.3	—	5.5	
	Operating Voltage – HIRC	$f_{SYS}=2MHz$	1.8	—	5.5	V
		$f_{SYS}=4MHz$	1.8	—	5.5	
		$f_{SYS}=8MHz$	2.2	—	5.5	
	Operating Voltage – MIRC	$f_{SYS}=64kHz$	1.8	—	5.5	V
		$f_{SYS}=128kHz$	1.8	—	5.5	
		$f_{SYS}=256kHz$	1.8	—	5.5	
		$f_{SYS}=512kHz$	1.8	—	5.5	
	Operating Voltage – LXT	$f_{SYS}=32.768kHz$	1.8	—	5.5	V
	Operating Voltage – LIRC	$f_{SYS}=32.768kHz$	1.8	—	5.5	V

Standby Current Characteristics

Ta=25°C, unless otherwise specified

Symbol	Standby Mode	Test Conditions		Min.	Typ.	Max.	Max. @85°C	Unit
		V _{DD}	Conditions					
I _{STB}	SLEEP Mode	1.8V	WDT off	—	0.08	0.12	1.40	μA
		3V		—	0.08	0.12	1.40	μA
		5V		—	0.15	0.29	2.20	μA
		1.8V	WDT off, Time Base on, LIRC on	—	0.4	0.7	2.3	μA
		3V		—	0.5	1.0	2.5	μA
		5V		—	1.3	2.0	3.6	μA
		1.8V	WDT off, Time Base on, LXT on (LXTSP=0)	—	0.7	1.1	2.6	μA
		3V		—	0.75	1.20	2.70	μA
		5V		—	0.8	1.6	3.6	μA
		1.8V	WDT on, LIRC on	—	0.4	0.7	2.3	μA
		3V		—	0.5	1.0	2.5	μA
		5V		—	1.3	2.0	3.6	μA
		1.8V	WDT on, LXT on (LXTSP=0)	—	0.7	1.1	2.6	μA
		3V		—	0.8	1.2	2.7	μA
		5V		—	0.9	1.6	3.6	μA
	IDLE0 Mode – LIRC	1.8V	f _{SUB} on	—	0.8	1.1	3.2	μA
		3V		—	1.3	1.7	4.6	μA
		5V		—	2.9	3.8	9.2	μA
	IDLE0 Mode – LXT	1.8V	f _{SUB} on (LXTSP=0)	—	1.0	1.3	4.0	μA
		3V		—	1.5	2.0	4.8	μA
		5V		—	2.1	2.8	6.6	μA
	IDLE1 Mode – MIRC	1.8V	f _{SUB} on, f _{SYS} =64kHz	—	2.1	2.8	3.8	μA
		3V		—	3.2	4.2	8.4	μA
		5V		—	6.0	7.8	15.4	μA
		1.8V	f _{SUB} on, f _{SYS} =128kHz	—	3.0	3.9	7.4	μA
		3V		—	4.7	6.1	11.4	μA
		5V		—	8.9	11.6	21.2	μA
		1.8V	f _{SUB} on, f _{SYS} =256kHz	—	4.6	5.1	11.0	μA
		3V		—	7.6	8.4	18.0	μA
		5V		—	14.6	19.0	23.0	μA
		1.8V	f _{SUB} on, f _{SYS} =512kHz	—	7.9	10.3	18.0	μA
		3V		—	13.6	17.7	30.0	μA
		5V		—	26.4	34.3	56.0	μA
	IDLE1 Mode – HIRC	1.8V	f _{SUB} on, f _{SYS} =2MHz	—	50	65	70	μA
		3V		—	100	120	130	μA
		5V		—	210	250	270	μA
		1.8V	f _{SUB} on, f _{SYS} =4MHz	—	90	110	120	μA
		3V		—	180	220	230	μA
		5V		—	350	420	450	μA
		2.2V	f _{SUB} on, f _{SYS} =8MHz	—	210	250	270	μA
		3V		—	340	410	440	μA
		5V		—	660	790	860	μA

Symbol	Standby Mode	Test Conditions		Min.	Typ.	Max.	Max. @85°C	Unit
		V _{DD}	Conditions					
I _{STB}	IDLE1 Mode – HXT	2.2V	f _{SUB} on, f _{SYS} =1MHz	—	60	75	80	μA
		3V		—	110	130	140	μA
		5V		—	280	380	390	μA
		2.2V	f _{SUB} on, f _{SYS} =2MHz	—	60	75	80	μA
		3V		—	110	130	140	μA
		5V		—	280	380	390	μA
		2.2V	f _{SUB} on, f _{SYS} =4MHz	—	110	130	140	μA
		3V		—	175	210	220	μA
		5V		—	400	480	490	μA
		2.2V	f _{SUB} on, f _{SYS} =8MHz	—	175	210	220	μA
		3V		—	275	330	340	μA
		5V		—	600	720	730	μA
		2.7V	f _{SUB} on, f _{SYS} =12MHz	—	400	480	490	μA
		3V		—	480	580	590	μA
		5V		—	1080	1300	1310	μA
		3.6V	f _{SUB} on, f _{SYS} =16MHz	—	780	940	950	μA
5V	—	1350		1620	1630	μA		

Note: When using the characteristic table data, the following notes should be taken into consideration:

1. Any digital inputs are setup in a non floating condition.
2. All measurements are taken under conditions of no load and with all peripherals in an off state.
3. There are no DC current paths.
4. All Standby Current values are taken after a HALT instruction execution thus stopping all instruction execution.
5. The value of 85°C are guaranteed by design and not test in production.

Operating Current Characteristics

T_a=-40°C~85°C, unless otherwise specified

Symbol	Operating Mode	Test Conditions		Min.	Typ.	Max.	Max. @85°C	Unit
		V _{DD}	Conditions					
I _{DD}	SLOW Mode – LIRC	1.8V	f _{SYS} =32.768kHz	—	1.5	2.0	3.0	μA
		3V		—	3.8	5.0	6.0	μA
		5V		—	11.8	15.3	18.0	μA
		1.8V	f _{SYS} =32.768kHz, LVR enable	—	4.7	6.1	7.1	μA
		3V		—	8.0	10.4	12.0	μA
		5V		—	18	24	27	μA
	SLOW Mode – LXT	1.8V	f _{SYS} =32.768kHz (LXTSP=0)	—	1.6	2.1	3.0	μA
		3V		—	3.8	5.0	6.0	μA
		5V		—	11.8	15.3	18.0	μA
		1.8V	f _{SYS} =32.768kHz (LXTSP=0), LVR enable	—	4.8	6.2	7.2	μA
		3V		—	8.0	10.4	12.0	μA
		5V		—	18	24	27	μA

Symbol	Operating Mode	Test Conditions		Min.	Typ.	Max.	Max. @85°C	Unit
		V _{DD}	Conditions					
I _{DD}	FAST Mode – MIRC	1.8V	f _{sys} =64kHz	—	3.3	4.4	5.0	μA
		3V		—	6.8	9.0	11.0	μA
		5V		—	17	22	26	μA
		1.8V	f _{sys} =128kHz	—	5.2	7.0	8.0	μA
		3V		—	11	15	17	μA
		5V		—	25	33	38	μA
		1.8V	f _{sys} =256kHz	—	9.4	13.0	14.0	μA
		3V		—	19	25	29	μA
		5V		—	42	55	63	μA
		1.8V	f _{sys} =512kHz	—	17	22	26	μA
		3V		—	36	47	54	μA
		5V		—	74	96	111	μA
	FAST Mode – HIRC	1.8V	f _{sys} =2MHz	—	0.10	0.12	0.12	mA
		3V		—	0.18	0.22	0.22	mA
		5V		—	0.42	0.55	0.55	mA
		1.8V	f _{sys} =4MHz	—	0.16	0.19	0.19	mA
		3V		—	0.37	0.45	0.45	mA
		5V		—	0.75	0.90	0.90	mA
		2.2V	f _{sys} =8MHz	—	0.5	0.6	0.6	mA
		3V		—	0.70	0.84	0.84	mA
	5V	—		1.5	1.8	1.8	mA	
	FAST Mode – HXT	2.2V	f _{sys} =1MHz	—	0.08	0.12	0.12	mA
		3V		—	0.15	0.20	0.20	mA
		5V		—	0.37	0.50	0.50	mA
		2.2V	f _{sys} =2MHz	—	0.15	0.18	0.18	mA
		3V		—	0.20	0.24	0.24	mA
		5V		—	0.46	0.55	0.55	mA
		2.2V	f _{sys} =4MHz	—	0.20	0.24	0.24	mA
		3V		—	0.35	0.42	0.42	mA
		5V		—	0.75	0.90	0.90	mA
		2.2V	f _{sys} =8MHz	—	0.36	0.43	0.43	mA
		3V		—	0.60	0.72	0.72	mA
		5V		—	1.30	1.56	1.56	mA
2.7V		f _{sys} =12MHz	—	0.80	0.96	0.96	mA	
3V			—	1.0	1.2	1.2	mA	
5V			—	2.30	2.76	2.76	mA	
3.6V	f _{sys} =16MHz	—	1.60	1.92	1.92	mA		
5V		—	2.90	3.48	3.48	mA		

Note: When using the characteristic table data, the following notes should be taken into consideration:

1. Any digital inputs are setup in a non floating condition.
2. All measurements are taken under conditions of no load and with all peripherals in an off state.
3. There are no DC current paths.
4. All Operating Current values are measured using a continuous NOP instruction program loop.
5. The value of 85°C are guaranteed by design and not test in production.

A.C. Characteristics

For data in the following tables, note that factors such as oscillator type, operating voltage, operating frequency and temperature etc., can all exert an influence on the measured values.

High Speed Internal Oscillator – HIRC – Frequency Accuracy

During the program writing operation the writer will trim the HIRC oscillator at a user selected HIRC frequency and user selected voltage of either 3V or 5V.

Symbol	Parameter	Test Conditions		Min.	Typ.	Max.	Unit
		V _{DD}	Temp.				
f _{HIRC}	2MHz Writer Trimmed HIRC Frequency	3V/5V	25°C	-1%	2	+1%	MHz
			-20°C~60°C	-2%	2	+2%	
			-40°C~85°C	-3%	2	+3%	
		2.2V~5.5V	25°C	-6%	2	+9%	
			-40°C~85°C	-6%	2	+10%	
			1.8V~5.5V	25°C	-6%	2	
	4MHz Writer Trimmed HIRC Frequency	3V/5V	25°C	-1%	4	+1%	MHz
			-40°C~85°C	-2.5%	4	+2.5%	
			2.2V~5.5V	25°C	-2.5%	4	
		1.8V~5.5V	-40°C~85°C	-3%	4	+3%	
			25°C	-3.5%	4	+3.5%	
			-40°C~85°C	-4%	4	+4%	
8MHz Writer Trimmed HIRC Frequency	3V/5V	25°C	-1%	8	+1%	MHz	
		-40°C~85°C	-10%	8	+2%		
		2.2V~5.5V	25°C	-10%	8		+3%
	1.8V~5.5V	-40°C~85°C	-15%	8	+5%		

- Note: 1. The 3V/5V values for V_{DD} are provided as these are the two selectable fixed voltages at which the HIRC frequency is trimmed by the writer.
2. The row below the 3V/5V trim voltage row is provided to show the values for the full V_{DD} range operating voltage. It is recommended that the trim voltage is fixed at 3V for application voltage ranges from 1.8V to 3.6V and fixed at 5V for application voltage ranges from 3.3V to 5.5V.
3. The minimum and maximum tolerance values provided in the table are only for the frequency at which the writer trims the HIRC oscillator. After trimming at this chosen specific frequency any change in HIRC oscillator frequency using the oscillator register control bits by the application program will give a frequency tolerance to within ±20%.

Middle Speed Internal Oscillator Characteristics – MIRC

Symbol	Parameter	Test Conditions		Min.	Typ.	Max.	Unit
		V _{DD}	Temp.				
f _{MIRC}	64kHz Writer Trimmed MIRC Frequency ⁽¹⁾	3V	25°C	-1%	64	+1%	kHz
			-40°C~85°C	-10%	64	+10%	
		1.8V~5.5V	-40°C~85°C	-20%	64	+20%	
			f _{MIRC} =128/256/512kHz ⁽²⁾ Ta=25°C	-15%	f _{MIRC}	+15%	
	1.8V~5.5V	f _{MIRC} =128/256/512kHz ⁽²⁾ Ta=-40°C~85°C	-30%	f _{MIRC}	+30%		
		3V	25°C	-1%	128	+1%	kHz
	-40°C~85°C		-10%	128	+10%		
	1.8V~5.5V	-40°C~85°C	-20%	128	+20%		
		f _{MIRC} =64/256/512kHz ⁽²⁾ Ta=25°C	-15%	f _{MIRC}	+15%		
	1.8V~5.5V	f _{MIRC} =64/256/512kHz ⁽²⁾ Ta=-40°C~85°C	-30%	f _{MIRC}	+30%		
		3V	25°C	-1%	256	+1%	kHz
	-40°C~85°C		-10%	256	+10%		
1.8V~5.5V	-40°C~85°C	-20%	256	+20%			
	f _{MIRC} =64/128/512kHz ⁽²⁾ Ta=25°C	-15%	f _{MIRC}	+15%			
1.8V~5.5V	f _{MIRC} =64/128/512kHz ⁽²⁾ Ta=-40°C~85°C	-30%	f _{MIRC}	+30%			
	3V	25°C	-1%	512	+1%	kHz	
-40°C~85°C		-10%	512	+10%			
1.8V~5.5V	-40°C~85°C	-20%	512	+20%			
	f _{MIRC} =64/128/256kHz ⁽²⁾ Ta=25°C	-15%	f _{MIRC}	+15%			
1.8V~5.5V	f _{MIRC} =64/128/256kHz ⁽²⁾ Ta=-40°C~85°C	-30%	f _{MIRC}	+30%			
	t _{START}	MIRC Start Up Time	—	—	—	100	μs

Note: 1. The MIRC frequency is trimmed by the writer when the V_{DD} is 3V and the temperature is 25°C.

2. The MIRC frequency is not writer trimmed.

Low Speed Internal Oscillator Characteristics – LIRC

Symbol	Parameter	Test Conditions		Min.	Typ.	Max.	Unit
		V _{DD}	Temp.				
f _{LIRC}	Writer Trimmed LIRC Frequency	3V	25°C	-0.2%	32.768	+0.2%	kHz
			-10°C~50°C	-3%	32.768	+3%	
			-40°C~85°C	-5%	32.768	+5%	
		1.8V~5.5V	25°C	-3%	32.768	+3%	
-40°C~85°C	-7%		32.768	+7%			
t _{START}	LIRC Start Up Time	—	—	—	—	100	μs

Note: The LIRC frequency is trimmed by the writer when the V_{DD} is 3V and the temperature is 25°C.

Low Speed External Crystal Oscillator Characteristics – LXT

Ta=-40°C~85°C

Symbol	Parameter	Test Conditions		Min.	Typ.	Max.	Unit
		V _{DD}	Conditions				
f _{LXT}	Oscillator Frequency	1.8V~5.5V	—	—	32768	—	Hz
t _{START}	LXT Start Up Time	3V	—	—	—	1000	ms
		5V	—	—	—	1000	ms
Duty Cycle	Duty Cycle	—	—	40	—	60	%
R _{NEG}	Negative Resistance	1.8V	—	3×ESR	—	—	Ω

Note: C1, C2 and R_P are external components. C1=C2=10pF, R_P=10MΩ, C_L=12.5pF, ESR=30kΩ.

Operating Frequency Characteristic Curves

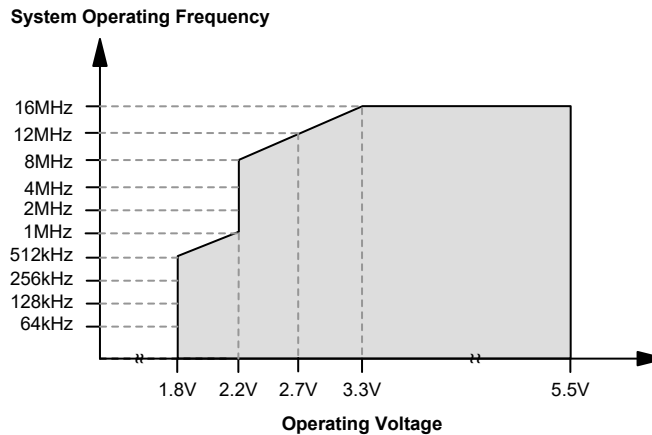

Note: The range of the operating voltage is from 1.8V to 5.5V for the 2/4MHz HIRC oscillator and it is from 2.2V to 5.5V for the 2/4MHz HXT oscillator.

System Start Up Time Characteristics

Ta=-40°C~85°C

Symbol	Parameter	Test Conditions		Min.	Typ.	Max.	Unit
		V _{DD}	Conditions				
t _{SST}	System Start-up Time (Wake-up from Condition where f _{sys} is off)	—	f _{sys} =f _H ~f _H /64, f _H =f _{HXT}	115	128	141	t _{sys}
		—	f _{sys} =f _H ~f _H /64, f _H =f _{HIRC} OR f _{MIRC}	14	16	18	t _{sys}
		—	f _{sys} =f _{SUB} =f _{LXT}	—	1024	—	t _{LXT}
		—	f _{sys} =f _{SUB} =f _{LIRC}	—	2	—	t _{LIRC}
	System Start-up Time (Wake-up from Condition where f _{sys} is on)	—	f _{sys} =f _H ~f _H /64, f _H =f _{HIRC} OR f _{MIRC} OR f _{HXT}	—	2	—	t _{sys}
		—	f _{sys} =f _{SUB} =f _{LIRC} OR f _{LXT}	—	2	—	t _{SUB}
		—	f _{HXT} switches from off → on	—	1024	—	t _{HXT}
	System Speed Switch Time (FAST to SLOW Mode or SLOW to FAST Mode)	—	f _{HIRC} OR f _{MIRC} switches from off → on	—	16	—	t _{HIRC} OR t _{MIRC}
		—	f _{LXT} switches from off → on	—	1024	—	t _{LXT}

Symbol	Parameter	Test Conditions		Min.	Typ.	Max.	Unit
		V _{DD}	Conditions				
t _{RSTD}	System Reset Delay Time (Reset source from Power-on reset or LVR hardware reset)	—	RR _{POR} =5V/ms	14	18	22	ms
	System Reset Delay Time (LVRC/WDT/ RSTC software reset)	—	—				
	System Reset Delay Time (Reset source from WDT overflow or RES pin reset)	—	—	14	18	22	ms
t _{SRESET}	Minimum Software Reset Width to Reset	—	—	45	90	120	μs

- Note: 1. For the System Start-up time values, whether f_{sys} is on or off depends upon the mode type and the chosen f_{sys} system oscillator. Details are provided in the System Operating Modes section.
2. The time units, shown by the symbols t_{HIRC}, t_{MIRC}, t_{HXT} etc. are the inverse of the corresponding frequency values as provided in the frequency tables. For example, t_{HIRC}=1/f_{HIRC}, t_{sys}=1/f_{sys} etc.
3. If the LIRC is used as the system clock and if it is off when in the SLEEP Mode, then an additional LIRC start up time, t_{START}, as provided in the LIRC frequency table, must be added to the t_{SS} time in the table above.
4. The System Speed Switch Time is effectively the time taken for the newly activated oscillator to start up.

Input/Output Characteristics

T_a=-40°C~85°C

Input/Output (without Multi-power) D.C. Characteristics

Symbol	Parameter	Test Conditions		Min.	Typ.	Max.	Unit
		V _{DD}	Conditions				
V _{IL}	Input Low Voltage for I/O Ports Except PC0~PC3 Pins	5V	—	0	—	1.5	V
		—	—	0	—	0.2V _{DD}	V
	Input Low Voltage for $\overline{\text{RES}}$ Pin	—	V _{DD} ≥ 2.7V	0	—	0.4V _{DD}	V
		—	1.8V ≤ V _{DD} < 2.7V	0	—	0.3V _{DD}	V
V _{IH}	Input High Voltage for I/O Ports Except PC0~PC3 Pins	5V	—	3.5	—	5.0	V
		—	—	0.8V _{DD}	—	V _{DD}	V
	Input High Voltage for $\overline{\text{RES}}$ Pin	—	—	0.9V _{DD}	—	V _{DD}	V
I _{OL}	Sink Current for I/O Ports Except PC0~PC3 Pins	3V	V _{OL} =0.1V _{DD}	16	32	—	mA
		5V		32	65	—	mA
I _{OH}	Source Current for I/O Ports Except PC0~PC3 Pins	3V	V _{OH} =0.9V _{DD}	-4	-8	—	mA
		5V		-8	-16	—	mA
R _{PH}	Pull-high Resistance Except PC0~PC3 Pins ⁽¹⁾	3V	LVPU=0, P _x PU=FFH (P _x : PA, PB, PC or PD)	20	60	100	kΩ
		5V		10	30	50	
		3V	LVPU=1, P _x PU=FFH (P _x : PA, PB, PC or PD)	6.67	15	23	
		5V		3.5	7.5	12	
I _{LEAK}	Input Leakage Current Except PC0~PC3 Pins	5V	V _{IN} =V _{DD} or V _{IN} =V _{SS}	—	—	±1	μA
t _{INT}	External Interrupt Input Minimum Pulse Width	—	—	10	—	—	μs
t _{RES}	External Reset Pin Minimum Pulse Width	—	—	10	—	—	μs
t _{TCK}	xTM Clock Input Minimum Pulse Width	—	—	0.3	—	—	μs
t _{TPI}	STM Capture Input Minimum Pulse Width	—	—	0.3	—	—	μs

Symbol	Parameter	Test Conditions		Min.	Typ.	Max.	Unit
		V _{DD}	Conditions				
f _{TMCLK}	STM Maximum Timer Clock Source Frequency	5V	—	—	—	1	f _{sys}
t _{CPW}	STM Minimum Capture Pulse Width	—	—	t _{CPW} ⁽²⁾	—	—	μs

Note: 1. The R_{PH} internal pull-high resistance value is calculated by connecting to ground and enabling the input pin with a pull-high resistor and then measuring the pin current at the specified supply voltage level. Dividing the voltage by this measured current provides the R_{PH} value.

2. For STM

$$t_{CPW} = \max(2 \times t_{TMCLK}, t_{TPI})$$

Ex1: If f_{TMCLK}=16MHz, t_{TPI}=0.3μs, then t_{CPW}=max(0.125μs, 0.3μs)=0.3μs

Ex2: If f_{TMCLK}=8MHz, t_{TPI}=0.3μs, then t_{CPW}=max(0.25μs, 0.3μs)=0.3μs

Ex3: If f_{TMCLK}=4MHz, t_{TPI}=0.3μs, then t_{CPW}=max(0.5μs, 0.3μs)=0.5μs

Where t_{TMCLK}=1/f_{TMCLK}

Input/Output (with Multi-power) D.C. Characteristics

Symbol	Parameter	Test Conditions		Min.	Typ.	Max.	Unit
		V _{DD}	Conditions				
V _{DD}	V _{DD} Power Supply for PC0~PC3 Pins	—	—	1.8	5.0	5.5	V
V _{DDIO}	V _{DDIO} Power Supply for PC0~PC3 Pins	—	—	1.8	—	V _{DD}	V
V _{IL}	Input Low Voltage for PC0~PC3 Pins	5V	Pin power=V _{DD} or V _{DDIO} V _{DDIO} =V _{DD}	0	—	1.5	V
		—	Pin power=V _{DD} or V _{DDIO}	0	—	0.2 (V _{DD} /V _{DDIO})	V
V _{IH}	Input High Voltage for PC0~PC3 Pins	5V	Pin power=V _{DD} or V _{DDIO} V _{DDIO} =V _{DD}	3.5	—	5.0	V
		—	Pin power=V _{DD} or V _{DDIO}	0.8 (V _{DD} /V _{DDIO})	—	V _{DD} /V _{DDIO}	V
I _{OL}	Sink Current for PC0~PC3 Pins	3V	V _{OL} =0.1(V _{DD} /V _{DDIO}) V _{DDIO} =V _{DD}	16	32	—	mA
		5V	V _{DDIO} =V _{DD}	32	65	—	mA
		5V	V _{OL} =0.1(V _{DD} /V _{DDIO}) V _{DDIO} =3V	20	40	—	mA
I _{OH}	Source Current for PC0~PC3 Pins	3V	V _{OH} =0.9(V _{DD} /V _{DDIO}), V _{DDIO} =V _{DD}	-4	-8	—	mA
		5V	V _{DDIO} =V _{DD}	-8	-16	—	mA
		5V	V _{OH} =0.9(V _{DD} /V _{DDIO}), V _{DDIO} =3V	-2.5	-5.0	—	mA
R _{PH}	Pull-high Resistance for PC0~PC3 Pins ^(Note)	3V	V _{DDIO} =V _{DD}	20	60	100	kΩ
		5V	LVPU=0	10	30	50	
		5V	V _{DDIO} =3V LVPU=0	36	110	180	
I _{LEAK}	Input Leakage Current for PC0~PC3 Pins	5V	V _{IN} =V _{DD} or V _{IN} =V _{SS}	—	—	±1	μA

Note: The R_{PH} internal pull-high resistance value is calculated by connecting to ground and enabling the input pin with a pull-high resistor and then measuring the pin current at the specified supply voltage level. Dividing the voltage by this measured current provides the R_{PH} value.

Memory Characteristics

Ta=-40°C~85°C, unless otherwise specified

Symbol	Parameter	Test Conditions		Min.	Typ.	Max.	Unit
		V _{DD}	Conditions				
Flash Program Memory							
V _{DD}	V _{DD} for Read	—	—	1.8	—	5.5	V
	V _{DD} for Erase/Write	—	—	2.2	—	5.5	V
t _{DEW}	Erase / Write Cycle Time	—	—	—	2	3	ms
I _{DDPGM}	Programming / Erase Current on V _{DD}	—	—	—	—	5	mA
E _P	Cell Endurance	—	—	10K	—	—	E/W
t _{RETD}	ROM Data Retention Time	—	Ta=25°C	—	40	—	Year
Data EEPROM Memory							
V _{DD}	V _{DD} for Read	—	—	1.8	—	5.5	V
	V _{DD} for Write	—	—	2.2	—	5.5	V
t _{EERD}	Read Cycle Time	—	—	—	—	4	t _{sys}
t _{EEWR}	Write Cycle Time	—	—	—	4	6	ms
E _P	Cell Endurance	—	—	100K	—	—	E/W
t _{RETD}	Data Retention Time	—	Ta=25°C	—	40	—	Year
RAM Data Memory							
V _{DR}	Data Retention Voltage	—	—	1.0	—	—	V

Note: “E/W” means Erase/Write times.

LCD Electrical Characteristics

Ta=-40°C~85°C

Symbol	Parameter	Test Conditions		Min.	Typ.	Max.	Unit
		V _{DD}	Conditions				
V _{IN}	LCD Operating Voltage	—	R type, power supply from PLCD pin, PLCD[3:0]=1xxxB	3.0	—	5.5	V
		—	C type, power supply from PLCD pin	2.0	—	3.7	
		—	C type, power supply from V1 pin	3.0	—	5.5	
		—	C type, power supply from V2 pin	1.0	—	1.8	
		—	C type, power supply from V _A	3.0	—	5.5	
		—	C type, power supply from V _B	2.0	—	3.7	
		—	C type, power supply from V _C , no load	-10%	1.04	+10%	
I _{LCD}	Additional Current for LCD Enable (R type)	3V	R _T =1170kΩ, no load,	—	3	6	μA
		5V	V _A =V _{PLCD} =V _{DD} , 1/3 bias	—	5	10	
		3V	R _T =225kΩ, no load,	—	16	28	
		5V	V _A =V _{PLCD} =V _{DD} , 1/3 bias	—	21	40	
		3V	R _T =60kΩ, no load,	—	50	75	
		5V	V _A =V _{PLCD} =V _{DD} , 1/3 bias	—	80	120	
	Additional Current for LCD Enable (C type)	3V	No load, V _A =V _I =V _{DD} , 1/3 bias, LCDP[1:0]=11B	—	0.3	0.6	
		5V	LCDPCK[2:0]=000B	—	0.5	1.0	
		3V	No load, V _A =V _I , 1/3 bias, LCDP[1:0]=01B (V _C =V _{REFIN})	—	1.6	3.0	
		5V	LCDPCK[2:0]=000B	—	1.8	5.0	
I _{LCDOL}	LCD Commom and Segment Sink Current	3V	V _{OL} =0.1V _{DD}	210	420	—	μA
		5V		350	700	—	μA

Symbol	Parameter	Test Conditions		Min.	Typ.	Max.	Unit
		V _{DD}	Conditions				
I _{LCDOH}	LCD Common and Segment Source Current	3V	V _{OH} =0.9V _{DD}	-80	-160	—	μA
		5V		-180	-360	—	μA

LVR/LVD Electrical Characteristics

T_a=-40°C~85°C

Symbol	Parameter	Test Conditions		Min.	Typ.	Max.	Unit
		V _{DD}	Conditions				
V _{LVR}	Low Voltage Reset Voltage	—	LVR enable, voltage select 1.7V	-5%	1.7	+5%	V
		—	LVR enable, voltage select 1.9V		1.9		
		—	LVR enable, voltage select 2.55V	-3%	2.55	+3%	
		—	LVR enable, voltage select 3.15V		3.15		
		—	LVR enable, voltage select 3.8V		3.8		
V _{LVD}	Low Voltage Detection Voltage	—	LVD enable, voltage select 1.8V	-5%	1.8	+5%	V
		—	LVD enable, voltage select 2.0V		2.0		
		—	LVD enable, voltage select 2.4V		2.4		
		—	LVD enable, voltage select 2.7V		2.7		
		—	LVD enable, voltage select 3.0V		3.0		
		—	LVD enable, voltage select 3.3V		3.3		
		—	LVD enable, voltage select 3.6V		3.6		
		—	LVD enable, voltage select 4.0V		4.0		
I _{LVRLVDBG}	Operating Current	3V	LVD enable, LVR enable, V _{LVR} =1.9V, V _{LVD} =2V VBGEN=0	—	5.5	8.0	μA
		5V		—	7.5	10.0	μA
		3V	LVD enable, LVR enable, V _{LVR} =1.9V, V _{LVD} =2V VBGEN=1	—	130	168	μA
		5V		—	202	240	μA
t _{LVDS}	LVDO Stable Time	—	For LVR enable, VBGEN=0, LVD off → on	—	—	18	μs
		—	For LVR disable, VBGEN=0, LVD off → on	—	—	150	μs
t _{LVR}	Minimum Low Voltage Width to Reset	—	TLVR[1:0]=00B	120	240	480	μs
		—	TLVR[1:0]=01B	0.5	1.0	2.0	ms
		—	TLVR[1:0]=10B	1	2	4	
		—	TLVR[1:0]=11B	2	4	8	
t _{LVD}	Minimum Low Voltage Width to Interrupt	—	—	60	120	240	μs
I _{LVR}	Additional Current for LVR Enable	3V	LVD disable, VBGEN=0	—	4.5	6.0	μA
		5V		—	6.5	8.0	μA
I _{LVD}	Additional Current for LVD Enable	3V	LVR disable, VBGEN=0	—	4.5	6.0	μA
		5V		—	6.5	8.0	μA

Reference Voltage Characteristics

Ta=-40°C~85°C

Symbol	Parameter	Test Conditions		Min.	Typ.	Max.	Unit
		V _{DD}	Conditions				
V _{BG}	Bandgap Reference Voltage	—	—	-5%	1.2	+5%	V
t _{BGS}	V _{BG} Turn on Stable Time	—	No load	—	5	15	μs
I _{BG}	Additional Current for Bandgap Reference Enable	3V	LVR disable, LVD disable	—	125	160	μA
		5V		—	195	230	μA

Note: The V_{BG} voltage is used as the A/D converter internal input signal.

A/D Converter Electrical Characteristics

12-bit Resolution Mode

Ta=-40°C~85°C

Symbol	Parameter	Test Conditions		Min.	Typ.	Max.	Unit
		V _{DD}	Conditions				
V _{ADI}	Input Voltage	—	—	0	—	V _{REF}	V
V _{REF}	Reference Voltage	—	—	1.8	—	V _{DD}	V
N _R	Resolution	—	—	—	—	12	Bit
DNL	Differential Nonlinearity	2.0V~5.5V	V _{REF} =V _{DD} , t _{ADCK} =0.5μs, SACMS[1:0]=00B	-3	—	3	LSB
		1.8V~5.5V	V _{REF} =V _{DD} , t _{ADCK} =1μs, SACMS[1:0]=00B	-3	—	3	LSB
		1.8V~5.5V	V _{REF} =V _{DD} , t _{ADCK} =10μs, SACMS[1:0]=11B	-3	—	3	LSB
INL	Integral Nonlinearity	2.0V~5.5V	V _{REF} =V _{DD} , t _{ADCK} =0.5μs, SACMS[1:0]=00B	-4	—	4	LSB
		1.8V~5.5V	V _{REF} =V _{DD} , t _{ADCK} =1μs, SACMS[1:0]=00B	-4	—	4	LSB
		1.8V~5.5V	V _{REF} =V _{DD} , t _{ADCK} =10μs, SACMS[1:0]=11B	-8	—	8	LSB
I _{ADC}	Additional Current for A/D Converter Enable	1.8V	No load (t _{ADCK} =0.5μs), SACMS[1:0]=00B	—	160	240	μA
		3V		—	200	300	μA
		5V		—	260	390	μA
		1.8V	No load (t _{ADCK} =1μs), SACMS[1:0]=01B	—	140	210	μA
		3V		—	160	240	μA
		5V		—	230	345	μA
		1.8V	No load (t _{ADCK} =2μs), SACMS[1:0]=10B	—	85	125	μA
		3V		—	100	150	μA
		5V		—	130	195	μA
		1.8V	No load (t _{ADCK} =4μs), SACMS[1:0]=11B	—	50	75	μA
		3V		—	70	105	μA
		5V		—	90	135	μA

Symbol	Parameter	Test Conditions		Min.	Typ.	Max.	Unit
		V _{DD}	Conditions				
t _{ADCK}	A/D Converter Clock Period	—	AN≠Temperature Sensor, SACMS[1:0]=00B	0.5	—	1.0	μs
		—	AN≠Temperature Sensor, SACMS[1:0]=01B	1	—	2	μs
		—	AN≠Temperature Sensor, SACMS[1:0]=10B	2	—	4	μs
		—	AN≠Temperature Sensor, SACMS[1:0]=11B	4	—	10	μs
		2.2V~5.5V	AN=Temperature Sensor, SACMS[1:0]=00B	1	—	2	μs
t _{ON2ST}	A/D Converter On-to-Start Time	—	—	4	—	—	μs
t _{ADS}	A/D Converter Sampling Time	—	AN≠Temperature Sensor	—	4	—	t _{ADCK}
		2.2V~5.5V	AN=Temperature Sensor	—	46	—	t _{ADCK}
t _{ADC}	A/D Conversion Time (Including A/D Sample and Hold Time)	—	AN≠Temperature Sensor	—	16	—	t _{ADCK}
		2.2V~5.5V	AN=Temperature Sensor	—	58	—	t _{ADCK}
GERR	A/D Conversion Gain Error	—	V _{REF} =V _{DD}	-4	—	4	LSB
OSRR	A/D Conversion Offset Error	—	V _{REF} =V _{DD}	-4	—	4	LSB

10-bit Resolution Mode

T_a=-40°C~85°C

Symbol	Parameter	Test Conditions		Min.	Typ.	Max.	Unit
		V _{DD}	Conditions				
V _{DD}	Operating Voltage	—	—	1.8	—	5.5	V
V _{ADI}	Input Voltage	—	—	0	—	V _{REF}	V
V _{REF}	Reference Voltage	—	—	1.8	—	V _{DD}	V
N _R	Resolution	—	—	—	—	10	Bit
DNL	Differential Nonlinearity	2.0V~5.5V	V _{REF} =V _{DD} , t _{ADCK} =0.5μs, SACMS[1:0]=00B	-1.5	—	1.5	LSB
		1.8V~5.5V	V _{REF} =V _{DD} , t _{ADCK} =1μs, SACMS[1:0]=00B	-1.5	—	1.5	LSB
INL	Integral Nonlinearity	2.0V~5.5V	V _{REF} =V _{DD} , t _{ADCK} =0.5μs, SACMS[1:0]=00B	-2	—	2	LSB
		1.8V~5.5V	V _{REF} =V _{DD} , t _{ADCK} =1μs, SACMS[1:0]=00B	-2	—	2	LSB
		1.8V~5.5V	V _{REF} =V _{DD} , t _{ADCK} =10μs, SACMS[1:0]=11B	-2	—	2	LSB
I _{ADC}	Additional Current for A/D Converter Enable	1.8V	No load (t _{ADCK} =0.5μs), SACMS[1:0]=00B	—	130	195	μA
		3V		—	160	240	μA
		5V		—	210	315	μA
		1.8V	No load (t _{ADCK} =1μs), SACMS[1:0]=01B	—	80	120	μA
		3V		—	100	150	μA
		5V		—	130	195	μA
		1.8V	No load (t _{ADCK} =2μs), SACMS[1:0]=10B	—	55	85	μA
		3V		—	65	100	μA
		5V		—	90	135	μA
		1.8V	No load (t _{ADCK} =4μs), SACMS[1:0]=11B	—	50	75	μA
		3V		—	60	90	μA
		5V		—	85	130	μA

Symbol	Parameter	Test Conditions		Min.	Typ.	Max.	Unit
		V _{DD}	Conditions				
t _{ADCK}	A/D Converter Clock Period	—	SACMS[1:0]=00B	0.5	—	1.0	μs
		—	SACMS[1:0]=01B	1	—	2	μs
		—	SACMS[1:0]=10B	2	—	4	μs
		—	SACMS[1:0]=11B	4	—	10	μs
t _{ON2ST}	A/D Converter On-to-Start Time	—	—	4	—	—	μs
t _{ADS}	A/D Converter Sampling Time	—	SACMS[1:0]=00B, 01B, 10B	—	3	—	t _{ADCK}
		—	SACMS[1:0]=11B	—	2	—	t _{ADCK}
t _{ADC}	A/D Conversion Time (Including A/D Sample and Hold Time)	—	SACMS[1:0]=00B, 01B, 10B	—	13	—	t _{ADCK}
		—	SACMS[1:0]=11B	—	12	—	t _{ADCK}
GERR	A/D Conversion Gain Error	—	V _{REF} =V _{DD}	-2	—	2	LSB
OSRR	A/D Conversion Offset Error	—	V _{REF} =V _{DD}	-2	—	2	LSB

Temperature Sensor Characteristics

T_a=-40°C~85°C, unless otherwise specified

Symbol	Parameter	Test Conditions		Min.	Typ.	Max.	Unit
		V _{DD}	Conditions				
V _{DD}	Operating Voltage	—	—	2.2	—	5.5	V
I _{TS}	Temperature Sensor Operating Current	3V	TSEN=ADCEN=1, t _{ADCK} =1μs, ADC included, SABMS=0, SACMS[1:0]=00B	—	1260	1950	μA
		5V		—	1490	2250	μA
t _{TSS}	Temperature Sensor Turn on Stable Time	3V	—	—	—	100	μs
		5V	—	—	—	100	μs
V _{TSVREF}	Temperature Sensor Reference Voltage	3V	—	-5%	2.01	+5%	V
		5V	—	-5%	2.01	+5%	V
T _{ACC}	Temperature Accuracy (Error)	2.7V~4.5V	V _{REF} =V _{TSVREF} T _a =0°C~70°C	-2.0	—	+2.0	°C
		2.7V~5.5V		-3.0	—	+3.0	
		—	V _{REF} =V _{TSVREF} T _a =-40°C~85°C	—	±4.0	—	
		2.7V~4.5V		-4.0	—	+4.0	
TS _{Noise}	Temperature Noise	3V	No average	—	0.4	—	°C(p-p)
		5V		—	0.6	—	°C(p-p)

- Note: 1. The temperature accuracy T_{ACC} is defined as the error between the actual temperature and the temperature obtained by the conversion of the ADC code through the formula.
2. The temperature sensor is only used for the 12-bit resolution mode, with the A/D converter clock rate of up to 2MHz being selected (SABMS=0, SACMS[1:0]=00).

I²C Electrical Characteristics

Ta=25°C

Symbol	Parameter	Test Conditions		Min.	Typ.	Max.	Unit
		V _{DD}	Conditions				
f _{I2C}	I ² C Standard Mode (100kHz) f _{sys} Frequency <small>(Note)</small>	—	No clock debounce	2	—	—	MHz
			2 system clock debounce	4	—	—	
			4 system clock debounce	4	—	—	
	I ² C Fast Mode (400kHz) f _{sys} Frequency <small>(Note)</small>	—	No clock debounce	4	—	—	MHz
			2 system clock debounce	8	—	—	
			4 system clock debounce	8	—	—	
f _{SCL}	SCL Clock Frequency	3V/5V	Standard mode	—	—	100	kHz
			Fast mode	—	—	400	
t _{SCL(H)}	SCL Clock High Time	3V/5V	Standard mode	3.5	—	—	μs
			Fast mode	0.9	—	—	
t _{SCL(L)}	SCL Clock Low Time	3V/5V	Standard mode	3.5	—	—	μs
			Fast mode	0.9	—	—	
t _{FALL}	SCL and SDA Fall Time	3V/5V	Standard mode	—	—	1.3	μs
			Fast mode	—	—	0.34	
t _{RISE}	SCL and SDA Rise Time	3V/5V	Standard mode	—	—	1.3	μs
			Fast mode	—	—	0.34	
t _{SU(SDA)}	SDA Data Setup Time	3V/5V	Standard mode	0.25	—	—	μs
			Fast mode	0.1	—	—	
t _{H(SDA)}	SDA Data Hold Time	3V/5V	—	0.1	—	—	μs
t _{VD(SDA)}	SDA Data Valid Time	3V/5V	—	—	—	0.6	μs
t _{SU(STA)}	Start Condition Setup Time	3V/5V	Standard mode	3.5	—	—	μs
			Fast mode	0.6	—	—	
t _{H(STA)}	Start Condition Hold Time	3V/5V	—	0.6	—	—	μs
t _{SU(STO)}	Stop Condition Setup Time	3V/5V	Standard mode	3.5	—	—	μs
			Fast mode	0.6	—	—	

Note: Using the debounce function can make the transmission more stable and reduce the probability of communication failure due to interference.

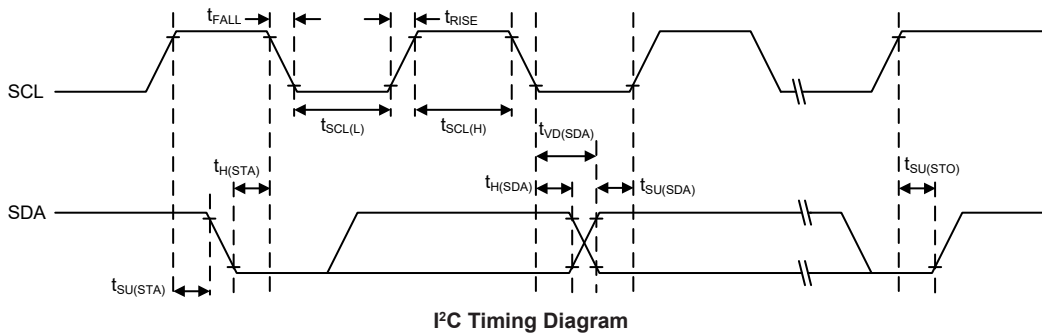

Power-on Reset Characteristics

Ta=-40°C~85°C

Symbol	Parameter	Test Conditions		Min.	Typ.	Max.	Unit
		V _{DD}	Conditions				
V _{POR}	V _{DD} Start Voltage to Ensure Power-on Reset	—	—	—	—	100	mV
RR _{POR}	V _{DD} Rising Rate to Ensure Power-on Reset	—	—	0.035	—	—	V/ms
t _{POR}	Minimum Time for V _{DD} Stays at V _{POR} to Ensure Power-on Reset	—	—	1	—	—	ms

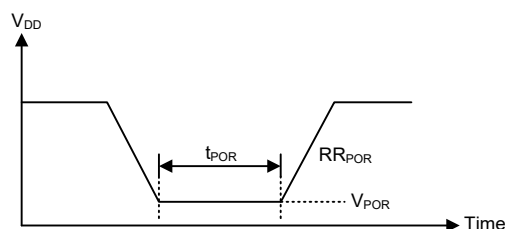

System Architecture

A key factor in the high-performance features of the Holtek range of microcontrollers is attributed to their internal system architecture. The range of devices take advantage of the usual features found within RISC microcontrollers providing increased speed of operation and enhanced performance. The pipelining scheme is implemented in such a way that instruction fetching and instruction execution are overlapped, hence instructions are effectively executed in one or two cycles for most of the standard or extended instructions respectively, with the exception of branch or call instructions which need one more cycle. An 8-bit wide ALU is used in practically all instruction set operations, which carries out arithmetic operations, logic operations, rotation, increment, decrement, branch decisions, etc. The internal data path is simplified by moving data through the Accumulator and the ALU. Certain internal registers are implemented in the Data Memory and can be directly or indirectly addressed. The simple addressing methods of these registers along with additional architectural features ensure that a minimum of external components is required to provide a functional I/O and A/D control system with maximum reliability and flexibility. This makes these devices suitable for low-cost, high-volume production for controller applications.

Clocking and Pipelining

The main system clock, derived from either an HIRC, MIRC, HXT, LIRC or LXT oscillator is subdivided into four internally generated non-overlapping clocks, T1~T4. The Program Counter is incremented at the beginning of the T1 clock during which time a new instruction is fetched. The remaining T2~T4 clocks carry out the decoding and execution functions. In this way, one T1~T4 clock cycle forms one instruction cycle. Although the fetching and execution of instructions takes place in consecutive instruction cycles, the pipelining structure of the microcontroller ensures that instructions are effectively executed in one instruction cycle. The exception to this are instructions where the contents of the Program Counter are changed, such as subroutine calls or jumps, in which case the instruction will take one more instruction cycle to execute.

For instructions involving branches, such as jump or call instructions, two machine cycles are required to complete instruction execution. An extra cycle is required as the program takes one cycle to first obtain the actual jump or call address and then another cycle to actually execute the branch. The requirement for this extra cycle should be taken into account by programmers in timing sensitive applications.

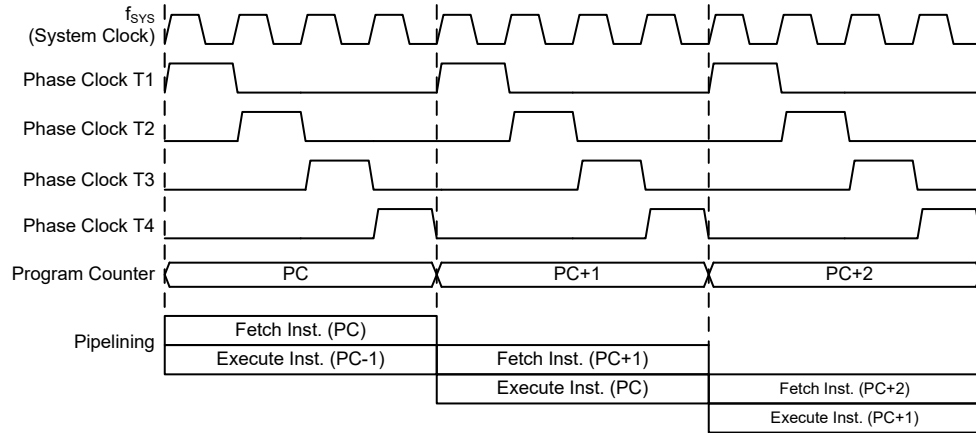

System Clocking and Pipelining

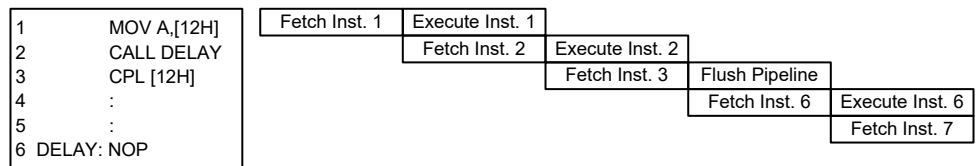

Instruction Fetching

Program Counter

During program execution, the Program Counter is used to keep track of the address of the next instruction to be executed. It is automatically incremented by one each time an instruction is executed except for instructions, such as “JMP” or “CALL” that demand a jump to a non-consecutive Program Memory address. Only the lower 8 bits, known as the Program Counter Low Register, are directly addressable by the application program.

When executing instructions requiring jumps to non-consecutive addresses such as a jump instruction, a subroutine call, interrupt or reset, etc., the microcontroller manages program control by loading the required address into the Program Counter. For conditional skip instructions, once the condition has been met, the next instruction, which has already been fetched during the present instruction execution, is discarded and a dummy cycle takes its place while the correct instruction is obtained.

Device	Program Counter	
	Program Counter High Byte	PCL Register
HT67L2540A	PC11~PC8	PCL7~PCL0
HT67L2550A	PC12~PC8	PCL7~PCL0

Program Counter

The lower byte of the Program Counter, known as the Program Counter Low register or PCL, is available for program control and is a readable and writeable register. By transferring data directly into this register, a short program jump can be executed directly; however, as only this low byte is available for manipulation, the jumps are limited to the present page of memory that is 256 locations. When such program jumps are executed it should also be noted that a dummy cycle will be inserted. Manipulating the PCL register may cause program branching, so an extra cycle is needed to pre-fetch.

Program Counter Read Register

The Program Counter read register is a read only register for reading the program counter value which indicates the current program execution address. Read the low byte register first then the high byte register. Reading the low byte register, PCRL, will read the low byte data of the current program execution address, and place the high byte data of the program counter into the 8-bit PCRH buffer. Then reading the PCRH register will read the corresponding data from the 8-bit PCRH buffer.

The following example shows how to read the current program execution address. When the current program execution address is 123H, the steps to execute the instructions are as follows:

- (1) MOV A, PCRL → the ACC value is 23H, and the PCRH value is 01H;
 MOV A, PCRH → the ACC value is 01H.
- (2) LMOV A, PCRL → the ACC value is 23H, and the PCRH value is 01H;
 LMOV A, PCRH → the ACC value is 01H.

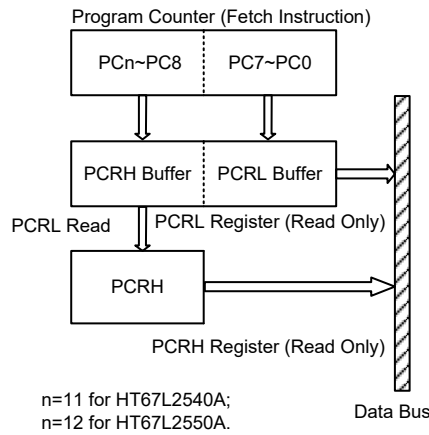

• PCRL Register

Bit	7	6	5	4	3	2	1	0
Name	D7	D6	D5	D4	D3	D2	D1	D0
R/W	R	R	R	R	R	R	R	R
POR	0	0	0	0	0	0	0	0

Bit 7~0 **D7~D0**: Low byte register bit 7 ~ bit 0

• PCRH Register – HT67L2540A

Bit	7	6	5	4	3	2	1	0
Name	—	—	—	—	D11	D10	D9	D8
R/W	—	—	—	—	R	R	R	R
POR	—	—	—	—	0	0	0	0

Bit 7~4 Unimplemented, read as “0”

Bit 3~0 **D11~D8**: High byte register bit 3 ~ bit 0

• **PCRH Register – HT67L2550A**

Bit	7	6	5	4	3	2	1	0
Name	—	—	—	D12	D11	D10	D9	D8
R/W	—	—	—	R	R	R	R	R
POR	—	—	—	0	0	0	0	0

Bit 7~5 Unimplemented, read as “0”

Bit 4~0 **D12~D8**: High byte register bit 4 ~ bit 0

Stack

This is a special part of the memory which is used to save the contents of the Program Counter only. The stack is organized into 8 levels and neither part of the data nor part of the program space, and is neither readable nor writeable. The activated level is indexed by the Stack Pointer, STKPTR[2:0]. At a subroutine call or interrupt acknowledge signal, the contents of the Program Counter are pushed onto the stack. At the end of a subroutine or an interrupt routine, signaled by a return instruction, RET or RETI, the Program Counter is restored to its previous value from the stack. After a device reset, the Stack Pointer will point to the top of the stack.

If the stack is full and an enabled interrupt takes place, the interrupt request flag will be recorded but the acknowledge signal will be inhibited. When the Stack Pointer is decremented, by RET or RETI, the interrupt will be serviced. This feature prevents stack overflow allowing the programmer to use the structure more easily. However, when the stack is full, a CALL subroutine instruction can still be executed which will result in a stack overflow. Precautions should be taken to avoid such cases which might cause unpredictable program branching.

If the stack is overflow, the first Program Counter save in the stack will be lost.

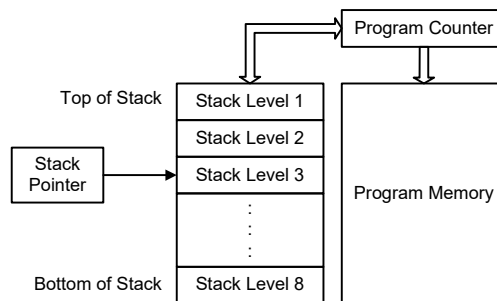

• **STKPTR Register**

Bit	7	6	5	4	3	2	1	0
Name	OSF	—	—	—	—	D2	D1	D0
R/W	R/W	—	—	—	—	R	R	R
POR	0	—	—	—	—	0	0	0

Bit 7 **OSF**: Stack overflow flag
 0: No stack overflow occurred
 1: Stack overflow occurred

The OSF bit will be set high, when the stack is full and a CALL subroutine instruction is executed, or when the stack is empty and a RET instruction is executed. The OSF bit can only be cleared to zero by the software.

Bit 6~3 Unimplemented, read as “0”

Bit 2~0 **D2~D0**: Stack pointer register bit 2 ~ bit 0

The following example shows how the Stack Pointer and Stack Overflow Flag change when program branching conditions occur.

- (1) When the CALL subroutine instruction is executed 9 times continuously and the RET instruction is not executed during the period, the corresponding changes of the STKPTR[2:0] and OSF bits are as follow:

CALL Execution Times	0	1	2	3	4	5	6	7	8	9
STKPTR[2:0] Bit Value	0	1	2	3	4	5	6	7	0	1
OSF Bit Value	0	0	0	0	0	0	0	0	0	1

- (2) When the OSF bit is set high and not cleared, it will remain high no matter how many times the RET instruction is executed.
- (3) When the stack is empty, the RET instruction is executed 8 times continuously, the corresponding changes of the STKPTR[2:0] and OSF bits are as follow:

RET Execution Times	0	1	2	3	4	5	6	7	8
STKPTR[2:0] Bit Value	0	7	6	5	4	3	2	1	0
OSF Bit Value	0	1	1	1	1	1	1	1	1

Arithmetic and Logic Unit – ALU

The arithmetic-logic unit or ALU is a critical area of the microcontroller that carries out arithmetic and logic operations of the instruction set. Connected to the main microcontroller data bus, the ALU receives related instruction codes and performs the required arithmetic or logical operations after which the result will be placed in the specified register. As these ALU calculation or operations may result in carry, borrow or other status changes, the status register will be correspondingly updated to reflect these changes. The ALU supports the following functions:

- Arithmetic operations:
 ADD, ADDM, ADC, ADCM, SUB, SUBM, SBC, SBCM, DAA,
 LADD, LADDM, LADC, LADCM, LSUB, LSUBM, LSBC, LSBCM, LDAA
- Logic operations:
 AND, OR, XOR, ANDM, ORM, XORM, CPL, CPLA,
 LAND, LANDM, LOR, LORM, LXOR, LXORM, LCPL, LCPLA
- Rotation:
 RRA, RR, RRCA, RRC, RLA, RL, RLCA, RLC,
 LRR, LRRCA, LRRCA, LRRCA, LRRCA, LRRCA, LRRCA, LRRCA
- Increment and Decrement:
 INCA, INC, DECA, DEC,
 LINCA, LINC, LDECA, LDEC
- Branch decision:
 JMP, SZ, SZA, SNZ, SIZ, SDZ, SIZA, SDZA, CALL, RET, RETI,
 LSNZ, LSZ, LSZA, LSIZ, LSIZA, LSDZ, LSDZA

Flash Program Memory

The Program Memory is the location where the user code or program is stored. For these devices the Program Memory is Flash type, which means it can be programmed and re-programmed a large number of times, allowing the user the convenience of code modification on the same device. By using the appropriate programming tools, the Flash devices offer users the flexibility to conveniently debug and develop their applications while also offering a means of field programming and updating.

Structure

The Program Memory has a capacity of 4K×16 bits to 8K×16 bits. The Program Memory is addressed by the Program Counter and also contains data, table information and interrupt entries. Table data, which can be set in any location within the Program Memory, is addressed by a separate table pointer register.

Device	Capacity
HT67L2540A	4K×16
HT67L2550A	8K×16

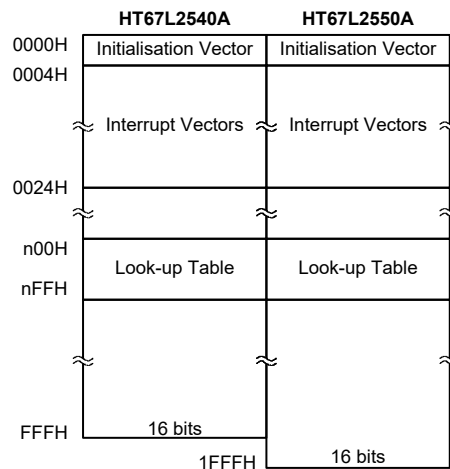

Program Memory Structure

Special Vectors

Within the Program Memory, certain locations are reserved for the reset and interrupts. The location 0000H is reserved for use by these devices reset for program initialisation. After a device reset is initiated, the program will jump to this location and begin execution.

Look-up Table

Any location within the Program Memory can be defined as a look-up table where programmers can store fixed data. To use the look-up table, the table pointer must first be setup by placing the address of the look up data to be retrieved in the table pointer registers, TBLP and TBHP. These registers define the total address of the look-up table.

After setting up the table pointer, the table data can be retrieved from the Program Memory using the corresponding table read instruction such as “TABRD [m]” or “TABRDL [m]” respectively when the memory [m] is located in Sector 0. If the memory [m] is located in other sectors except Sector 0, the data can be retrieved from the program memory using the corresponding extended table read instruction such as “LTABRD [m]” or “LTABRDL [m]” respectively. When the instruction

is executed, the lower order table byte from the Program Memory will be transferred to the user defined Data Memory register [m] as specified in the instruction. The higher order table data byte from the Program Memory will be transferred to the TBLH special register.

The accompanying diagram illustrates the addressing data flow of the look-up table.

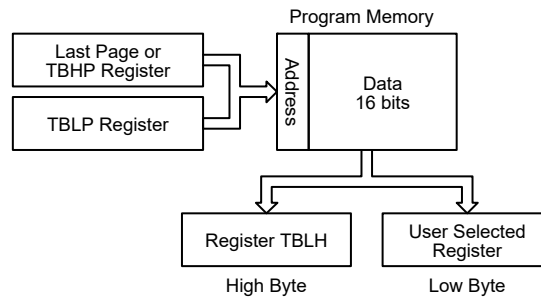

Table Program Example

The following example shows how the table pointer and table data is defined and retrieved from the microcontroller. This example uses raw table data located in the Program Memory which is stored there using the ORG statement. The value at this ORG statement is “0F00H” which refers to the start address of the last page within the 4K Program Memory of the HT67L2540A. The table pointer low byte register is setup here to have an initial value of “06H”. This will ensure that the first data read from the data table will be at the Program Memory address “0F06H” or 6 locations after the start of the last page. Note that the value for the table pointer is referenced to the specific address specified by TBLP and TBHP if the “TABRD [m]” or “LTABRD [m]” instruction is being used. The high byte of the table data which in this case is equal to zero will be transferred to the TBLH register automatically when the “TABRD [m]” or “LTABRD [m]” instruction is executed.

Because the TBLH register is a read/write register and can be restored, care should be taken to ensure its protection if both the main routine and Interrupt Service Routine use table read instructions. If using the table read instructions, the Interrupt Service Routines may change the value of the TBLH and subsequently cause errors if used again by the main routine. As a rule, it is recommended that simultaneous use of the table read instructions should be avoided. However, in situations where simultaneous use cannot be avoided, the interrupts should be disabled prior to the execution of any main routine table-read instructions. Note that all table related instructions require two instruction cycles to complete their operation.

Table Read Program Example

```

ds .section 'data'
tempreg1 db? ; temporary register #1
tempreg2 db? ; temporary register #2
:
:
mov a,06h ; initialise low table pointer - note that this address is referenced
mov tblp,a ; to the last page or the page that tbhp pointed
mov a,0Fh ; initialise high table pointer
mov tbhp,a ; it is not necessary to set tbhp if executing tabrdl or ltabrdl
:
:
tabrd tempreg1 ; transfers value in table referenced by table pointer
; data at program memory address "0F06H" transferred to tempreg1 and TBLH
dec tblp ; reduce value of table pointer by one
tabrd tempreg2 ; transfers value in table referenced by table pointer
    
```

```

; data at program memory address "0F05H" transferred to tempreg2 and TBLH
; in this example the data "1AH" is transferred to tempreg1 and data "0FH"
; to tempreg2
; the value "00H" will be transferred to the high byte register TBLH
:
org 0F00h      ; set initial address of last page
dc 00Ah,00Bh,00Ch,00Dh,00Eh,00Fh,01Ah,01Bh

```

In Circuit Programming – ICP

The provision of Flash type Program Memory provides the user with a means of convenient and easy upgrades and modifications to their programs on the same device. As an additional convenience, a means of programming the microcontroller in-circuit has provided using a 4-pin interface. This provides manufacturers with the possibility of manufacturing their circuit boards complete with a programmed or un-programmed microcontroller, and then programming or upgrading the program at a later stage. This enables product manufacturers to easily keep their manufactured products supplied with the latest program releases without removal and re-insertion of the devices.

Holtek Writer Pins	MCU Programming Pins	Pin Description
ICPDA	PA0	Programming Serial Data/Address
ICPCK	PA2	Programming Clock
VDD	VDD	Power Supply
VSS	VSS	Ground

The Program Memory can be programmed serially in-circuit using this 4-wire interface. Data is downloaded and uploaded serially on a single pin with an additional line for the clock. Two additional lines are required for the power supply. The technical details regarding the in-circuit programming of the device is beyond the scope of this document and will be supplied in supplementary literature.

During the programming process, taking control of the ICPDA and ICPCK pins for data and clock programming purposes. The user must there take care to ensure that no other outputs are connected to these two pins.

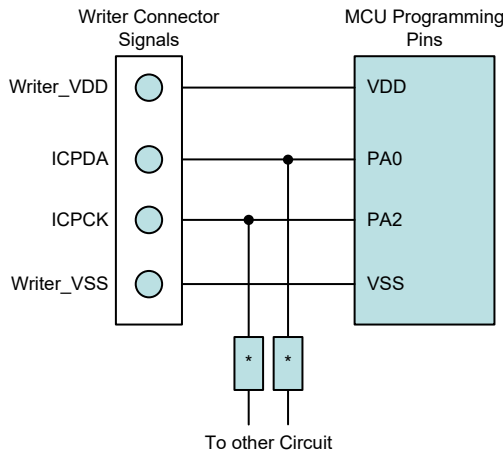

Note: * may be resistor or capacitor. The resistance of * must be greater than 1kΩ or the capacitance of * must be less than 1nF.

On-Chip Debug Support – OCDS

There are EV chips named HT67LV2540A and HT67LV2550A which are used to emulate the real MCU devices named HT67L2540A and HT67L2550A. The EV chip devices also provide an “On-Chip Debug” function to debug the real MCU devices during the development process. The EV chips and the real MCU devices are almost functionally compatible except for the “On-Chip Debug” function. Users can use the EV chip device to emulate the real chip device behavior by connecting the OCSDSA and OCDSCK pins to the Holtek HT-IDE development tools. The OCSDSA pin is the OCDS Data/Address input/output pin while the OCDSCK pin is the OCDS clock input pin. When users use the EV chip for debugging, other functions which are shared with the OCSDSA and OCDSCK pins in the actual MCU device will have no effect in the EV chip. However, the two OCDS pins which are pin-shared with the ICP programming pins are still used as the Flash Memory programming pins for ICP. For more detailed OCDS description, refer to the corresponding document named “Holtek e-Link for 8-bit MCU OCDS User’s Guide”.

Holtek e-Link Pins	EV Chip Pins	Pin Description
OCSDSA	OCSDSA	On-Chip Debug Support Data/Address input/output
OCDSCK	OCDSCK	On-Chip Debug Support Clock input
VDD	VDD	Power Supply
VSS	VSS	Ground

In Application Programming – IAP

Flash type Program Memory provides the user with a means of convenient and easy upgrades and modifications to their programs on the same device. The provision of the IAP function offers users the convenience of Flash Memory multi-programming features. The convenience of the IAP function is that it can execute the updated program procedure using its internal firmware, without requiring an external Program Writer or PC. In addition, the IAP interface can also be any type of communication protocol, such as UART, using I/O pins. Regarding the internal firmware, the user can select versions provided by Holtek or create their own. The following section illustrates the procedures regarding how to implement the IAP firmware.

Flash Memory Read/Write Size

The Flash memory Erase and Write operations are carried out in a page format while the Read operation is carried out in a word format. The page size and write buffer size are both assigned with a capacity of 32 words. Note that the Erase operation should be executed before the Write operation is executed.

When the Flash Memory Erase/Write Function is successfully enabled, the CFWEN bit will be set high. When the CFWEN bit is set high, the data can be written into the write buffer. The FWT bit is used to initiate the write process and then indicate the write operation status. This bit is set high by application programs to initiate a write process and will be cleared by hardware if the write process is finished.

The Read operation can be carried out by executing a specific read procedure. The FRDEN bit is used to enable the read function and the FRD bit is used to initiate the read process by application programs and then indicate the read operation status. When the read process is finished, this bit will be cleared by hardware.

Operations	Format
Erase	32 words/page
Write	32 words/time
Read	1 word/time
Note: Page size=Write buffer size=32 words.	

IAP Operation Format

Erase Page	FARH	FARL[7:5]	FARL[4:0]
0	0000 0000	000	x xxxx
1	0000 0000	001	x xxxx
2	0000 0000	010	x xxxx
3	0000 0000	011	x xxxx
4	0000 0000	100	x xxxx
:	:	:	:
:	:	:	:
126	0000 1111	110	x xxxx
127	0000 1111	111	x xxxx

“x”: Don't care

Erase Page Number and Selection – HT67L2540A

Erase Page	FARH	FARL[7:5]	FARL[4:0]
0	0000 0000	000	x xxxx
1	0000 0000	001	x xxxx
2	0000 0000	010	x xxxx
3	0000 0000	011	x xxxx
4	0000 0000	100	x xxxx
:	:	:	:
:	:	:	:
254	0001 1111	110	x xxxx
255	0001 1111	111	x xxxx

“x”: Don't care

Erase Page Number and Selection – HT67L2550A

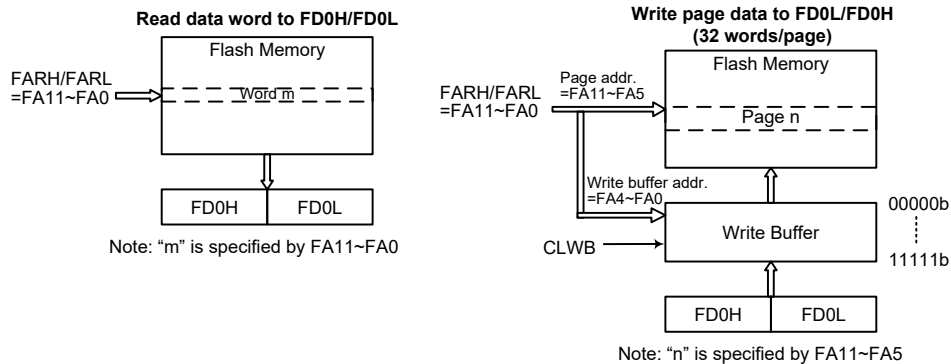

Flash Memory IAP Read/Write Structure – HT67L2540A

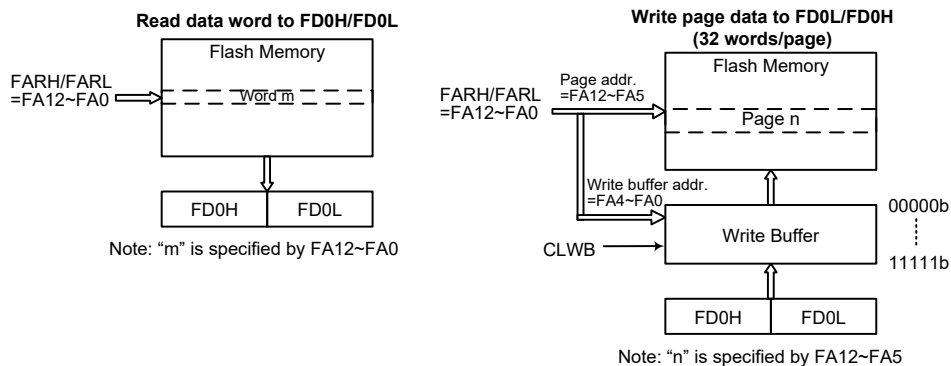

Flash Memory IAP Read/Write Structure – HT67L2550A

Write Buffer

The write buffer is used to store the written data temporarily when executing the write operation. The Write Buffer can be filled with written data after the Flash Memory Erase/Write Function has been successfully enabled by executing the Flash Memory Erase/Write Function Enable procedure. The write buffer can be cleared by configuring the CLWB bit in the FC2 register. The CLWB bit can be set high to enable the Clear Write Buffer procedure. When the procedure is finished this bit will be cleared to low by the hardware. It is recommended that the write buffer should be cleared by setting the CLWB bit high before the write buffer is used for the first time or when the data in the write buffer is updated.

The write buffer size is 32 words corresponding to a page. The write buffer address is mapped to a specific flash memory page specified by the memory address bits, FA11~FA5 or FA12~FA5. The data written into the FD0L and FD0H registers will be loaded into the write buffer. When data is written into the high byte data register, FD0H, it will result in the data stored in the high and low byte data registers both being written into the write buffer. It will also cause the flash memory address to be incremented by one, after which the new address will be loaded into the FARH and FARL address registers. When the flash memory address reaches the page boundary, 11111b of a page with 32 words, the address will now not be incremented but will stop at the last address of the page. At this point a new page address should be specified for any other erase/write operations.

After a write process is finished, the write buffer will automatically be cleared by the hardware. Note that the write buffer should be cleared manually by the application program when the data written into the flash memory is incorrect in the data verification step. The data should again be written into the write buffer after the write buffer has been cleared when the data is found to be incorrect during the data verification step.

IAP Flash Program Memory Registers

There are two address registers, four pairs of 16-bit data registers and three control registers. The address and data registers are located in Sector 0 while the control registers are located in Sector 1. Read and Write operations to the Flash memory are carried out by 16-bit data operations using the address and data registers and the control registers. Several registers control the overall operation of the internal Flash Program Memory. The address registers are named FARL and FARH, the data registers are named FDnL and FDnH, where n is equal to 0~3, and the control registers are named FC0, FC1 and FC2. As the FARH, FARL, FDnH and FDnL registers are located in Sector 0, they can be directly accessed in the same way as any other Special Function Register. The FC0, FC1 and FC2 registers, being located in Sector 1, can be can be addressed directly only using the corresponding extended instructions or can be read from or written to indirectly using the MP1H/MP1L or MP2H/MP2L Memory Pointer pairs and Indirect Addressing Register, IAR1 or IAR2.

Register Name	Bit							
	7	6	5	4	3	2	1	0
FC0	CFWEN	FMOD2	FMOD1	FMOD0	FWPEN	FWT	FRDEN	FRD
FC1	D7	D6	D5	D4	D3	D2	D1	D0
FC2	—	—	—	—	—	—	—	CLWB
FARL	FA7	FA6	FA5	FA4	FA3	FA2	FA1	FA0
FARH (HT67L2540A)	—	—	—	—	FA11	FA10	FA9	FA8
FARH (HT67L2550A)	—	—	—	FA12	FA11	FA10	FA9	FA8
FD0L	D7	D6	D5	D4	D3	D2	D1	D0
FD0H	D15	D14	D13	D12	D11	D10	D9	D8

Register Name	Bit							
	7	6	5	4	3	2	1	0
FD1L	D7	D6	D5	D4	D3	D2	D1	D0
FD1H	D15	D14	D13	D12	D11	D10	D9	D8
FD2L	D7	D6	D5	D4	D3	D2	D1	D0
FD2H	D15	D14	D13	D12	D11	D10	D9	D8
FD3L	D7	D6	D5	D4	D3	D2	D1	D0
FD3H	D15	D14	D13	D12	D11	D10	D9	D8

IAP Register List

• **FARL Register**

Bit	7	6	5	4	3	2	1	0
Name	FA7	FA6	FA5	FA4	FA3	FA2	FA1	FA0
R/W	R/W	R/W	R/W	R/W	R/W	R/W	R/W	R/W
POR	0	0	0	0	0	0	0	0

Bit 7~0 **FA7~FA0**: Flash Memory Address bit 7 ~ bit 0

• **FARH Register – HT67L2540A**

Bit	7	6	5	4	3	2	1	0
Name	—	—	—	—	FA11	FA10	FA9	FA8
R/W	—	—	—	—	R/W	R/W	R/W	R/W
POR	—	—	—	—	0	0	0	0

Bit 7~4 Unimplemented, read as “0”

Bit 3~0 **FA11~FA8**: Flash Memory Address bit 11 ~ bit 8

• **FARH Register – HT67L2550A**

Bit	7	6	5	4	3	2	1	0
Name	—	—	—	FA12	FA11	FA10	FA9	FA8
R/W	—	—	—	R/W	R/W	R/W	R/W	R/W
POR	—	—	—	0	0	0	0	0

Bit 7~5 Unimplemented, read as “0”

Bit 4~0 **FA12~FA8**: Flash Memory Address bit 12 ~ bit 8

• **FD0L Register**

Bit	7	6	5	4	3	2	1	0
Name	D7	D6	D5	D4	D3	D2	D1	D0
R/W	R/W	R/W	R/W	R/W	R/W	R/W	R/W	R/W
POR	0	0	0	0	0	0	0	0

Bit 7~0 **D7~D0**: The first Flash Memory data bit 7 ~ bit 0

Note that data written into the low byte data register FD0L will only be stored in the FD0L register and not loaded into the lower 8-bit write buffer.

• **FD0H Register**

Bit	7	6	5	4	3	2	1	0
Name	D15	D14	D13	D12	D11	D10	D9	D8
R/W	R/W	R/W	R/W	R/W	R/W	R/W	R/W	R/W
POR	0	0	0	0	0	0	0	0

Bit 7~0 **D15~D8**: The first Flash Memory data bit 15 ~ bit 8

Note that when the 8-bit data is written into the high byte data register FD0H, the whole 16 bits of data stored in the FD0H and FD0L registers will simultaneously be loaded into the 16-bit write buffer after which the contents of the Flash memory address register pair, FARH and FARL, will be incremented by one.

• **FD1L Register**

Bit	7	6	5	4	3	2	1	0
Name	D7	D6	D5	D4	D3	D2	D1	D0
R/W	R/W	R/W	R/W	R/W	R/W	R/W	R/W	R/W
POR	0	0	0	0	0	0	0	0

Bit 7~0 **D7~D0**: The second Flash Memory data bit 7 ~ bit 0

• **FD1H Register**

Bit	7	6	5	4	3	2	1	0
Name	D15	D14	D13	D12	D11	D10	D9	D8
R/W	R/W	R/W	R/W	R/W	R/W	R/W	R/W	R/W
POR	0	0	0	0	0	0	0	0

Bit 7~0 **D15~D8**: The second Flash Memory data bit 15 ~ bit 8

• **FD2L Register**

Bit	7	6	5	4	3	2	1	0
Name	D7	D6	D5	D4	D3	D2	D1	D0
R/W	R/W	R/W	R/W	R/W	R/W	R/W	R/W	R/W
POR	0	0	0	0	0	0	0	0

Bit 7~0 **D7~D0**: The third Flash Memory data bit 7 ~ bit 0

• **FD2H Register**

Bit	7	6	5	4	3	2	1	0
Name	D15	D14	D13	D12	D11	D10	D9	D8
R/W	R/W	R/W	R/W	R/W	R/W	R/W	R/W	R/W
POR	0	0	0	0	0	0	0	0

Bit 7~0 **D15~D8**: The third Flash Memory data bit 15 ~ bit 8

• **FD3L Register**

Bit	7	6	5	4	3	2	1	0
Name	D7	D6	D5	D4	D3	D2	D1	D0
R/W	R/W	R/W	R/W	R/W	R/W	R/W	R/W	R/W
POR	0	0	0	0	0	0	0	0

Bit 7~0 **D7~D0**: The fourth Flash Memory data bit 7 ~ bit 0

• **FD3H Register**

Bit	7	6	5	4	3	2	1	0
Name	D15	D14	D13	D12	D11	D10	D9	D8
R/W	R/W	R/W	R/W	R/W	R/W	R/W	R/W	R/W
POR	0	0	0	0	0	0	0	0

Bit 7~0 **D15~D8**: The fourth Flash Memory data bit 15 ~ bit 8

• **FC0 Register**

Bit	7	6	5	4	3	2	1	0
Name	CFWEN	FMOD2	FMOD1	FMOD0	FWPEN	FWT	FRDEN	FRD
R/W	R/W	R/W	R/W	R/W	R/W	R/W	R/W	R/W
POR	0	0	0	0	0	0	0	0

Bit 7 **CFWEN**: Flash Memory Erase/Write function enable control
 0: Flash Memory erase/write function is disabled
 1: Flash Memory erase/write function has been successfully enabled
 When this bit is cleared to zero by application program, the Flash Memory erase/write function is disabled. Note that this bit cannot be set high by application programs. Writing “1” into this bit results in no action. This bit is used to indicate that the Flash Memory erase/write function status. When this bit is set high by hardware, it means that the Flash Memory erase/write function is enabled successfully. Otherwise, the Flash Memory erase/write function is disabled as the bit content is zero.

Bit 6~4 **FMOD2~FMOD0**: Flash Memory Mode selection
 000: Write Mode
 001: Page Erase Mode
 010: Reserved
 011: Read Mode
 100: Reserved
 101: Reserved
 110: Flash Memory Erase/Write function Enable Mode
 111: Reserved
 These bits are used to select the Flash Memory operation modes. Note that the “Flash memory Erase/Write function Enable Mode” should first be successfully enabled before the Erase or Write Flash memory operation is executed.

Bit 3 **FWPEN**: Flash Memory Erase/Write function enable procedure trigger
 0: Erase/Write function enable procedure is not triggered or procedure timer times out
 1: Erase/Write function enable procedure is triggered and procedure timer starts to count
 This bit is used to activate the flash memory Erase/Write function enable procedure and an internal timer. It is set by the application programs and then cleared to zero by the hardware when the internal timer times out. The correct patterns must be written into the FD1L/FD1H, FD2L/FD2H and FD3L/FD3H register pairs respectively as soon as possible after the FWPEN bit is set high.

Bit 2 **FWT**: Flash Memory write initiate control bit
 0: Do not initiate Flash Memory write or indicating that a Flash Memory write process has completed
 1: Initiate a Flash Memory write process
 This bit is set by software and cleared to zero by the hardware when the Flash memory write process has completed.

Bit 1 **FRDEN**: Flash Memory read enabled bit
 0: Flash Memory read disable
 1: Flash Memory read enable
 This is the Flash memory Read Enable bit which must be set high before any Flash memory read operations are carried out. Clearing this bit to zero will inhibit Flash memory read operations.

Bit 0 **FRD**: Flash Memory read control bit
 0: Do not initiate Flash Memory read or indicating that a Flash Memory read process has completed
 1: Initiate a Flash Memory read process
 This bit is set by software and cleared to zero by the hardware when the Flash memory read process has completed.

- Note: 1. The FWT, FRDEN and FRD bits cannot be set to “1” at the same time with a single instruction.
 2. Ensure that the f_{SUB} clock is stable before executing the erase or write operation.
 3. Note that the CPU will be stopped when a read, erase or write operation is successfully activated.
 4. Ensure that the read, erase or write operation is totally complete before executing other operations.

• **FC1 Register**

Bit	7	6	5	4	3	2	1	0
Name	D7	D6	D5	D4	D3	D2	D1	D0
R/W	R/W	R/W	R/W	R/W	R/W	R/W	R/W	R/W
POR	0	0	0	0	0	0	0	0

Bit 7~0 **D7~D0**: Chip Reset Pattern
 When a specific value of “55H” is written into this register, a reset signal will be generated to reset the whole chip.

• **FC2 Register**

Bit	7	6	5	4	3	2	1	0
Name	—	—	—	—	—	—	—	CLWB
R/W	—	—	—	—	—	—	—	R/W
POR	—	—	—	—	—	—	—	0

Bit 7~1 Unimplemented, read as “0”
 Bit 0 **CLWB**: Flash Memory Write buffer clear control
 0: Do not initiate a Write Buffer Clear process or indicating that a Write Buffer Clear process has completed
 1: Initiate a Write Buffer Clear process
 This bit is set by software and cleared to zero by hardware when the Write Buffer Clear process has completed.

Flash Memory Erase/Write Flow

It is important to understand the Flash memory Erase/Write flow before the Flash memory contents are updated. Users can refer to the corresponding operation procedures when developing their IAP program to ensure that the flash memory contents are correctly updated.

Flash Memory Erase/Write Flow Descriptions

1. Activate the “Flash Memory Erase/Write function enable procedure” first. When the Flash Memory Erase/Write function is successfully enabled, the CFWEN bit in the FC0 register will automatically be set high by hardware. After this, Erase or Write operations can be executed on the Flash memory. Refer to the “Flash Memory Erase/Write Function Enable Procedure” for details.
2. Configure the flash memory address to select the desired erase page and then erase this page.
3. Execute a Blank Check operation to ensure whether the page erase operation is successful or not. The “TABRD” instruction should be executed to read the flash memory contents and to check if the contents is 0000h or not. If the flash memory page erase operation fails, users should go back to Step 2 and execute the page erase operation again.
4. Write data into the specific page. Refer to the “Flash Memory Write Procedure” for details.
5. Execute the “TABRD” instruction to read the flash memory contents and check if the written data is correct or not. If the data read from the flash memory is different from the written data, it means that the page write operation has failed. The CLWB bit should be set high to clear the write buffer and then write the data into the specific page again if the write operation has failed.
6. Clear the CFWEN bit to disable the Flash Memory Erase/Write function enable mode if the current page Erase and Write operations are completed and no more pages need to be erased or written.

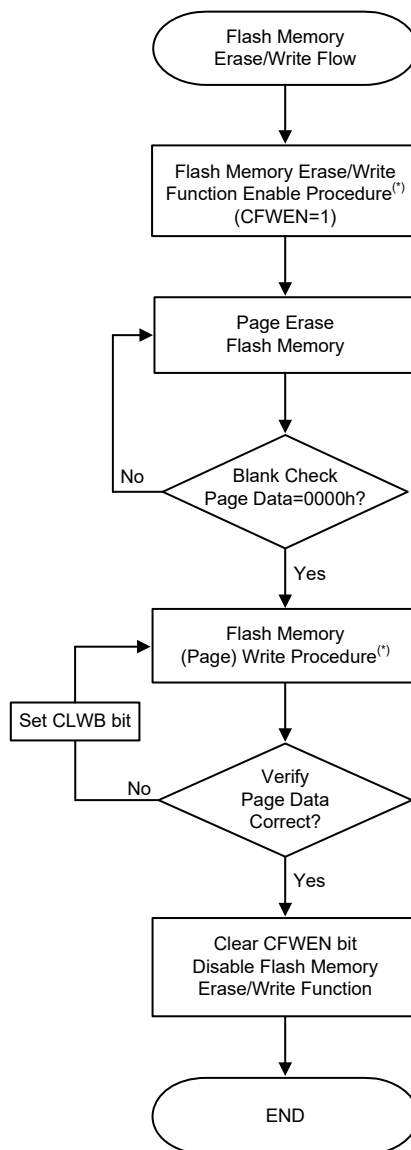

Flash Memory Erase/Write Flow

Note: The Flash Memory Erase/Write Function Enable procedure and Flash Memory Write procedure will be described in the following sections.

Flash Memory Erase/Write Function Enable Procedure

The Flash Memory Erase/Write Function Enable Mode is specially designed to prevent the Flash Memory contents from being wrongly modified. In order to allow users to change the Flash memory data using the IAP control registers, users must first enable the Flash Memory Erase/Write function.

Flash Memory Erase/Write Function Enable Procedure Description

1. Write data “110” to the FMOD [2:0] bits in the FC0 register to select the Flash Memory Erase/Write Function Enable Mode.
2. Set the FWPEN bit in the FC0 register to “1” to activate the Flash Memory Erase/Write Enable Function. This will also activate an internal timer.
3. Write the correct data pattern into the Flash data registers, FD1L~FD3L and FD1H~FD3H, as soon as possible after the FWPEN bit is set high. The data pattern to enable Flash memory erase/write function is 00H, 0DH, C3H, 04H, 09H and 40H corresponding to the FD1L~FD3L and FD1H~FD3H registers respectively.
4. Once the timer has timed out, the FWPEN bit will automatically be cleared to zero by hardware regardless of the input data pattern.
5. If the written data pattern is incorrect, the Flash memory erase/write function will not be enabled successfully and the above steps should be repeated. If the written data pattern is correct, the Flash memory erase/write function will be enabled successfully.
6. Once the Flash memory erase/write function is enabled, the Flash memory contents can be updated by executing the page erase and write operations using the IAP control registers.

To disable the Flash memory erase/write function, the CFWEN bit in the FC0 register can be cleared. There is no need to execute the above procedure.

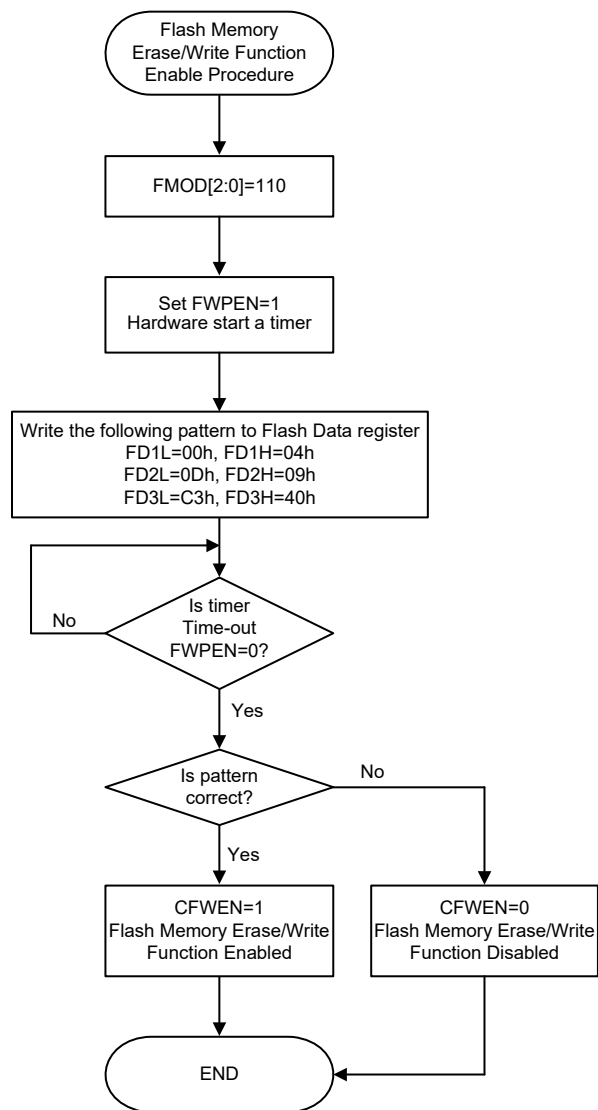

Flash Memory Erase/Write Function Enable Procedure

Flash Memory Write Procedure

After the Flash memory erase/write function has been successfully enabled as the CFWEN bit is set high, the data to be written into the flash memory can be loaded into the write buffer. The selected flash memory page data should be erased by properly configuring the IAP control registers before the data write procedure is executed.

The write buffer size is 32 words, known as a page, whose address is mapped to a specific flash memory page specified by the memory address bits, FA11~FA5 or FA12~FA5. It is important to ensure that the page where the write buffer data is located is the same one which the memory address bits, FA11~FA5 or FA12~FA5, specify.

Flash Memory Consecutive Write Description

The maximum amount of write data is 32 words for each write operation. The write buffer address will be automatically incremented by one when consecutive write operations are executed. The start address of a specific page should first be written into the FARL and FARH registers. Then the data word should first be written into the FD0L register and then the FD0H register. At the same time the write buffer address will be incremented by one and then the next data word can be written into the FD0L and FD0H registers for the next address without modifying the address register pair, FARH and FARL. When the write buffer address reaches the page boundary the address will not be further incremented but will stop at the last address of the page.

1. Activate the “Flash Memory Erase/Write function enable procedure”. Check the CFWEN bit value and then execute the erase/write operations if the CFWEN bit is set high. Refer to the “Flash Memory Erase/Write function enable procedure” for more details.
2. Set the FMOD [2:0] bits to “001” to select the erase operation. Set the FWT bit high to erase the desired page which is specified by the FARH and FARL registers. Wait until the FWT bit goes low.
3. Execute a Blank Check operation using the table read instruction to ensure that the erase operation has successfully completed.
Go to step 2 if the erase operation is not successful.
Go to step 4 if the erase operation is successful.
4. Set the FMOD [2:0] bits to “000” to select the write operation.
5. Setup the desired start address in the FARH and FARL registers. Write the desired data words consecutively into the FD0L and FD0H registers within a page as specified by their consecutive addresses. The maximum written data number is 32 words.
6. Set the FWT bit high to write the data words from the write buffer to the flash memory. Wait until the FWT bit goes low.
7. Verify the data using the table read instruction to ensure that the write operation has successfully completed.
If the write operation has not successfully completed, set the CLWB bit high to clear the write buffer and then go to step 5.
Go to step 8 if the write operation is successful.
8. Clear the CFWEN bit low to disable the Flash memory erase/write function.

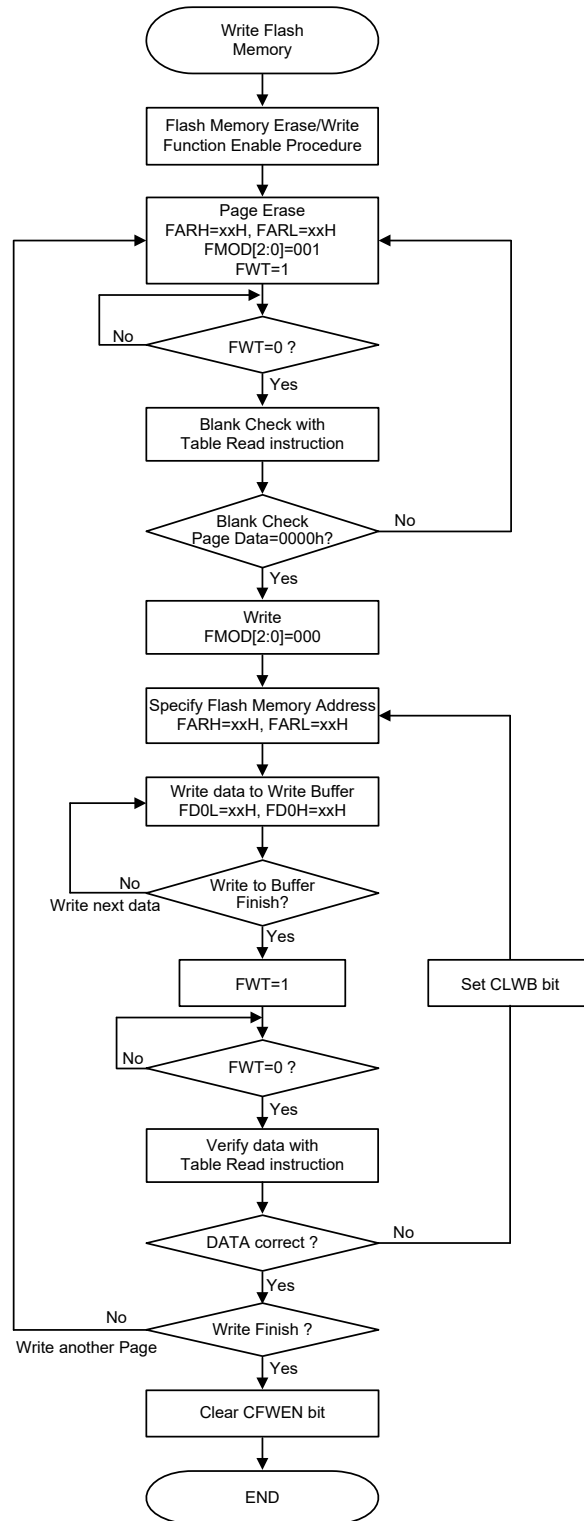

Flash Memory Consecutive Write Procedure

- Note: 1. When the erase or write operation is successfully activated, all CPU operations will temporarily cease.
2. It will take a typical time of 2.2ms for the FWT bit state changing from high to low.

Flash Memory Non-Consecutive Write Description

The main difference between Flash Memory Consecutive and Non-Consecutive Write operations is whether the data words to be written are located in consecutive addresses or not. If the data to be written is not located in consecutive addresses the desired address should be re-assigned after a data word is successfully written into the Flash Memory.

A two data word non-consecutive write operation is taken as an example here and described as follows:

1. Activate the “Flash Memory Erase/Write function enable procedure”. Check the CFWEN bit value and then execute the erase/write operation if the CFWEN bit is set high. Refer to the “Flash Memory Erase/Write function enable procedure” for more details.
2. Set the FMOD [2:0] bits to “001” to select the erase operation. Set the FWT bit high to erase the desired page which is specified by the FARH and FARL registers. Wait until the FWT bit goes low.
3. Execute a Blank Check operation using the table read instruction to ensure that the erase operation has successfully completed.
Go to step 2 if the erase operation is not successful.
Go to step 4 if the erase operation is successful.
4. Set the FMOD [2:0] bits to “000” to select the write operation.
5. Setup the desired address ADDR1 in the FARH and FARL registers. Write the desired data word DATA1 first into the FD0L register and then into the FD0H register.
6. Set the FWT bit high to transfer the data word from the write buffer to the flash memory. Wait until the FWT bit goes low.
7. Verify the data using the table read instruction to ensure that the write operation has successfully completed.
If the write operation has not successfully completed, set the CLWB bit high to clear the write buffer and then go to step 5.
Go to step 8 if the write operation is successful.
8. Set the desired address ADDR2 in the FARH and FARL registers. Write the desired data word DATA2 first into the FD0L register and then into the FD0H register.
9. Set the FWT bit high to transfer the data word from the write buffer to the flash memory. Wait until the FWT bit goes low.
10. Verify the data using the table read instruction to ensure that the write operation has successfully completed.
If the write operation has not successfully completed, set the CLWB bit high to clear the write buffer and then go to step 8.
Go to step 11 if the write operation is successful.
11. Clear the CFWEN bit low to disable the Flash memory erase/write function.

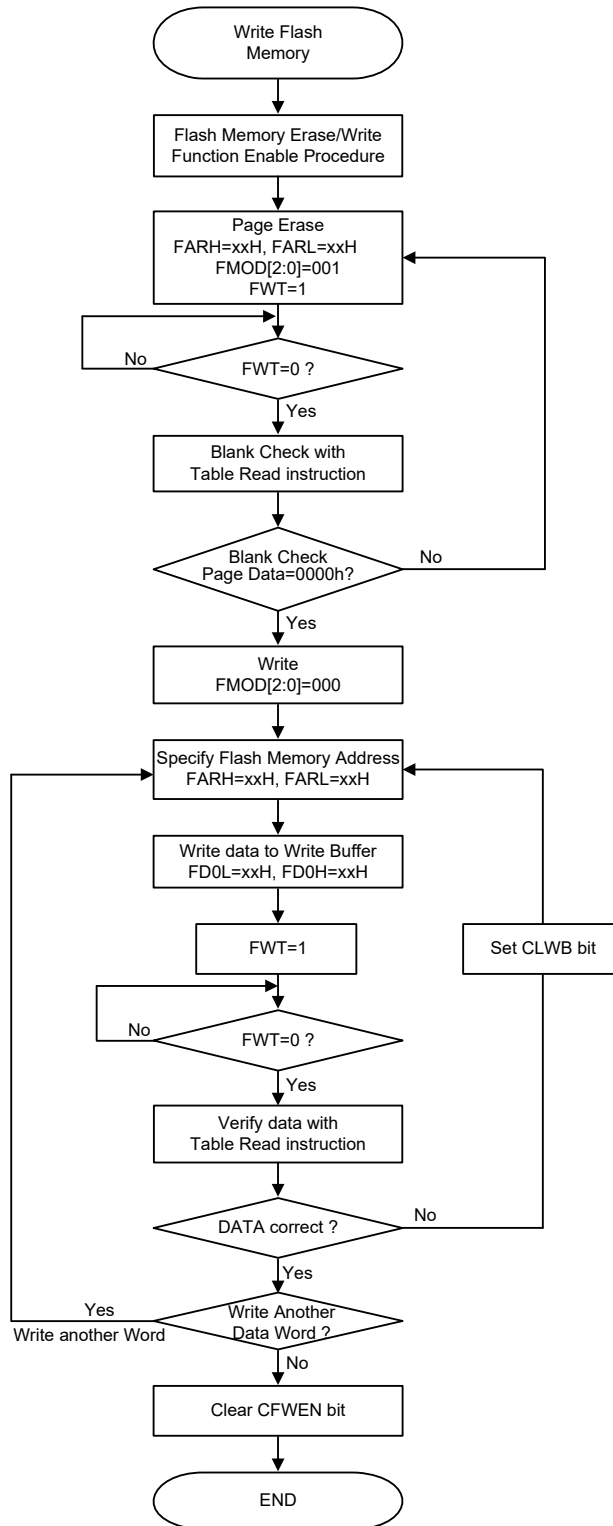

Flash Memory Non-Consecutive Write Procedure

- Note: 1. When the erase or write operation is successfully activated, all CPU operations will temporarily cease.
2. It will take a typical time of 2.2ms for the FWT bit state changing from high to low.

Important Points to Note for Flash Memory Write Operations

1. The “Flash Memory Erase/Write Function Enable Procedure” must be successfully activated before the Flash Memory erase/write operation is executed.
2. The Flash Memory erase operation is executed to erase a whole page.
3. The whole write buffer data will be written into the flash memory in a page format. The corresponding address cannot exceed the page boundary.
4. After the data is written into the Flash memory the Flash memory contents must be read out using the table read instruction, TABRD, and checked if it is correct or not. If the data written into the Flash memory is incorrect, the write buffer should be cleared by setting the CLWB bit high and then write the data again into the write buffer. Then activate a write operation on the same Flash memory page without erasing it. The data check, buffer clear and data re-write steps should be repeatedly executed until the data written into the flash memory is correct.
5. The system frequency should be setup to the maximum application frequency when data write and data check operations are executed using the IAP function.

Flash Memory Read Procedure

To activate the Flash Memory Read procedure, the FMODE [2:0] bits should be set to “011” to select the Flash memory read mode and the FRDEN bit should be set high to enable the read function. The desired Flash memory address should be written into the FARH and FARL registers and then the FRD bit should be set high. After this the Flash memory read operation will be activated. The data stored in the specified address can be read from the data registers, FDOH and FDOL, when the FRD bit goes low. There is no need to first activate the Flash Memory Erase/Write Function Enable Procedure before the Flash memory read operation is executed.

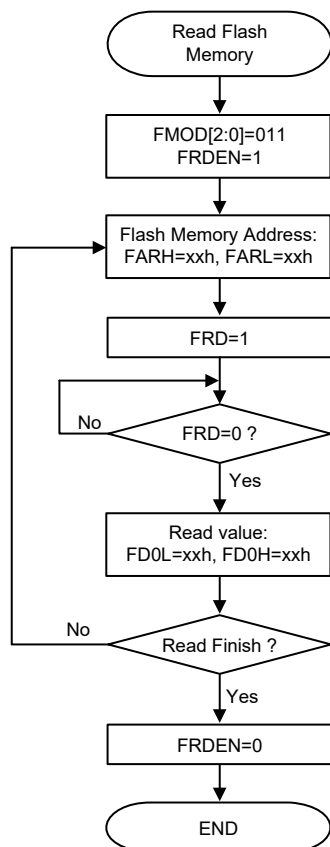

Flash Memory Read Procedure

- Note: 1. When the read operation is successfully activated, all CPU operations will temporarily cease.
2. It will take a typical time of three instruction cycles for the FRD bit state changing from high to low.

Data Memory

The Data Memory is a volatile area of 8-bit wide RAM internal memory and is the location where temporary information is stored.

Categorized into three types, the first of these is an area of RAM where special function registers are located. These registers have fixed locations and are necessary for correct operation of the device. Many of these registers can be read from and written to directly under program control, however, some remain protected from user manipulation. The second area of Data Memory is reserved for general purpose use. All locations within this area are read and write accessible under program control. The third area is reserved for the LCD Data Memory. This special area will directly affect the displayed data.

Switching between the different Data Memory sectors is achieved by properly setting the Memory Pointers to correct value if using the indirect addressing method.

Structure

The Data Memory is subdivided into several sectors, all of which are implemented in 8-bit wide RAM. Each of the Data Memory Sector is categorized into two types, the special Purpose Data Memory and the General Purpose Data Memory. The address range of the Special Purpose Data Memory for the device is from 00H to 7FH while the General Purpose Data Memory address range is from 80H to FFH except the LCD Display Data Memory. The HT67L2540A LCD Display Data Memory is located from 00H to 17H in the Sector 4. For the HT67L2550A, the LCD Display Data Memory is located from 00H to 1FH in the Sector 4.

Device	Special Purpose Data Memory	General Purpose Data Memory		LCD Display Data Memory
	Located Sectors	Capacity	Sector: Address	Sector: Address
HT67L2540A	0, 1	256×8	0: 80H~FFH 1: 80H~FFH	4: 00H~17H
HT67L2550A	0, 1	512×8	0: 80H~FFH 1: 80H~FFH 2: 80H~FFH 3: 80H~FFH	4: 00H~1FH

Data Memory Summary

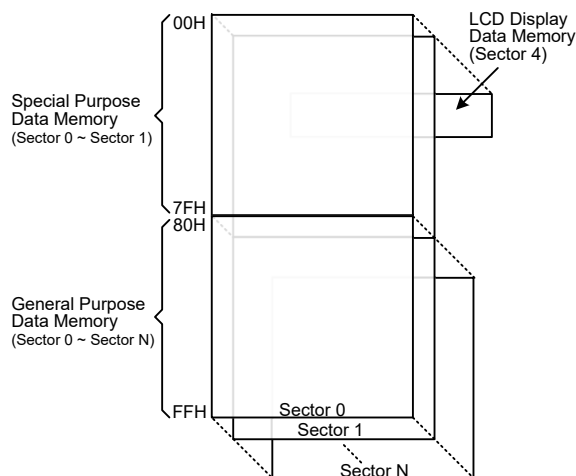

Note: N=1, and Sector 4: 00H~17H for HT67L2540A LCD Display Data Memory;
N=3, and Sector 4: 00H~1FH for HT67L2550A LCD Display Data Memory.

Data Memory Structure

Data Memory Addressing

For the devices that support the extended instructions, there is no Bank Pointer for Data Memory addressing. The desired Sector is pointed by the MP1H or MP2H register and the certain Data Memory address in the selected sector is specified by the MP1L or MP2L register when using indirect addressing access.

Direct Addressing can be used in all sectors using the corresponding instructions which can address all available data memory space. For the accessed data memory which is located in any data memory sectors except sector 0, the extended instructions can be used to access the data memory instead of using the indirect addressing access. The main difference between standard instructions and extended instructions is that the data memory address “m” in the extended instructions has up to 10 valid bits for the devices, the high byte indicates a sector and the low byte indicates a specific address.

General Purpose Data Memory

All microcontroller programs require an area of read/write memory where temporary data can be stored and retrieved for use later. It is this area of RAM memory that is known as General Purpose Data Memory. This area of Data Memory is fully accessible by the user programing for both reading and writing operations. By using the bit operation instructions individual bits can be set or reset under program control giving the user a large range of flexibility for bit manipulation in the Data Memory.

Special Purpose Data Memory

This area of Data Memory is where registers, necessary for the correct operation of the microcontroller, are stored. Most of the registers are both readable and writeable but some are protected and are readable only, the details of which are located under the relevant Special Function Register section. Note that for locations that are unused, any read instruction to these addresses will return the value “00H”.

Sector 0		Sector 1	Sector 0		Sector 1	
00H	IAR0	[Unused]	40H	LVDC	EEC	
01H	MP0		41H	EEA		
02H	IAR1		42H			
03H	MP1L		43H	EED	FC0	
04H	MP1H		44H	[Unused]	FC1	
05H	ACC		45H		FC2	
06H	PCL		46H			
07H	TBLP		47H			
08H	TBLH		48H		IFS0	
09H	TBHP		49H		IFS1	
0AH	STATUS		4AH		IFS2	
0BH			4BH			
0CH	IAR2		4CH			
0DH	MP2L		4DH		PAS0	
0EH	MP2H		4EH		STMC0	PAS1
0FH	RSTFC		4FH		STMC1	PBS0
10H	INTC0		50H	STMDL	PBS1	
11H	INTC1		51H	STMDH	PCS0	
12H	INTC2		52H	STMAL	PCS1	
13H			53H	STMAH	[Unused]	
14H	PA		54H	STMRP		
15H	PAC		55H			
16H	PAPU		56H			
17H	PAWU		57H	SADC0		
18H	PB		58H	SADC1		
19H	PBC		59H	SADC2		
1AH	PBPU		5AH	SADOL		
1BH	PC		5BH	SADOH		
1CH	PCC		5CH	[Reserved]		
1DH	PCPU		5DH	[Reserved]		
1EH	[Unused]		5EH	[Reserved]		
1FH				5FH	[Reserved]	
20H				60H	PSC0R	LCDC0
21H				61H	TB0C	LCDC1
22H				62H	TB1C	LCDC2
23H				63H	PSC1R	[Unused]
24H				64H	PCRL	
25H				65H	PCRH	
26H				66H	STKPTR	
27H				67H	CRCCR	
28H				68H	CRCIN	
29H				69H	CRCDL	
2AH			6AH	CRCDH		
2BH			6BH			
2CH		6CH	SIMC0			
2DH	PMPS	6DH	SIMC1/UUCR1			
2EH	RSTC	6EH	UTXR_RXR/SIMD			
2FH	IECC	6FH	SIMA/SIMC2/UUCR2			
30H	LVPUC	70H	UUCR3			
31H		71H	SIMTOC/UBRG			
32H		72H	UUSR			
33H	MF10	73H				
34H	MF11	74H	FARL			
35H	MF12	75H	FARH			
36H		76H	FD0L			
37H		77H	FD0H			
38H		78H	FD1L			
39H	INTEG	79H	FD1H			
3AH	SCC	7AH	FD2L			
3BH	IRCC	7BH	FD2H			
3CH	HXTC	7CH	FD3L			
3DH	LXTC	7DH	FD3H			
3EH	WDTC	7EH	ORMC			
3FH	LVRC	7FH				

[Grey Box] : Unused, read as 00H

[Cross-hatched Box] : Reserved, cannot be changed

Special Purpose Data Memory Structure – HT67L2540A

Sector 0		Sector 1	Sector 0		Sector 1
00H	IAR0		40H	LVDC	EEC
01H	MP0		41H	EEAL	
02H	IAR1		42H	EEAH	
03H	MP1L		43H	EED	FC0
04H	MP1H		44H		FC1
05H	ACC		45H		FC2
06H	PCL		46H		
07H	TBLP		47H		
08H	TBLH		48H		IFS0
09H	TBHP		49H		IFS1
0AH	STATUS		4AH		IFS2
0BH			4BH		
0CH	IAR2		4CH		
0DH	MP2L		4DH		PAS0
0EH	MP2H		4EH	STMC0	PAS1
0FH	RSTFC		4FH	STMC1	PBS0
10H	INTC0		50H	STMDL	PBS1
11H	INTC1		51H	STMDH	PCS0
12H	INTC2		52H	STMAL	PCS1
13H			53H	STMAH	PDS0
14H	PA		54H	STMRP	
15H	PAC		55H		
16H	PAPU		56H		
17H	PAWU		57H	SADC0	
18H	PB		58H	SADC1	
19H	PBC		59H	SADC2	
1AH	PBPU		5AH	SADOL	
1BH	PC		5BH	SADOH	
1CH	PCC		5CH		
1DH	PCPU		5DH		
1EH	PD		5EH		
1FH	PDC		5FH		
20H	PDPU		60H	PSC0R	LCDC0
21H			61H	TB0C	LCDC1
22H		PTM0C0	62H	TB1C	LCDC2
23H		PTM0C1	63H	PSC1R	
24H		PTM0DL	64H	PCRL	
25H		PTM0DH	65H	PCRH	
26H		PTM0AL	66H	STKPTR	
27H		PTM0AH	67H	CRCCR	
28H		PTM0RPL	68H	CRCIN	
29H		PTM0RPH	69H	CRCDL	
2AH		PTM1C0	6AH	CRCDH	
2BH		PTM1C1	6BH		
2CH		PTM1DL	6CH	SIMC0	
2DH	PMPS	PTM1DH	6DH	SIMC1/UUCR1	
2EH	RSTC	PTM1AL	6EH	UTXR_RXR/SIMD	
2FH	IECC	PTM1AH	6FH	SIMA/SIMC2/UUCR2	
30H	LVPUC	PTM1RPL	70H	UUCR3	
31H		PTM1RPH	71H	SIMTOC/UBRG	
32H			72H	UUSR	
33H	MF10		73H		
34H	MF11		74H	FARL	
35H	MF12		75H	FARH	
36H			76H	FD0L	
37H			77H	FD0H	
38H			78H	FD1L	
39H	INTEG		79H	FD1H	
3AH	SCC		7AH	FD2L	
3BH	IRCC		7BH	FD2H	
3CH	HXTC		7CH	FD3L	
3DH	LXTC		7DH	FD3H	
3EH	WDTC		7EH	ORMC	
3FH	LVRC	TLVRC	7FH		

□ : Unused, read as 00H

▣ : Reserved, cannot be changed

Special Purpose Data Memory Structure – HT67L2550A

Special Function Register Description

Most of the Special Function Register details will be described in the relevant functional sections; however several registers require a separate description in this section.

Indirect Addressing Registers – IAR0, IAR1, IAR2

The Indirect Addressing Registers, IAR0, IAR1 and IAR2, although having their locations in normal RAM register space, do not actually physically exist as normal registers. The method of indirect addressing for RAM data manipulation uses these Indirect Addressing Registers and Memory Pointers, in contrast to direct memory addressing, where the actual memory address is specified. Actions on the IAR0, IAR1 and IAR2 registers will result in no actual read or write operation to these registers but rather to the memory location specified by their corresponding Memory Pointers, MP0, MP1L/MP1H or MP2L/MP2H. Acting as a pair, IAR0 and MP0 can together access data only from Sector 0 while the IAR1 register together with the MP1L/MP1H register pair and IAR2 register together with the MP2L/MP2H register pair can access data from any Data Memory Sector. As the Indirect Addressing Registers are not physically implemented, reading the Indirect Addressing Registers will return a result of “00H” and writing to the registers will result in no operation.

Memory Pointers – MP0, MP1L, MP1H, MP2L, MP2H

Five Memory Pointers, known as MP0, MP1L, MP1H, MP2L, MP2H, are provided. These Memory Pointers are physically implemented in the Data Memory and can be manipulated in the same way as normal registers providing a convenient way with which to address and track data. When any operation to the relevant Indirect Addressing Registers is carried out, the actual address that the microcontroller is directed to is the address specified by the related Memory Pointer. MP0, together with Indirect Addressing Register, IAR0, are used to access data from Sector 0, while MP1L/MP1H together with IAR1 and MP2L/MP2H together with IAR2 are used to access data from all sectors according to the corresponding MP1H or MP2H register. Direct Addressing can be used in all sectors using the extended instructions which can address all available data memory space.

The following example shows how to clear a section of four Data Memory locations already defined as locations `adres1` to `adres4`.

Indirect Addressing Program Example 1

```
data .section 'data'
adres1 db ?
adres2 db ?
adres3 db ?
adres4 db ?
block db ?
code .section at 0 code
org 00h
start:
    mov a,04h                ; setup size of block
    mov block,a
    mov a,offset adres1     ; Accumulator loaded with first RAM address
    mov mp0,a              ; setup memory pointer with first RAM address
loop:
    clr IAR0                ; clear the data at address defined by MP0
    inc mp0                 ; increment memory pointer
    sdz block               ; check if last memory location has been cleared
    jmp loop
continue:
```

Indirect Addressing Program Example 2

```
data .section 'data'
adres1 db ?
adres2 db ?
adres3 db ?
adres4 db ?
block db ?
code .section at 0 'code'
org 00h
start:
    mov a,04h                ; setup size of block
    mov block,a
    mov a,01h                ; setup the memory sector
    mov mp1h,a
    mov a,offset adres1     ; Accumulator loaded with first RAM address
    mov mp1l,a              ; setup memory pointer with first RAM address
loop:
    clr IAR1                 ; clear the data at address defined by MP1L
    inc mp1l                 ; increment memory pointer MP1L
    sdz block                ; check if last memory location has been cleared
    jmp loop
continue:
:
```

The important point to note here is that in the example shown above, no reference is made to specific RAM addresses.

Direct Addressing Program Example using extended instructions

```
data .section 'data'
temp db ?
code .section at 0 code
org 00h
start:
    lmov a,[m]               ; move [m] data to acc
    lsub a, [m+1]            ; compare [m] and [m+1] data
    snz c                    ; [m]>[m+1]?
    jmp continue            ; no
    lmov a,[m]               ; yes, exchange [m] and [m+1] data
    mov temp,a
    lmov a,[m+1]
    lmov [m],a
    mov a,temp
    lmov [m+1],a
continue:
:
```

Note: Here “m” is a data memory address located in any data memory sectors. For example, m=1F0H, it indicates address 0F0H in Sector 1.

Accumulator – ACC

The Accumulator is central to the operation of any microcontroller and is closely related with operations carried out by the ALU. The Accumulator is the place where all intermediate results from the ALU are stored. Without the Accumulator it would be necessary to write the result of each calculation or logical operation such as addition, subtraction, shift, etc., to the Data Memory resulting in higher programming and timing overheads. Data transfer operations usually involve the temporary storage function of the Accumulator; for example, when transferring data between one user-defined register and another, it is necessary to do this by passing the data through the Accumulator as no direct transfer between two registers is permitted.

Program Counter Low Byte Register – PCL

To provide additional program control functions, the low byte of the Program Counter is made accessible to programmers by locating it within the Special Purpose area of the Data Memory. By manipulating this register, direct jumps to other program locations are easily implemented. Loading a value directly into this PCL register will cause a jump to the specified Program Memory location, however, as the register is only 8-bit wide, only jumps within the current Program Memory page are permitted. When such operations are used, note that a dummy cycle will be inserted.

Look-up Table Registers – TBLP, TBHP, TBLH

These three special function registers are used to control operation of the look-up table which is stored in the Program Memory. TBLP and TBHP are the table pointers and indicate the location where the table data is located. Their value must be setup before any table read commands are executed. Their value can be changed, for example using the “INC” or “DEC” instructions, allowing for easy table data pointing and reading. TBLH is the location where the high order byte of the table data is stored after a table read data instruction has been executed. Note that the lower order table data byte is transferred to a user defined location.

Option Memory Mapping Register – ORMC

The ORMC register is used to enable Option Memory Mapping function. The Option Memory capacity is 32 words. When a specific pattern of 55H and AAH is consecutively written into this register, the Option Memory Mapping function will be enabled and then the Option Memory code can be read by using the table read instruction. The Option Memory addresses 00H~1FH will be mapped to Program Memory last page addresses E0H~FFH.

To successfully enable the Option Memory Mapping function, the specific pattern of 55H and AAH must be written into the ORMC register in two consecutive instruction cycles. It is therefore recommended that the global interrupt bit EMI should first be cleared before writing the specific pattern, and then set high again at a proper time according to users’ requirements after the pattern is successfully written. An internal timer will be activated when the pattern is successfully written. The mapping operation will be automatically finished after a period of $4 \times t_{LIRC}$. Therefore, users should read the data in time, otherwise the Option Memory Mapping function needs to be restarted. After the completion of each consecutive write operation to the ORMC register, the timer will recount.

When the table read instructions are used to read the Option Memory code, both “TABRD [m]” and “TABRDL [m]” instructions can be used. However, care must be taken if the “TABRD [m]” instruction is used, the table pointer defined by the TBHP register must be referenced to the last page. Refer to corresponding sections about the table read instruction for more details.

• ORMC Register

Bit	7	6	5	4	3	2	1	0
Name	ORMC7	ORMC6	ORMC5	ORMC4	ORMC3	ORMC2	ORMC1	ORMC0
R/W	R/W	R/W	R/W	R/W	R/W	R/W	R/W	R/W
POR	0	0	0	0	0	0	0	0

Bit 7~0 **ORMC7~ORMC0:** Option Memory Mapping specific pattern
When a specific pattern of 55H and AAH is written into this register, the Option Memory Mapping function will be enabled. Note that the register content will be cleared after the MCU is woken up from the IDLE/SLEEP mode.

Status Register – STATUS

This 8-bit register contains the SC flag, CZ flag, zero flag (Z), carry flag (C), auxiliary carry flag (AC), overflow flag (OV), power down flag (PDF), and watchdog time-out flag (TO). These arithmetic/logical operation and system management flags are used to record the status and operation of the microcontroller.

With the exception of the TO and PDF flags, bits in the status register can be altered by instructions like most other registers. Any data written into the status register will not change the TO or PDF flag. In addition, operations related to the status register may give different results due to the different instruction operations. The TO flag can be affected only by a system power-up, a WDT time-out or by executing the “CLR WDT” or “HALT” instruction. The PDF flag is affected only by executing the “HALT” or “CLR WDT” instruction or during a system power-up.

The Z, OV, AC, C, SC and CZ flags generally reflect the status of the latest operations.

- C is set if an operation results in a carry during an addition operation or if a borrow does not take place during a subtraction operation; otherwise C is cleared. C is also affected by a rotate through carry instruction.
- AC is set if an operation results in a carry out of the low nibbles in addition, or no borrow from the high nibble into the low nibble in subtraction; otherwise AC is cleared.
- Z is set if the result of an arithmetic or logical operation is zero; otherwise Z is cleared.
- OV is set if an operation results in a carry into the highest-order bit but not a carry out of the highest-order bit, or vice versa; otherwise OV is cleared.
- PDF is cleared by a system power-up or executing the “CLR WDT” instruction. PDF is set by executing the “HALT” instruction.
- TO is cleared by a system power-up or executing the “CLR WDT” or “HALT” instruction. TO is set by a WDT time-out.
- CZ is the operational result of different flags for different instructions. Refer to register definitions for more details.
- SC is the result of the “XOR” operation which is performed by the OV flag and the MSB of the current instruction operation result.

In addition, on entering an interrupt sequence or executing a subroutine call, the status register will not be pushed onto the stack automatically. If the contents of the status registers are important and if the subroutine can corrupt the status register, precautions must be taken to correctly save it.

• STATUS Register

Bit	7	6	5	4	3	2	1	0
Name	SC	CZ	TO	PDF	OV	Z	AC	C
R/W	R/W	R/W	R	R	R/W	R/W	R/W	R/W
POR	x	x	0	0	x	x	x	x

“x”: unknown

- Bit 7 **SC**: The result of the “XOR” operation which is performed by the OV flag and the MSB of the instruction operation result
- Bit 6 **CZ**: The operational result of different flags for different instructions
 For SUB/SUBM/LSUB/LSUBM instructions, the CZ flag is equal to the Z flag.
 For SBC/SBCM/LSBC/LSBCM instructions, the CZ flag is the “AND” operation result which is performed by the previous operation CZ flag and current operation zero flag.
 For other instructions, the CZ flag will not be affected.

- Bit 5 **TO:** Watchdog Time-out flag
 0: After power up or executing the “CLR WDT” or “HALT” instruction
 1: A watchdog time-out occurred
- Bit 4 **PDF:** Power down flag
 0: After power up or executing the “CLR WDT” instruction
 1: By executing the “HALT” instruction
- Bit 3 **OV:** Overflow flag
 0: No overflow
 1: An operation results in a carry into the highest-order bit but not a carry out of the highest-order bit or vice versa
- Bit 2 **Z:** Zero flag
 0: The result of an arithmetic or logical operation is not zero
 1: The result of an arithmetic or logical operation is zero
- Bit 1 **AC:** Auxiliary flag
 0: No auxiliary carry
 1: An operation results in a carry out of the low nibbles in addition, or no borrow from the high nibble into the low nibble in subtraction
- Bit 0 **C:** Carry flag
 0: No carry-out
 1: An operation results in a carry during an addition operation or if a borrow does not take place during a subtraction operation
 The “C” flag is also affected by a rotate through carry instruction.

EEPROM Data Memory

These devices contain an area of internal EEPROM Data Memory. EEPROM is by its nature a non-volatile form of re-programmable memory, with data retention even when its power supply is removed. By incorporating this kind of data memory, a whole new host of application possibilities are made available to the designer. The availability of EEPROM storage allows information such as product identification numbers, calibration values, specific user data, system setup data or other product information to be stored directly within the product microcontroller. The process of reading and writing data to the EEPROM memory has been reduced to a very trivial affair.

EEPROM Data Memory Structure

The EEPROM Data Memory capacity is 256×8 or 512×8 bits for this series of devices. Unlike the Program Memory and RAM Data Memory, the EEPROM Data Memory is not directly mapped into memory space and is therefore not directly addressable in the same way as the other types of memory. Read and Write operations to the EEPROM are carried out in single byte operations using an address and a data register for HT67L2540A or two address registers for HT67L2550A in Sector 0 and a single control register in Sector 1.

Device	Capacity
HT67L2540A	256×8
HT67L2550A	512×8

EEPROM Registers

Three or four registers control the overall operation of the internal EEPROM Data Memory. These are the address register, EEA for HT67L2540A or registers, EEAL and EEAH for HT67L2550A, the data register, EED and a single control register, EEC. As the EEA or the EEAL, EEAH and EED registers are located in Sector 0, they can be directly accessed in the same way as any other Special Function Register. The EEC register however, being located in Sector 1, can only be read from or

written to indirectly using the MP1L/MP1H or MP2L/MP2H Memory Pointer pairs and Indirect Addressing Register, IAR1/IAP2. Because the EEC control register is located at address 40H in Sector 1, the MP1L or MP2L Memory Pointer must first be set to the value 40H and the MP1H or MP2H Memory Pointer high byte set to the value, 01H, before any operations on the EEC register are executed.

Register Name	Bit							
	7	6	5	4	3	2	1	0
EEA (HT67L2540A)	EEA7	EEA6	EEA5	EEA4	EEA3	EEA2	EEA1	EEA0
EEAL (HT67L2550A)	EEAL7	EEAL6	EEAL5	EEAL4	EEAL3	EEAL2	EEAL1	EEAL0
EEAH (HT67L2550A)	—	—	—	—	—	—	—	EEAH0
EED	D7	D6	D5	D4	D3	D2	D1	D0
EEC	D7	—	—	—	WREN	WR	RDEN	RD

EEPROM Register List

• **EEA Register – HT67L2540A**

Bit	7	6	5	4	3	2	1	0
Name	EEA7	EEA6	EEA5	EEA4	EEA3	EEA2	EEA1	EEA0
R/W	R/W	R/W	R/W	R/W	R/W	R/W	R/W	R/W
POR	0	0	0	0	0	0	0	0

Bit 7~0 **EEA7~EEA0**: Data EEPROM address bit 7 ~ bit 0

• **EEAL Register – HT67L2550A**

Bit	7	6	5	4	3	2	1	0
Name	EEAL7	EEAL6	EEAL5	EEAL4	EEAL3	EEAL2	EEAL1	EEAL0
R/W	R/W	R/W	R/W	R/W	R/W	R/W	R/W	R/W
POR	0	0	0	0	0	0	0	0

Bit 7~0 **EEAL7~EEAL0**: Data EEPROM low byte address bit 7 ~ bit 0

• **EEAH Register – HT67L2550A**

Bit	7	6	5	4	3	2	1	0
Name	—	—	—	—	—	—	—	EEAH0
R/W	—	—	—	—	—	—	—	R/W
POR	—	—	—	—	—	—	—	0

Bit 7~1 Unimplemented, read as “0”

Bit 0 **EEAH0**: Data EEPROM high byte address bit 0

• **EED Register**

Bit	7	6	5	4	3	2	1	0
Name	D7	D6	D5	D4	D3	D2	D1	D0
R/W	R/W	R/W	R/W	R/W	R/W	R/W	R/W	R/W
POR	0	0	0	0	0	0	0	0

Bit 7~0 **D7~D0**: Data EEPROM data bit 7 ~ bit 0

• **EEC Register**

Bit	7	6	5	4	3	2	1	0
Name	D7	—	—	—	WREN	WR	RDEN	RD
R/W	R/W	—	—	—	R/W	R/W	R/W	R/W
POR	0	—	—	—	0	0	0	0

Bit 7 **D7**: Reserved bit, must be fixed at “0”

Bit 6~4 Unimplemented, read as “0”

Bit 3 **WREN**: Data EEPROM Write Enable
 0: Disable
 1: Enable

This is the Data EEPROM Write Enable Bit which must be set high before Data EEPROM write operations are carried out. Clearing this bit to zero will inhibit Data EEPROM write operations.

Bit 2 **WR**: EEPROM Write Control
 0: Write cycle has finished
 1: Activate a write cycle

This is the Data EEPROM Write Control Bit and when set high by the application program will activate a write cycle. This bit will be automatically reset to zero by hardware after the write cycle has finished. Setting this bit high will have no effect if the WREN has not first been set high.

Bit 1 **RDEN**: Data EEPROM Read Enable
 0: Disable
 1: Enable

This is the Data EEPROM Read Enable Bit which must be set high before Data EEPROM read operations are carried out. Clearing this bit to zero will inhibit Data EEPROM read operations.

Bit 0 **RD**: EEPROM Read Control
 0: Read cycle has finished
 1: Activate a read cycle

This is the Data EEPROM Read Control Bit and when set high by the application program will activate a read cycle. This bit will be automatically reset to zero by hardware after the read cycle has finished. Setting this bit high will have no effect if the RDEN has not first been set high.

Note: 1. The WREN, WR, RDEN and RD cannot be set high at the same time in one instruction. The WR and RD cannot be set high at the same time.

2. Ensure that the f_{SUB} clock is stable before executing the write operation.

3. Ensure that the write operation is totally complete before changing the contents of the EEPROM related registers.

Reading Data from the EEPROM

To read data from the EEPROM, the EEPROM address of the data to be read must first be placed in the EEA register for HT67L2540A or the EEAL and EEAH registers for HT67L2550A. Then the read enable bit, RDEN, in the EEC register must be set high to enable the read function. If the RD bit in the EEC register is now set high, a read cycle will be initiated. Setting the RD bit high will not initiate a read operation if the RDEN bit has not been set. When the read cycle terminates, the RD bit will be automatically cleared to zero, after which the data can be read from the EED register. The data will remain in the EED register until another read or write operation is executed. The application program can poll the RD bit to determine when the data is valid for reading.

Writing Data to the EEPROM

To write data to the EEPROM, the EEPROM address of the data to be written must first be placed in the EEA register for HT67L2540A or the EEAL and EEAH registers for HT67L2550A and the data placed in the EED register. To initiate a write cycle, the write enable bit, WREN, in the EEC register must first be set high to enable the write function. After this, the WR bit in the EEC register must be immediately set high to initiate a write cycle. These two instructions must be executed in two consecutive instruction cycles. The global interrupt bit EMI should also first be cleared before implementing any write operations, and then set again after the write cycle has started. Note that setting the WR bit high will not initiate a write cycle if the WREN bit has not been set. As the EEPROM write cycle is controlled using an internal timer whose operation is asynchronous to microcontroller system clock, a certain time will elapse before the data will have been written into the EEPROM. Detecting when the write cycle has finished can be implemented either by polling the WR bit in the EEC register or by using the EEPROM interrupt. When the write cycle terminates, the WR bit will be automatically cleared to zero by the microcontroller, informing the user that the data has been written to the EEPROM. The application program can therefore poll the WR bit to determine when the write cycle has ended.

Write Protection

Protection against inadvertent write operation is provided in several ways. After the device is powered-on the Write Enable bit in the control register will be cleared preventing any write operations. Also at power-on the Memory Pointer high byte register, MP1H or MP2H, will be reset to zero, which means that Data Memory Sector 0 will be selected. As the EEPROM control register is located in Sector 1, this adds a further measure of protection against spurious write operations. During normal program operation, ensuring that the Write Enable bit in the control register is cleared will safeguard against incorrect write operations.

EEPROM Interrupt

The EEPROM write interrupt is generated when an EEPROM write cycle has ended. The EEPROM interrupt must first be enabled by setting the DEE bit in the relevant interrupt register. However as the EEPROM is contained within a Multi-function Interrupt, the associated multi-function interrupt enable bit must also be set. When an EEPROM write cycle ends, the DEF request flag and its associated multi-function interrupt request flag will both be set high. If the global, EEPROM and multi-function interrupts are enabled and the stack is not full, a jump to the associated Multi-function Interrupt vector will take place. When the interrupt is serviced only the Multi-function interrupt flag will be automatically reset, the EEPROM interrupt flag must be manually reset by the application program. The EMI bit will also automatically cleared to disable other interrupts. More details can be obtained in the Interrupt section.

Programming Considerations

Care must be taken that data is not inadvertently written to the EEPROM. Protection can be enhanced by ensuring that the Write Enable bit is normally cleared to zero when not writing. Also the Memory Pointer high byte register, MP1H or MP2H, could be normally cleared to zero as this would inhibit access to Sector 1 where the EEPROM control register exists. Although certainly not necessary, consideration might be given in the application program to the checking of the validity of new write data by a simple read back process.

When writing data, the WR bit must be set high immediately after the WREN bit has been set high, to ensure the write cycle executes correctly. The global interrupt bit EMI should also be cleared before a write cycle is executed and then set high again after a valid write activation procedure has completed. Note that the device should not enter the IDLE or SLEEP mode until the EEPROM read or write operation is totally complete. Otherwise, the EEPROM read or write operation will fail.

Programming Examples – HT67L2540A**Reading data from the EEPROM – polling method**

```
MOV A, EEPROM_ADRES      ; user defined address
MOV EEA, A
MOV A, 40H                ; setup memory pointer MP1L
MOV MP1L, A              ; MP1L points to EEC register
MOV A, 01H                ; setup memory pointer MP1H
MOV MP1H, A
SET IAR1.1                ; set RDEN bit, enable read operations
SET IAR1.0                ; start Read Cycle - set RD bit
BACK:
SZ IAR1.0                 ; check for read cycle end
JMP BACK
CLR IAR1                   ; disable EEPROM read if no more read operations are required
CLR MP1H
MOV A, EED                 ; move read data to register
MOV READ_DATA, A
```

Note: For each read operation, the address register should be re-specified followed by setting the RD bit high to activate a read cycle even if the target address is consecutive.

Writing Data to the EEPROM – polling method

```
MOV A, EEPROM_ADRES      ; user defined address
MOV EEA, A
MOV A, EEPROM_DATA       ; user defined data
MOV EED, A
MOV A, 40H                ; setup memory pointer MP1L
MOV MP1L, A              ; MP1L points to EEC register
MOV A, 01H                ; setup memory pointer MP1H
MOV MP1H, A
CLR EMI
SET IAR1.3                ; set WREN bit, enable write operations
SET IAR1.2                ; start Write Cycle - set WR bit - executed immediately
                        ; after setting WREN bit

SET EMI
BACK:
SZ IAR1.2                 ; check for write cycle end
JMP BACK
CLR MP1H
```

Oscillators

Various oscillator options offer the user a wide range of functions according to their various application requirements. The flexible features of the oscillator functions ensure that the best optimisation can be achieved in terms of speed and power saving. Oscillator selections and operation are selected through the combination of configuration options and relevant control registers.

Oscillator Overview

In addition to being the source of the main system clock the oscillators also provide clock sources for the Watchdog Timer and Time Base Interrupts. External oscillators requiring some external components as well as fully integrated internal oscillators requiring no external components, are provided to form a wide range of both fast and slow system oscillators. The higher frequency oscillators provide higher performance but carry with it the disadvantage of higher power requirements, while the opposite is of course true for the lower frequency oscillators. With the capability of dynamically switching between fast and slow system clock, the devices have the flexibility to optimize the performance/power ratio, a feature especially important in power sensitive portable applications.

Type	Name	Frequency	Pins
External High Speed Crystal	HXT	1MHz~16MHz	OSC1/OSC2
Internal High Speed RC	HIRC	2/4/8MHz	—
Internal Middle Speed RC	MIRC	64/128/256/512kHz	—
External Low Speed Crystal	LXT	32.768kHz	XT1/XT2
Internal Low Speed RC	LIRC	32.768kHz	—

Oscillator Types

System Clock Configurations

There are several oscillator sources, three high speed oscillators and two low speed oscillators. The high speed oscillator is the internal 2/4/8MHz RC oscillator, HIRC, the internal 64/128/256/512kHz RC oscillator, MIRC, and the external crystal oscillator, HXT. The low speed oscillator is the internal 32.768kHz RC oscillator, LIRC, and the external 32.768kHz crystal oscillator, LXT. Selecting whether the low or high speed oscillator is used as the system oscillator is implemented using the CKS2~CKS0 bits in the SCC register and as the system clock can be dynamically selected.

The actual source clock used for the low speed oscillator is chosen via the FSS bit in the SCC register while for the high speed oscillator the source clock is selected by the FHS bit in the SCC register and the IRC2~IRC0 bits in the IRCC register. The frequency of the slow speed or high speed system clock is determined using the CKS2~CKS0 bits in the SCC register. Note that two oscillator selections must be made namely one high speed and one low speed system oscillators.

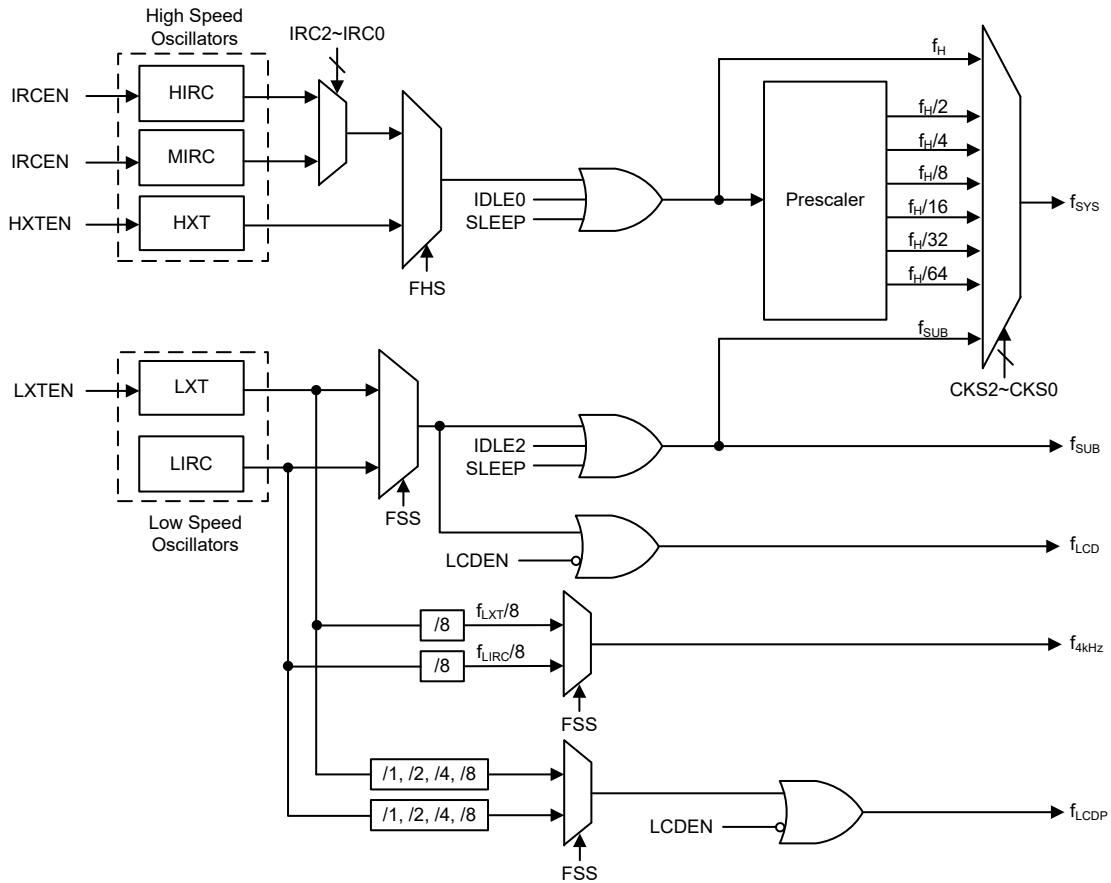

System Clock Configurations

External Crystal/Ceramic Oscillator – HXT

The External Crystal/Ceramic System Oscillator is one of the high frequency oscillator choices, which is selected via a software control bit, FHS. For most crystal oscillator configurations, the simple connection of a crystal across OSC1 and OSC2 will create the necessary phase shift and feedback for oscillation, without requiring external capacitors. However, for some crystal types and frequencies, to ensure oscillation, it may be necessary to add two small value capacitors, C1 and C2. Using a ceramic resonator will usually require two small value capacitors, C1 and C2, to be connected as shown for oscillation to occur. The values of C1 and C2 should be selected in consultation with the crystal or resonator manufacturer's specification.

For oscillator stability and to minimise the effects of noise and crosstalk, it is important to ensure that the crystal and any associated resistors and capacitors along with interconnecting lines are all located as close to the MCU as possible.

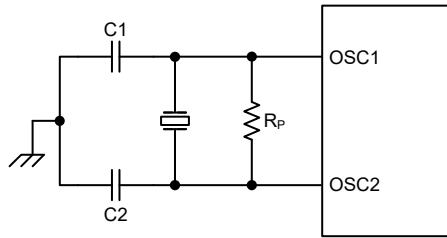

Note: 1. R_p is normally not required. C1 and C2 are required.
 2. Although not shown OSC1/OSC2 pins have a parasitic capacitance of around 7pF.

Crystal/Resonator Oscillator – HXT

HXT Oscillator C1 and C2 Values		
Crystal Frequency	C1	C2
20MHz	0pF	0pF
16MHz	0pF	0pF
12MHz	0pF	0pF
8MHz	0pF	0pF
4MHz	0pF	0pF
1MHz	100pF	100pF

Note: C1 and C2 values are for guidance only.

Crystal Recommended Capacitor Values

Internal High Speed RC Oscillator – HIRC

The high speed internal RC oscillator is one of the high frequency oscillator choices, which is selected by the FHS bit in the SCC register and the IRC2~IRC0 bits in the IRCC register. It is a fully integrated system oscillator requiring no external components. The internal high RC oscillator has three fixed frequencies of 2MHz, 4MHz and 8MHz, which are selected by IRC2~IRC0 bits in the IRCC register. These bits must be setup to match the selected configuration option frequency to ensure that the HIRC frequency accuracy specified in the A.C. Characteristics is achieved. Device trimming during the manufacturing process and the inclusion of internal frequency compensation circuits are used to ensure that the influence of the power supply voltage, temperature and process variations on the oscillation frequency are minimised.

Internal Middle Speed RC Oscillator – MIRC

The middle speed internal RC oscillator is one of the high frequency oscillator choices, which is selected by the FHS bit in the SCC register and the IRC2~IRC0 bits in the IRCC register. It is a fully integrated system oscillator requiring no external components. The internal middle RC oscillator has four fixed frequencies of 64kHz, 128kHz, 256kHz and 512kHz, which are selected by IRC2~IRC0 bits in the IRCC register. These bits must be setup to match the selected configuration option frequency to ensure that the MIRC frequency accuracy specified in the A.C. Characteristics is achieved. Device trimming during the manufacturing process and the inclusion of internal frequency compensation circuits are used to ensure that the influence of the power supply voltage, temperature and process variations on the oscillation frequency are minimised.

Internal 32.768kHz Oscillator – LIRC

The Internal 32.768kHz System Oscillator is one of the low frequency oscillator choices, which is selected via a software control bit, FSS. It is a fully integrated RC oscillator with a typical frequency of 32.768kHz, requiring no external components for its implementation. Device trimming during the manufacturing process and the inclusion of internal frequency compensation circuits are used to ensure that the influence of the power supply voltage, temperature and process variations on the oscillation frequency are minimised.

External 32.768kHz Crystal Oscillator – LXT

The External 32.768kHz Crystal System Oscillator is one of the low frequency oscillator choices, which is selected via a software control bit, FSS. This clock source has a fixed frequency of 32.768kHz and requires a 32.768kHz crystal to be connected between pins XT1 and XT2. The external resistor and capacitor components connected to the 32.768kHz crystal are necessary to provide oscillation. For applications where precise frequencies are essential, these components may be required to provide frequency compensation due to different crystal manufacturing tolerances. After the LXT oscillator is enabled by setting the LXTEN bit to 1, there is a time delay associated with the LXT oscillator waiting for it to start-up.

When the microcontroller enters the SLEEP or IDLE Mode, the system clock is switched off to stop microcontroller activity and to conserve power. However, in many microcontroller applications it may be necessary to keep the internal timers operational even when the microcontroller is in the SLEEP or IDLE Mode. To do this, another clock, independent of the system clock, must be provided.

However, for some crystals, to ensure oscillation and accurate frequency generation, it is necessary to add two small value external capacitors, C1 and C2. The exact values of C1 and C2 should be selected in consultation with the crystal or resonator manufacturer’s specification. The external parallel feedback resistor, R_p, is required.

The pin-shared software control bits determine if the XT1/XT2 pins are used for the LXT oscillator or as I/O or other pin-shared functional pins.

- If the LXT oscillator is not used for any clock source, the XT1/XT2 pins can be used as normal I/O or other pin-shared functional pins.
- If the LXT oscillator is used for any clock source, the 32.768kHz crystal should be connected to the XT1/XT2 pins.

For oscillator stability and to minimise the effects of noise and crosstalk, it is important to ensure that the crystal and any associated resistors and capacitors along with interconnecting lines are all located as close to the MCU as possible.

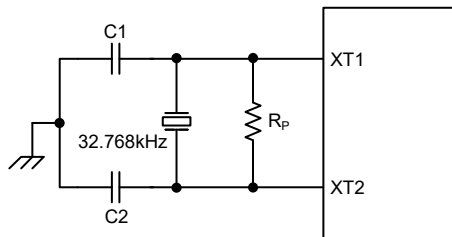

Note: 1. R_p, C1 and C2 are required.
2. Although not shown XT1/XT2 pins have a parasitic capacitance of around 7pF.

External LXT Oscillator

LXT Oscillator C1 and C2 Values		
Crystal Frequency	C1	C2
32.768kHz	10pF	10pF
Note: 1. C1 and C2 values are for guidance only. 2. $R_p=5M\sim 10M\Omega$ is recommended.		

32.768kHz Crystal Recommended Capacitor Values

LXT Oscillator Low Power Function

The LXT oscillator can function in one of two modes, the Speed Up Mode and the Low Power Mode. The mode selection is executed using the LXTSP bit in the register.

LXTSP	LXT Mode
0	Low Power
1	Speed Up

When the LXTSP bit is set to high, the LXT Speed Up Mode will be enabled. In the Speed Up Mode the LXT oscillator will power up and stabilise quickly. However, after the LXT oscillator has fully powered up, it can be placed into the Low Power Mode by clearing the LXTSP bit to zero and the oscillator will continue to run but with reduced current consumption. It is important to note that the LXT operating mode switching must be properly controlled before the LXT oscillator clock is selected as the system clock source. Once the LXT oscillator clock is selected as the system clock source using the CKS2~CKS0 bits and FSS bit in the SCC register, the LXT oscillator operating mode cannot be changed.

It should be noted that, no matter what condition the LXTSP bit is set to, the LXT oscillator will always function normally, the only difference is that it will take more time to start up if it is in the low power mode.

Operating Modes and System Clocks

Present day applications require that their microcontrollers have high performance but often still demand that they consume as little power as possible, conflicting requirements that are especially true in battery powered portable applications. The fast clocks required for high performance will by their nature increase current consumption and of course vice versa, lower speed clocks reduce current consumption. As Holtek has provided these devices with both high and low speed clock sources and the means to switch between them dynamically, the user can optimise the operation of their microcontroller to achieve the best performance/power ratio.

System Clocks

Each device has different clock sources for both the CPU and peripheral function operation. By providing the user with a wide range of clock options using register programming, a clock system can be configured to obtain maximum application performance.

The main system clock, can come from either a high frequency, f_H , or low frequency, f_{SUB} , source, and is selected using the CKS2~CKS0 bits in the SCC register. The high speed system clock can be sourced from either an HXT or HIRC or MIRC oscillator, selected via configuring the FHS bit in the SCC register and the IRC2~IRC0 bits in the IRCC register. The low speed system clock source can be sourced from the internal clock f_{SUB} . If f_{SUB} is selected then it can be sourced by either the LXT or LIRC oscillator, selected via configuring the FSS bit in the SCC register. The other choice, which is a divided version of the high speed system oscillator has a range of $f_H/2\sim f_H/64$.

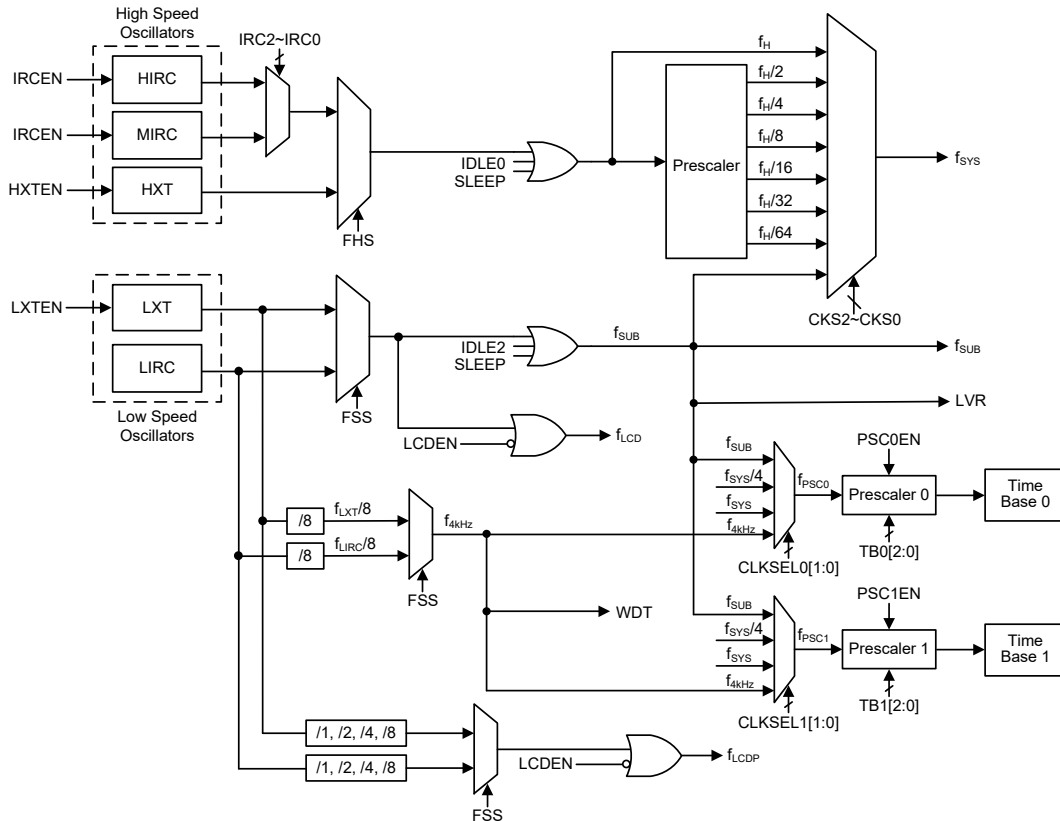

Device Clock Configurations

Note: When the system clock source f_{SYS} is switched to f_{SUB} from f_H , the high speed oscillator will stop to conserve the power or continue to oscillate to provide the clock source, $f_H \sim f_H/64$, for peripheral circuit to use, which is determined by configuring the corresponding high speed oscillator enable control bit.

System Operation Modes

There are six different modes of operation for the microcontroller, each one with its own special characteristics and which can be chosen according to the specific performance and power requirements of the application. There are two modes allowing normal operation of the microcontroller, the FAST Mode and SLOW Mode. The remaining four modes, the SLEEP, IDLE0, IDLE1 and IDLE2 Mode are used when the microcontroller CPU is switched off to conserve power.

Operation Mode	CPU	Register Setting			f_{SYS}	f_H	f_{SUB}	f_{4kHz}	f_{LCD}/f_{LCDP}
		FHIDEN	FSIDEN	CKS2~CKS0					
FAST	On	x	x	000~110	$f_H \sim f_H/64$	On	On ⁽²⁾	On/Off ⁽²⁾	On/Off ⁽³⁾
SLOW	On	x	x	111	f_{SUB}	On/Off ⁽¹⁾	On ⁽²⁾	On/Off ⁽²⁾	On/Off ⁽³⁾
IDLE0	Off	0	1	000~110	Off	Off	On ⁽²⁾	On/Off ⁽²⁾	On/Off ⁽³⁾
				111	On				
IDLE1	Off	1	1	xxx	On	On	On ⁽²⁾	On/Off ⁽²⁾	On/Off ⁽³⁾
IDLE2	Off	1	0	000~110	On	On	Off ⁽²⁾	On/Off ⁽²⁾	On/Off ⁽³⁾
				111	Off				
SLEEP	Off	0	0	xxx	Off	Off	Off ⁽²⁾	On/Off ⁽²⁾	On/Off ⁽³⁾

"x": Don't care

Note: 1. The f_H clock will be switched on or off by configuring the corresponding oscillator enable bit in the SLOW mode.

2. The f_{SUB} and f_{4kHz} clocks are from the LXT or LIRC oscillator, selected via configuring the FSS bit.
 - a. If the LXT is disabled by clearing the LXTEN bit, when the FSS bit is set to 0, the f_{SUB} and f_{4kHz} clock are from the LIRC oscillator.
 - b. If the LXT is disabled by clearing the LXTEN bit, when the FSS bit is set to 1, the f_{SUB} and f_{4kHz} clock are from the LIRC oscillator.
 - c. If the LXT is enabled by setting the LXTEN bit, when the FSS bit is set to 0, the f_{SUB} and f_{4kHz} clock are from the LIRC oscillator.
 - d. If the LXT is enabled by setting the LXTEN bit and the LXTF bit is equal to 1, the FSS bit can be set to 1 by the software, the f_{SUB} and f_{4kHz} clock will come from the LXT oscillator and the LIRC oscillator will be turned off automatically.
 - e. The f_{SUB} and f_{4kHz} clock source oscillator and LXT/LIRC oscillator on/off status table as shown:

LXTEN	LXTF	FSS	f_{SUB} and f_{4kHz}	LIRC	LXT
0	0	0	LIRC	On	Off
0	0	1	LIRC	On	Off
1	x	0	LIRC	On	On
1	1	1	LXT	Off	On

The LXT can be switched on or off by the LXTEN bit in the LXTC register. When the LXTEN bit is set high, the LXT will be turned on and provides clock source for f_{SUB} and f_{4kHz} which are used for the Time Base and WDT functions.

In the SLEEP/IDLE2 mode, if the FSS bit is 0, the LIRC will be turned on when the Time Base, WDT or LCD is on; the LIRC will be turned off when the Time Base and WDT and LCD are off. The LXT can be switched on/off only by the LXTEN bit in the LXTC register whatever the FSS bit is.

3. The f_{LCD} and f_{LCDP} clocks are used for the LCD circuit and LCD pump circuit, which are from the LXT or LIRC oscillator, selected via configuring the FSS bit and LCDEN bit in the LCDC0 register. The f_{LCD} and f_{LCDP} clock source oscillator and LXT/LIRC oscillator on/off status table as shown:

LXTEN	LXTF	FSS	LCDEN	f_{LCD} and f_{LCDP}	LIRC	LXT
x	x	x	0	Off	x	x
0	0	0	1	LIRC	On	Off
0	0	1	1	LIRC	On	Off
1	x	0	1	LIRC	On	On
1	1	1	1	LXT	Off	On

FAST Mode

This is one of the main operating modes where the microcontroller has all of its functions operational and where the system clock is provided by the high speed oscillator. This mode operates allowing the microcontroller to operate normally with a clock source which will come from one of the high speed oscillators, either the HXT or HIRC or MIRC oscillator, selected via configuring the FHS bit in the SCC register and the IRC2~IRC0 bits in the IRCC register. The high speed oscillator will however first be divided by a ratio ranging from 1 to 64, the actual ratio being selected by the CKS2~CKS0 bits in the SCC register. Although a high speed oscillator is used, running the microcontroller at a divided clock ratio reduces the operating current.

SLOW Mode

This is also a mode where the microcontroller operates normally although now with a slower speed clock source. The clock source used will be from f_{SUB} , which is derived from the LXT or LIRC oscillator, selected via configuring the FSS bit in the SCC register.

SLEEP Mode

The SLEEP Mode is entered when a HALT instruction is executed and when the FHIDEN and FSIDEN bits are low. In the SLEEP mode the CPU will be stopped. The f_{SUB} clock provided to the

peripheral function will also be stopped, too. However, the f_{4kHz} clock can continue to operate if the Time Base or WDT function is enabled. The LIRC/LXT will be turned on and divided by 8 to provide the clock source for the Time Base and WDT functions.

IDLE0 Mode

The IDLE0 Mode is entered when a HALT instruction is executed and when the FHIDEN bit in the SCC register is low and the FSIDEN bit in the SCC register is high. In the IDLE0 Mode the CPU will be switched off but the low speed oscillator will be turned on to drive some peripheral functions.

IDLE1 Mode

The IDLE1 Mode is entered when a HALT instruction is executed and when the FHIDEN and the FSIDEN bits in the SCC register are high. In the IDLE1 Mode the CPU will be switched off but both the high and low speed oscillators will be turned on to provide a clock source to keep some peripheral functions operational.

IDLE2 Mode

The IDLE2 Mode is entered when a HALT instruction is executed and when the FHIDEN bit in the SCC register is high and the FSIDEN bit in the SCC register is low. In the IDLE2 Mode the CPU will be switched off but the high speed oscillator will be turned on to provide a clock source to keep some peripheral functions operational.

Control Registers

The registers, SCC, IRCC, HXTC and LXTC, are used to control the system clock and the corresponding oscillator configurations.

Register Name	Bit							
	7	6	5	4	3	2	1	0
SCC	CKS2	CKS1	CKS0	—	FHS	FSS	FHIDEN	FSIDEN
IRCC	—	—	—	IRC2	IRC1	IRC0	IRCF	IRCEN
HXTC	—	—	—	—	—	HXTM	HXTF	HXTEN
LXTC	—	—	—	—	—	LXTSP	LXTF	LXTEN

System Operating Mode Control Register List

• SCC Register

Bit	7	6	5	4	3	2	1	0
Name	CKS2	CKS1	CKS0	—	FHS	FSS	FHIDEN	FSIDEN
R/W	R/W	R/W	R/W	—	R/W	R/W	R/W	R/W
POR	1	1	1	—	0	0	0	0

Bit 7~5 **CKS2~CKS0:** System clock selection

000: f_H
 001: $f_H/2$
 010: $f_H/4$
 011: $f_H/8$
 100: $f_H/16$
 101: $f_H/32$
 110: $f_H/64$
 111: f_{SUB}

These three bits are used to select which clock is used as the system clock source. In addition to the system clock source directly derived from f_H or f_{SUB} , a divided version of the high speed system oscillator can also be chosen as the system clock source.

Bit 4 Unimplemented, read as “0”

- Bit 3 **FHS**: High Frequency oscillator selection
 0: HIRC or MIRC
 1: HXT
 The HIRC and MIRC are two group frequencies which can be selected by the IRC2~IRC0 bits in the IRCC register. When the IRC2 bit is cleared to 0, the HIRC frequency group will be selected. When the IRC2 bit is set to 1, the MIRC frequency group will be selected.
- Bit 2 **FSS**: Low Frequency oscillator selection
 0: LIRC
 1: LXT
- Bit 1 **FHIDEN**: High Frequency oscillator control when CPU is switched off
 0: Disable
 1: Enable
 This bit is used to control whether the high speed oscillator is activated or stopped when the CPU is switched off by executing a “HALT” instruction.
- Bit 0 **FSIDEN**: Low Frequency oscillator control when CPU is switched off
 0: Disable
 1: Enable
 This bit is used to control whether the low speed oscillator is activated or stopped when the CPU is switched off by executing a “HALT” instruction.

Note: A certain delay is required before the relevant clock is successfully switched to the target clock source after any clock switching setup using the CKS2~CKS0 bits, FHS bit or FSS bit. A proper delay time must be arranged before executing the following operations which require immediate reaction with the target clock source.

Clock switching delay time = $4 \times t_{SYS} + [0 \sim (1.5 \times t_{curr.} + 0.5 \times t_{Tar.})]$, where $t_{curr.}$ indicates the current clock period, $t_{Tar.}$ indicates the target clock period and t_{SYS} indicates the current system clock period.

• **IRCC Register**

Bit	7	6	5	4	3	2	1	0
Name	—	—	—	IRC2	IRC1	IRC0	IRCF	IRCCEN
R/W	—	—	—	R/W	R/W	R/W	R	R/W
POR	—	—	—	0	0	0	0	0

- Bit 7~5 Unimplemented, read as “0”
- Bit 4~2 **IRC2~IRC0**: HIRC or MIRC frequency selection
 000: 2MHz
 001: 4MHz
 010: 8MHz
 011: 2MHz
 100: 64kHz
 101: 128kHz
 110: 256kHz
 111: 512kHz
 When the HIRC or MIRC oscillator is enabled or the HIRC or MIRC frequency selection is changed by application program, the clock frequency will automatically be changed after the IRCF flag is set high.
 It is recommended that the HIRC or MIRC frequency selected by these three bits should be the same with the frequency determined by the configuration option to achieve the HIRC/MIRC frequency accuracy specified in the A.C. Characteristics.
- Bit 1 **IRCF**: HIRC or MIRC oscillator stable flag
 0: Unstable
 1: Stable

This bit is used to indicate whether the HIRC or MIRC oscillator is stable or not. When the IRCEN bit is set high to enable the HIRC or MIRC oscillator, the IRCF bit will first be cleared to 0 and then set high after the HIRC or MIRC oscillator is stable.

Bit 0 **IRCEN**: HIRC or MIRC oscillator enable control
 0: Disable
 1: Enable

• **HXTC Register**

Bit	7	6	5	4	3	2	1	0
Name	—	—	—	—	—	HXTM	HXTF	HXTEN
R/W	—	—	—	—	—	R/W	R	R/W
POR	—	—	—	—	—	0	0	0

Bit 7~3 Unimplemented, read as “0”

Bit 2 **HXTM**: HXT mode selection
 0: HXT frequency \leq 10MHz (sink/source current is smaller)
 1: HXT frequency $>$ 10MHz (sink/source current is larger)

Note that this bit should be configured correctly according to the used HXT frequency. If HXTM=0 while the HXT frequency is larger than 10MHz, the oscillation performance at a low voltage condition may be not well. If HXTM=1 while the HXT frequency is less than 10MHz, the oscillator frequency and the current may be abnormal.

This bit must be properly configured before the HXT is enabled. When the OSC1 and OSC2 pin functions have been enabled using relevant pin-shared control bits and the HXTEN bit has been set to 1 to enable the HXT oscillator, it is invalid to change the value of the HXTM bit. When the OSC1 or OSC2 pin function is disabled, then the HXTM bit can be changed by software, regardless of the HXTEN bit value.

Bit 1 **HXTF**: HXT oscillator stable flag
 0: Unstable
 1: Stable

This bit is used to indicate whether the HXT oscillator is stable or not. When the HXTEN bit is set to 1 to enable the HXT oscillator, the HXTF bit will first be cleared to 0 and then set to 1 after the HXT oscillator is stable.

Bit 0 **HXTEN**: HXT oscillator enable control
 0: Disable
 1: Enable

• **LXTC Register**

Bit	7	6	5	4	3	2	1	0
Name	—	—	—	—	—	LXTSP	LXTF	LXTEN
R/W	—	—	—	—	—	R/W	R	R/W
POR	—	—	—	—	—	0	0	0

Bit 7~3 Unimplemented, read as “0”

Bit 2 **LXTSP**: LXT speed up control
 0: Disable – Low power
 1: Enable – Speed up

This bit is used to control whether the LXT oscillator is operating in the low power or speed up mode. When the LXTSP bit is set high, the LXT oscillator will oscillate quickly but consume more power. If the LXTSP bit is cleared to zero, the LXT oscillator will consume less power but take longer time to stabilise. It is important to note that this bit cannot be changed after the LXT oscillator is selected as the system clock source using the CKS2~CKS0 and FSS bits in the SCC register.

- Bit 1 **LXTF**: LXT oscillator stable flag
 0: Unstable
 1: Stable
 This bit is used to indicate whether the LXT oscillator is stable or not. When the LXTEN bit is set to 1 to enable the LXT oscillator, the LXTF bit will first be cleared to 0 and then set to 1 after the LXT oscillator is stable.
- Bit 0 **LXTEN**: LXT oscillator enable control
 0: Disable
 1: Enable

Operating Mode Switching

These devices can switch between operating modes dynamically allowing the user to select the best performance/power ratio for the present task in hand. In this way microcontroller operations that do not require high performance can be executed using slower clocks thus requiring less operating current and prolonging battery life in portable applications.

In simple terms, Mode Switching between the FAST Mode and SLOW Mode is executed using the CKS2~CKS0 bits in the SCC register while Mode Switching from the FAST/SLOW Modes to the SLEEP/IDLE Modes is executed via the HALT instruction. When a HALT instruction is executed, whether the device enters the IDLE Mode or the SLEEP Mode is determined by the condition of the FHIDEN and FSIDEN bits in the SCC register.

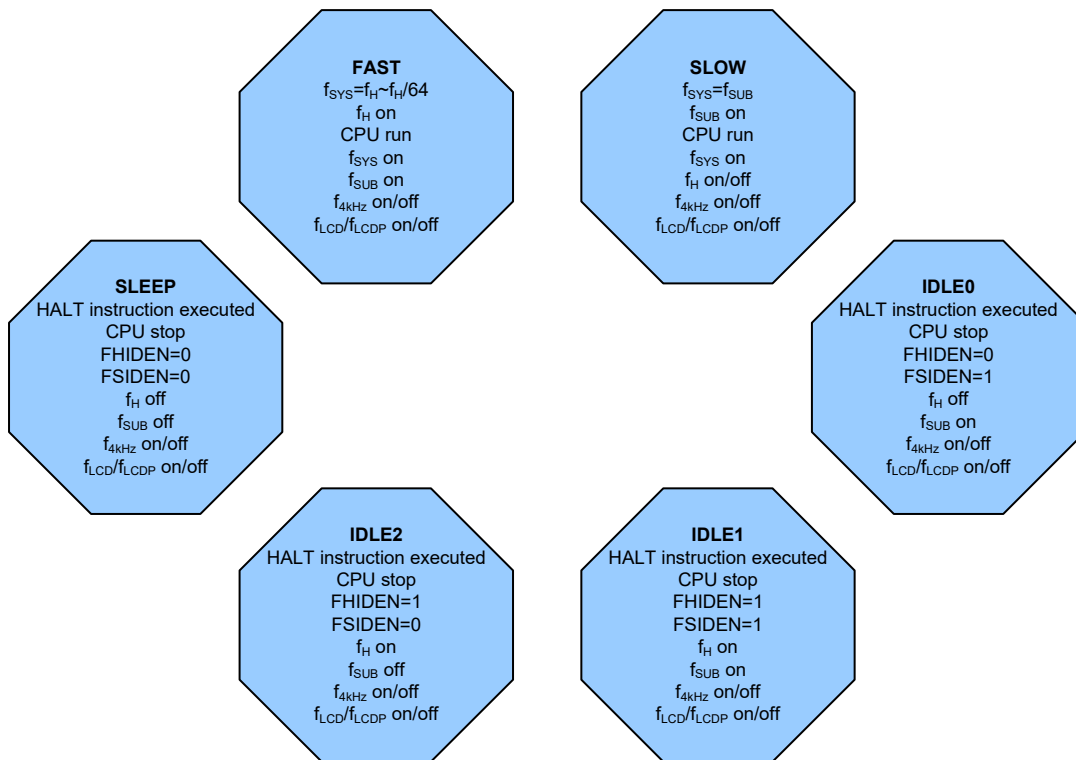

FAST Mode to SLOW Mode Switching

When running in the FAST Mode, which uses the high speed system oscillator, and therefore consumes more power, the system clock can switch to run in the SLOW Mode by setting the CKS2~CKS0 bits to “111” in the SCC register. This will then use the low speed system oscillator which will consume less power. Users may decide to do this for certain operations which do not require high performance and can subsequently reduce power consumption.

The SLOW Mode is sourced from the LXT or LIRC oscillator determined by the FSS bit in the SCC register and therefore requires the selected oscillator to be stable before full mode switching occurs.

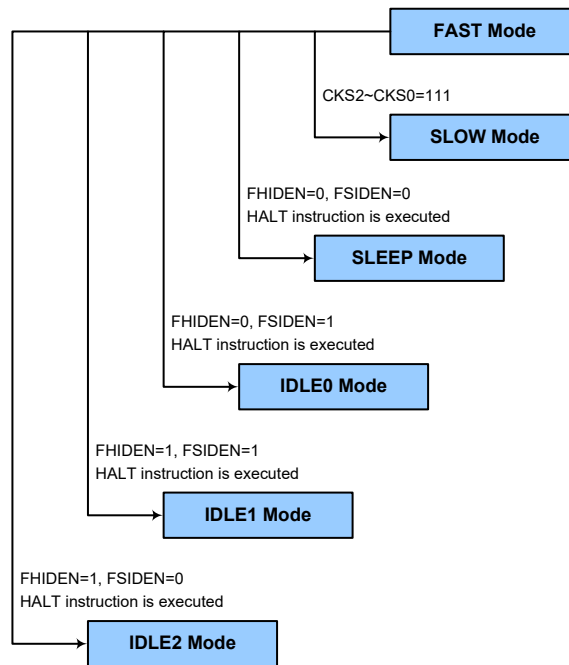

SLOW Mode to FAST Mode Switching

In SLOW mode the system clock is derived from f_{SUB} . When system clock is switched back to the FAST mode from f_{SUB} , the CKS2~CKS0 bits should be set to “000”~“110” and then the system clock will respectively be switched to $f_H \sim f_H/64$.

However, if f_H is not used in the SLOW mode and thus switched off, it will take some time to re-oscillate and stabilise when switching to the FAST mode from the SLOW mode. This is monitored using the HXTF or IRCF bit. The time duration required for the high speed system oscillator stabilization is specified in the System Start Up Time Characteristics.

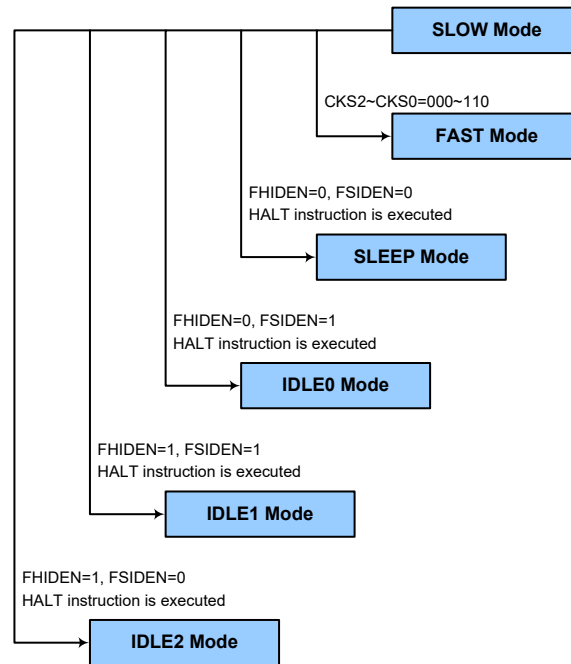

Entering the SLEEP Mode

There is only one way for the device to enter the SLEEP Mode and that is to execute the “HALT” instruction in the application program with both the FHIDEN and FSIDEN bits in the SCC register equal to “0”. In this mode all the clocks and functions will be switched off except the WDT or Time Base or LCD function. When this instruction is executed under the conditions described above, the following will occur:

- The system clock will be stopped and the application program will stop at the “HALT” instruction.
- All the clocks will be stopped except the f_{4kHz} , f_{LCD} and f_{LCDP} clocks which will be on if the WDT or Time Base or LCD function is enabled. The LIRC or LXT oscillator depending on the FSS bit setting will be turned on and provides the clock source.
- The Data Memory contents and registers will maintain their present condition.
- The I/O ports will maintain their present conditions.
- In the status register, the Power Down flag, PDF, will be set and the Watchdog time-out flag, TO, will be cleared.
- The WDT will be cleared and resume counting if the WDT is enabled. If the WDT function is disabled, the WDT will be cleared and then stopped.

Entering the IDLE0 Mode

There is only one way for the device to enter the IDLE0 Mode and that is to execute the “HALT” instruction in the application program with the FHIDEN bit in the SCC register equal to “0” and the FSIDEN bit in the SCC register equal to “1”. When this instruction is executed under the conditions described above, the following will occur:

- The f_H clock will be stopped and the application program will stop at the “HALT” instruction, but the f_{SUB} clock will be on.
- The f_{4kHz} , f_{LCD} and f_{LCDP} clocks which will be on if the WDT or Time Base or LCD function is enabled. The LIRC or LXT oscillator depending on the FSS bit setting will be turned on and provides the clock source.

- The Data Memory contents and registers will maintain their present condition.
- The I/O ports will maintain their present conditions.
- In the status register, the Power Down flag, PDF, will be set and the Watchdog time-out flag, TO, will be cleared.
- The WDT will be cleared and resume counting if the WDT is enabled. If the WDT function is disabled, the WDT will be cleared and then stopped.

Entering the IDLE1 Mode

There is only one way for the device to enter the IDLE1 Mode and that is to execute the “HALT” instruction in the application program with both the FHIDEN and FSIDEN bits in the SCC register equal to “1”. When this instruction is executed under the conditions described above, the following will occur:

- The f_H and f_{SUB} clocks will be on but the application program will stop at the “HALT” instruction.
- The f_{4kHz} , f_{LCD} and f_{LCDP} clocks which will be on if the WDT or Time Base or LCD function is enabled. The LIRC or LXT oscillator depending on the FSS bit setting will be turned on and provides the clock source.
- The Data Memory contents and registers will maintain their present condition.
- The I/O ports will maintain their present conditions.
- In the status register, the Power Down flag, PDF, will be set and the Watchdog time-out flag, TO, will be cleared.
- The WDT will be cleared and resume counting if the WDT is enabled. If the WDT function is disabled, the WDT will be cleared and then stopped.

Entering the IDLE2 Mode

There is only one way for the device to enter the IDLE2 Mode and that is to execute the “HALT” instruction in the application program with the FHIDEN bit in the SCC register equal to “1” and the FSIDEN bit in the SCC register equal to “0”. When this instruction is executed under the conditions described above, the following will occur:

- The f_H clock will be on but the f_{SUB} clock will be off and the application program will stop at the “HALT” instruction.
- The f_{4kHz} , f_{LCD} and f_{LCDP} clocks which will be on if the WDT or Time Base or LCD function is enabled. The LIRC or LXT oscillator depending on the FSS bit setting will be turned on and provides the clock source.
- The Data Memory contents and registers will maintain their present condition.
- The I/O ports will maintain their present conditions.
- In the status register, the Power Down flag, PDF, will be set and the Watchdog time-out flag, TO, will be cleared.
- The WDT will be cleared and resume counting if the WDT is enabled. If the WDT function is disabled, the WDT will be cleared and then stopped.

Standby Current Considerations

As the main reason for entering the SLEEP or IDLE Mode is to keep the current consumption of the device to as low a value as possible, perhaps only in the order of several micro-amps except in the IDLE1 and IDLE2 Mode, there are other considerations which must also be taken into account by the circuit designer if the power consumption is to be minimised. Special attention must be made to the I/O pins on the device. All high-impedance input pins must be connected to either a fixed high or low level as any floating input pins could create internal oscillations and result in increased current consumption. This also applies to the devices which have different package types, as there may be unbonded pins. These must either be set as outputs or if setup as inputs must have pull-high resistors connected.

Care must also be taken with the loads, which are connected to I/O pins, which are set as outputs. These should be placed in a condition in which minimum current is drawn or connected only to external circuits that do not draw current, such as other CMOS inputs. Also note that additional standby current will also be required if the LXT or LIRC oscillator has enabled.

In the IDLE1 and IDLE2 Mode the high speed oscillator is on, if the peripheral function clock source is derived from the high speed oscillator, the additional standby current will also be perhaps in the order of several hundred micro-amps.

Wake-up

To minimise power consumption the device can enter the SLEEP or any IDLE Mode, where the CPU will be switched off. However, when the device is woken up again, it will take a considerable time for the original system oscillator to restart, stabilise and allow normal operation to resume.

After the system enters the SLEEP or IDLE Mode, it can be woken up from one of various sources listed as follows:

- An external $\overline{\text{RES}}$ pin reset
- An external falling edge on Port A
- A system interrupt
- A WDT overflow

If the system is woken up by an external $\overline{\text{RES}}$ pin reset, the device will experience a full system reset, however, if the device is woken up by a WDT overflow, a Watchdog Timer reset will be initiated. Although both of these wake-up methods will initiate a reset operation, the actual source of the wake-up can be determined by examining the TO and PDF flags. The PDF flag is cleared by a system power-up or executing the clear Watchdog Timer instructions and is set when executing the “HALT” instruction. The TO flag is set if a WDT time-out occurs, and causes a wake-up that only resets the Program Counter and Stack Pointer, the other flags remain in their original status.

Each pin on Port A can be setup using the PAWU register to permit a negative transition on the pin to wake-up the system. When a pin wake-up occurs, the program will resume execution at the instruction following the “HALT” instruction. If the system is woken up by an interrupt, then two possible situations may occur. The first is where the related interrupt is disabled or the interrupt is enabled but the stack is full, in which case the program will resume execution at the instruction following the “HALT” instruction. In this situation, the interrupt which woke up the device will not be immediately serviced, but will rather be serviced later when the related interrupt is finally enabled or when a stack level becomes free. The other situation is where the related interrupt is enabled and the stack is not full, in which case the regular interrupt response takes place. If an interrupt request flag is set high before entering the SLEEP or IDLE Mode, the wake-up function of the related interrupt will be disabled.

Watchdog Timer

The Watchdog Timer is provided to prevent program malfunctions or sequences from jumping to unknown locations, due to certain uncontrollable external events such as electrical noise.

Watchdog Timer Clock Source

The Watchdog Timer clock source is provided by the internal clock, f_{kHz} , which is sourced from the LXT or LIRC oscillator, selected via configuring the FSS bit. The LIRC internal oscillator has an approximate frequency of 32.768kHz and this specified internal clock period can vary with V_{DD} , temperature and process variations. The LXT oscillator is supplied by an external 32.768kHz crystal. The Watchdog Timer source clock is then subdivided by a ratio of 2^8 to 2^{18} to give longer timeouts, the actual value being chosen using the WS2~WS0 bits in the WDTC register.

Watchdog Timer Control Register

A single register, WDTC, controls the required time-out period as well as the Watchdog Timer enable/disable and the MCU reset operation.

• WDTC Register

Bit	7	6	5	4	3	2	1	0
Name	WE4	WE3	WE2	WE1	WE0	WS2	WS1	WS0
R/W	R/W	R/W	R/W	R/W	R/W	R/W	R/W	R/W
POR	0	1	0	1	0	0	1	0

Bit 7~3 **WE4~WE0:** WDT function software control

10101: Disable

01010: Enable

Other values: Reset MCU

When these bits are changed to any other values due to environmental noise the microcontroller will be reset; this reset operation will be activated after a delay time, t_{RESET} , and the WRF bit in the RSTFC register will be set high.

Bit 2~0 **WS2~WS0:** WDT time-out period selection

000: $2^8/f_{kHz}$

001: $2^{10}/f_{kHz}$

010: $2^{12}/f_{kHz}$

011: $2^{14}/f_{kHz}$

100: $2^{15}/f_{kHz}$

101: $2^{16}/f_{kHz}$

110: $2^{17}/f_{kHz}$

111: $2^{18}/f_{kHz}$

These three bits determine the division ratio of the Watchdog Timer source clock, which in turn determines the timeout period.

• RSTFC Register

Bit	7	6	5	4	3	2	1	0
Name	—	—	—	—	RSTF	LVRF	LRF	WRF
R/W	—	—	—	—	R/W	R/W	R/W	R/W
POR	—	—	—	—	0	x	0	0

“x”: unknown

Bit 7~4 Unimplemented, read as “0”

Bit 3 **RSTF:** Reset control register software reset flag

Refer to \overline{RES} Pin Reset section.

Bit 2 **LVRF:** LVR function reset flag

Refer to the Low Voltage Reset section.

- Bit 1 **LRF**: LVR control register software reset flag
Refer to the Low Voltage Reset section.
- Bit 0 **WRF**: WDT control register software reset flag
0: Not occurred
1: Occurred
- This bit is set high by the WDT control register software reset and cleared to zero by the application program. Note that this bit can only be cleared to zero by the application program.

Watchdog Timer Operation

The Watchdog Timer operates by providing a device reset when its timer overflows. This means that in the application program and during normal operation the user has to strategically clear the Watchdog Timer before it overflows to prevent the Watchdog Timer from executing a reset. This is done using the clear watchdog instruction. If the program malfunctions for whatever reason, jumps to an unknown location, or enters an endless loop, the clear instruction will not be executed in the correct manner, in which case the Watchdog Timer will overflow and reset the device. There are five bits, WE4~WE0, in the WDTC register to offer the enable/disable control of the Watchdog Timer and the MCU reset. The WDT function will be disabled when the WE4~WE0 bits are set to a value of 10101B while the WDT function will be enabled if the WE4~WE0 bits are equal to 01010B. If the WE4~WE0 bits are set to any other values, other than 01010B and 10101B, it will reset the device after a delay time, t_{SRESET} . After power-on these bits will have a value of 01010B.

WE4~WE0 Bits	WDT Function
10101B	Disable
01010B	Enable
Any other value	Reset MCU

Watchdog Timer Enable/Disable Control

Under normal program operation, a Watchdog Timer time-out will initialise a device reset and set the status bit TO. However, if the system is in the SLEEP or IDLE Mode, when a Watchdog Timer time-out occurs, the TO bit in the status register will be set and only the Program Counter and Stack Pointer will be reset. Four methods can be adopted to clear the contents of the Watchdog Timer. The first is a WDTC software reset, which means a certain value except 01010B and 10101B written into the WE4~WE0 bits, the second is using the Watchdog Timer software clear instruction, the third is via a HALT instruction. The last is an external hardware reset, which means a low level on the external reset pin if the external reset pin is selected by the RSTC register.

There is only one method of using software instruction to clear the Watchdog Timer. That is to use the single “CLR WDT” instruction to clear the WDT.

The maximum time-out period is when the 2^{18} division ratio is selected. As an example, with a 32.768kHz LIRC oscillator as its source clock, this will give a maximum watchdog period of around 8 seconds for the 2^{18} division ratio, and a minimum timeout of 8ms for the 2^8 division ratio.

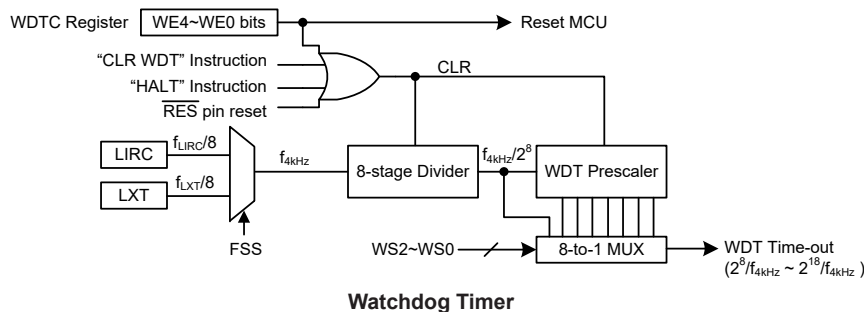

Reset and Initialisation

A reset function is a fundamental part of any microcontroller ensuring that the device can be set to some predetermined condition irrespective of outside parameters. The most important reset condition is after power is first applied to the microcontroller. In this case, internal circuitry will ensure that the microcontroller, after a short delay, will be in a well-defined state and ready to execute the first program instruction. After this power-on reset, certain important internal registers will be set to defined states before the program commences. One of these registers is the Program Counter, which will be reset to zero forcing the microcontroller to begin program execution from the lowest Program Memory address.

In addition to the power-on reset, situations may arise where it is necessary to forcefully apply a reset condition when the microcontroller is already running, the $\overline{\text{RES}}$ line is forcefully pulled low. In such a case, known as a normal operation reset, some of the microcontroller registers remain unchanged allowing the microcontroller to proceed with normal operation after the reset line is allowed to return high.

Another reset exists in the form of a Low Voltage Reset, LVR, where a full reset, similar to the $\overline{\text{RES}}$ reset is implemented in situations where the power supply voltage falls below a certain threshold. Another type of reset is when the Watchdog Timer overflows and resets the microcontroller. All types of reset operations result in different register conditions being setup.

Reset Functions

There are several ways in which a microcontroller reset can occur, through events occurring internally.

Power-on Reset

The most fundamental and unavoidable reset is the one that occurs after power is first applied to the microcontroller. As well as ensuring that the Program Memory begins execution from the first memory address, a power-on reset also ensures that certain other registers are preset to known conditions. All the I/O port and port control registers will power up in a high condition ensuring that all pins will be first set to inputs.

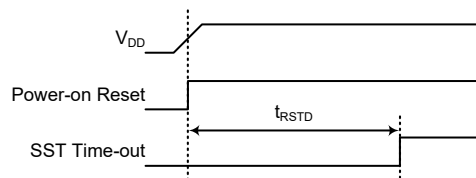

Power-on Reset Timing Chart

$\overline{\text{RES}}$ Pin Reset

As the reset pin is shared with I/O pins, the reset function must be selected using the control register, RSTC. Although the microcontroller has an internal RC reset function, if the V_{DD} power supply rise time is not fast enough or does not stabilise quickly at power-on, the internal reset function may be incapable of providing proper reset operation. For this reason it is recommended that an external RC network is connected to the $\overline{\text{RES}}$ pin, whose additional time delay will ensure that the $\overline{\text{RES}}$ pin remains low for an extended period to allow the power supply to stabilise. During this time delay, normal operation of the microcontroller will be inhibited. After the $\overline{\text{RES}}$ line reaches a certain voltage value, the reset delay time, t_{RSTD} , is invoked to provide an extra delay time after which the microcontroller will begin normal operation. The abbreviation SST in the figures stands for System Start-up Time.

For most applications a resistor connected between VDD and the $\overline{\text{RES}}$ line and a capacitor connected between VSS and the $\overline{\text{RES}}$ pin will provide a suitable external reset circuit. Any wiring connected to the $\overline{\text{RES}}$ pin should be kept as short as possible to minimise any stray noise interference.

For applications that operate within an environment where more noise is present the Enhanced Reset Circuit shown is recommended.

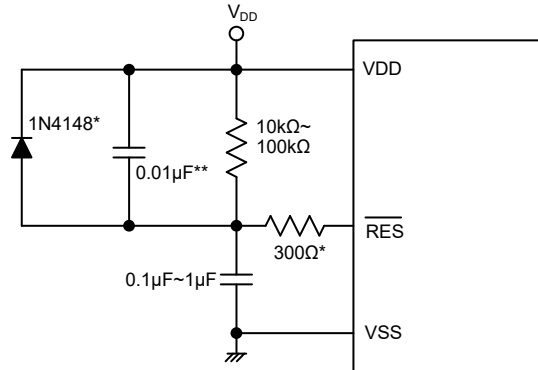

Note: “*” It is recommended that this component is added for added ESD protection.

“**” It is recommended that this component is added in environments where power line noise is significant.

External $\overline{\text{RES}}$ Circuit

Pulling the $\overline{\text{RES}}$ pin low using external hardware will also execute a device reset. In this case, as in the case of other resets, the Program Counter will reset to zero and program execution initiated from this point.

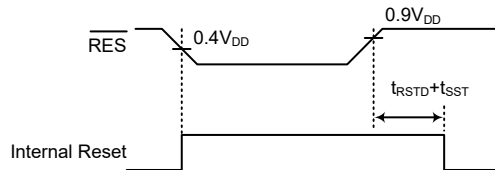

RES Reset Timing Chart

There is an internal reset control register, RSTC, which is used to select the external $\overline{\text{RES}}$ pin function and provide a reset when the device operates abnormally due to the environmental noise interference. If the content of the RSTC register is set to any value other than 01010101B or 10101010B, it will reset the device after a delay time, t_{SRESET} . After power on the register will have a value of 01010101B.

RSTC7~RSTC0 Bits	Reset Function
01010101B	I/O pin or other pin-shared functions
10101010B	$\overline{\text{RES}}$ pin
Any other value	Reset MCU

Internal Reset Function Control

• **RSTC Register**

Bit	7	6	5	4	3	2	1	0
Name	RSTC7	RSTC6	RSTC5	RSTC4	RSTC3	RSTC2	RSTC1	RSTC0
R/W	R/W	R/W	R/W	R/W	R/W	R/W	R/W	R/W
POR	0	1	0	1	0	1	0	1

Bit 7~0 **RSTC7~RSTC0**: Reset function control
 01010101: I/O pin or other pin-shared functions
 10101010: RES pin
 Other values: Reset MCU

If these bits are changed due to adverse environmental conditions, the microcontroller will be reset. The reset operation will be activated after a delay time, t_{SRESET} and the RSTF bit in the RSTFC register will be set to 1.

All resets will reset this register to POR value except the WDT time-out hardware warm reset. Note that if the register is set to 10101010 to set the RES pin, this configuration has higher priority than other related pin-shared controls.

• **RSTFC Register**

Bit	7	6	5	4	3	2	1	0
Name	—	—	—	—	RSTF	LVRF	LRF	WRF
R/W	—	—	—	—	R/W	R/W	R/W	R/W
POR	—	—	—	—	0	x	0	0

“x”: unknown

Bit 7~4 Unimplemented, read as “0”

Bit 3 **RSTF**: Reset control register software reset flag
 0: Not occurred
 1: Occurred

This bit is set to 1 by the RSTC control register software reset and cleared by the application program. This bit can only be cleared to zero by application program.

Bit 2 **LVRF**: LVR function reset flag
 Refer to the Low Voltage Reset section.

Bit 1 **LRF**: LVR control register software reset flag
 Refer to the Low Voltage Reset section.

Bit 0 **WRF**: WDT control register software reset flag
 Refer to the Watchdog Timer Control Register section.

Low Voltage Reset – LVR

The microcontroller contains a low voltage reset circuit in order to monitor the supply voltage of the device and provides an MCU reset should the value fall below a certain predefined level.

The LVR function can be enabled or disabled by the LVRC control register. If the supply voltage of the device drops to within a range of $0.9V \sim V_{LVR}$ such as might occur when changing the battery, the LVR will automatically reset the device internally and the LVRF bit in the RSTFC register will also be set to 1. For a valid LVR signal, a low supply voltage, i.e., a voltage in the range between $0.9V \sim V_{LVR}$ must exist for a time greater than that specified by t_{LVR} in the LVR/LVD Electrical Characteristics. If the low supply voltage state does not exceed this value, the LVR will ignore the low supply voltage and will not perform a reset function. The actual V_{LVR} value can be selected by the LVS7~LVS0 bits in the LVRC register. The actual t_{LVR} value can be selected by the TLVR1~TLVR0 bits in the TLVRC register. If the LVS7~LVS0 bits are changed to some different values by environmental noise, the LVR will reset the device after a delay time, t_{SRESET} . When this happens, the LRF bit in the RSTFC register will be set to 1. After power-on the register will have the value of 01100110B. Note that the LVR function will be automatically disabled when the device enters the SLEEP/IDLE mode.

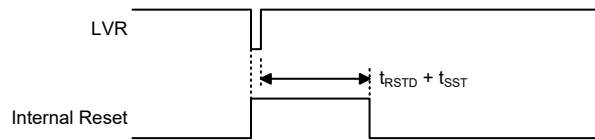

Low Voltage Reset Timing Chart

• **LVRC Register**

Bit	7	6	5	4	3	2	1	0
Name	LVS7	LVS6	LVS5	LVS4	LVS3	LVS2	LVS1	LVS0
R/W	R/W	R/W	R/W	R/W	R/W	R/W	R/W	R/W
POR	0	1	1	0	0	1	1	0

Bit 7~0 **LVS7~LVS0**: LVR Voltage Select control

- 01100110: 1.7V
- 01010101: 1.9V
- 00110011: 2.55V
- 10011001: 3.15V
- 10101010: 3.8V
- 11110000: LVR disable

Any other value: Generates MCU reset – register is reset to POR value

When an actual low voltage condition as specified above occurs, an MCU reset will be generated. The reset operation will be activated after the low voltage condition keeps more than a t_{LVR} time. In this situation the register contents will remain the same after such a reset occurs.

Any register value, other than the six defined register values above, will also result in the generation of an MCU reset. The reset operation will be activated after a delay time, t_{SRESET} . However in this situation the register contents will be reset to the POR value.

• **RSTFC Register**

Bit	7	6	5	4	3	2	1	0
Name	—	—	—	—	RSTF	LVRF	LRF	WRF
R/W	—	—	—	—	R/W	R/W	R/W	R/W
POR	—	—	—	—	0	x	0	0

“x”: unknown

Bit 7~4 Unimplemented, read as “0”

Bit 3 **RSTF**: Reset control register software reset flag
Refer to \overline{RES} Pin Reset section.

Bit 2 **LVRF**: LVR function reset flag
0: Not occurred
1: Occurred

This bit is set high when an actual Low Voltage Reset situation condition occurs. This bit can only be cleared to zero by the application program.

Bit 1 **LRF**: LVR control register software reset flag
0: Not occurred
1: Occurred

This bit is set high by the LVR control register containing any undefined LVR voltage register values. This in effect acts like a software reset function. Note that this bit can only be cleared to zero by the application program.

Bit 0 **WRF**: WDT control register software reset flag
Refer to the Watchdog Timer Control Register section.

• **TLVRC Register**

Bit	7	6	5	4	3	2	1	0
Name	—	—	—	—	—	—	TLVR1	TLVR0
R/W	—	—	—	—	—	—	R/W	R/W
POR	—	—	—	—	—	—	0	1

Bit 7~2 Unimplemented, read as “0”

Bit 1~0 **TLVR1~TLVR0**: Minimum low voltage width to reset time (t_{LVR})
 00: $(7\sim 8) \times t_{SUB}$
 01: $(31\sim 32) \times t_{SUB}$
 10: $(63\sim 64) \times t_{SUB}$
 11: $(127\sim 128) \times t_{SUB}$

IAP Reset

When a specific value of “55H” is written into the FC1 register, a reset signal will be generated to reset the whole device. Refer to the IAP section for more associated details.

Watchdog Time-out Reset during Normal Operation

When the Watchdog time-out Reset during normal operations in the FAST or SLOW mode occurs, the Watchdog time-out flag TO will be set to “1”.

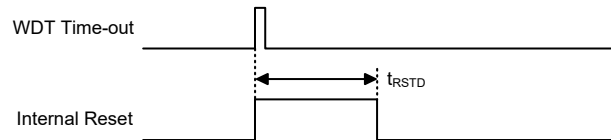

WDT Time-out Reset during Normal Operation Timing Chart

Watchdog Time-out Reset during SLEEP or IDLE Mode

The Watchdog Time-out Reset during SLEEP or IDLE Mode is a little different from other kinds of reset. Most of the conditions remain unchanged except that the Program Counter and the Stack Pointer will be cleared to “0” and the TO will be set to “1”. Refer to the System Start Up Time Characteristics for t_{SST} details.

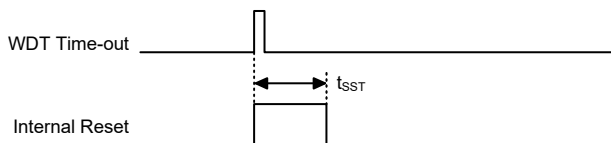

WDT Time-out Reset during SLEEP or IDLE Timing Chart

Reset Initial Conditions

The different types of reset described affect the reset flags in different ways. These flags, known as PDF and TO are located in the status register and are controlled by various microcontroller operations, such as the SLEEP or IDLE Mode function or Watchdog Timer. The reset flags are shown in the table:

TO	PDF	RESET Conditions
0	0	Power-on reset
u	u	LVR reset during FAST or SLOW Mode operation
1	u	WDT time-out reset during FAST or SLOW Mode operation
1	1	WDT time-out reset during IDLE or SLEEP Mode operation

“u”: unchanged

The following table indicates the way in which the various components of the microcontroller are affected after a power-on reset occurs.

Item	Condition after RESET
Program Counter	Reset to zero
Interrupts	All interrupts will be disabled
WDT, Time Bases	Cleared after reset, WDT begins counting
Timer Modules	Timer Module will be turned off
Input/Output Ports	I/O ports will be setup as inputs
Stack Pointer	Stack Pointer will point to the top of the stack

The different kinds of resets all affect the internal registers of the microcontroller in different ways. To ensure reliable continuation of normal program execution after a reset occurs, it is important to know what condition the microcontroller is in after a particular reset occurs. The following table describes how each type of reset affects the microcontroller internal registers. Note that where more than one package type exists the table reflect the situation for the larger package type.

Register	HT67L2540A	HT67L2550A	Power-On Reset	RES Reset (Normal Operation)	RES Reset IDLE/SLEEP)	WDT Time-out (Normal Operation)	WDT Time-out (IDLE/SLEEP)
IAR0	•	•	0000 0000	0000 0000	0000 0000	0000 0000	uuuu uuuu
MP0	•	•	0000 0000	0000 0000	0000 0000	0000 0000	uuuu uuuu
IAR1	•	•	0000 0000	0000 0000	0000 0000	0000 0000	uuuu uuuu
MP1L	•	•	0000 0000	0000 0000	0000 0000	0000 0000	uuuu uuuu
MP1H	•	•	0000 0000	0000 0000	0000 0000	0000 0000	uuuu uuuu
ACC	•	•	xxxx xxxx	uuuu uuuu	uuuu uuuu	uuuu uuuu	uuuu uuuu
PCL	•	•	0000 0000	0000 0000	0000 0000	0000 0000	0000 0000
TBLP	•	•	xxxx xxxx	uuuu uuuu	uuuu uuuu	uuuu uuuu	uuuu uuuu
TBLH	•	•	xxxx xxxx	uuuu uuuu	uuuu uuuu	uuuu uuuu	uuuu uuuu
TBHP	•		---- xxxx	---- uuuu	---- uuuu	---- uuuu	---- uuuu
		•	---x xxxx	---u uuuu	---u uuuu	---u uuuu	---u uuuu
STATUS	•	•	xx00 xxxx	uuuu uuuu	uu01 uuuu	uu1u uuuu	uu11 uuuu
IAR2	•	•	0000 0000	0000 0000	0000 0000	0000 0000	uuuu uuuu
MP2L	•	•	0000 0000	0000 0000	0000 0000	0000 0000	uuuu uuuu
MP2H	•	•	0000 0000	0000 0000	0000 0000	0000 0000	uuuu uuuu
RSTFC	•	•	---- 0x00	---- uuuu	---- uuuu	---- uuuu	---- uuuu
INTC0	•	•	-000 0000	-000 0000	-000 0000	-000 0000	-uuu uuuu
INTC1	•	•	0000 0000	0000 0000	0000 0000	0000 0000	uuuu uuuu
INTC2	•	•	--00 --00	--00 --00	--00 --00	--00 --00	--uu --uu
PA	•	•	1111 1111	1111 1111	1111 1111	1111 1111	uuuu uuuu
PAC	•	•	1111 1111	1111 1111	1111 1111	1111 1111	uuuu uuuu
PAPU	•	•	0000 0000	0000 0000	0000 0000	0000 0000	uuuu uuuu
PAWU	•	•	0000 0000	0000 0000	0000 0000	0000 0000	uuuu uuuu
PB	•	•	1111 1111	1111 1111	1111 1111	1111 1111	uuuu uuuu
PBC	•	•	1111 1111	1111 1111	1111 1111	1111 1111	uuuu uuuu
PBPU	•	•	0000 0000	0000 0000	0000 0000	0000 0000	uuuu uuuu
PC	•		--11 1111	--11 1111	--11 1111	--11 1111	--uu uuuu
		•	1111 1111	1111 1111	1111 1111	1111 1111	uuuu uuuu
PCC	•		--11 1111	--11 1111	--11 1111	--11 1111	--uu uuuu
		•	1111 1111	1111 1111	1111 1111	1111 1111	uuuu uuuu

Register	HT67L2540A	HT67L2550A	Power-On Reset	RES Reset (Normal Operation)	RES Reset IDLE/SLEEP)	WDT Time-out (Normal Operation)	WDT Time-out (IDLE/SLEEP)
PCPU	•		--00 0000	--00 0000	--00 0000	--00 0000	--uu uuuu
		•	0000 0000	0000 0000	0000 0000	0000 0000	uuuu uuuu
PD		•	--11 1111	--11 1111	--11 1111	--11 1111	--uu uuuu
PDC		•	--11 1111	--11 1111	--11 1111	--11 1111	--uu uuuu
PDP		•	--00 0000	--00 0000	--00 0000	--00 0000	--uu uuuu
PMPS	•	•	---- --00	---- --00	---- --00	---- --00	---- --uu
RSTC	•	•	0101 0101	0101 0101	0101 0101	0101 0101	uuuu uuuu
IECC	•	•	0000 0000	0000 0000	0000 0000	0000 0000	uuuu uuuu
LVPUC	•	•	---- ---0	---- ---0	---- ---0	---- ---0	---- ---u
MF10	•	•	--00 --00	--00 --00	--00 --00	--00 --00	--uu --uu
MF11	•		--00 --00	--00 --00	--00 --00	--00 --00	--uu --uu
		•	0000 0000	0000 0000	0000 0000	0000 0000	uuuu uuuu
MF12	•	•	--00 --00	--00 --00	--00 --00	--00 --00	--uu --uu
INETG	•	•	---- 0000	---- 0000	---- 0000	---- 0000	---- uuuu
SCC	•	•	111- 0000	111- 0000	111- 0000	111- 0000	uuu- uuuu
IRCC	•	•	---0 0000	---0 0000	---0 0000	---0 0000	---u uuuu
HXTC	•	•	---- -000	---- -000	---- -000	---- -000	---- -uuu
LXTC	•	•	---- -000	---- -000	---- -000	---- -000	---- -uuu
WDT	•	•	0101 0010	0101 0010	0101 0010	0101 0010	uuuu uuuu
LVRC	•	•	0110 0110	0110 0110	0110 0110	0110 0110	uuuu uuuu
LVDC	•	•	--00 0000	--00 0000	--00 0000	--00 0000	--uu uuuu
EEA	•		0000 0000	0000 0000	0000 0000	0000 0000	uuuu uuuu
EEAL		•	0000 0000	0000 0000	0000 0000	0000 0000	uuuu uuuu
EEAH		•	---- ---0	---- ---0	---- ---0	---- ---0	---- ---u
EED	•	•	0000 0000	0000 0000	0000 0000	0000 0000	uuuu uuuu
STMC0	•	•	0000 0---	0000 0---	0000 0---	0000 0---	uuuu u---
STMC1	•	•	0000 0000	0000 0000	0000 0000	0000 0000	uuuu uuuu
STMDL	•	•	0000 0000	0000 0000	0000 0000	0000 0000	uuuu uuuu
STMDH	•	•	0000 0000	0000 0000	0000 0000	0000 0000	uuuu uuuu
STMAL	•	•	0000 0000	0000 0000	0000 0000	0000 0000	uuuu uuuu
STMAH	•	•	0000 0000	0000 0000	0000 0000	0000 0000	uuuu uuuu
STMRP	•	•	0000 0000	0000 0000	0000 0000	0000 0000	uuuu uuuu
SADC0	•	•	0000 0000	0000 0000	0000 0000	0000 0000	uuuu uuuu
SADC1	•	•	0000 0000	0000 0000	0000 0000	0000 0000	uuuu uuuu
SADC2	•	•	000- --10	000- --10	000- --10	000- --10	uuu- --uu
SADOL	•	•	xx-- ----	xx-- ----	xx-- ----	xx-- ----	uu-- ---- (SABMS=1, ADRF=0)
							uuuu uuuu (SABMS=1, ADRF=1)
			xxxx ----	xxxx ----	xxxx ----	xxxx ----	uuuu ---- (SABMS=0, ADRF=0)
							uuuu uuuu (SABMS=0, ADRF=1)

Register	HT67L2540A	HT67L2550A	Power-On Reset	RES Reset (Normal Operation)	RES Reset IDLE/SLEEP)	WDT Time-out (Normal Operation)	WDT Time-out (IDLE/SLEEP)
SADOH	•	•	xxxx xxxx	xxxx xxxx	xxxx xxxx	xxxx xxxx	uuuu uuuu (SABMS=1, ADRFS=0)
							---- --uu (SABMS=1, ADRFS=1)
			xxxx xxxx	xxxx xxxx	xxxx xxxx	xxxx xxxx	uuuu uuuu (SABMS=0, ADRFS=0)
							---- uuuu (SABMS=0, ADRFS=1)
PSC0R	•	•	---- -000	---- -000	---- -000	---- -000	---- -uuu
TB0C	•	•	0--- -000	0--- -000	0--- -000	0--- -000	u--- -uuu
TB1C	•	•	0--- -000	0--- -000	0--- -000	0--- -000	u--- -uuu
PSC1R	•	•	---- -000	---- -000	---- -000	---- -000	---- -uuu
PCRL	•	•	0000 0000	0000 0000	0000 0000	0000 0000	uuuu uuuu
PCRH	•		---- 0000	---- 0000	---- 0000	---- 0000	---- uuuu
		•	---0 0000	---0 0000	---0 0000	---0 0000	---u uuuu
STKPTR	•	•	0--- -000	0--- -000	0--- -000	0--- -000	u--- -000
CRCCR	•	•	---- ---0	---- ---0	---- ---0	---- ---0	---- ---u
CRCIN	•	•	0000 0000	0000 0000	0000 0000	0000 0000	uuuu uuuu
CRCDL	•	•	0000 0000	0000 0000	0000 0000	0000 0000	uuuu uuuu
CRCDH	•	•	0000 0000	0000 0000	0000 0000	0000 0000	uuuu uuuu
SIMC0	•	•	1110 0000	1110 0000	1110 0000	1110 0000	uuuu uuuu
SIMC1* (UMD=0)	•	•	1000 0001	1000 0001	1000 0001	1000 0001	uuuu uuuu
UUCR1* (UMD=1)	•	•	0000 00x0	0000 00x0	0000 00x0	0000 00x0	uuuu uuuu
SIMD/UTXR_RXR	•	•	xxxx xxxx	xxxx xxxx	xxxx xxxx	xxxx xxxx	uuuu uuuu
SIMA/SIMC2/UUCR2	•	•	0000 0000	0000 0000	0000 0000	0000 0000	uuuu uuuu
UUCR3	•	•	---- ---0	---- ---0	---- ---0	---- ---0	---- ---u
SIMTOC* (UMD=0)	•	•	0000 0000	0000 0000	0000 0000	0000 0000	uuuu uuuu
UBRG* (UMD=1)	•	•	xxxx xxxx	xxxx xxxx	xxxx xxxx	xxxx xxxx	uuuu uuuu
UUSR	•	•	0000 1011	0000 1011	0000 1011	0000 1011	uuuu uuuu
FARL	•	•	0000 0000	0000 0000	0000 0000	0000 0000	uuuu uuuu
FARH	•		---- 0000	---- 0000	---- 0000	---- 0000	---- uuuu
		•	---0 0000	---0 0000	---0 0000	---0 0000	---u uuuu
FD0L	•	•	0000 0000	0000 0000	0000 0000	0000 0000	uuuu uuuu
FD0H	•	•	0000 0000	0000 0000	0000 0000	0000 0000	uuuu uuuu
FD1L	•	•	0000 0000	0000 0000	0000 0000	0000 0000	uuuu uuuu
FD1H	•	•	0000 0000	0000 0000	0000 0000	0000 0000	uuuu uuuu
FD2L	•	•	0000 0000	0000 0000	0000 0000	0000 0000	uuuu uuuu
FD2H	•	•	0000 0000	0000 0000	0000 0000	0000 0000	uuuu uuuu
FD3L	•	•	0000 0000	0000 0000	0000 0000	0000 0000	uuuu uuuu
FD3H	•	•	0000 0000	0000 0000	0000 0000	0000 0000	uuuu uuuu
ORMC	•	•	0000 0000	0000 0000	0000 0000	0000 0000	0000 0000
PTM0C0	•	•	0000 0---	0000 0---	0000 0---	0000 0---	uuuu u---
PTM0C1	•	•	0000 0000	0000 0000	0000 0000	0000 0000	uuuu uuuu
PTM0DL	•	•	0000 0000	0000 0000	0000 0000	0000 0000	uuuu uuuu

Register	HT67L2540A	HT67L2550A	Power-On Reset	RES Reset (Normal Operation)	RES Reset IDLE/SLEEP)	WDT Time-out (Normal Operation)	WDT Time-out (IDLE/SLEEP)
PTM0DH	•	•	0000 0000	0000 0000	0000 0000	0000 0000	uuuu uuuu
PTM0AL	•	•	0000 0000	0000 0000	0000 0000	0000 0000	uuuu uuuu
PTM0AH	•	•	0000 0000	0000 0000	0000 0000	0000 0000	uuuu uuuu
PTM0RPL	•	•	0000 0000	0000 0000	0000 0000	0000 0000	uuuu uuuu
PTM0RPH	•	•	0000 0000	0000 0000	0000 0000	0000 0000	uuuu uuuu
PTM1C0		•	0000 0---	0000 0---	0000 0---	0000 0---	uuuu u---
PTM1C1		•	0000 0000	0000 0000	0000 0000	0000 0000	uuuu uuuu
PTM1DL		•	0000 0000	0000 0000	0000 0000	0000 0000	uuuu uuuu
PTM1DH		•	0000 0000	0000 0000	0000 0000	0000 0000	uuuu uuuu
PTM1AL		•	0000 0000	0000 0000	0000 0000	0000 0000	uuuu uuuu
PTM1AH		•	0000 0000	0000 0000	0000 0000	0000 0000	uuuu uuuu
PTM1RPL		•	0000 0000	0000 0000	0000 0000	0000 0000	uuuu uuuu
PTM1RPH		•	0000 0000	0000 0000	0000 0000	0000 0000	uuuu uuuu
TLVRC	•	•	---- --01	---- --01	---- --01	---- --01	---- --uu
EEC	•	•	0--- 0000	0--- 0000	0--- 0000	0--- 0000	u--- uuuu
FC0	•	•	0000 0000	0000 0000	0000 0000	0000 0000	uuuu uuuu
FC1	•	•	0000 0000	0000 0000	0000 0000	0000 0000	uuuu uuuu
FC2	•	•	---- ---0	---- ---0	---- ---0	---- ---0	---- ---u
IFS0	•		--0- ---0	--0- ---0	--0- ---0	--0- ---0	--u- ---u
		•	-00- ---0	-00- ---0	-00- ---0	-00- ---0	-uu- ---u
IFS1	•	•	---- ---0	---- ---0	---- ---0	---- ---0	---- ---u
IFS2	•	•	---- --00	---- --00	---- --00	---- --00	---- --uu
PAS0	•	•	0000 0000	0000 0000	0000 0000	0000 0000	uuuu uuuu
PAS1	•	•	0000 0000	0000 0000	0000 0000	0000 0000	uuuu uuuu
PBS0	•	•	0000 0000	0000 0000	0000 0000	0000 0000	uuuu uuuu
PBS1	•	•	0000 0000	0000 0000	0000 0000	0000 0000	uuuu uuuu
PCS0	•	•	0000 0000	0000 0000	0000 0000	0000 0000	uuuu uuuu
PCS1	•	•	---- 0000	---- 0000	---- 0000	---- 0000	---- uuuu
PDS0		•	0000 ----	0000 ----	0000 ----	0000 ----	uuuu ----
LCDC0	•	•	0000 0000	0000 0000	0000 0000	0000 0000	uuuu uuuu
LCDC1	•	•	000- 0000	000- 0000	000- 0000	000- 0000	uuu- uuuu
LCDC2	•	•	---- -000	---- -000	---- -000	---- -000	---- -uuu

Note: “u” stands for unchanged

“x” stands for unknown

“-” stands for unimplemented

“*”: The UUCR1 and SIMC1 registers share the same memory address while the UBRG and SIMTOC registers share the same memory address. The default value of the UUCR1 or UBRG register can be obtained when the UMD bit is set high by application program after a reset.

Input/Output Ports

Holtek microcontrollers offer considerable flexibility on their I/O ports. With the input or output designation of every pin fully under user program control, pull-high selections for all ports and wake-up selections on certain pins, the user is provided with an I/O structure to meet the needs of a wide range of application possibilities.

These devices provide bidirectional input/output lines labeled with port names PA~PD. These I/O ports are mapped to the RAM Data Memory with specific addresses as shown in the Special Purpose Data Memory table. All of these I/O ports can be used for input and output operations. For input operation, these ports are non-latching, which means the inputs must be ready at the T2 rising edge of instruction “MOV A, [m]”, where m denotes the port address. For output operation, all the data is latched and remains unchanged until the output latch is rewritten.

Register Name	Bit							
	7	6	5	4	3	2	1	0
PA	PA7	PA6	PA5	PA4	PA3	PA2	PA1	PA0
PAC	PAC7	PAC6	PAC5	PAC4	PAC3	PAC2	PAC1	PAC0
PAPU	PAPU7	PAPU6	PAPU5	PAPU4	PAPU3	PAPU2	PAPU1	PAPU0
PAWU	PAWU7	PAWU6	PAWU5	PAWU4	PAWU3	PAWU2	PAWU1	PAWU0
PB	PB7	PB6	PB5	PB4	PB3	PB2	PB1	PB0
PBC	PBC7	PBC6	PBC5	PBC4	PBC3	PBC2	PBC1	PBC0
PBPU	PBPU7	PBPU6	PBPU5	PBPU4	PBPU3	PBPU2	PBPU1	PBPU0
PC	—	—	PC5	PC4	PC3	PC2	PC1	PC0
PCC	—	—	PCC5	PCC4	PCC3	PCC2	PCC1	PCC0
PCPU	—	—	PCPU5	PCPU4	PCPU3	PCPU2	PCPU1	PCPU0
LVPU	—	—	—	—	—	—	—	LVPU

“—”: Unimplemented, read as “0”

I/O Logic Function Register List – HT67L2540A

Register Name	Bit							
	7	6	5	4	3	2	1	0
PA	PA7	PA6	PA5	PA4	PA3	PA2	PA1	PA0
PAC	PAC7	PAC6	PAC5	PAC4	PAC3	PAC2	PAC1	PAC0
PAPU	PAPU7	PAPU6	PAPU5	PAPU4	PAPU3	PAPU2	PAPU1	PAPU0
PAWU	PAWU7	PAWU6	PAWU5	PAWU4	PAWU3	PAWU2	PAWU1	PAWU0
PB	PB7	PB6	PB5	PB4	PB3	PB2	PB1	PB0
PBC	PBC7	PBC6	PBC5	PBC4	PBC3	PBC2	PBC1	PBC0
PBPU	PBPU7	PBPU6	PBPU5	PBPU4	PBPU3	PBPU2	PBPU1	PBPU0
PC	PC7	PC6	PC5	PC4	PC3	PC2	PC1	PC0
PCC	PCC7	PCC6	PCC5	PCC4	PCC3	PCC2	PCC1	PCC0
PCPU	PCPU7	PCPU6	PCPU5	PCPU4	PCPU3	PCPU2	PCPU1	PCPU0
PD	—	—	PD5	PD4	PD3	PD2	PD1	PD0
PDC	—	—	PDC5	PDC4	PDC3	PDC2	PDC1	PDC0
PDP	—	—	PDP5	PDP4	PDP3	PDP2	PDP1	PDP0
LVPU	—	—	—	—	—	—	—	LVPU

“—”: Unimplemented, read as “0”

I/O Logic Function Register List – HT67L2550A

Pull-high Resistors

Many product applications require pull-high resistors for their switch inputs usually requiring the use of an external resistor. To eliminate the need for these external resistors, all I/O pins, when configured as a digital input have the capability of being connected to an internal pull-high resistor. These pull-high resistors are selected using registers, namely PAPU~PDPU, and are implemented using weak PMOS transistors.

Note that the pull-high resistor can be controlled by the relevant pull-high control register only when the pin-shared functional pin is selected as a digital input or NMOS output. Otherwise, the pull-high resistors cannot be enabled.

• P_xPU Register

Bit	7	6	5	4	3	2	1	0
Name	PxPU7	PxPU6	PxPU5	PxPU4	PxPU3	PxPU2	PxPU1	PxPU0
R/W	R/W	R/W	R/W	R/W	R/W	R/W	R/W	R/W
POR	0	0	0	0	0	0	0	0

P_xPU_n: I/O Port x Pin pull-high function control

0: Disable
1: Enable

The P_xPU_n bit is used to control the pin pull-high function. Here the “x” is the Port name which can be A, B, C or D. However, the actual available bits for each I/O Port may be different.

• LVPUC Register

Bit	7	6	5	4	3	2	1	0
Name	—	—	—	—	—	—	—	LVPU
R/W	—	—	—	—	—	—	—	R/W
POR	—	—	—	—	—	—	—	0

Bit 7~1 Unimplemented, read as “0”

Bit 0 **LVPU**: Pull-high resistor selection for low voltage power supply

0: All pin pull-high resistors are 60kΩ @ 3V
1: All pin pull-high resistors are 15kΩ @ 3V

The LVPUC register is used to select the pull-high resistor value for low voltage power supply applications. Note that the LVPU bit is only available when the corresponding pin pull-high function is enabled. This bit will have no effect on selecting the pull-high resistor value when the pull-high function is disabled.

Port A Wake-up

The HALT instruction forces the microcontroller into the SLEEP or IDLE Mode which preserves power, a feature that is important for battery and other low-power applications. Various methods exist to wake up the microcontroller, one of which is to change the logic condition on one of the Port A pins from high to low. This function is especially suitable for applications that can be woken up via external switches. Each pin on Port A can be selected individually to have this wake-up feature using the PAWU register.

Note that the wake-up function can be controlled by the wake-up control register only when the pin is selected as a general purpose input and the MCU enters the IDLE or SLEEP mode.

• **PAWU Register**

Bit	7	6	5	4	3	2	1	0
Name	PAWU7	PAWU6	PAWU5	PAWU4	PAWU3	PAWU2	PAWU1	PAWU0
R/W	R/W	R/W	R/W	R/W	R/W	R/W	R/W	R/W
POR	0	0	0	0	0	0	0	0

Bit 7~0 **PAWU7~PAWU0**: PA7~PA0 wake-up function control
 0: Disable
 1: Enable

I/O Port Control Registers

Each I/O port has its own control register known as PAC~PDC, to control the input/output configuration. With this control register, each CMOS output or input can be reconfigured dynamically under software control. Each pin of the I/O ports is directly mapped to a bit in its associated port control register. For the I/O pin to function as an input, the corresponding bit of the control register must be written as a “1”. This will then allow the logic state of the input pin to be directly read by instructions. When the corresponding bit of the control register is written as a “0”, the I/O pin will be setup as a CMOS output. If the pin is currently setup as an output, instructions can still be used to read the output register. However, it should be noted that the program will in fact only read the status of the output data latch and not the actual logic status of the output pin when the IECM is set to “0”.

• **PxC Register**

Bit	7	6	5	4	3	2	1	0
Name	PxC7	PxC6	PxC5	PxC4	PxC3	PxC2	PxC1	PxC0
R/W	R/W	R/W	R/W	R/W	R/W	R/W	R/W	R/W
POR	1	1	1	1	1	1	1	1

PxCn: I/O Port x Pin type selection
 0: Output
 1: Input

The PxCn bit is used to control the pin type selection. Here the “x” is the Port name which can be A, B, C or D. However, the actual available bits for each I/O Port may be different.

I/O Port Power Source Control

Each device supports different I/O port power source selections for PC3~PC0 pins. With the exception of $\overline{\text{RES}}$ /OCDS, the multi-power function is only available when the pin function is selected as digital input or output function.

The port power can come from the power pin VDD or VDDIO, which is determined using the PMPS1~PMPS0 bits in the PMPS register. The VDDIO power pin function should first be selected using the corresponding pin-shared function selection bits if the port power is supposed to come from the VDDIO pin.

An important point to know is that the input power voltage on the VDDIO pin should be equal to or less than the device supply power voltage V_{DD} when the VDDIO pin is selected as the port power supply pin.

• **PMPS Register**

Bit	7	6	5	4	3	2	1	0
Name	—	—	—	—	—	—	PMPS1	PMPS0
R/W	—	—	—	—	—	—	R/W	R/W
POR	—	—	—	—	—	—	0	0

Bit 7~2 Unimplemented, read as “0”

Bit 1~0 **PMPS1~PMPS0**: PC3~PC0 pin power supply selection

0x: V_{DD}

1x: V_{DDIO}

If the PA4 pin is switched to the VDDIO function, and the PMPS1 and PMPS0 bits are set to “1x”, the VDDIO pin input voltage can be used for PC3~PC0 pin power.

Pin-shared Functions

The flexibility of the microcontroller range is greatly enhanced by the use of pins that have more than one function. Limited numbers of pins can force serious design constraints on designers but by supplying pins with multi-functions, many of these difficulties can be overcome. For these pins, the desired function of the multi-function I/O pins is selected by a series of registers via the application program control.

Pin-shared Function Selection Registers

The limited number of supplied pins in a package can impose restrictions on the amount of functions a certain device can contain. However by allowing the same pins to share several different functions and providing a means of function selection, a wide range of different functions can be incorporated into even relatively small package sizes. These devices include Port “x” Output Function Selection register “n”, labeled as PxSn, and Input Function Selection register “i”, labeled as IFSi, which can select the desired functions of the multi-function pin-shared pins.

The most important point to note is to make sure that the desired pin-shared function is properly selected and also deselected. For most pin-shared functions, to select the desired pin-shared function, the pin-shared function should first be correctly selected using the corresponding pin-shared control register. After that the corresponding peripheral functional setting should be configured and then the peripheral function can be enabled. However, a special point must be noted for some digital input pins, such as INTn, xTCKn, STPI, etc, which share the same pin-shared control configuration with their corresponding general purpose I/O functions when setting the relevant pin-shared control bit fields. To select these pin functions, in addition to the necessary pin-shared control and peripheral functional setup aforementioned, they must also be setup as an input by setting the corresponding bit in the I/O port control register. To correctly deselect the pin-shared function, the peripheral function should first be disabled and then the corresponding pin-shared function control register can be modified to select other pin-shared functions.

Register Name	Bit							
	7	6	5	4	3	2	1	0
PAS0	PAS07	PAS06	PAS05	PAS04	PAS03	PAS02	PAS01	PAS00
PAS1	PAS17	PAS16	PAS15	PAS14	PAS13	PAS12	PAS11	PAS10
PBS0	PBS07	PBS06	PBS05	PBS04	PBS03	PBS02	PBS01	PBS00
PBS1	PBS17	PBS16	PBS15	PBS14	PBS13	PBS12	PBS11	PBS10
PCS0	PCS07	PCS06	PCS05	PCS04	PCS03	PCS02	PCS01	PCS00
PCS1	—	—	—	—	PCS13	PCS12	PCS11	PCS10
IFS0	—	—	PTCK0PS	—	—	—	—	STCKPS
IFS1	—	—	—	—	—	—	—	STPIPS
IFS2	—	—	—	—	—	—	INT1PS	INT0PS

Pin-shared Function Selection Register List – HT67L2540A

Register Name	Bit							
	7	6	5	4	3	2	1	0
PAS0	PAS07	PAS06	PAS05	PAS04	PAS03	PAS02	PAS01	PAS00
PAS1	PAS17	PAS16	PAS15	PAS14	PAS13	PAS12	PAS11	PAS10
PBS0	PBS07	PBS06	PBS05	PBS04	PBS03	PBS02	PBS01	PBS00
PBS1	PBS17	PBS16	PBS15	PBS14	PBS13	PBS12	PBS11	PBS10
PCS0	PCS07	PCS06	PCS05	PCS04	PCS03	PCS02	PCS01	PCS00
PCS1	—	—	—	—	PCS13	PCS12	PCS11	PCS10
PDS0	PDS07	PDS06	PDS05	PDS04	—	—	—	—
IFS0	—	PTCK1PS	PTCK0PS	—	—	—	—	STCKPS
IFS1	—	—	—	—	—	—	—	STPIPS
IFS2	—	—	—	—	—	—	INT1PS	INT0PS

Pin-shared Function Selection Register List – HT67L2550A

• **PAS0 Register**

Bit	7	6	5	4	3	2	1	0
Name	PAS07	PAS06	PAS05	PAS04	PAS03	PAS02	PAS01	PAS00
R/W	R/W	R/W	R/W	R/W	R/W	R/W	R/W	R/W
POR	0	0	0	0	0	0	0	0

- Bit 7~6 **PAS07~PAS06:** PA3 Pin-shared function selection
00: PA3/INT0
01: PA3/INT0
10: PTP0
11: SEG6
- Bit 5~4 **PAS05~PAS04:** PA2 Pin-shared function selection
00: PA2
01: PA2
10: PA2
11: SEG4
- Bit 3~2 **PAS03~PAS02:** PA1 Pin-shared function selection
00: PA1/INT1
01: PA1/INT1
10: STP
11: SEG5
- Bit 1~0 **PAS01~PAS00:** PA0 Pin-shared function selection
00: PA0
01: PA0
10: PA0
11: SEG3

• **PAS1 Register**

Bit	7	6	5	4	3	2	1	0
Name	PAS17	PAS16	PAS15	PAS14	PAS13	PAS12	PAS11	PAS10
R/W	R/W	R/W	R/W	R/W	R/W	R/W	R/W	R/W
POR	0	0	0	0	0	0	0	0

- Bit 7~6 **PAS17~PAS16:** PA7 Pin-shared function selection
 00: PA7
 01: PA7
 10: OSC2
 11: SEG8
- Bit 5~4 **PAS15~PAS14:** PA6 Pin-shared function selection
 00: PA6
 01: PA6
 10: OSC1
 11: SEG9
- Bit 3~2 **PAS13~PAS12:** PA5 Pin-shared function selection
 00: PA5/STCK
 01: PA5/STCK
 10: PA5/STCK
 11: SEG7
- Bit 1~0 **PAS11~PAS10:** PA4 Pin-shared function selection
 00: PA4/PTCK0
 01: PA4/PTCK0
 10: PA4/PTCK0
 11: VDDIO

• **PBS0 Register – HT67L2540A**

Bit	7	6	5	4	3	2	1	0
Name	PBS07	PBS06	PBS05	PBS04	PBS03	PBS02	PBS01	PBS00
R/W	R/W	R/W	R/W	R/W	R/W	R/W	R/W	R/W
POR	0	0	0	0	0	0	0	0

- Bit 7~6 **PBS07~PBS06:** PB3 Pin-shared function selection
 00: PB3
 01: PB3
 10: PB3
 11: AN3
- Bit 5~4 **PBS05~PBS04:** PB2 Pin-shared function selection
 00: PB2/PTCK0
 01: PB2/PTCK0
 10: PB2/PTCK0
 11: AN2
- Bit 3~2 **PBS03~PBS02:** PB1 Pin-shared function selection
 00: PB1/STCK
 01: PB1/STCK
 10: PB1/STCK
 11: AN1
- Bit 1~0 **PBS01~PBS00:** PB0 Pin-shared function selection
 00: PB0
 01: PB0
 10: AN0
 11: VREF

• **PBS0 Register – HT67L2550A**

Bit	7	6	5	4	3	2	1	0
Name	PBS07	PBS06	PBS05	PBS04	PBS03	PBS02	PBS01	PBS00
R/W	R/W	R/W	R/W	R/W	R/W	R/W	R/W	R/W
POR	0	0	0	0	0	0	0	0

Bit 7~6 **PBS07~PBS06:** PB3 Pin-shared function selection

00: PB3/PTCK1
01: PB3/PTCK1
10: PB3/PTCK1
11: AN3

Bit 5~4 **PBS05~PBS04:** PB2 Pin-shared function selection

00: PB2/PTCK0
01: PB2/PTCK0
10: PB2/PTCK0
11: AN2

Bit 3~2 **PBS03~PBS02:** PB1 Pin-shared function selection

00: PB1/STCK
01: PB1/STCK
10: PB1/STCK
11: AN1

Bit 1~0 **PBS01~PBS00:** PB0 Pin-shared function selection

00: PB0
01: PB0
10: AN0
11: VREF

• **PBS1 Register**

Bit	7	6	5	4	3	2	1	0
Name	PBS17	PBS16	PBS15	PBS14	PBS13	PBS12	PBS11	PBS10
R/W	R/W	R/W	R/W	R/W	R/W	R/W	R/W	R/W
POR	0	0	0	0	0	0	0	0

Bit 7~6 **PBS17~PBS16:** PB7 Pin-shared function selection

00: PB7/RES
01: PB7/RES
10: PB7/RES
11: AN7

Note that the RSTC register configuration has higher priority than the pin-shared control.

Bit 5~4 **PBS15~PBS14:** PB6 Pin-shared function selection

00: PB6/STPI
01: PB6/STPI
10: PB6/STPI
11: AN6

Bit 3~2 **PBS13~PBS12:** PB5 Pin-shared function selection

00: PB5/INT1
01: PB5/INT1
10: STPB
11: AN5

Bit 1~0 **PBS11~PBS10:** PB4 Pin-shared function selection

00: PB4/INT0
01: PB4/INT0
10: PTP0B
11: AN4

• **PCS0 Register**

Bit	7	6	5	4	3	2	1	0
Name	PCS07	PCS06	PCS05	PCS04	PCS03	PCS02	PCS01	PCS00
R/W	R/W	R/W	R/W	R/W	R/W	R/W	R/W	R/W
POR	0	0	0	0	0	0	0	0

Bit 7~6 **PCS07~PCS06:** PC3 Pin-shared function selection

- 00: PC3
- 01: PC3
- 10: SCK/SCL
- 11: SEG2

Bit 5~4 **PCS05~PCS04:** PC2 Pin-shared function selection

- 00: PC2
- 01: PC2
- 10: SDO/UTX
- 11: SEG1

Bit 3~2 **PCS03~PCS02:** PC1 Pin-shared function selection

- 00: PC1
- 01: PC1
- 10: SDI/SDA/URX/UTX
- 11: SEG0

Bit 1~0 **PCS01~PCS00:** PC0 Pin-shared function selection

- 00: PC0/STPI
- 01: PC0/STPI
- 10: PC0/STPI
- 11: SCS

• **PCS1 Register**

Bit	7	6	5	4	3	2	1	0
Name	—	—	—	—	PCS13	PCS12	PCS11	PCS10
R/W	—	—	—	—	R/W	R/W	R/W	R/W
POR	—	—	—	—	0	0	0	0

Bit 7~4 Unimplemented, read as “0”

Bit 3~2 **PCS13~PCS12:** PC5 Pin-shared function selection

- 00: PC5
- 01: PC5
- 10: PC5
- 11: XT1

Bit 1~0 **PCS11~PCS10:** PC4 Pin-shared function selection

- 00: PC4
- 01: PC4
- 10: PC4
- 11: XT2

• **PDS0 Register – HT67L2550A**

Bit	7	6	5	4	3	2	1	0
Name	PDS07	PDS06	PDS05	PDS04	—	—	—	—
R/W	R/W	R/W	R/W	R/W	—	—	—	—
POR	0	0	0	0	—	—	—	—

Bit 7~6 **PDS07~PDS06:** PD3 Pin-shared function selection

00: PD3
 01: PD3
 10: PD3
 11: PTP1B

Bit 5~4 **PDS05~PDS04:** PD2 Pin-shared function selection

00: PD2
 01: PD2
 10: PD2
 11: PTP1

Bit 3~0 Unimplemented, read as “0”

• **IFS0 Register – HT67L2540A**

Bit	7	6	5	4	3	2	1	0
Name	—	—	PTCK0PS	—	—	—	—	STCKPS
R/W	—	—	R/W	—	—	—	—	R/W
POR	—	—	0	—	—	—	—	0

Bit 7~6 Unimplemented, read as “0”

Bit 5 **PTCK0PS:** PTCK0 input source pin selection

0: PA4
 1: PB2

Bit 4~1 Unimplemented, read as “0”

Bit 0 **STCKPS:** STCK input source pin selection

0: PA5
 1: PB1

• **IFS0 Register – HT67L2550A**

Bit	7	6	5	4	3	2	1	0
Name	—	PTCK1PS	PTCK0PS	—	—	—	—	STCKPS
R/W	—	R/W	R/W	—	—	—	—	R/W
POR	—	0	0	—	—	—	—	0

Bit 7 Unimplemented, read as “0”

Bit 6 **PTCK1PS:** PTCK1 input source pin selection

0: PD0
 1: PB3

Bit 5 **PTCK0PS:** PTCK0 input source pin selection

0: PA4
 1: PB2

Bit 4~1 Unimplemented, read as “0”

Bit 0 **STCKPS:** STCK input source pin selection

0: PA5
 1: PB1

• **IFS1 Register**

Bit	7	6	5	4	3	2	1	0
Name	—	—	—	—	—	—	—	STPIPS
R/W	—	—	—	—	—	—	—	R/W
POR	—	—	—	—	—	—	—	0

- Bit 7~1 Unimplemented, read as “0”
- Bit 0 **STPIPS**: STPI input source pin selection
0: PB6
1: PC0

• **IFS2 Register**

Bit	7	6	5	4	3	2	1	0
Name	—	—	—	—	—	—	INT1PS	INT0PS
R/W	—	—	—	—	—	—	R/W	R/W
POR	—	—	—	—	—	—	0	0

- Bit 7~2 Unimplemented, read as “0”
- Bit 1 **INT1PS**: INT1 input source pin selection
0: PA1
1: PB5
- Bit 0 **INT0PS**: INT0 input source pin selection
0: PA3
1: PB4

I/O Pin Structures

The accompanying diagram illustrates the internal structure of the I/O logic function. As the exact logical construction of the I/O pin will differ from this drawing, it is supplied as a guide only to assist with the functional understanding of the I/O logic function. The wide range of pin-shared structures does not permit all types to be shown.

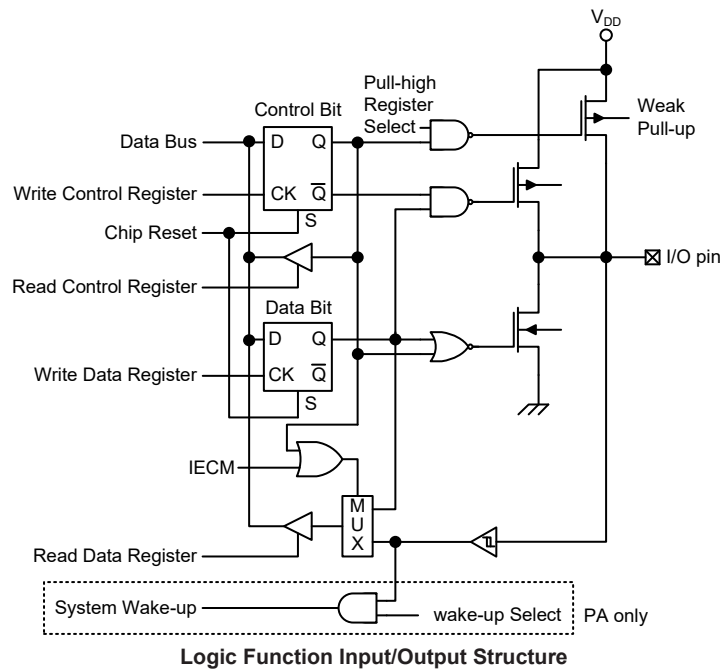

READ PORT Function

The READ PORT function is used to manage the reading of the output data from the data latch or I/O pin, which is specially designed for the IEC60730 self-diagnostic test on the I/O function and A/D paths. There is a register, IECC, which is used to control the READ PORT function. If the READ PORT function is disabled, the pin function will operate as the selected pin-shared function. When a specific data pattern, “11001010”, is written into the IECC register, the internal signal named IECM will be set high to enable the READ PORT function. If the READ PORT function is enabled, the value on the corresponding pins will be passed to the accumulator ACC when the read port instruction “mov acc, Px” is executed where the “x” stands for the corresponding I/O port name.

• IECC Register

Bit	7	6	5	4	3	2	1	0
Name	IECS7	IECS6	IECS5	IECS4	IECS3	IECS2	IECS1	IECS0
R/W	R/W	R/W	R/W	R/W	R/W	R/W	R/W	R/W
POR	0	0	0	0	0	0	0	0

Bit 7~0 **IECS7~IECS0**: READ PORT function enable control bit 7 ~ bit 0
 11001010: IECM=1 – READ PORT function is enabled
 Others: IECM=0 – READ PORT function is disabled

READ PORT Function	Disabled		Enabled	
Port Control Register Bit – PxC.n	1	0	1	0
I/O Function	Pin value	Data latch value	Pin value	
Digital Input Function				
Digital Output Function (except USIM)				
USIM: SCK/SCL, SDI/SDA, URX/UTX, UTX				
Analog Function				
RES	0			

Note: The value in the above table is the content of the ACC register after “mov a, Px” instruction is executed where “x” means the relevant port name.

The additional function of the READ PORT mode is to check the A/D path. When the READ PORT function is disabled, the A/D path from the external pin to the internal analog input will be switched off if the A/D input pin function is not selected by the corresponding selection bits. For the MCU with A/D converter channels, such as A/D AN7~AN0, the desired A/D channel can be switched on by properly configuring the external analog input channel selection bits in the A/D Control Register together with the corresponding analog input pin function is selected. However, the additional function of the READ PORT mode is to force the A/D path to be switched on. For example, when the AN0 is selected as the analog input channel as the READ PORT function is enabled, the AN0 analog input path will be switched on even if the AN0 analog input pin function is not selected. In this way, the AN0 analog input path can be examined by internally connecting the digital output on this shared pin with the AN0 analog input pin switch and then converting the corresponding digital data without any external analog input voltage connected.

Note that the A/D converter reference voltage should be equal to the I/O power supply voltage when examining the A/D path using the READ PORT function.

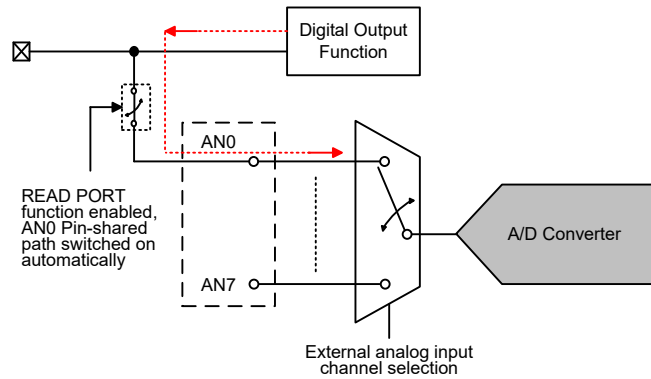

A/D Channel Input Path Internally Connection

Programming Considerations

Within the user program, one of the first things to consider is port initialisation. After a reset, all of the I/O data and port control registers will be set high. This means that all I/O pins will default to an input state, the level of which depends on the other connected circuitry and whether pull-high selections have been chosen. If the port control registers are then programmed to setup some pins as outputs, these output pins will have an initial high output value unless the associated port data registers are first programmed. Selecting which pins are inputs and which are outputs can be achieved byte-wide by loading the correct values into the appropriate port control register or by programming individual bits in the port control register using the “SET [m].i” and “CLR [m].i” instructions. Note that when using these bit control instructions, a read-modify-write operation takes place. The microcontroller must first read in the data on the entire port, modify it to the required new bit values and then rewrite this data back to the output ports.

Port A has the additional capability of providing wake-up function. When the device is in the SLEEP or IDLE Mode, various methods are available to wake the device up. One of these is a high to low transition of any of the Port A pins. Single or multiple pins on Port A can be setup to have this function.

Timer Modules – TM

One of the most fundamental functions in any microcontroller devices is the ability to control and measure time. To implement time related functions the devices include several Timer Modules, abbreviated to the name TM. The TMs are multi-purpose timing units and serve to provide operations such as Timer/Counter, Input Capture, Compare Match Output and Single Pulse Output as well as being the functional unit for the generation of PWM signals. Each of the TMs has two interrupts. The addition of input and output pins for each TM ensures that users are provided with timing units with a wide and flexible range of features.

The common features of the different TM types are described here with more detailed information provided in the individual Standard and Periodic TM sections.

Introduction

These devices contain several TMs and each individual TM can be categorised as a certain type, namely Standard Type TM or Periodic Type TM. Although similar in nature, the different TM types vary in their feature complexity. The common features to all of the Standard and Periodic TMs will be described in this section. The detailed operation regarding each of the TM types will be described in separate sections. The main features and differences between the two types of TMs are summarised in the accompanying table.

TM Function	STM	PTM
Timer/Counter	√	√
Input Capture	√	—
Compare Match Output	√	√
PWM Output	√	√
Single Pulse Output	√	√
PWM Alignment	Edge	Edge
PWM Adjustment Period & Duty	Duty or Period	Duty or Period

TM Function Summary

Device	STM	PTM
HT67L2540A	STM	PTM0
HT67L2550A	STM	PTM0, PTM1

TM Name/Type Summary

TM Operation

The different types of TM offer a diverse range of functions, from simple timing operations to PWM signal generation. The key to understanding how the TM operates is to see it in terms of a free running counter whose value is then compared with the value of pre-programmed internal comparators. When the free running counter has the same value as the pre-programmed comparator, known as a compare match situation, a TM interrupt signal will be generated which can clear the counter and perhaps also change the condition of the TM output pin. The internal TM counter is driven by a user selectable clock source, which can be an internal clock or an external pin.

TM Clock Source

The clock source which drives the main counter in each TM can originate from various sources. The selection of the required clock source is implemented using the xTnCK2~xTnCK0 bits in the xTMn control registers, where “x” stands for S or P type TM and “n” stands for the specific TM serial number. For the STM there is no serial number “n” in the relevant pins, registers and control bits since there is only one STM in the devices. The clock source can be a ratio of the system clock f_{SYS} or the internal high clock f_H , the f_{SUB} clock source or the external xTCKn pin. The xTCKn pin clock source is used to allow an external signal to drive the TM as an external clock source or for event counting.

TM Interrupts

The Standard or Periodic type TM has two internal interrupt, one for each of the internal comparator A or comparator P, which generate a TM interrupt when a compare match condition occurs. When a TM interrupt is generated, it can be used to clear the counter and also to change the state of the TM output pin.

TM External Pins

Each of the TMs, irrespective of what type, has one TM input pin, with the label xTCKn while the STM has another input pin with the label STPI. The xTMn input pin, xTCKn, is essentially a clock source for the xTMn and is selected using the xTnCK2~xTnCK0 bits in the xTMnC0 register. This external TM input pin allows an external clock source to drive the internal TM. The xTCKn input pin can be chosen to have either a rising or falling active edge. The xTCKn pin is also used as the external trigger input pin in single pulse output mode for the xTMn.

The other STM input pin, STPI, which is the capture input whose active edge can be a rising edge, a falling edge or both rising and falling edges and the active edge transition type is selected using the STIO1~STIO0 bits in the STMC1 register.

The TMs each has two output pins with the label xTPn and xTPnB. When the TM is in the Compare Match Output Mode, the xTPn pin can be controlled by the TM to switch to a high or low level or to toggle when a compare match situation occurs. The xTPnB pin outputs the inverted signal of the xTPn. The external xTPn and xTPnB output pins are also the pins where the TM generates the PWM output waveform.

As the TM input and output pins are pin-shared with other functions, the TM input and output functions must first be setup using the relevant pin-shared function selection bits. The details of the pin-shared function selection are described in the pin-shared function section.

Device	STM		PTM	
	Input	Output	Input	Output
HT67L2540A	STCK, STPI	STP, STPB	PTCK0	PTP0, PTP0B
HT67L2550A	STCK, STPI	STP, STPB	PTCK0; PTCK1	PTP0, PTP0B; PTP1, PTP1B

TM External Pins

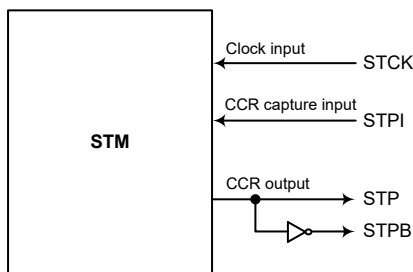

STM Function Pin Block Diagram

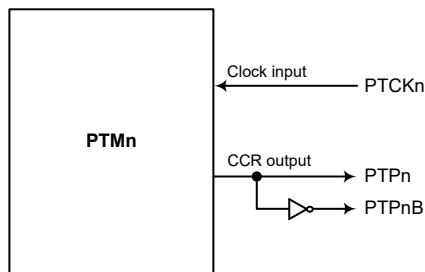

PTM Function Pin Block Diagram (n=0~1)

Programming Considerations

The TM Counter Registers and the Capture/Compare CCRA and CCRP registers, all have a low and high byte structure. The high bytes can be directly accessed, but as the low bytes can only be accessed via an internal 8-bit buffer, reading or writing to these register pairs must be carried out in a specific way. The important point to note is that data transfer to and from the 8-bit buffer and its related low byte only takes place when a write or read operation to its corresponding high byte is executed.

As the CCRA and CCRP registers are implemented in the way shown in the following diagram and accessing these register pairs is carried out in a specific way as described above, it is recommended to use the “MOV” instruction to access the CCRA and CCRP low byte registers, named xTMnAL and PTMnRPL, using the following access procedures. Accessing the CCRA or CCRP low byte registers without following these access procedures will result in unpredictable values.

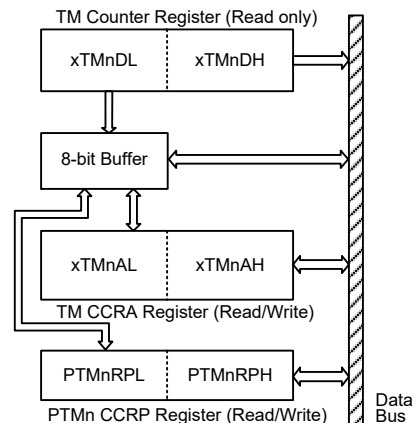

The following steps show the read and write procedures:

- Writing Data to CCRA or CCRP
 - ♦ Step 1. Write data to Low Byte xTMnAL or PTMnRPL
 - Note that here data is only written to the 8-bit buffer.
 - ♦ Step 2. Write data to High Byte xTMnAH or PTMnRPH
 - Here data is written directly to the high byte registers and simultaneously data is latched from the 8-bit buffer to the Low Byte registers.
- Reading Data from the Counter Registers and CCRA or CCRP
 - ♦ Step 1. Read data from the High Byte xTMnDH, xTMnAH or PTMnRPH
 - Here data is read directly from the High Byte registers and simultaneously data is latched from the Low Byte register into the 8-bit buffer.
 - ♦ Step 2. Read data from the Low Byte xTMnDL, xTMnAL or PTMnRPL
 - This step reads data from the 8-bit buffer.

Standard Type TM – STM

The Standard Type TM contains five operating modes, which are Compare Match Output, Timer/Event Counter, Capture Input, Single Pulse Output and PWM Output modes. The Standard TM can also be controlled with two external input pins and can drive two external output pins.

Device	STM Core	STM Input Pins	STM Output Pins
HT67L2540A	16-bit STM	STCK, STPI	STP, STPB
HT67L2550A		STCK, STPI	STP, STPB

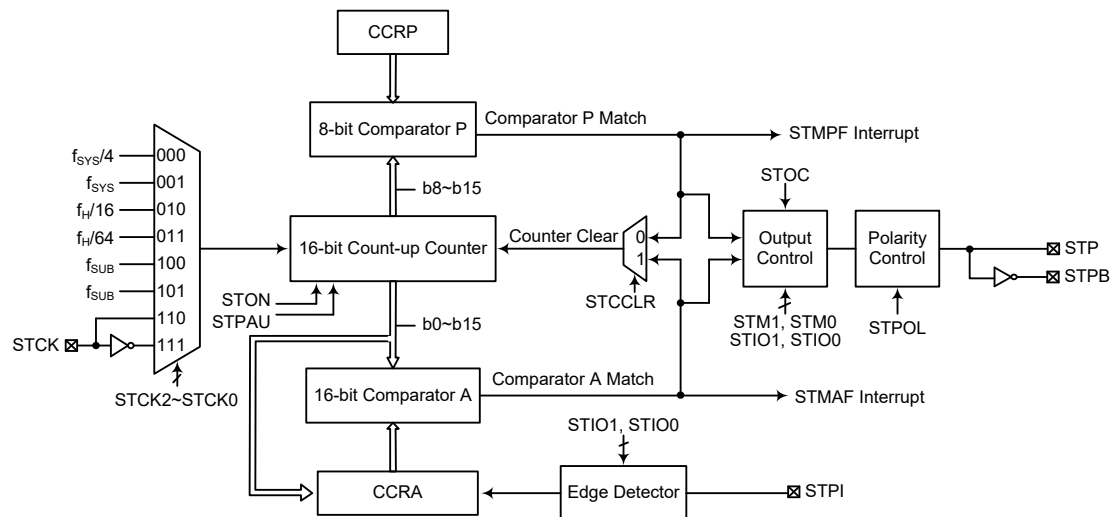

Note: 1. The STM external pins are pin-shared with other functions, so before using the STM function, ensure that the relevant pin-shared function registers have been set properly to enable the STM pin function. The STCK and STPI pins, if used, must also be set as an input by setting the corresponding bits in the port control register.

2. The STPB is the inverted signal of the STP.

16-bit Standard Type TM Block Diagram

Standard Type TM Operation

The size of Standard TM is 16-bit wide and its core is a 16-bit count-up counter which is driven by a user selectable internal or external clock source. There are also two internal comparators with the names, Comparator A and Comparator P. These comparators will compare the value in the counter with CCRP and CCRA registers. The CCRP comparator is 8-bit wide whose value is compared with the highest 8 bits in the counter while the CCRA is the sixteen bits and therefore compares all counter bits.

The only way of changing the value of the 16-bit counter using the application program, is to clear the counter by changing the STON bit from low to high. The counter will also be cleared automatically by a counter overflow or a compare match with one of its associated comparators. When these conditions occur, an STM interrupt signal will also usually be generated. The Standard Type TM can operate in a number of different operational modes, can be driven by different clock sources including two input pins and can also control the output pins. All operating setup conditions are selected using relevant internal registers.

Standard Type TM Register Description

Overall operation of the Standard TM is controlled using a series of registers. A read only register pair exists to store the internal counter 16-bit value, while a read/write register pair exists to store the internal 16-bit CCRA value. The STMRP register is used to store the 8-bit CCRP value. The remaining two registers are control registers which set the different operating and control modes.

Register Name	Bit							
	7	6	5	4	3	2	1	0
STMC0	STPAU	STCK2	STCK1	STCK0	STON	—	—	—
STMC1	STM1	STM0	STIO1	STIO0	STOC	STPOL	STDPX	STCCLR
STMDL	D7	D6	D5	D4	D3	D2	D1	D0
STMDH	D15	D14	D13	D12	D11	D10	D9	D8
STMAL	D7	D6	D5	D4	D3	D2	D1	D0
STMAH	D15	D14	D13	D12	D11	D10	D9	D8
STMRP	D7	D6	D5	D4	D3	D2	D1	D0

16-bit Standard TM Register List

• STMC0 Register

Bit	7	6	5	4	3	2	1	0
Name	STPAU	STCK2	STCK1	STCK0	STON	—	—	—
R/W	R/W	R/W	R/W	R/W	R/W	—	—	—
POR	0	0	0	0	0	—	—	—

Bit 7 **STPAU**: STM counter pause control

0: Run
1: Pause

The counter can be paused by setting this bit high. Clearing the bit to zero restores normal counter operation. When in a Pause condition the STM will remain powered up and continue to consume power. The counter will retain its residual value when this bit changes from low to high and resume counting from this value when the bit changes to a low value again.

Bit 6~4 **STCK2~STCK0**: STM counter clock selection

000: $f_{SYS}/4$
001: f_{SYS}
010: $f_{H}/16$
011: $f_{H}/64$
100: f_{SUB}
101: f_{SUB}
110: STCK rising edge clock
111: STCK falling edge clock

These three bits are used to select the clock source for the STM. The external pin clock source can be chosen to be active on the rising or falling edge. The clock source f_{SYS} is the system clock, while f_{H} and f_{SUB} are other internal clocks, the details of which can be found in the oscillator section.

Bit 3 **STON**: STM counter on/off control

0: Off
1: On

This bit controls the overall on/off function of the STM. Setting the bit high enables the counter to run while clearing the bit disables the STM. Clearing this bit to zero will stop the counter from counting and turn off the STM which will reduce its power consumption. When the bit changes state from low to high the internal counter value will be reset to zero, however when the bit changes from high to low, the internal counter will retain its residual value until the bit returns high again.

If the STM is in the Compare Match Output Mode, PWM Output Mode or Single Pulse Output Mode, then the STM output pin will be reset to its initial condition, as specified by the STOC bit, when the STON bit changes from low to high.

Bit 2~0 Unimplemented, read as “0”

• **STMC1 Register**

Bit	7	6	5	4	3	2	1	0
Name	STM1	STM0	STIO1	STIO0	STOC	STPOL	STDPX	STCCLR
R/W	R/W	R/W	R/W	R/W	R/W	R/W	R/W	R/W
POR	0	0	0	0	0	0	0	0

Bit 7~6 **STM1~STM0**: STM operating mode selection
 00: Compare Match Output Mode
 01: Capture Input Mode
 10: PWM Output Mode or Single Pulse Output Mode
 11: Timer/Counter Mode

These bits setup the required operating mode for the STM. To ensure reliable operation the STM should be switched off before any changes are made to the STM1 and STM0 bits. In the Timer/Counter Mode, the STM output pin state is undefined.

Bit 5~4 **STIO1~STIO0**: STM external pin function selection

Compare Match Output Mode
 00: No change
 01: Output low
 10: Output high
 11: Toggle output

PWM Output Mode/Single Pulse Output Mode
 00: PWM output inactive state
 01: PWM output active state
 10: PWM output
 11: Single Pulse Output

Capture Input Mode
 00: Input capture at rising edge of STPI
 01: Input capture at falling edge of STPI
 10: Input capture at both rising/falling edge of STPI
 11: Input capture disabled

Timer/Counter Mode
 Unused

These two bits are used to determine how the STM output pin changes state when a certain condition is reached. The function that these bits select depends upon in which mode the STM is running.

In the Compare Match Output Mode, the STIO1 and STIO0 bits determine how the STM output pin changes state when a compare match occurs from the Comparator A. The TM output pin can be setup to switch high, switch low or to toggle its present state when a compare match occurs from the Comparator A. When the bits are both zero, then no change will take place on the output. The initial value of the STM output pin should be setup using the STOC bit in the STMC1 register. Note that the output level requested by the STIO1 and STIO0 bits must be different from the initial value setup using the STOC bit otherwise no change will occur on the STM output pin when a compare match occurs. After the STM output pin changes state, it can be reset to its initial level by changing the level of the STON bit from low to high.

In the PWM Output Mode, the STIO1 and STIO0 bits determine how the STM output pin changes state when a certain compare match condition occurs. The PWM output function is modified by changing these two bits. It is necessary to change the values of the STIO1 and STIO0 bits only after the STM has been switched off. Unpredictable PWM outputs will occur if the STIO1 and STIO0 bits are changed when the STM is running.

- Bit 3 **STOC**: STM STP output control
Compare Match Output Mode
 0: Initial low
 1: Initial high
PWM Output Mode/Single Pulse Output Mode
 0: Active low
 1: Active high
This is the output control bit for the STM output pin. Its operation depends upon whether STM is being used in the Compare Match Output Mode or in the PWM Output Mode/Single Pulse Output Mode. It has no effect if the STM is in the Timer/Counter Mode. In the Compare Match Output Mode it determines the logic level of the STM output pin before a compare match occurs. In the PWM Output Mode it determines if the PWM signal is active high or active low. In the Single Pulse Output Mode it determines the logic level of the STM output pin when the STON bit changes from low to high.
- Bit 2 **STPOL**: STM STP output polarity control
 0: Non-invert
 1: Invert
This bit controls the polarity of the STP output pin. When the bit is set high the STM output pin will be inverted and not inverted when the bit is zero. It has no effect if the STM is in the Timer/Counter Mode.
- Bit 1 **STDPX**: STM PWM duty/period control
 0: CCRP – period; CCRA – duty
 1: CCRP – duty; CCRA – period
This bit determines which of the CCRA and CCRP registers are used for period and duty control of the PWM waveform.
- Bit 0 **STCCLR**: STM counter clear condition selection
 0: Comparator P match
 1: Comparator A match
This bit is used to select the method which clears the counter. Remember that the Standard TM contains two comparators, Comparator A and Comparator P, either of which can be selected to clear the internal counter. With the STCCLR bit set high, the counter will be cleared when a compare match occurs from the Comparator A. When the bit is low, the counter will be cleared when a compare match occurs from the Comparator P or with a counter overflow. A counter overflow clearing method can only be implemented if the CCRP bits are all cleared to zero. The STCCLR bit is not used in the PWM Output Mode, Single Pulse Output Mode or Capture Input Mode.

• **STMDL Register**

Bit	7	6	5	4	3	2	1	0
Name	D7	D6	D5	D4	D3	D2	D1	D0
R/W	R	R	R	R	R	R	R	R
POR	0	0	0	0	0	0	0	0

Bit 7~0 **D7~D0:** STM Counter Low Byte Register bit 7 ~ bit 0
STM 16-bit Counter bit 7 ~ bit 0

• **STMDH Register**

Bit	7	6	5	4	3	2	1	0
Name	D15	D14	D13	D12	D11	D10	D9	D8
R/W	R	R	R	R	R	R	R	R
POR	0	0	0	0	0	0	0	0

Bit 7~0 **D15~D8:** STM Counter High Byte Register bit 7 ~ bit 0
STM 16-bit Counter bit 15 ~ bit 8

• **STMAL Register**

Bit	7	6	5	4	3	2	1	0
Name	D7	D6	D5	D4	D3	D2	D1	D0
R/W	R/W	R/W	R/W	R/W	R/W	R/W	R/W	R/W
POR	0	0	0	0	0	0	0	0

Bit 7~0 **D7~D0:** STM CCRA Low Byte Register bit 7 ~ bit 0
STM 16-bit CCRA bit 7 ~ bit 0

• **STMAH Register**

Bit	7	6	5	4	3	2	1	0
Name	D15	D14	D13	D12	D11	D10	D9	D8
R/W	R/W	R/W	R/W	R/W	R/W	R/W	R/W	R/W
POR	0	0	0	0	0	0	0	0

Bit 7~0 **D15~D8:** STM CCRA High Byte Register bit 7 ~ bit 0
STM 16-bit CCRA bit 15 ~ bit 8

• **STMRP Register**

Bit	7	6	5	4	3	2	1	0
Name	D7	D6	D5	D4	D3	D2	D1	D0
R/W	R/W	R/W	R/W	R/W	R/W	R/W	R/W	R/W
POR	0	0	0	0	0	0	0	0

Bit 7~0 **D7~D0:** STM CCRP 8-bit register, compared with the STM counter bit 15 ~ bit 8
Comparator P match period=
0: 65536 STM clocks
1~255: (1~255)×256 STM clocks

These eight bits are used to setup the value on the internal CCRP 8-bit register, which are then compared with the internal counter's highest eight bits. The result of this comparison can be selected to clear the internal counter if the STCCLR bit is set to zero. Setting the STCCLR bit to zero ensures that a compare match with the CCRP values will reset the internal counter. As the CCRP bits are only compared with the highest eight counter bits, the compare values exist in 256 clock cycle multiples. Clearing all eight bits to zero is in effect allowing the counter to overflow at its maximum value.

Standard Type TM Operation Modes

The Standard Type TM can operate in one of five operating modes, Compare Match Output Mode, PWM Output Mode, Single Pulse Output Mode, Capture Input Mode or Timer/Counter Mode. The operating mode is selected using the STM1 and STM0 bits in the STMC1 register.

Compare Match Output Mode

To select this mode, bits STM1 and STM0 in the STMC1 register, should be set to “00” respectively. In this mode once the counter is enabled and running it can be cleared by three methods. These are a counter overflow, a compare match from Comparator A and a compare match from Comparator P. When the STCCLR bit is low, there are two ways in which the counter can be cleared. One is when a compare match from Comparator P, the other is when the CCRP bits are all zero which allows the counter to overflow. Here both STMAF and STMPF interrupt request flags for Comparator A and Comparator P respectively, will both be generated.

If the STCCLR bit in the STMC1 register is high then the counter will be cleared when a compare match occurs from Comparator A. However, here only the STMAF interrupt request flag will be generated even if the value of the CCRP bits is less than that of the CCRA registers. Therefore when STCCLR is high no STMPF interrupt request flag will be generated. In the Compare Match Output Mode, the CCRA can not be set to “0”.

If the CCRA bits are all zero, the counter will overflow when it reaches its maximum 16-bit, FFFF Hex, value, however here the STMAF interrupt request flag will not be generated.

As the name of the mode suggests, after a comparison is made, the STM output pin, will change state. The STM output pin condition however only changes state when an STMAF interrupt request flag is generated after a compare match occurs from Comparator A. The STMPF interrupt request flag, generated from a compare match occurs from Comparator P, will have no effect on the STM output pin. The way in which the STM output pin changes state are determined by the condition of the STIO1 and STIO0 bits in the STMC1 register. The STM output pin can be selected using the STIO1 and STIO0 bits to go high, to go low or to toggle from its present condition when a compare match occurs from Comparator A. The initial condition of the STM output pin, which is setup after the STON bit changes from low to high, is setup using the STOC bit. Note that if the STIO1 and STIO0 bits are zero then no pin change will take place.

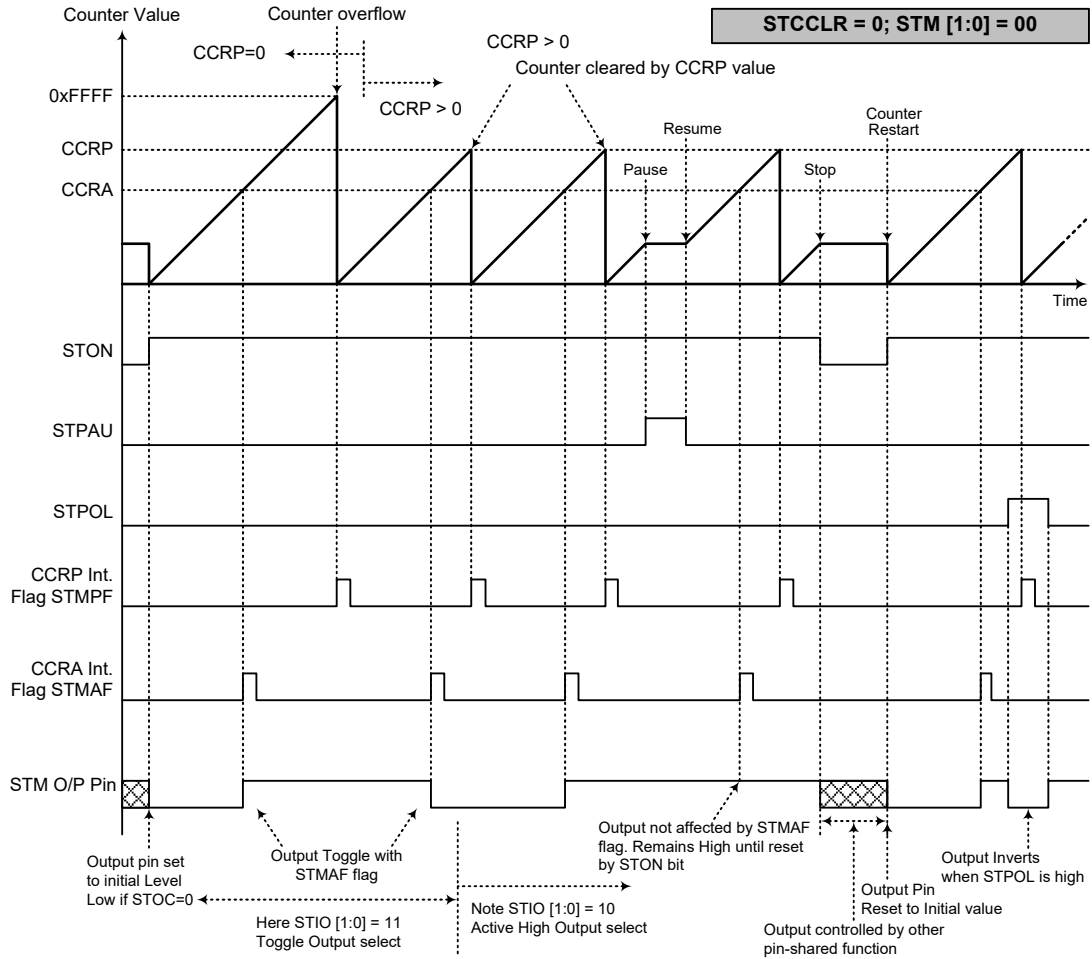

Compare Match Output Mode – STCCLR=0

- Note: 1. With STCCLR=0, a Comparator P match will clear the counter
 2. The STM output pin is controlled only by the STMAF flag
 3. The output pin is reset to its initial state by a STON bit rising edge

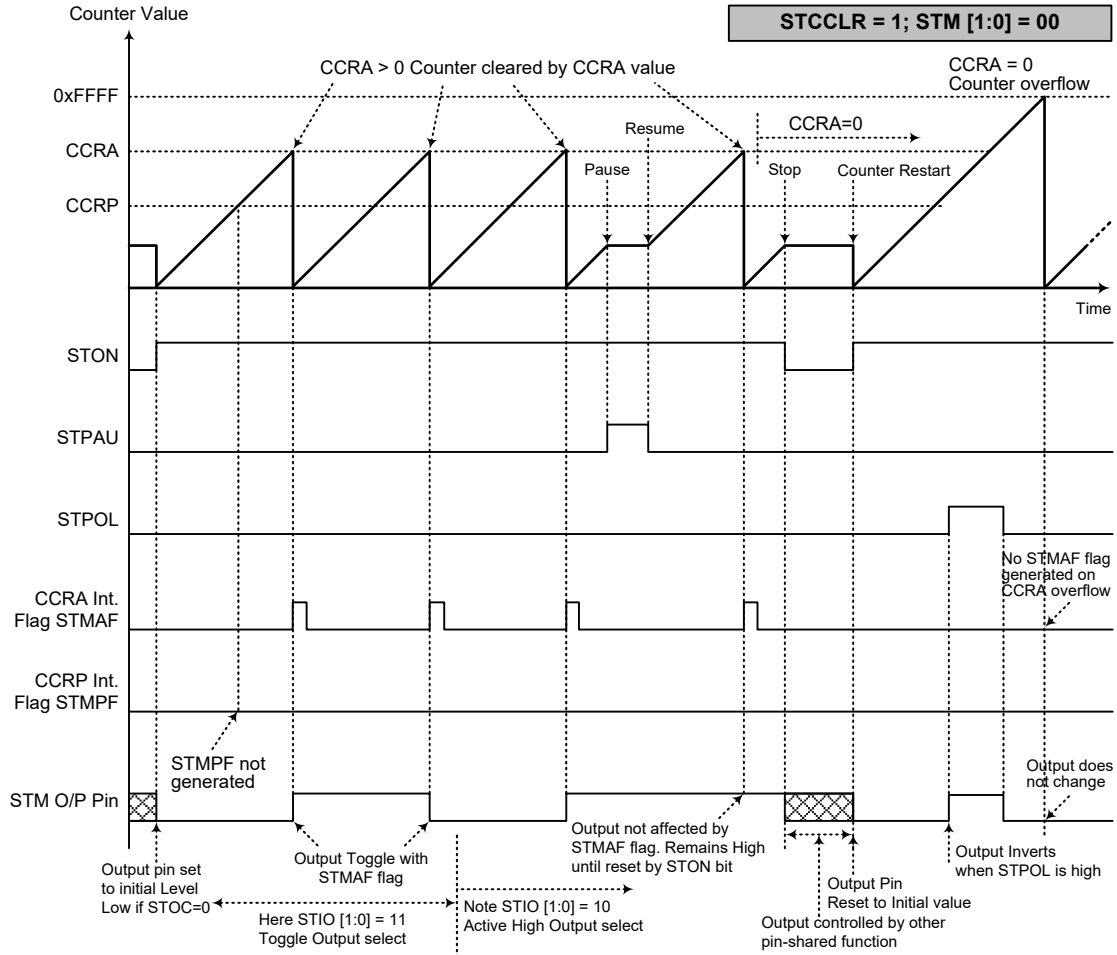

Compare Match Output Mode – STCCLR=1

- Note: 1. With STCCLR=1, a Comparator A match will clear the counter
2. The STM output pin is controlled only by the STMAF flag
3. The output pin is reset to its initial state by a STON bit rising edge
4. The STMPF flag is not generated when STCCLR=1

Timer/Counter Mode

To select this mode, bits STM1 and STM0 in the STMC1 register should be set to “11” respectively. The Timer/Counter Mode operates in an identical way to the Compare Match Output Mode generating the same interrupt flags. The exception is that in the Timer/Counter Mode the STM output pin is not used. Therefore the above description and Timing Diagrams for the Compare Match Output Mode can be used to understand its function. As the STM output pin is not used in this mode, the pin can be used as a normal I/O pin or other pin-shared functions.

PWM Output Mode

To select this mode, bits STM1 and STM0 in the STMC1 register should be set to “10” respectively and also the STIO1 and STIO0 bits should be set to “10” respectively. The PWM function within the STM is useful for applications which require functions such as motor control, heating control, illumination control etc. By providing a signal of fixed frequency but of varying duty cycle on the STM output pin, a square wave AC waveform can be generated with varying equivalent DC RMS values.

As both the period and duty cycle of the PWM waveform can be controlled, the choice of generated waveform is extremely flexible. In the PWM Output Mode, the STCCLR bit has no effect as the PWM period. Both of the CCRA and CCRP registers are used to generate the PWM waveform, one register is used to clear the internal counter and thus control the PWM waveform frequency, while the other one is used to control the duty cycle. Which register is used to control either frequency or duty cycle is determined using the STDPX bit in the STMC1 register. The PWM waveform frequency and duty cycle can therefore be controlled by the values in the CCRA and CCRP registers.

An interrupt flag, one for each of the CCRA and CCRP, will be generated when a compare match occurs from either Comparator A or Comparator P. The STOC bit in the STMC1 register is used to select the required polarity of the PWM waveform while the two STIO1 and STIO0 bits are used to enable the PWM output or to force the STM output pin to a fixed high or low level. The STPOL bit is used to reverse the polarity of the PWM output waveform.

• **16-bit STM, PWM Output Mode, Edge-aligned Mode, STDPX=0**

CCRP	1~255	0
Period	CCRP×256	65536
Duty	CCRA	

If $f_{SYS}=16\text{MHz}$, STM clock source is $f_{SYS}/4$, CCRP=2 and CCRA=128,

The STM PWM output frequency= $(f_{SYS}/4)/(2\times 256)=f_{SYS}/2048\approx 7.8125\text{kHz}$, duty= $128/(2\times 256)=25\%$,

If the Duty value defined by the CCRA register is equal to or greater than the Period value, then the PWM output duty is 100%.

• **16-bit STM, PWM Output Mode, Edge-aligned Mode, STDPX=1**

CCRP	1~255	0
Period	CCRA	
Duty	CCRP×256	65536

The PWM output period is determined by the CCRA register value together with the STM clock while the PWM duty cycle is defined by the CCRP register value.

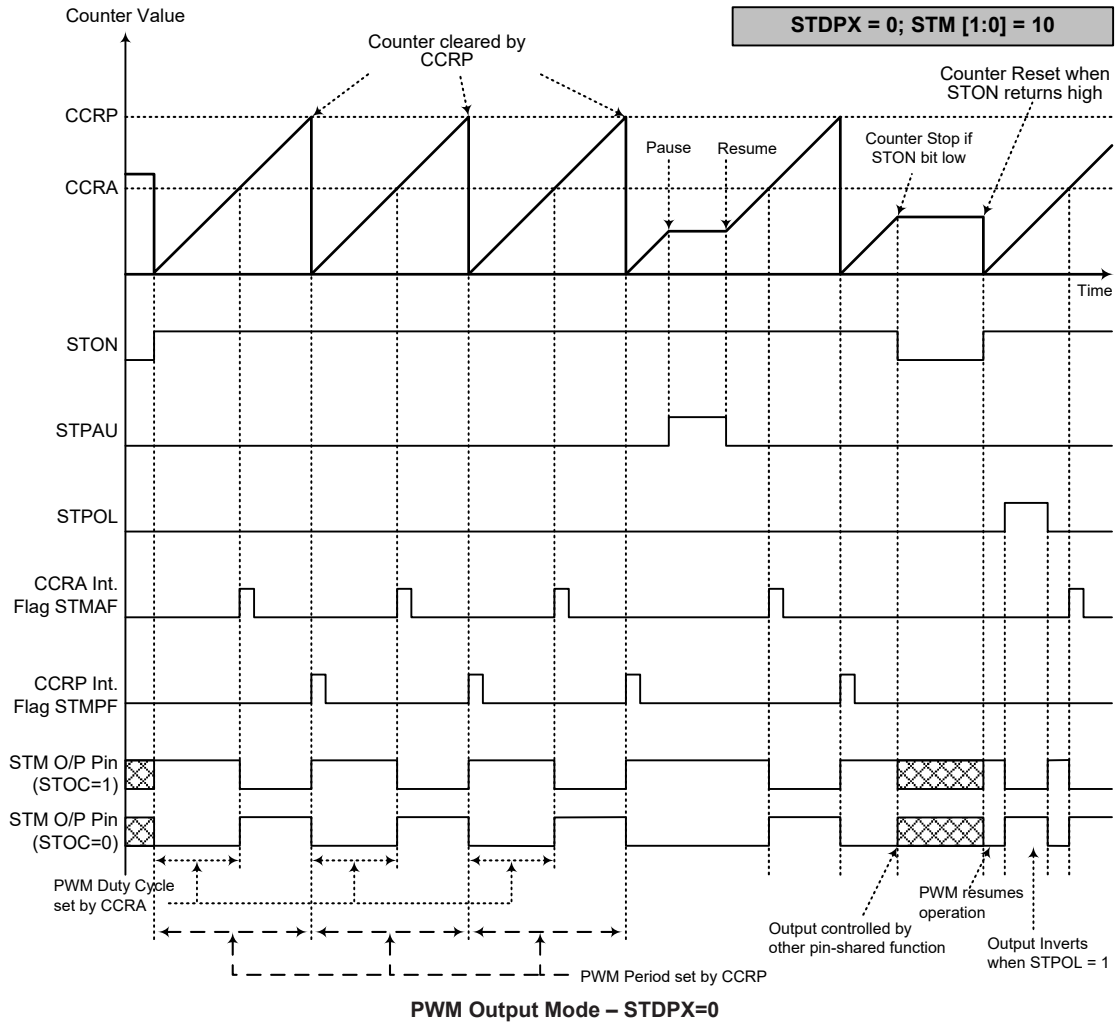

- Note: 1. Here STDPX=0 – Counter cleared by CCRP
 2. A counter clear sets the PWM Period
 3. The internal PWM function continues even when STIO[1:0]=00 or 01
 4. The STCCLR bit has no influence on PWM operation

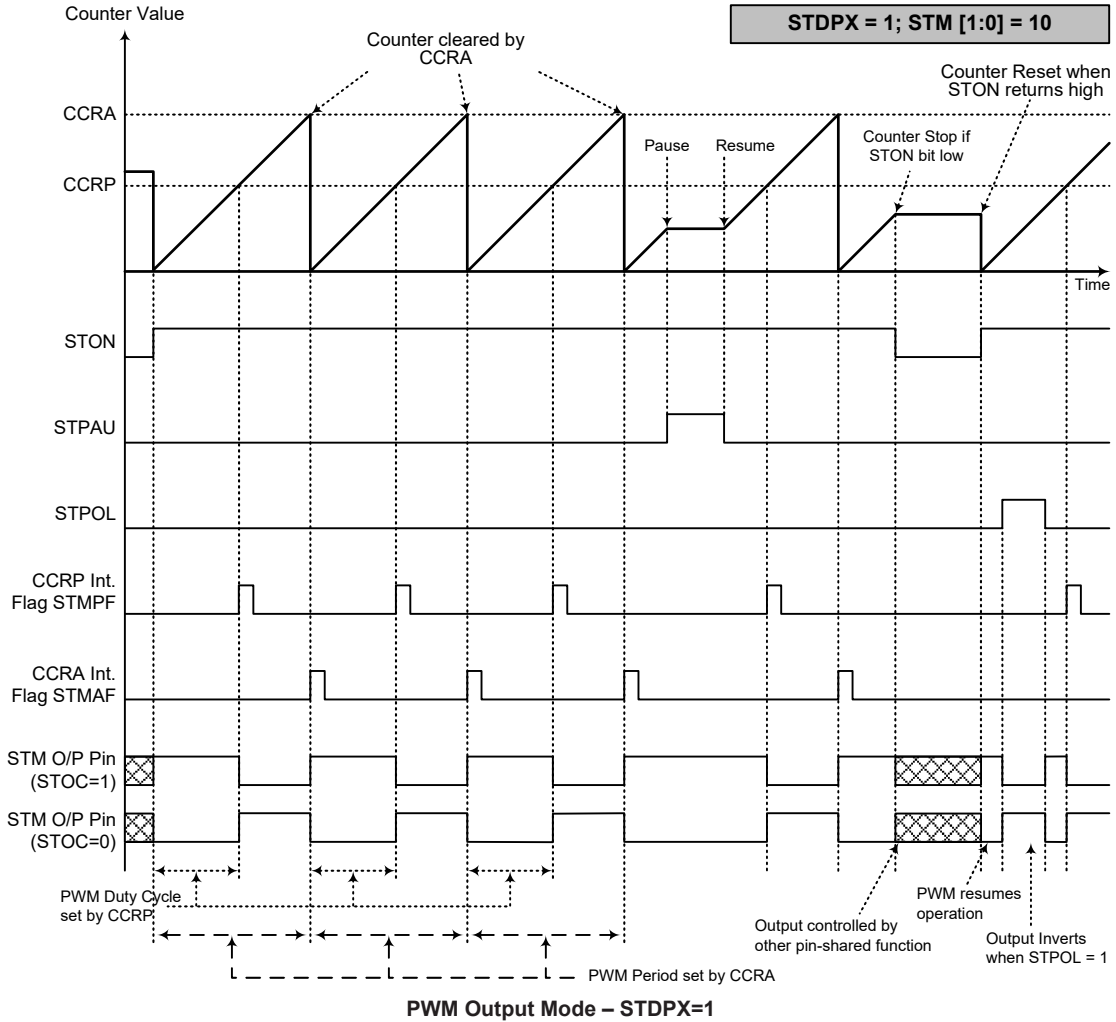

- Note: 1. Here STDPX=1 – Counter cleared by CCRA
 2. A counter clear sets the PWM Period
 3. The internal PWM function continues even when STIO[1:0]=00 or 01
 4. The STCCLR bit has no influence on PWM operation

Single Pulse Output Mode

To select this mode, bits STM1 and STM0 in the STMC1 register should be set to “10” respectively and also the STIO1 and STIO0 bits should be set to “11” respectively. The Single Pulse Output Mode, as the name suggests, will generate a single shot pulse on the STM output pin.

The trigger for the pulse output leading edge is a low to high transition of the STON bit, which can be implemented using the application program. However in the Single Pulse Output Mode, the STON bit can also be made to automatically change from low to high using the external STCK pin, which will in turn initiate the Single Pulse output. When the STON bit transitions to a high level, the counter will start running and the pulse leading edge will be generated. The STON bit should remain high when the pulse is in its active state. The generated pulse trailing edge will be generated when the STON bit is cleared to zero, which can be implemented using the application program or when a compare match occurs from Comparator A.

However a compare match from Comparator A will also automatically clear the STON bit and thus generate the Single Pulse output trailing edge. In this way the CCRA value can be used to control the pulse width. A compare match from Comparator A will also generate an STM interrupt. The counter can only be reset back to zero when the STON bit changes from low to high when the counter restarts. In the Single Pulse Output Mode CCRP is not used. The STCCLR and STDPX bits are not used in this mode.

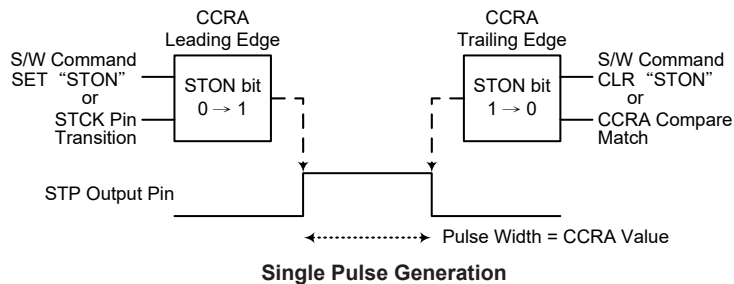

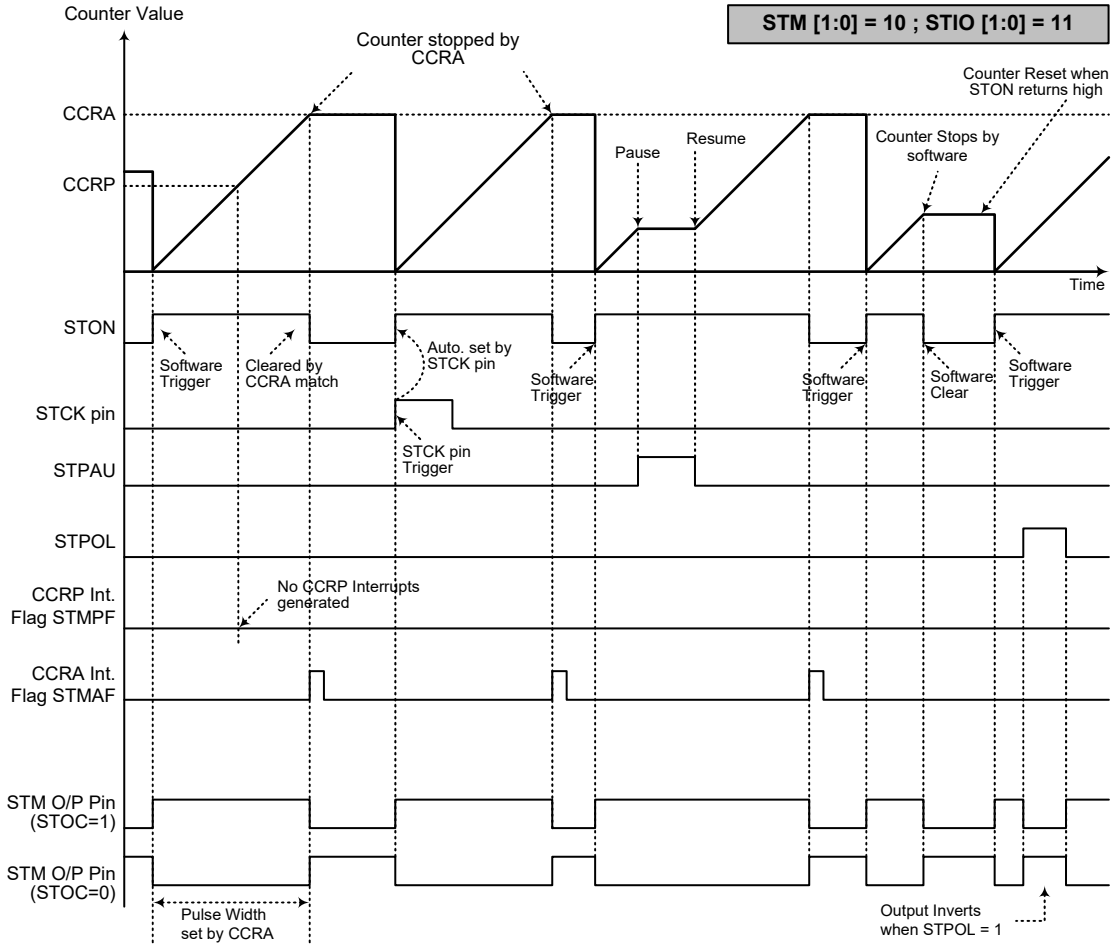

Single Pulse Output Mode

- Note: 1. Counter stopped by CCRA
 2. CCRP is not used
 3. The pulse triggered by the STCK pin or by setting the STON bit high
 4. An STCK pin active edge will automatically set the STON bit high.
 5. In the Single Pulse Output Mode, STIO[1:0] must be set to "11" and can not be changed

Capture Input Mode

To select this mode bits STM1 and STM0 in the STMC1 register should be set to 01 respectively. This mode enables external signals to capture and store the present value of the internal counter and can therefore be used for applications such as pulse width measurements. The external signal is supplied on the STPI pin, whose active edge can be a rising edge, a falling edge or both rising and falling edges; the active edge transition type is selected using the STIO1 and STIO0 bits in the STMC1 register. The counter is started when the STON bit changes from low to high which is initiated using the application program.

When the required edge transition appears on the STPI pin the present value in the counter will be latched into the CCRA registers and a STM interrupt generated. Irrespective of what events occur on the STPI pin the counter will continue to free run until the STON bit changes from high to low. When a CCRP compare match occurs the counter will reset back to zero; in this way the CCRP value can be used to control the maximum counter value. When a CCRP compare match occurs from Comparator P, a STM interrupt will also be generated. Counting the number of overflow interrupt signals from the CCRP can be a useful method in measuring long pulse widths. The STIO1 and STIO0 bits can select the active trigger edge on the STPI pin to be a rising edge, falling edge or both edge types. If the STIO1 and STIO0 bits are both set high, then no capture operation will take place irrespective of what happens on the STPI pin, however it must be noted that the counter will continue to run. The STCCLR and STDPX bits are not used in this mode.

There are some considerations that should be noted. If the captured pulse width is less than 2 timer clock periods, it may be ignored by hardware. After the counter value is latched to the CCRA registers by an active capture edge, the STMAF flag will be set high after 0.5 timer clock period. The delay time from the active capture edge received to the action of latching counter value to CCRA registers is less than 1.5 timer clock periods.

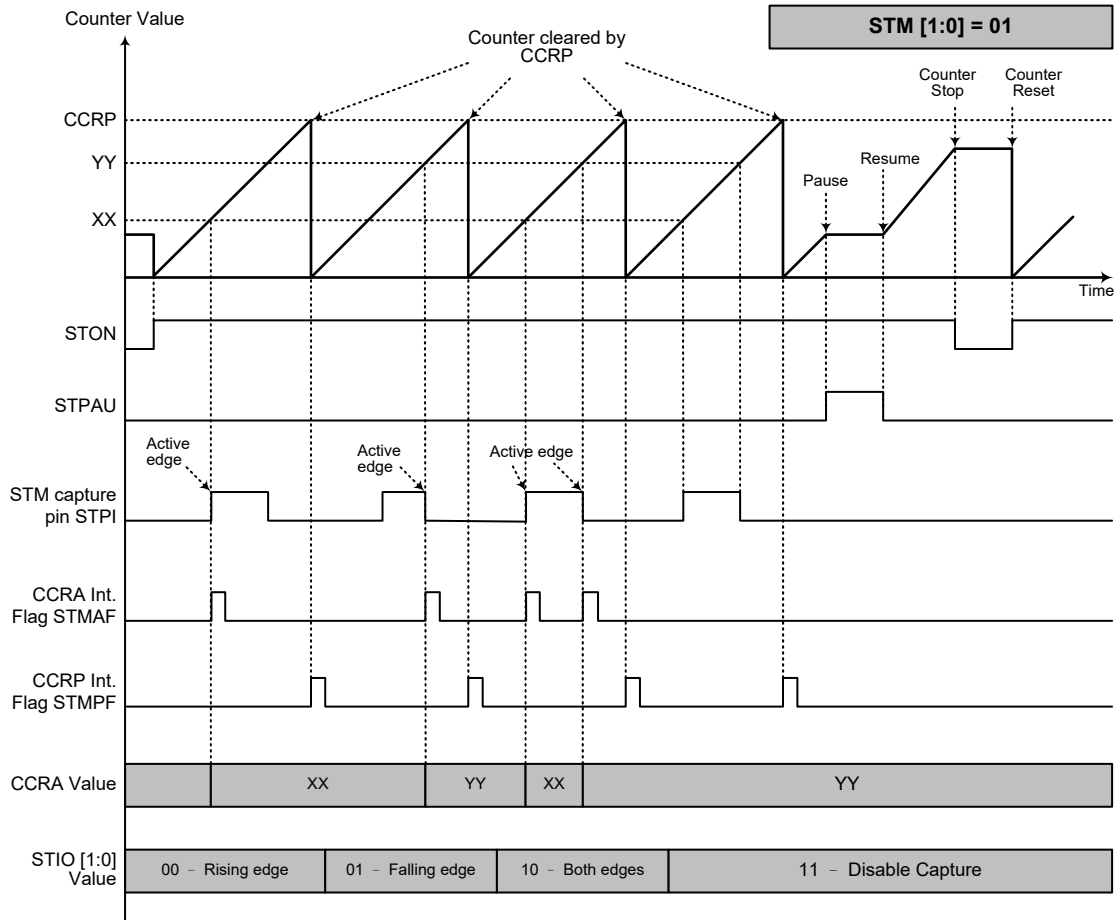

Capture Input Mode

- Note: 1. STM[1:0]=01 and active edge set by the STIO[1:0] bits
 2. A STM Capture input pin active edge transfers the counter value to CCRA
 3. STCCLR bit not used
 4. No output function – STOC and STPOL bits are not used
 5. CCRP determines the counter value and the counter has a maximum count value when CCRP is equal to zero
 6. The capture input mode cannot be used if the selected STM counter clock is not available

Periodic Type TM – PTM

The Periodic Type TM contains four operating modes, which are Compare Match Output, Timer/Event Counter, Single Pulse Output and PWM Output modes. The Periodic TM can also be controlled with one external input pin and can drive two external output pins.

Device	PTM Core	PTM Input Pins	PTM Output Pins
HT67L2540A	16-bit PTM (PTM0)	PTCK0	PTP0, PTP0B
HT67L2550A	16-bit PTM (PTM0, PTM1)	PTCK0; PTCK1	PTP0, PTP0B; PTP1, PTP1B

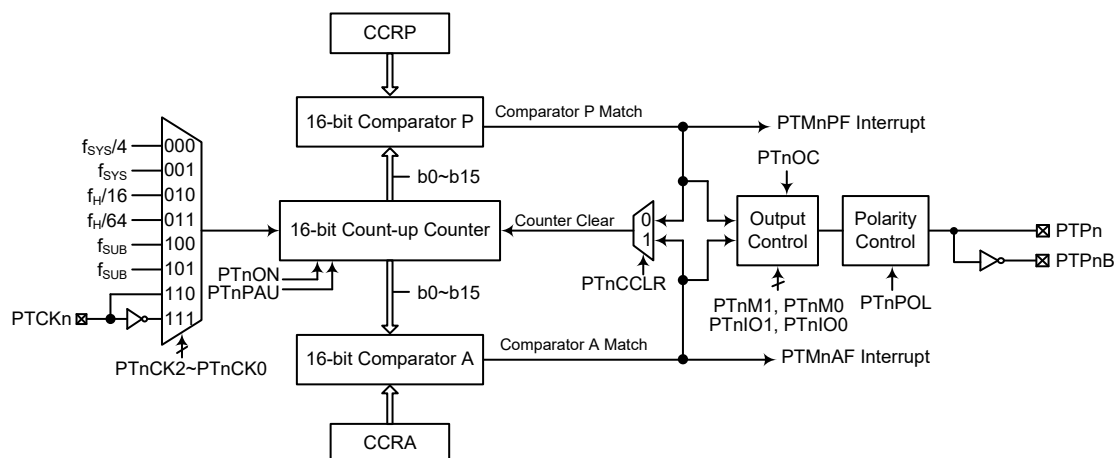

- Note: 1. The PTMn external pins are pin-shared with other functions, so before using the PTMn function, the relevant pin-shared function registers must be set properly to enable the PTMn pin function. The PTCKn pin, if used, must also be set as an input by setting the corresponding bit in the port control register.
2. The PTPnB is the inverted signal of the PTPn.

16-bit Periodic Type TM Block Diagram (n=0~1)

Periodic TM Operation

The size of Periodic Type TM is 16-bit wide and its core is a 16-bit count-up counter which is driven by a user selectable internal or external clock source. There are also two internal comparators with the names, Comparator A and Comparator P. These comparators will compare the value in the counter with CCRP and CCRA registers. The CCRP and CCRA comparators are 16-bit wide whose value is respectively compared with all counter bits.

The only way of changing the value of the 16-bit counter using the application program is to clear the counter by changing the PTnON bit from low to high. The counter will also be cleared automatically by a counter overflow or a compare match with one of its associated comparators. When these conditions occur, a PTMn interrupt signal will also usually be generated. The Periodic Type TM can operate in a number of different operational modes, can be driven by different clock sources including an input pin and can also control two output pins. All operating setup conditions are selected using relevant internal registers.

Periodic TM Register Description

Overall operation of the Periodic TM is controlled using a series of registers. A read only register pair exists to store the internal counter 16-bit value, while two read/write register pairs exist to store the internal 16-bit CCRA and CCRP value. The remaining two registers are control registers which setup the different operating and control modes.

Register Name	Bit							
	7	6	5	4	3	2	1	0
PTMnC0	PTnPAU	PTnCK2	PTnCK1	PTnCK0	PTnON	—	—	—
PTMnC1	PTnM1	PTnM0	PTnIO1	PTnIO0	PTnOC	PTnPOL	D1	PTnCCLR
PTMnDL	D7	D6	D5	D4	D3	D2	D1	D0
PTMnDH	D15	D14	D13	D12	D11	D10	D9	D8
PTMnAL	D7	D6	D5	D4	D3	D2	D1	D0
PTMnAH	D15	D14	D13	D12	D11	D10	D9	D8
PTMnRPL	D7	D6	D5	D4	D3	D2	D1	D0
PTMnRPH	D15	D14	D13	D12	D11	D10	D9	D8

16-bit Periodic TM Register List (n=0~1)

• **PTMnC0 Register**

Bit	7	6	5	4	3	2	1	0
Name	PTnPAU	PTnCK2	PTnCK1	PTnCK0	PTnON	—	—	—
R/W	R/W	R/W	R/W	R/W	R/W	—	—	—
POR	0	0	0	0	0	—	—	—

Bit 7 **PTnPAU**: PTMn Counter Pause control
0: Run
1: Pause

The counter can be paused by setting this bit high. Clearing the bit to zero restores normal counter operation. When in a Pause condition the PTMn will remain powered up and continue to consume power. The counter will retain its residual value when this bit changes from low to high and resume counting from this value when the bit changes to a low value again.

Bit 6~4 **PTnCK2~PTnCK0**: Select PTMn Counter clock
000: $f_{SYS}/4$
001: f_{SYS}
010: $f_H/16$
011: $f_H/64$
100: f_{SUB}
101: f_{SUB}
110: PTCKn rising edge clock
111: PTCKn falling edge clock

These three bits are used to select the clock source for the PTMn. The external pin clock source can be chosen to be active on the rising or falling edge. The clock source f_{SYS} is the system clock, while f_H and f_{SUB} are other internal clocks, the details of which can be found in the oscillator section.

Bit 3 **PTnON**: PTMn Counter On/Off control
0: Off
1: On

This bit controls the overall on/off function of the PTMn. Setting the bit high enables the counter to run while clearing the bit disables the PTMn. Clearing this bit to zero will stop the counter from counting and turn off the PTMn which will reduce its power consumption. When the bit changes state from low to high the internal counter value will be reset to zero, however when the bit changes from high to low, the internal counter will retain its residual value until the bit returns high again.

If the PTMn is in the Compare Match Output Mode, PWM Output Mode or Single Pulse Output Mode then the PTMn output pin will be reset to its initial condition, as specified by the PTnOC bit, when the PTnON bit changes from low to high.

Bit 2~0 Unimplemented, read as “0”

• **PTMnC1 Register**

Bit	7	6	5	4	3	2	1	0
Name	PTnM1	PTnM0	PTnIO1	PTnIO0	PTnOC	PTnPOL	D1	PTnCCLR
R/W	R/W	R/W	R/W	R/W	R/W	R/W	R/W	R/W
POR	0	0	0	0	0	0	0	0

Bit 7~6 **PTnM1~PTnM0**: Select PTMn Operating Mode
 00: Compare Match Output Mode
 01: Undefined
 10: PWM Output Mode or Single Pulse Output Mode
 11: Timer/Counter Mode

These bits setup the required operating mode for the PTMn. To ensure reliable operation the PTMn should be switched off before any changes are made to the PTnM1 and PTnM0 bits. In the Timer/Counter Mode, the PTMn output pin state is undefined.

Bit 5~4 **PTnIO1~PTnIO0**: Select PTMn external pin function

Compare Match Output Mode
 00: No change
 01: Output low
 10: Output high
 11: Toggle output

PWM Output Mode/Single Pulse Output Mode
 00: PWM output inactive state
 01: PWM output active state
 10: PWM output
 11: Single Pulse Output

Timer/Counter Mode
 Unused

These two bits are used to determine how the PTMn external pin changes state when a certain condition is reached. The function that these bits select depends upon in which mode the PTMn is running.

In the Compare Match Output Mode, the PTnIO1 and PTnIO0 bits determine how the PTMn output pin changes state when a compare match occurs from the Comparator A. The PTMn output pin can be setup to switch high, switch low or to toggle its present state when a compare match occurs from the Comparator A. When the bits are both zero, then no change will take place on the output. The initial value of the PTMn output pin should be setup using the PTnOC bit in the PTMnC1 register. Note that the output level requested by the PTnIO1 and PTnIO0 bits must be different from the initial value setup using the PTnOC bit otherwise no change will occur on the PTMn output pin when a compare match occurs. After the PTMn output pin changes state, it can be reset to its initial level by changing the level of the PTnON bit from low to high.

In the PWM output Mode, the PTnIO1 and PTnIO0 bits determine how the TM output pin changes state when a certain compare match condition occurs. The PTMn output function is modified by changing these two bits. It is necessary to change the values of the PTnIO1 and PTnIO0 bits only after the PTMn has been switched off. Unpredictable PWM outputs will occur if the PTnIO1 and PTnIO0 bits are changed when the PTMn is running.

- Bit 3 **PTnOC**: PTMn PTPn Output control
 Compare Match Output Mode
 0: Initial low
 1: Initial high
 PWM Output Mode/Single Pulse Output Mode
 0: Active low
 1: Active high

This is the output control bit for the PTMn output pin. Its operation depends upon whether PTMn is being used in the Compare Match Output Mode or in the PWM Output Mode/Single Pulse Output Mode. It has no effect if the PTMn is in the Timer/Counter Mode. In the Compare Match Output Mode it determines the logic level of the PTMn output pin before a compare match occurs. In the PWM Output Mode it determines if the PWM signal is active high or active low. In the Single Pulse Output Mode it determines the logic level of the PTMn output pin when the PTnON bit changes from low to high.

- Bit 2 **PTnPOL**: PTMn PTPn Output polarity control
 0: Non-inverted
 1: Inverted

This bit controls the polarity of the PTPn output pin. When the bit is set high the PTMn output pin will be inverted and not inverted when the bit is zero. It has no effect if the PTMn is in the Timer/Counter Mode.

- Bit 1 **D1**: Reserved bit, must be fixed at “0”
 Bit 0 **PTnCCLR**: PTMn Counter Clear condition selection
 0: Comparator P match
 1: Comparator A match

This bit is used to select the method which clears the counter. Remember that the Periodic TM contains two comparators, Comparator A and Comparator P, either of which can be selected to clear the internal counter. With the PTnCCLR bit set high, the counter will be cleared when a compare match occurs from the Comparator A. When the bit is low, the counter will be cleared when a compare match occurs from the Comparator P or with a counter overflow. A counter overflow clearing method can only be implemented if the CCRP bits are all cleared to zero. The PTnCCLR bit is not used in the PWM Output or Single Pulse Output Mode.

• **PTMnDL Register**

Bit	7	6	5	4	3	2	1	0
Name	D7	D6	D5	D4	D3	D2	D1	D0
R/W	R	R	R	R	R	R	R	R
POR	0	0	0	0	0	0	0	0

- Bit 7~0 **D7~D0**: PTMn Counter Low Byte Register bit 7 ~ bit 0
 PTMn 16-bit Counter bit 7 ~ bit 0

• **PTMnDH Register**

Bit	7	6	5	4	3	2	1	0
Name	D15	D14	D13	D12	D11	D10	D9	D8
R/W	R	R	R	R	R	R	R	R
POR	0	0	0	0	0	0	0	0

- Bit 7~0 **D15~D8**: PTMn Counter High Byte Register bit 7 ~ bit 0
 PTMn 16-bit Counter bit 15 ~ bit 8

• **PTMnAL Register**

Bit	7	6	5	4	3	2	1	0
Name	D7	D6	D5	D4	D3	D2	D1	D0
R/W	R/W	R/W	R/W	R/W	R/W	R/W	R/W	R/W
POR	0	0	0	0	0	0	0	0

Bit 7~0 **D7~D0**: PTMn CCRA Low Byte Register bit 7 ~ bit 0
PTMn 16-bit CCRA bit 7 ~ bit 0

• **PTMnAH Register**

Bit	7	6	5	4	3	2	1	0
Name	D15	D14	D13	D12	D11	D10	D9	D8
R/W	R/W	R/W	R/W	R/W	R/W	R/W	R/W	R/W
POR	0	0	0	0	0	0	0	0

Bit 7~0 **D15~D8**: PTMn CCRA High Byte Register bit 7 ~ bit 0
PTMn 16-bit CCRA bit 15 ~ bit 8

• **PTMnRPL Register**

Bit	7	6	5	4	3	2	1	0
Name	D7	D6	D5	D4	D3	D2	D1	D0
R/W	R/W	R/W	R/W	R/W	R/W	R/W	R/W	R/W
POR	0	0	0	0	0	0	0	0

Bit 7~0 **D7~D0**: PTMn CCRP Low Byte Register bit 7 ~ bit 0
PTMn 16-bit CCRP bit 7 ~ bit 0

• **PTMnRPH Register**

Bit	7	6	5	4	3	2	1	0
Name	D15	D14	D13	D12	D11	D10	D9	D8
R/W	R/W	R/W	R/W	R/W	R/W	R/W	R/W	R/W
POR	0	0	0	0	0	0	0	0

Bit 7~0 **D15~D8**: PTMn CCRP High Byte Register bit 7 ~ bit 0
PTMn 16-bit CCRP bit 15 ~ bit 8

Periodic Type TM Operation Modes

The Periodic Type TM can operate in one of four operating modes, Compare Match Output Mode, PWM Output Mode, Single Pulse Output Mode or Timer/Counter Mode. The operating mode is selected using the PTnM1 and PTnM0 bits in the PTMnC1 register.

Compare Match Output Mode

To select this mode, bits PTnM1 and PTnM0 in the PTMnC1 register, should be set to 00 respectively. In this mode once the counter is enabled and running it can be cleared by three methods. These are a counter overflow, a compare match from Comparator A and a compare match from Comparator P. When the PTnCCLR bit is low, there are two ways in which the counter can be cleared. One is when a compare match from Comparator P, the other is when the CCRP bits are all zero which allows the counter to overflow. Here both PTMnAF and PTMnPF interrupt request flags for Comparator A and Comparator P respectively, will both be generated.

If the PTnCCLR bit in the PTMnC1 register is high then the counter will be cleared when a compare match occurs from Comparator A. However, here only the PTMnAF interrupt request flag will be generated even if the value of the CCRP bits is less than that of the CCRA registers. Therefore when PTnCCLR is high no PTMnPF interrupt request flag will be generated. In the Compare Match Output Mode, the CCRA can not be set to “0”.

If the CCRA bits are all zero, the counter will overflow when it reaches its maximum 16-bit, FFFF Hex, value, however here the PTMnAF interrupt request flag will not be generated.

As the name of the mode suggests, after a comparison is made, the PTMn output pin will change state. The PTMn output pin condition however only changes state when a PTMnAF interrupt request flag is generated after a compare match occurs from Comparator A. The PTMnPF interrupt request flag, generated from a compare match occurs from Comparator P, will have no effect on the PTMn output pin. The way in which the PTMn output pin changes state are determined by the condition of the PTnIO1 and PTnIO0 bits in the PTMnC1 register. The PTMn output pin can be selected using the PTnIO1 and PTnIO0 bits to go high, to go low or to toggle from its present condition when a compare match occurs from Comparator A. The initial condition of the PTMn output pin, which is setup after the PTnON bit changes from low to high, is setup using the PTnOC bit. Note that if the PTnIO1 and PTnIO0 bits are zero then no pin change will take place.

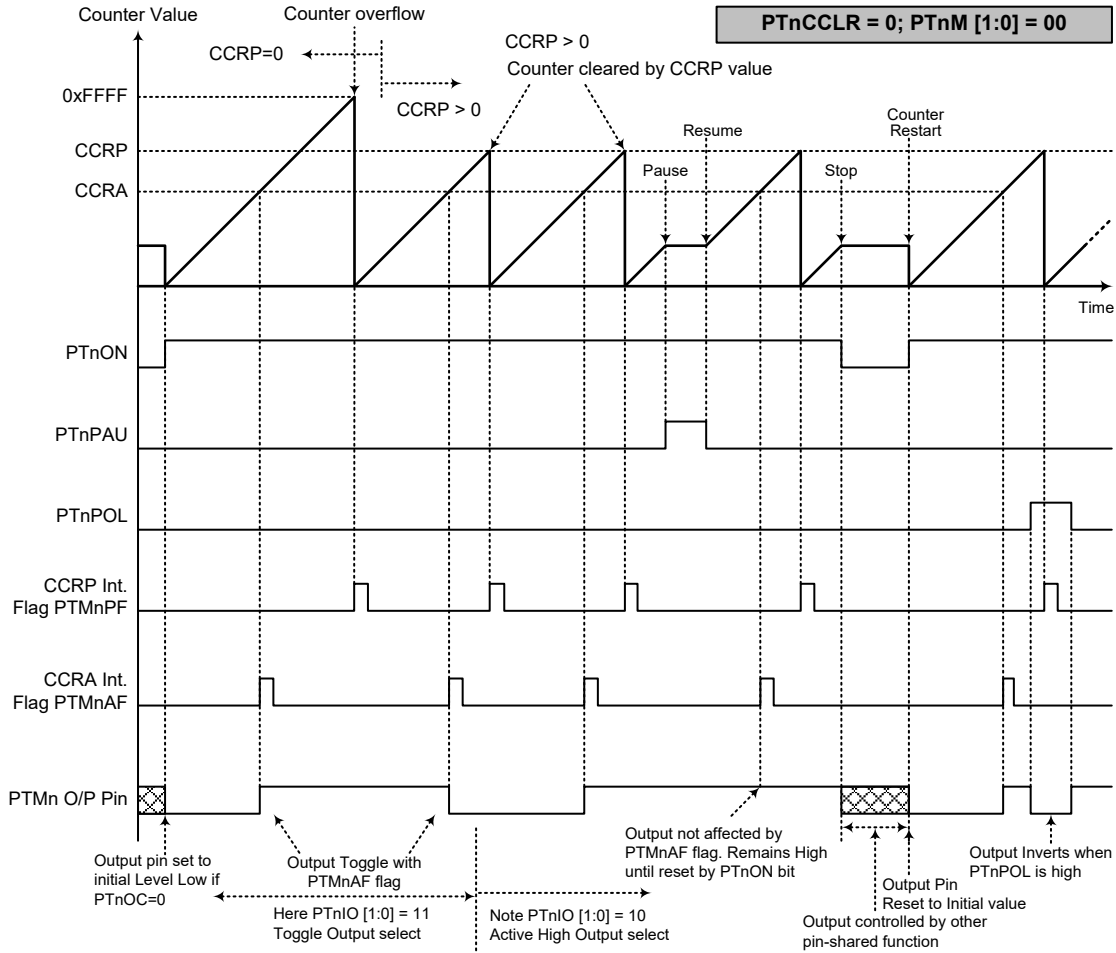

Compare Match Output Mode – PTnCCR=0 (n=0-1)

- Note: 1. With PTnCCR=0, a Comparator P match will clear the counter
 2. The PTMn output pin is controlled only by the PTMnAF flag
 3. The output pin is reset to its initial state by a PTnON bit rising edge

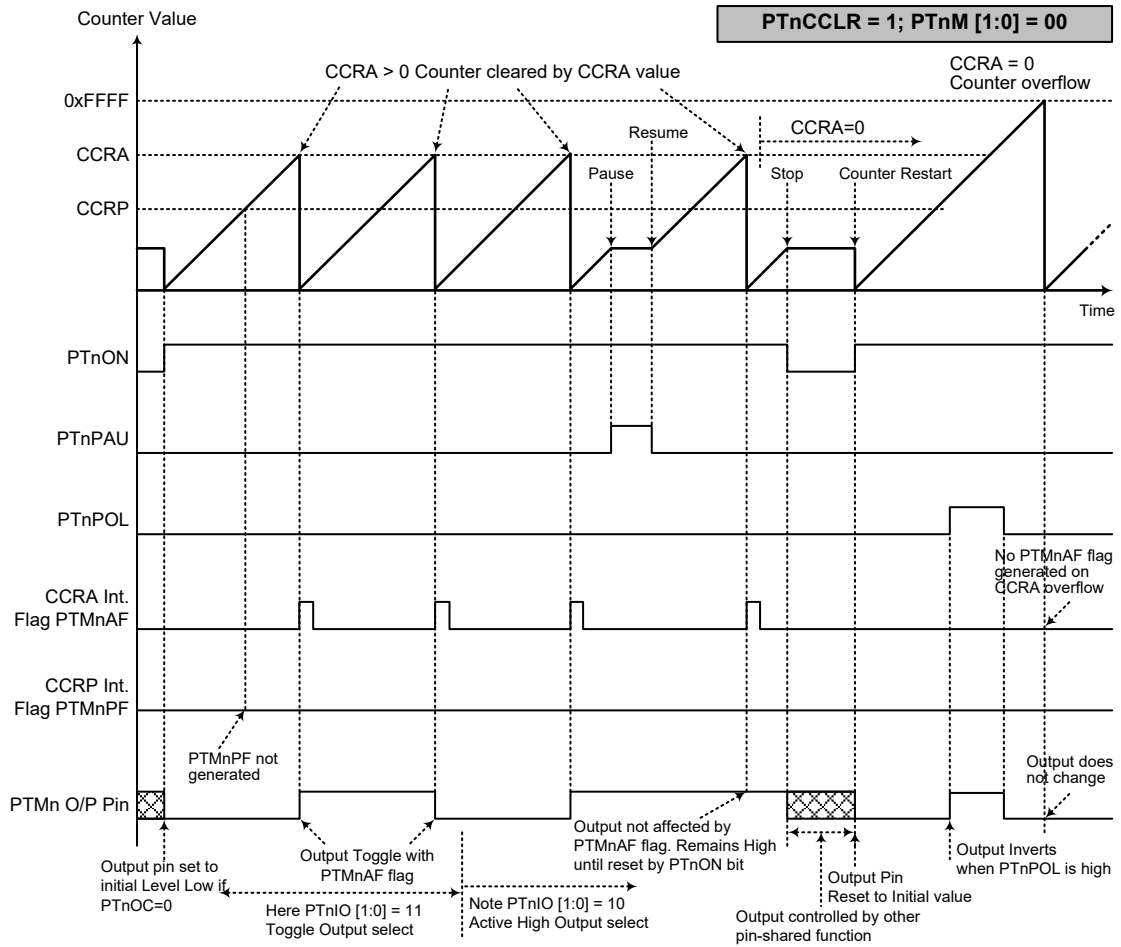

Compare Match Output Mode – PTnCCR=1 (n=0~1)

- Note: 1. With PTnCCR=1, a Comparator A match will clear the counter
2. The PTMn output pin is controlled only by the PTMnAF flag
3. The output pin is reset to its initial state by a PTnON bit rising edge
4. A PTMnPF flag is not generated when PTnCCR=1

Timer/Counter Mode

To select this mode, bits PTnM1 and PTnM0 in the PTMnC1 register should be set to 11 respectively. The Timer/Counter Mode operates in an identical way to the Compare Match Output Mode generating the same interrupt flags. The exception is that in the Timer/Counter Mode the PTMn output pin is not used. Therefore the above description and Timing Diagrams for the Compare Match Output Mode can be used to understand its function. As the PTMn output pin is not used in this mode, the pin can be used as a normal I/O pin or other pin-shared function.

PWM Output Mode

To select this mode, bits PTnM1 and PTnM0 in the PTMnC1 register should be set to 10 respectively and also the PTnIO1 and PTnIO0 bits should be set to 10 respectively. The PWM function within the PTMn is useful for applications which require functions such as motor control, heating control, illumination control, etc. By providing a signal of fixed frequency but of varying duty cycle on the PTMn output pin, a square wave AC waveform can be generated with varying equivalent DC RMS values.

As both the period and duty cycle of the PWM waveform can be controlled, the choice of generated waveform is extremely flexible. In the PWM Output mode, the PTnCCLR bit has no effect as the PWM period. Both of the CCRP and CCRA registers are used to generate the PWM waveform, one register is used to clear the internal counter and thus control the PWM waveform frequency, while the other one is used to control the duty cycle. The PWM waveform frequency and duty cycle can therefore be controlled by the values in the CCRA and CCRP registers.

An interrupt flag, one for each of the CCRA and CCRP, will be generated when a compare match occurs from either Comparator A or Comparator P. The PTnOC bit in the PTMnC1 register is used to select the required polarity of the PWM waveform while the two PTnIO1 and PTnIO0 bits are used to enable the PWM output or to force the PTMn output pin to a fixed high or low level. The PTnPOL bit is used to reverse the polarity of the PWM output waveform.

• **16-bit PTM, PWM Output Mode, Edge-aligned Mode**

CCRP	1~65535	0
Period	1~65535	65536
Duty	CCRA	

If $f_{SYS}=16\text{MHz}$, PTMn clock source select $f_{SYS}/4$, CCRP=512 and CCRA=128,

The PTMn PWM output frequency= $(f_{SYS}/4)/512=f_{SYS}/2048=7.8125\text{kHz}$, duty=128/512=25%,

If the Duty value defined by the CCRA register is equal to or greater than the Period value, then the PWM output duty is 100%.

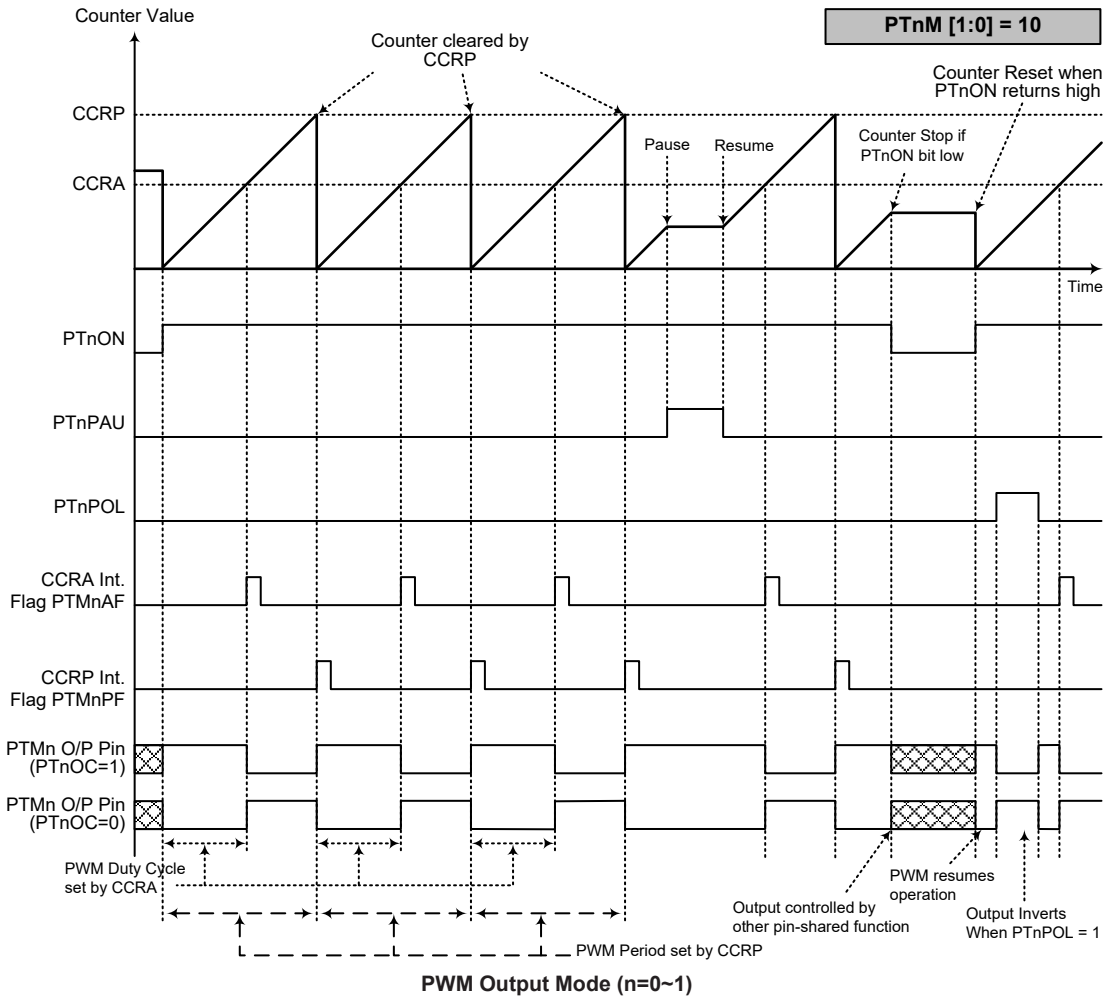

- Note: 1. The counter is cleared by CCRP.
 2. A counter clear sets the PWM Period
 3. The internal PWM function continues running even when PTnIO[1:0]=00 or 01
 4. The PTnCCLR bit has no influence on PWM operation

Single Pulse Output Mode

To select this mode, bits PTnM1 and PTnM0 in the PTMnC1 register should be set to 10 respectively and also the PTnIO1 and PTnIO0 bits should be set to 11 respectively. The Single Pulse Output Mode, as the name suggests, will generate a single shot pulse on the PTMn output pin.

The trigger for the pulse output leading edge is a low to high transition of the PTnON bit, which can be implemented using the application program. However in the Single Pulse Output mode, the PTnON bit can also be made to automatically change from low to high using the external PTCKn pin, which will in turn initiate the Single Pulse output. When the PTnON bit transitions to a high level, the counter will start running and the pulse leading edge will be generated. The PTnON bit should remain high when the pulse is in its active state. The generated pulse trailing edge will be generated when the PTnON bit is cleared to zero, which can be implemented using the application program or when a compare match occurs from Comparator A.

However a compare match from Comparator A will also automatically clear the PTnON bit and thus generate the Single Pulse output trailing edge. In this way the CCRA value can be used to control the pulse width. A compare match from Comparator A will also generate a PTMn interrupt. The counter can only be reset back to zero when the PTnON bit changes from low to high when the counter restarts. In the Single Pulse Output Mode, CCRP is not used. The PTnCCLR bit is not used in this mode.

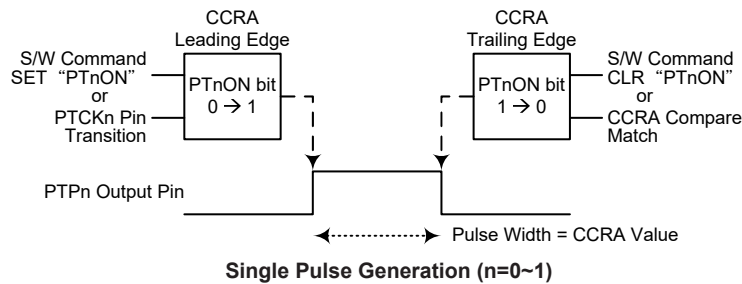

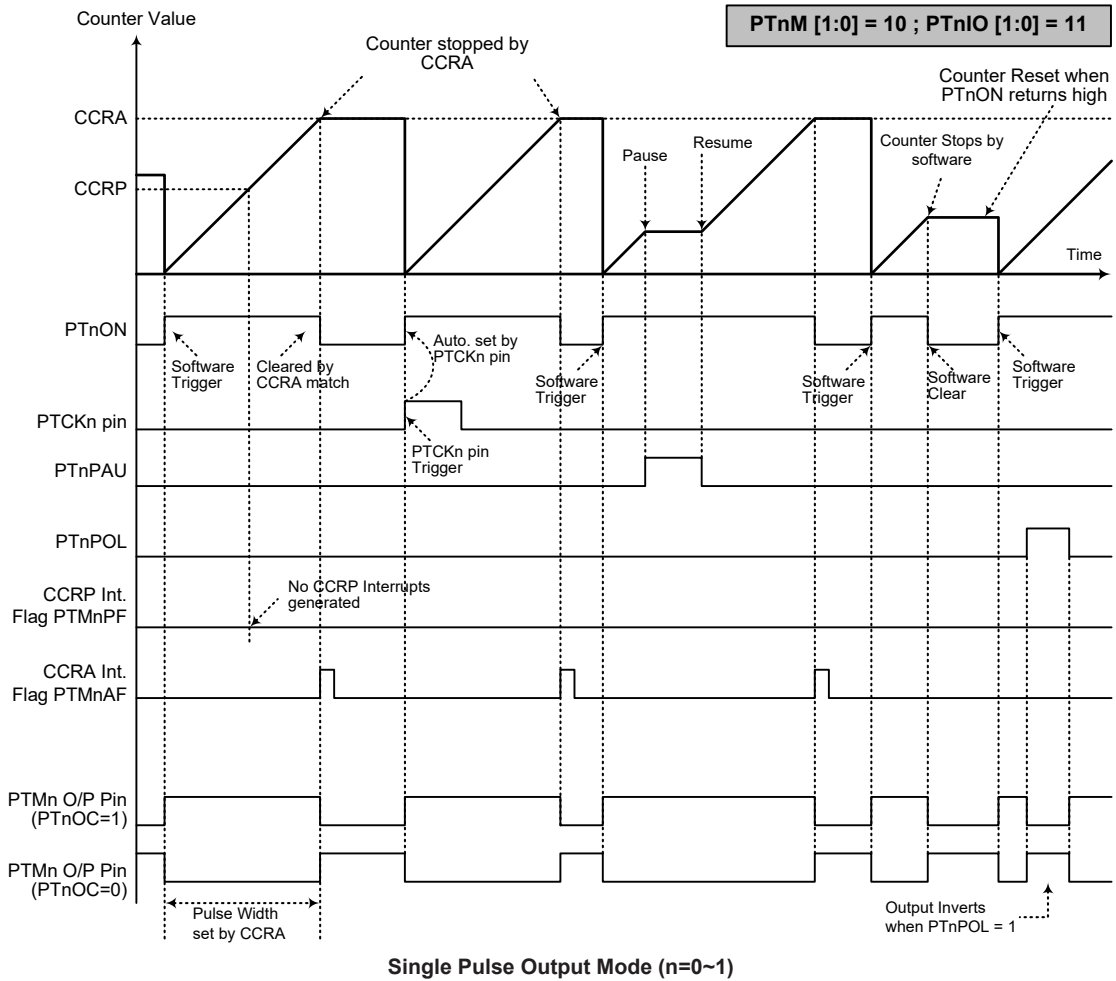

- Note:
1. Counter stopped by CCRA
 2. CCRP is not used
 3. The pulse triggered by the PTCKn pin or by setting the PTnON bit high
 4. A PTCKn pin active edge will automatically set the PTnON bit high
 5. In the Single Pulse Output mode, PTnIO[1:0] must be set to "11" and cannot be changed

Analog to Digital Converter

The need to interface to real world analog signals is a common requirement for many electronic systems. However, to properly process these signals by a microcontroller, they must first be converted into digital signals by A/D converters. By integrating the A/D conversion electronic circuitry into the microcontroller, the need for external components is reduced significantly with the corresponding follow-on benefits of lower costs and reduced component space requirements.

A/D Converter Overview

The devices contain a multi-channel 10/12-bit analog to digital converter which can directly interface to external analog signals, such as that from sensors or other control signals and convert these signals directly into a 10/12-bit digital value. It also can convert the internal signals, such as the bandgap reference voltage V_{BG} into a 10/12-bit digital value. The external or internal analog signal to be converted is determined by the SAINS2~SAINS0 bits together with the SACS3~SACS0 bits. Note that when the internal analog signal is to be converted, the SAINS2~SAINS0 and SACS3~SACS0 bits should be properly configured to avoid external channel input. More detailed information about the A/D input signal is described in the “A/D Converter Control Registers” and “A/D Converter Input Signals” sections respectively.

The 12-bit A/D converter also includes a temperature sensor circuitry which contains a temperature sensor, two operational amplifiers and an internal reference voltage. The temperature sensor can detect the temperature and then output a voltage proportional to the temperature. The output voltage can be amplified by the OPA and then converted to a 12-bit digital data using the A/D converter.

Resolution	External Input Channels	Internal Signals	Channel Select Bits
10-bit	8: AN0~AN7	2: V_{BG} , V_{SS}	SAINS2~SAINS0,
12-bit		3: V_{BG} , V_{SS} , $V_{T_{SO}}$	SACS3~SACS0

The accompanying block diagram shows the overall internal structure of the A/D converter together with its associated registers.

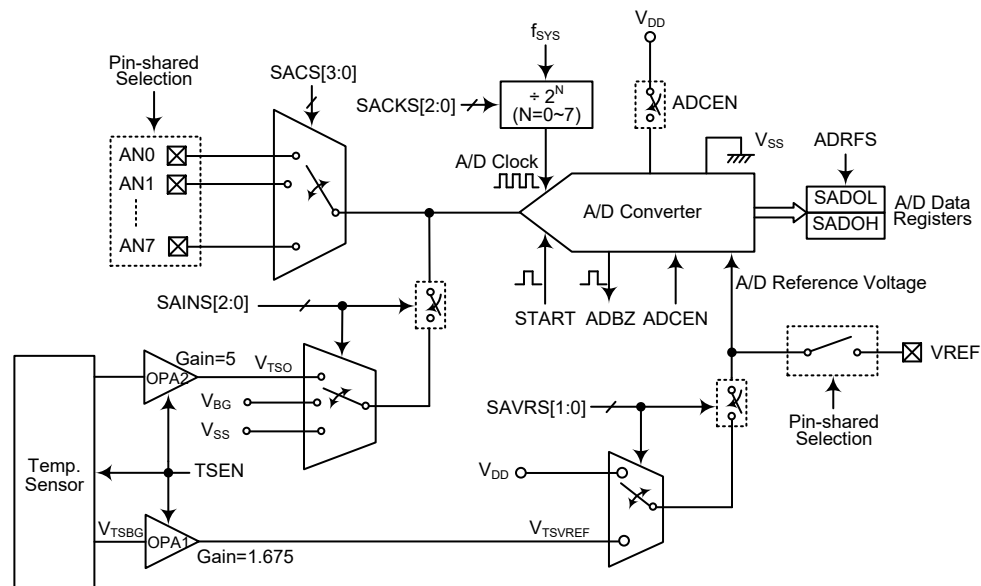

Note: The temperature sensor is only used for the 12-bit resolution mode, with the A/D converter clock rate of up to 2MHz being selected (SABMS=0, SACMS[1:0]=00).

A/D Converter Structure

A/D Converter Register Description

Overall operation of the A/D converter is controlled using several registers. A read only register pair exists to store the A/D converter data 10/12-bit value. Three registers, SADC0, SADC1 and SADC2, are control registers which setup the operating and control function of the A/D converter.

Register Name	Bit							
	7	6	5	4	3	2	1	0
SAD0H (SABMS=0, ADRFS=0)	D11	D10	D9	D8	D7	D6	D5	D4
SAD0H (SABMS=0, ADRFS=1)	—	—	—	—	D11	D10	D9	D8
SAD0H (SABMS=1, ADRFS=0)	D9	D8	D7	D6	D5	D4	D3	D2
SAD0H (SABMS=1, ADRFS=1)	—	—	—	—	—	—	D9	D8
SAD0L (SABMS=0, ADRFS=0)	D3	D2	D1	D0	—	—	—	—
SAD0L (SABMS=0, ADRFS=1)	D7	D6	D5	D4	D3	D2	D1	D0
SAD0L (SABMS=1, ADRFS=0)	D1	D0	—	—	—	—	—	—
SAD0L (SABMS=1, ADRFS=1)	D7	D6	D5	D4	D3	D2	D1	D0
SADC0	START	ADBZ	ADCEN	ADRFS	SACS3	SACS2	SACS1	SACS0
SADC1	SAINS2	SAINS1	SAINS0	SAVRS1	SAVRS0	SACKS2	SACKS1	SACKS0
SADC2	SACMS1	SACMS0	SABMS	—	—	—	D1	TSEN

A/D Converter Register List

A/D Converter Data Registers – SADOL, SAD0H

As each device contains an internal 10/12-bit A/D converter, it requires two data registers to store the converted value. These are a high byte register, known as SAD0H, and a low byte register, known as SADOL. After the conversion process takes place, these registers can be directly read by the microcontroller to obtain the digitised conversion value. As only 10/12 bits of the 16-bit register space is utilised, the format in which the data is stored is controlled by the ADRFS bit in the SADC0 register together with the SABMS bit in the SADC2 register as shown in the accompanying table. D0~D11 are the A/D conversion result data bits. Any unused bits will be read as zero. Note that A/D Converter data register contents will be unchanged if the A/D converter is disabled.

SABMS	ADRFS	SAD0H								SADOL							
		7	6	5	4	3	2	1	0	7	6	5	4	3	2	1	0
0	0	D11	D10	D9	D8	D7	D6	D5	D4	D3	D2	D1	D0	0	0	0	0
0	1	0	0	0	0	D11	D10	D9	D8	D7	D6	D5	D4	D3	D2	D1	D0
1	0	D9	D8	D7	D6	D5	D4	D3	D2	D1	D0	0	0	0	0	0	0
1	1	0	0	0	0	0	0	D9	D8	D7	D6	D5	D4	D3	D2	D1	D0

A/D Converter Data Registers

A/D Converter Control Registers – SADC0, SADC1, SADC2

To control the function and operation of the A/D converter, three control registers known as SADC0, SADC1 and SADC2 are provided. These 8-bit registers define functions such as the selection of which analog channel is connected to the internal A/D converter, the digitised data format, the A/D clock source as well as controlling the start function and monitoring the A/D converter busy status.

As the device contains only one actual analog to digital converter hardware circuit, each of the external or internal analog signal inputs must be routed to the converter. The SACS3~SACS0 bits in the SADC0 register are used to determine which external channel input is selected to be converted. The SAINS2~SAINS0 bits in the SADC1 register are used to determine that the analog signal to be converted comes from the internal analog signal or external analog channel input. The SADC2 register is used to enable/disable the integrated temperature sensor circuitry, select the A/D converter conversion mode and A/D converter resolution selection.

The relevant pin-shared function selection bits determine which pins on I/O Ports are used as analog inputs for the A/D converter input and which pins are not to be used as the A/D converter input. When the pin is selected to be an A/D input, its original function whether it is an I/O or other pin-shared function will be removed. In addition, any internal pull-high resistor connected to the pin will be automatically removed if the pin is selected to be an A/D converter input.

• **SADC0 Register**

Bit	7	6	5	4	3	2	1	0
Name	START	ADBZ	ADCEN	ADRFS	SACS3	SACS2	SACS1	SACS0
R/W	R/W	R	R/W	R/W	R/W	R/W	R/W	R/W
POR	0	0	0	0	0	0	0	0

- Bit 7 START:** Start the A/D conversion
 0→1→0: Start
 This bit is used to initiate an A/D conversion process. The bit is normally low but if set high and then cleared low again, the A/D converter will initiate a conversion process.
- Bit 6 ADBZ:** A/D converter busy flag
 0: No A/D conversion is in progress
 1: A/D conversion is in progress
 This read only flag is used to indicate whether the A/D conversion is in progress or not. When the START bit is set from low to high and then to low again, the ADBZ flag will be set to 1 to indicate that the A/D conversion is initiated. The ADBZ flag will be cleared to 0 after the A/D conversion is complete.
- Bit 5 ADCEN:** A/D converter function enable control
 0: Disable
 1: Enable
 This bit controls the A/D internal function. This bit should be set to one to enable the A/D converter. If the bit is set low, then the A/D converter will be switched off reducing the device power consumption. When the A/D converter function is disabled, the contents of the A/D data register pair known as SADOH and SADOL will be unchanged.
- Bit 4 ADRFS:** A/D converter data format selection
 12-bit resolution mode
 0: A/D converter data format → SADOH = D[11:4]; SADOL = D[3:0]
 1: A/D converter data format → SADOH = D[11:8]; SADOL = D[7:0]
 10-bit resolution mode
 0: A/D converter data format → SADOH = D[9:2]; SADOL = D[1:0]
 1: A/D converter data format → SADOH = D[9:8]; SADOL = D[7:0]
 This bit controls the format of the 10/12-bit converted A/D value in the two A/D data registers. Details are provided in the A/D converter data register section.
- Bit 3~0 SACS3~SACS0:** A/D converter external analog channel input selection
 0000: AN0
 0001: AN1
 0010: AN2
 0011: AN3
 0100: AN4

0101: AN5
 0110: AN6
 0111: AN7
 1000~1111: Non-existed channel, the input will be floating

• **SADC1 Register**

Bit	7	6	5	4	3	2	1	0
Name	SAINS2	SAINS1	SAINS0	SAVRS1	SAVRS0	SACKS2	SACKS1	SACKS0
R/W	R/W	R/W	R/W	R/W	R/W	R/W	R/W	R/W
POR	0	0	0	0	0	0	0	0

Bit 7~5 **SAINS2~SAINS0**: A/D converter input signal selection
 000: External input – External analog channel input
 001: Internal input – Bandgap reference voltage, V_{BG}
 010: Internal input – Internal temperature Sensor output voltage, $V_{T_{SO}}$
 011: Internal input – Ground, V_{SS}
 100: Internal input – Ground, V_{SS}
 101: External input – External analog channel input
 110: External input – External analog channel input
 111: Forbidden data, SAINS2~SAINS0 bits can not be written with “111”

Note that SAINS2~SAINS0 bits can only be set to “010” for the 12-bit resolution mode.

Care must be taken if the SAINS2~SAINS0 bits are set from “001~100” to select the internal analog signal to be converted. When the internal analog signal is selected to be converted, the external input pin must never be selected as the A/D input signal by properly setting the SACS3~SACS0 bits. Otherwise, the external channel input will be connected together with the internal analog signal. This will result in unpredictable situations such as an irreversible damage.

Bit 4~3 **SAVRS1~SAVRS0**: A/D converter reference voltage selection
 00: From external VREF pin
 01: Internal A/D converter power, V_{DD}
 10: Internal temperature sensor reference voltage, $V_{T_{SVREF}}$
 11: Internal A/D converter power, V_{DD}

Note that SAVRS1~SAVRS0 bits can only be set to “10” for the 12-bit resolution mode.

These bits are used to select the A/D converter reference voltage. Care must be taken if the SAVRS1~SAVRS0 bits are set to “01~11” to select the internal A/D converter power or temperature sensor reference voltage as the reference voltage source. When the internal A/D converter power or temperature sensor reference voltage is selected as the reference voltage, the VREF pin cannot be configured as the reference voltage input by properly configuring the corresponding pin-shared function control bits. Otherwise, the external input voltage on VREF pin will be connected to the internal reference signal.

Bit 2~0 **SACKS2~SACKS0**: A/D conversion clock source select
 000: f_{SYS}
 001: $f_{SYS}/2$
 010: $f_{SYS}/4$
 011: $f_{SYS}/8$
 100: $f_{SYS}/16$
 101: $f_{SYS}/32$
 110: $f_{SYS}/64$
 111: $f_{SYS}/128$

These three bits are used to select the clock source for the A/D converter. These bits should be properly configured according to the A/D conversion mode selected by SACMS[1:0] bits in the SADC2 register, to implement the desired clock rate.

• **SADC2 Register**

Bit	7	6	5	4	3	2	1	0
Name	SACMS1	SACMS0	SABMS	—	—	—	D1	TSEN
R/W	R/W	R/W	R/W	—	—	—	R/W	R/W
POR	0	0	0	—	—	—	1	0

Bit 7~6 **SACMS1~SACMS0**: A/D converter conversion mode selection
 00: A/D converter clock rate is up to 2MHz
 01: A/D converter clock rate is up to 1MHz
 10: A/D converter clock rate is up to 500kHz
 11: A/D converter clock rate is limited to 100kHz~250kHz (low current mode)
 These bits are used to select the A/D converter conversion mode. The low current mode is suitable for continuous static signal conversion.

Bit 5 **SABMS**: 10/12-bit A/D converter resolution selection
 0: 12-bit
 1: 10-bit

Bit 4~2 Unimplemented, read as “0”

Bit 1 **D1**: Reserved bit, must be fixed at 1

Bit 0 **TSEN**: Temperature sensor circuitry enable control
 0: Disable
 1: Enable

This bit controls the internal temperature sensor circuitry. If the temperature sensor output will be converted or the temperature sensor reference voltage will be selected as the A/D conversion reference voltage, the temperature sensor circuitry should be turned on by setting the TSEN bit high first. When the temperature sensor is enabled by setting the TSEN bit to 1, a time named as t_{TSS} should be allowed for the temperature sensor circuit to stabilise before implementing relevant temperature sensor operation.

The temperature sensor is only used for the 12-bit resolution mode, with the A/D converter clock rate of up to 2MHz being selected (SABMS=0, SACMS[1:0]=00).

A/D Converter Operation

The START bit in the SADC0 register is used to start the AD conversion. When the microcontroller sets this bit from low to high and then low again, an analog to digital conversion cycle will be initiated.

The ADBZ bit in the SADC0 register is used to indicate whether the analog to digital conversion process is in progress or not. This bit will be automatically set to 1 by the microcontroller after an A/D conversion is successfully initiated. When the A/D conversion is complete, the ADBZ will be cleared to 0. In addition, the corresponding A/D interrupt request flag will be set in the interrupt control register, and if the interrupts are enabled, an appropriate internal interrupt signal will be generated. This A/D internal interrupt signal will direct the program flow to the associated A/D internal interrupt address for processing. If the A/D internal interrupt is disabled, the microcontroller can poll the ADBZ bit in the SADC0 register to check whether it has been cleared as an alternative method of detecting the end of an A/D conversion cycle.

The A/D converter supports different conversion modes, where the A/D clock rate is up to 2MHz, 1MHz or 500kHz, or in a limited range of 100kHz~250kHz (low current mode), selected by the SACMS[1:0] bits in the SADC2 register. The low current mode is suitable for continuous static signal conversion.

The clock source for the A/D converter, which originates from the system clock f_{SYS} , can be chosen to be either f_{SYS} or a subdivided version of f_{SYS} . The division ratio value is determined by the SACKS2~SACKS0 bits in the SADC1 register. Although the A/D clock source is determined by

the system clock f_{SYS} and by bits SACKS2~SACKS0, there are some limitations on the maximum A/D clock source speed that can be selected. As the recommended range of permissible A/D clock period, t_{ADCK} , is from $0.5\mu s$ to $10\mu s$, care must be taken for system clock frequencies. For example, as the system clock operates at a frequency of 8MHz, the SACKS2~SACKS0 bits should not be set to 000, 001 or 111. Doing so will give A/D clock periods that are less or larger than the minimum or maximum A/D clock period which may result in inaccurate A/D conversion values. Refer to the following table for examples, where values marked with an asterisk * show where special care must be taken, as the values may be less or larger than the specified A/D Clock Period range.

For the 12-bit resolution mode if the input signal to be converted is the temperature sensor output voltage, the SACMS[1:0] bits should be set to “00”, i.g., the permissible A/D clock period is from $1\mu s$ to $2\mu s$.

f_{SYS}	A/D Clock Period (t_{ADCK})							
	SACKS[2:0] = 000 (f_{SYS})	SACKS[2:0] = 001 ($f_{SYS}/2$)	SACKS[2:0] = 010 ($f_{SYS}/4$)	SACKS[2:0] = 011 ($f_{SYS}/8$)	SACKS[2:0] = 100 ($f_{SYS}/16$)	SACKS[2:0] = 101 ($f_{SYS}/32$)	SACKS[2:0] = 110 ($f_{SYS}/64$)	SACKS[2:0] = 111 ($f_{SYS}/128$)
1MHz	$1\mu s$	$2\mu s$	$4\mu s$	$8\mu s$	$16\mu s$ *	$32\mu s$ *	$64\mu s$ *	$128\mu s$ *
2MHz	500ns	$1\mu s$	$2\mu s$	$4\mu s$	$8\mu s$	$16\mu s$ *	$32\mu s$ *	$64\mu s$ *
4MHz	250ns *	500ns	$1\mu s$	$2\mu s$	$4\mu s$	$8\mu s$	$16\mu s$ *	$32\mu s$ *
8MHz	125ns *	250ns *	500ns	$1\mu s$	$2\mu s$	$4\mu s$	$8\mu s$	$16\mu s$ *
12MHz	83ns *	167ns *	333ns *	667ns *	1.33 μs	2.67 μs	5.33 μs	10.67 μs *
16MHz	62.5ns *	125ns *	250ns *	500ns	$1\mu s$	$2\mu s$	$4\mu s$	$8\mu s$

A/D Clock Period Examples

Controlling the power on/off function of the A/D converter circuitry is implemented using the ADCEN bit in the SADC0 register. This bit must be set high to power on the A/D converter. When the ADCEN bit is set high to power on the A/D converter internal circuitry a certain delay, as indicated in the timing diagram, must be allowed before an A/D conversion is initiated. Even if no pins are selected for use as A/D inputs, if the ADCEN bit is high, then some power will still be consumed. In power conscious applications it is therefore recommended that the ADCEN is set low to reduce power consumption when the A/D converter function is not being used.

A/D Converter Reference Voltage

The reference voltage supply to the A/D converter can be supplied from the power supply V_{DD} , or from the temperature sensor reference voltage, V_{TSVREF} , or from an external reference source supplied on pin VREF. The desired selection is made using the SAVRS1~SAVRS0 bits. When the SAVRS1~SAVRS0 bits are set to “01” or “11”, the A/D converter reference voltage will come from the V_{DD} . If the temperature sensor reference voltage is required to use, the SAVRS1~SAVRS0 bits should be set to “10”. As the temperature sensor circuitry is controlled by the TSEN bit in the SADC2 register, the TSEN bit should be set high to enable the temperature sensor. Otherwise, if the SAVRS1~SAVRS0 bits are set to “00”, the A/D converter reference voltage will come from the VREF pin. As the VREF pin is pin-shared with other functions, when the VREF pin is selected as the reference voltage supply pin, the VREF pin-shared function control bit should be properly configured to disable other pin function. However, if the internal A/D converter power V_{DD} or temperature sensor reference voltage is selected as the reference voltage, the VREF pin must not be configured as the reference voltage input function to avoid the internal connection between the VREF pin and the power supply. The analog input values must not be allowed to exceed the value of the selected A/D reference voltage.

Note that the temperature sensor is only used for the 12-bit resolution mode, with the A/D converter clock rate of up to 2MHz being selected (SABMS=0, SACMS[1:0]=00).

SAVRS[1:0]	Reference	Description
00	VREF pin	External A/D converter reference pin VREF
01, 11	V _{DD}	Internal A/D converter power supply voltage
10	V _{TSVREF}	Internal Temperature Sensor reference voltage

A/D Converter Reference Voltage Selection

A/D Converter Input Signals

All the external A/D analog channel input pins are pin-shared with the I/O pins as well as other functions. The corresponding control bits for each A/D external input pin in the PxS0 and PxS1 registers determine whether the input pins are setup as A/D converter analog input channel or whether they have other functions. If the pin is setup to be as an A/D analog channel input, the original pin functions will be disabled. In this way, pins can be changed under program control to change their function between A/D inputs and other functions. All pull-high resistors, which are setup through register programming, will be automatically disconnected if the pins are setup as A/D inputs. Note that it is not necessary to first setup the A/D pin as an input in the port control register to enable the A/D input as when the pin-shared function control bits enable an A/D input, the status of the port control register will be overridden.

There are some internal analog signals derived from the bandgap reference voltage, V_{BG}, or the temperature sensor output voltage which can be connected to the A/D converter as the analog input signal by configuring the SAINS2~SAINS0 bits. If the external channel input is selected to be converted, the SAINS2~SAINS0 bits should be set to “000” or “101~110” and the SACS3~SACS0 bits can determine which external channel is selected. If the internal analog signal is selected to be converted, the external input channel determined by the SACS3~SACS0 bits must be switched to a non-existent A/D input channel by properly setting the SACS3~SACS0 bits with a value from 1000 to 1111. Otherwise, the internal analog signal will be connected together with the external channel input. This will result in unpredictable situations.

Note that the temperature sensor is only used for the 12-bit resolution mode, with the A/D converter clock rate of up to 2MHz being selected (SABMS=0, SACMS[1:0]=00).

SAINS[2:0]	SACS[3:0]	Input Signals	Description
000, 101, 110	0000~0111	AN0~AN7	External pin analog input
	1000~1111	—	Non-existent channel, input is floating
001	1000~1111	V _{BG}	Bandgap reference voltage
010	1000~1111	V _{TSS}	Internal temperature sensor output voltage
011, 100	1000~1111	V _{SS}	Connected to ground
111	Forbidden data, SAINS2~SAINS0 bits can not be written with “111”		

A/D Converter Input Signal Selection

Conversion Rate and Timing Diagram

For the 12-bit resolution mode, a complete A/D conversion contains two parts, data sampling and data conversion. If the conversion input signal is not the temperature sensor output, the data sampling which is defined as t_{ADS} takes 4 A/D clock periods and the data conversion takes 12 A/D clock periods. Therefore a total of 16 A/D clock periods for an A/D conversion which is defined as t_{ADC} are necessary. However, an A/D conversion for an internal temperature sensor signal will take a total of 58 A/D clock periods, which includes 46 A/D clock periods for data sampling and 12 A/D clock periods for data conversion.

Maximum single A/D conversion rate = 1/(A/D clock period × 16) (Temperature sensor output signal is not used)

Maximum single A/D conversion rate = $1/(\text{A/D clock period} \times 58)$ (Temperature sensor output signal is used)

For the 10-bit resolution mode, a complete A/D conversion contains two parts, data sampling and data conversion. If an A/D conversion for the low current mode, the data sampling which is defined as t_{ADS} takes 2 A/D clock periods and the data conversion takes 10 A/D clock periods. Therefore a total of 12 A/D clock periods for an A/D conversion which is defined as t_{ADC} are necessary. However, an A/D conversion for other conversion modes will take a total of 13 A/D clock periods, which includes 3 A/D clock periods for data sampling and 10 A/D clock periods for data conversion.

Maximum single A/D conversion rate = $1/(\text{A/D clock period} \times 12)$ (Low current mode)

Maximum single A/D conversion rate = $1/(\text{A/D clock period} \times 13)$ (Not low current mode)

The accompanying diagram shows graphically the various stages involved in an analog to digital conversion process and its associated timing. After an A/D conversion process has been initiated by the application program, the microcontroller internal hardware will begin to carry out the conversion, during which time the program can continue with other functions.

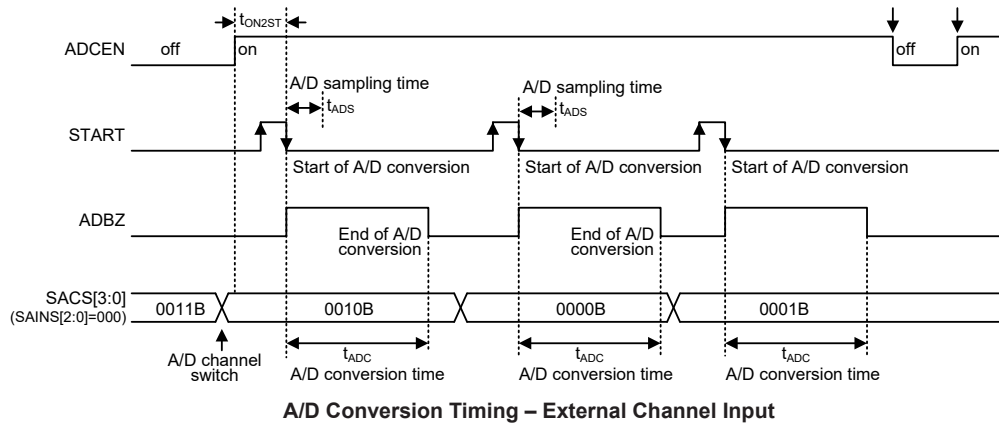

Summary of A/D Conversion Steps

The following summarises the individual steps that should be executed in order to implement an A/D conversion process.

- Step 1
Select the required A/D conversion clock, resolution and A/D conversion mode by correctly programming bits SACKS2~SACKS0 in the SADC1 register, SABMS and SACMS1~SACMS0 bits in the SADC2 register.
- Step 2
Enable the A/D converter by setting the ADCEN bit in the SADC0 register to 1.
- Step 3
Select which signal is to be connected to the internal A/D converter by correctly configuring the SAINS2~SAINS0 bits in the SADC1 register.
Select the external channel input to be converted, go to Step 4.
Select the internal analog signal to be converted, go to Step 5.
- Step 4
If the A/D input signal comes from the external channel input selected by configuring the SAINS2~SAINS0 bits, the corresponding pins should be configured as A/D input function by configuring the relevant pin-shared function control bits. The desired analog channel then should be selected by configuring the SACS3~SACS0 bits. After this step, go to Step 6.

- Step 5
Before the A/D input signal is selected to come from the internal analog signal by configuring the SAINS2~SAINS0 bits, the corresponding external input pin must be switched to a non-existent channel input by properly configured the SACS3~SACS0 bits. The desired internal analog signal then can be selected by configuring the SAINS2~SAINS0 bits. After this step, go to Step 6.
- Step 6
Select the reference voltage source by configuring the SAVRS1~SAVRS0 bits in the SADC1 register. Care should be taken in this step which can refer to the A/D Converter Reference Voltage section for details.
- Step 7
Select A/D converter output data format by setting the ADRFS bit in the SADC0 register.
- Step 8
If A/D conversion interrupt is used, the interrupt control registers must be correctly configured to ensure the A/D interrupt function is active. The master interrupt control bit, EMI, and the A/D conversion interrupt control bit, ADE, must both be set high in advance.
- Step 9
The A/D conversion procedure can now be initialized by setting the START bit from low to high and then low again.
- Step 10
If A/D conversion is in progress, the ADBZ flag will be set high. After the A/D conversion process is complete, the ADBZ flag will go low and then the output data can be read from SADOH and SADOL registers.

Note: When checking for the end of the conversion process, if the method of polling the ADBZ bit in the SADC0 register is used, the interrupt enable step above can be omitted.

Programming Considerations

During microcontroller operations where the A/D converter is not being used, the A/D internal circuitry can be switched off to reduce power consumption, by clearing bit ADCEN to 0 in the SADC0 register. When this happens, the internal A/D converter circuits will not consume power irrespective of what analog voltage is applied to their input lines. If the A/D converter input lines are used as normal I/O pins, then care must be taken as if the input voltage is not at a valid logic level, then this may lead to some increase in power consumption.

A/D Conversion Function

As the devices contain a 10/12-bit A/D converter, its full-scale converted digitised value is equal to 3FFH/FFFH. Since the full-scale analog input value is equal to the actual A/D converter reference voltage, V_{REF} , this gives a single bit analog input value of V_{REF} divided by 1024 or 4096.

$$1 \text{ LSB} = V_{REF} \div 1024 \text{ (10-bit resolution mode)}$$

$$1 \text{ LSB} = V_{REF} \div 4096 \text{ (12-bit resolution mode)}$$

The A/D Converter input voltage value can be calculated using the following equation:

$$\text{A/D input voltage} = \text{A/D output digital value} \times (V_{REF} \div 1024) \text{ (10-bit resolution mode)}$$

$$\text{A/D input voltage} = \text{A/D output digital value} \times (V_{REF} \div 4096) \text{ (12-bit resolution mode)}$$

The diagrams show the ideal transfer function between the analog input value and the digitised output value for the A/D converter. Except for the digitised zero value, the subsequent digitised values will change at a point 0.5 LSB below where they would change without the offset, and the last full scale digitised value will change at a point 1.5 LSB below the V_{REF} level.

Note that here the V_{REF} voltage is the actual A/D converter reference voltage determined by the SAVRS1~SAVRS0 bits.

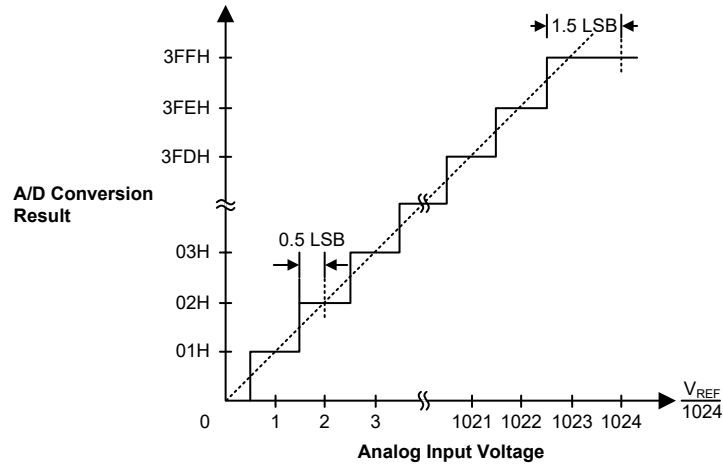

Ideal 10-bit A/D Conversion Function

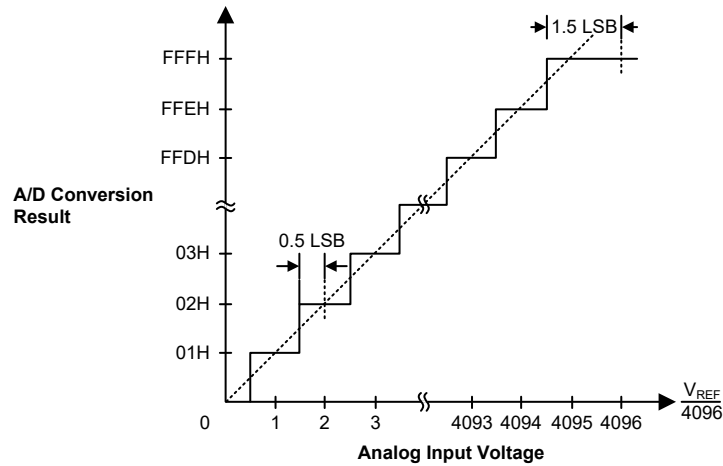

Ideal 12-bit A/D Conversion Function

Temperature Measurement Function (For 12-bit Resolution Mode)

As the temperature sensor output voltage, $V_{T_{SO}}$, has a linear relationship with temperature, the A/D converted data value of $V_{T_{SO}}$ will also have a linear relationship with temperature. The current temperature T_x can be proportionally calculated from its A/D converted value ADC_x using the following formula.

$$T_x = \text{Remove LSB 12 bits of } (\text{Slope} \times ADC_x) - T_{OS}; \text{ take lower 12 bits of the final result}$$

The Slope and T_{OS} code are stored in the Option Memory and can be read from the Program Memory last page using the table read instruction when the Option Memory mapping function is enabled.

At the end of every conversion or say MCU calculation, the final data T_x which is in two's complement format, has a data width of 12 bits and a resolution of 0.0625 ($1/16$) $^{\circ}\text{C}$. The following table shows multiple examples of binary or hex data that can be read as temperature result.

Temperature	Digital Format (1 LSB=1/16=0.0625°C)	
Tx(°C)	BINARY	HEX
-40	1101 1000 0000	D80
-25	1110 0111 0000	E70
-10	1111 0110 0000	F60
-1	1111 1111 0000	FF0
-0.25	1111 1111 1100	FFC
-0.0625	1111 1111 1111	FFF
0	0000 0000 0000	000
0.0625	0000 0000 0001	001
0.25	0000 0000 0100	004
1	0000 0001 0000	010
10	0000 1010 0000	0A0
25	0001 1001 0000	190
40	0010 1000 0000	280
70	0100 0110 0000	460
85	0101 0101 0000	550

For example:

- Step 1
Read the Option Memory, Slope=0x0AB9, T_{OS}=0x407.
- Step 2
Enable temperature sensor and A/D function, then start A/D conversion and read back A/D data registers.
- Step 3
If ADCx=0x514, Slope × ADCx=0x367374. Then remove the lower 12 bits, get 0x0367.
- Step 4
Minus T_{OS}, the result is 0x0367-0x407=FF60H (2's complement). Take the lower 12 bits, then Tx=F60H=-10.0°C.

Name	Mapped Address in Program Memory	Description
Slope	FF5H	16-bit Slope value bit 15~bit 8
	FF6H	16-bit Slope value bit 7~bit 0
T _{OS}	FE6H	12-bit T _{OS} value bit 11~bit 4
	FE7H	12-bit T _{OS} value bit 3~bit 0 (1 LSB=1/16°C)

Temperature Measurement Reference Items – HT67L2540A

Name	Mapped Address in Program Memory	Description
Slope	1FF5H	16-bit Slope value bit 15~bit 8
	1FF6H	16-bit Slope value bit 7~bit 0
T _{OS}	1FE6H	12-bit T _{OS} value bit 11~bit 4
	1FE7H	12-bit T _{OS} value bit 3~bit 0 (1 LSB=1/16°C)

Temperature Measurement Reference Items – HT67L2550A

The Option Memory mapping function is enabled using the ORMC register. For more details, refer to the “Option Memory Mapping Register – ORMC” in the Special Function Register Description section.

A/D Conversion Programming Examples

The following two programming examples illustrate how to setup and implement an A/D conversion. In the first example, the method of polling the ADBZ bit in the SADC0 register is used to detect when the conversion cycle is complete, whereas in the second example, the A/D interrupt is used to determine when the conversion is complete.

Example: using an ADBZ polling method to detect the end of conversion

```

clr ADE                ; disable ADC interrupt
mov a, 02H
mov SADC2, a           ; select 12-bit resolution mode and A/D converter clock rate is
                        ; up to 2MHz disable temperature sensor circuitry

mov a, 0BH
mov SADC1, a           ; select A/D input signal from external channel input, reference
                        ; voltage from A/D internal power and fsys/8 as A/D clock

mov a, 02h
mov PBS0, a           ; set PBS0 register to configure pin AN0
mov a, 20h
mov SADC0, a           ; enable A/D converter and connect AN0 channel to A/D converter
:
start_conversion:
clr START              ; high pulse on start bit to initiate conversion
set START              ; reset A/D
clr START              ; start A/D
polling_EOC:
sz ADBZ                ; poll the SADC0 register ADBZ bit to detect end of A/D
                        ; conversion
jmp polling_EOC        ; continue polling
mov a, SADOL            ; read low byte conversion result value
mov SADOL_buffer, a    ; save result to user defined register
mov a, SADOH            ; read high byte conversion result value
mov SADOH_buffer, a    ; save result to user defined register
:
:
jmp start_conversion   ; start next A/D conversion

```

Example: using the interrupt method to detect the end of conversion

```

clr ADE                ; disable ADC interrupt
mov a, 02H
mov SADC2, a           ; select 12-bit resolution mode and A/D converter clock rate is
                        ; up to 2MHz disable temperature sensor circuitry

mov a, 0BH
mov SADC1, a           ; select A/D input signal from external channel input, reference
                        ; voltage from A/D internal power and fsys/8 as A/D clock

mov a, 02h
mov PBS0, a           ; set PBS0 register to configure pin AN0
mov a, 20h
mov SADC0, a           ; enable A/D converter and connect AN0 channel to A/D converter
Start_conversion:
clr START              ; high pulse on START bit to initiate conversion
set START              ; reset A/D
clr START              ; start A/D
clr ADF                ; clear ADC interrupt request flag
set ADE                ; enable ADC interrupt
set EMI                ; enable global interrupt
:
:

```

```
; ADC interrupt service routine
ADC_ISR:
mov  acc_stack, a      ; save ACC to user defined memory
mov  a, STATUS
mov  status_stack, a   ; save STATUS to user defined memory
:
:
mov  a, SADO_L         ; read low byte conversion result value
mov  SADO_L_buffer, a ; save result to user defined register
mov  a, SADO_H         ; read high byte conversion result value
mov  SADO_H_buffer, a ; save result to user defined register
:
:
EXIT_INT_ISR:
mov  a, status_stack
mov  STATUS, a        ; restore STATUS from user defined memory
mov  a, acc_stack     ; restore ACC from user defined memory
reti
```

Universal Serial Interface Module – USIM

The devices contain a Universal Serial Interface Module, which includes the four-line SPI interface, the two-line I²C interface and the two-line/single-line UART interface types, to allow an easy method of communication with external peripheral hardware. Having relatively simple communication protocols, these serial interface types allow the microcontroller to interface to external SPI, I²C or UART based hardware such as sensors, Flash or EEPROM memory, etc. The USIM interface pins are pin-shared with other I/O pins therefore the USIM interface functional pins must first be selected using the corresponding pin-shared function selection bits. As all the interface types share the same pins and registers, the choice of whether the UART, SPI or I²C type is used is made using the UART mode selection bit, named UMD, and the SPI/I²C operating mode control bits, named SIM2~SIM0, in the SIMC0 register. These pull-high resistors of the USIM pin-shared I/O pins are selected using pull-high control registers when the USIM function is enabled and the corresponding pins are used as USIM input pins.

SPI Interface

The SPI interface is often used to communicate with external peripheral devices such as sensors, Flash or EEPROM memory devices etc. Originally developed by Motorola, the four line SPI interface is a synchronous serial data interface that has a relatively simple communication protocol simplifying the programming requirements when communicating with external hardware devices.

The communication is full duplex and operates as a slave/master type, where the device can be either master or slave. Although the SPI interface specification can control multiple slave devices from a single master, but the device provides only one $\overline{\text{SCS}}$ pin. If the master needs to control multiple slave devices from a single master, the master can use I/O pin to select the slave devices.

SPI Interface Operation

The SPI interface is a full duplex synchronous serial data link. It is a four-line interface with pin names SDI, SDO, SCK and $\overline{\text{SCS}}$. Pins SDI and SDO are the Serial Data Input and Serial Data Output lines, the SCK pin is the Serial Clock line and $\overline{\text{SCS}}$ is the Slave Select line. As the SPI interface pins are pin-shared with normal I/O pins and with the I²C/UART function pins, the SPI interface pins must first be selected by configuring the pin-shared function selection bits and setting the correct bits in the SIMC0 and SIMC2 registers. Communication between devices connected to the SPI interface is carried out in a slave/master mode with all data transfer initiations being

implemented by the master. The Master also controls the clock signal. As the device only contains a single $\overline{\text{SCS}}$ pin only one slave device can be utilized. The $\overline{\text{SCS}}$ pin is controlled by software, set CSEN bit to 1 to enable $\overline{\text{SCS}}$ pin function, set CSEN bit to 0 the $\overline{\text{SCS}}$ pin will be floating state.

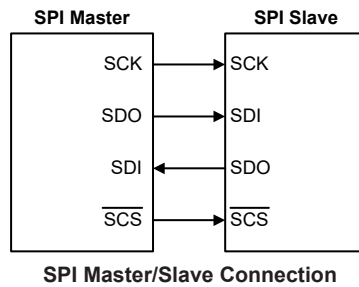

The SPI function in the device offers the following features:

- Full duplex synchronous data transfer
- Both Master and Slave modes
- LSB first or MSB first data transmission modes
- Transmission complete flag
- Rising or falling active clock edge

The status of the SPI interface pins is determined by a number of factors such as whether the device is in the master or slave mode and upon the condition of certain control bits such as CSEN and SIMEN.

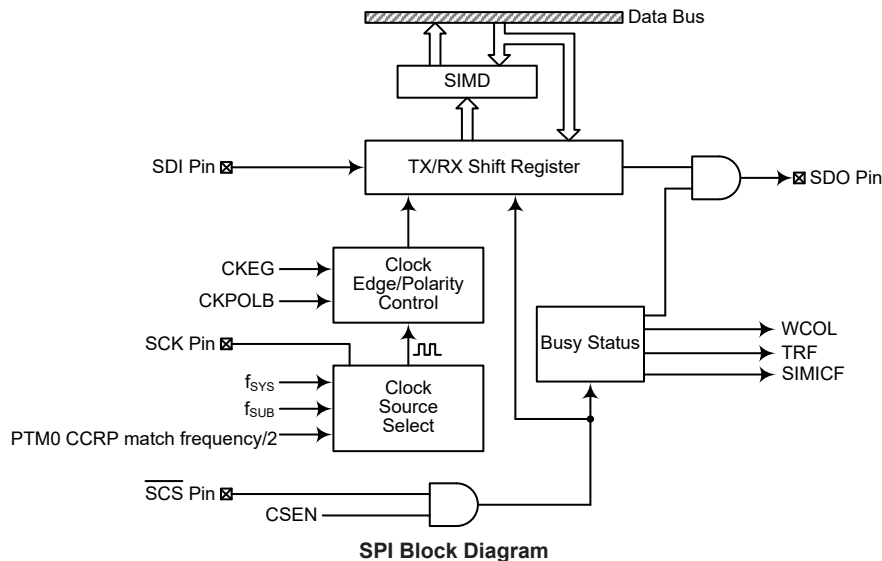

SPI Registers

There are three internal registers which control the overall operation of the SPI interface. These are the SIMD data register and two control registers, SIMC0 and SIMC2. Note that the SIMC2 and SIMD registers and their POR values are only available when the SPI mode is selected by properly configuring the UMD and SIM2~SIM0 bits in the SIMC0 register.

Register Name	Bit							
	7	6	5	4	3	2	1	0
SIMC0	SIM2	SIM1	SIM0	UMD	SIMDEB1	SIMDEB0	SIMEN	SIMICF
SIMC2	D7	D6	CKPOLB	CKEG	MLS	CSEN	WCOL	TRF
SIMD	D7	D6	D5	D4	D3	D2	D1	D0

SPI Register List

SPI Data Register

The SIMD register is used to store the data being transmitted and received. The same register is used by both the SPI and I²C functions. Before the device writes data to the SPI bus, the actual data to be transmitted must be placed in the SIMD register. After the data is received from the SPI bus, the device can read it from the SIMD register. Any transmission or reception of data from the SPI bus must be made via the SIMD register.

• SIMD Register

Bit	7	6	5	4	3	2	1	0
Name	D7	D6	D5	D4	D3	D2	D1	D0
R/W	R/W	R/W	R/W	R/W	R/W	R/W	R/W	R/W
POR	x	x	x	x	x	x	x	x

"x": unknown

Bit 7~0 **D7~D0**: USIM SPI/I²C data register bit 7 ~ bit 0

SPI Control Registers

There are also two control registers for the SPI interface, SIMC0 and SIMC2. The SIMC0 register is used to control the enable/disable function and to set the data transmission clock frequency. The SIMC2 register is used for other control functions such as LSB/MSB selection, write collision flag etc.

• SIMC0 Register

Bit	7	6	5	4	3	2	1	0
Name	SIM2	SIM1	SIM0	UMD	SIMDEB1	SIMDEB0	SIMEN	SIMICF
R/W	R/W	R/W	R/W	R/W	R/W	R/W	R/W	R/W
POR	1	1	1	0	0	0	0	0

Bit 7~5 **SIM2~SIM0**: USIM SPI/I²C Operating Mode Control

- 000: SPI master mode; SPI clock is $f_{SYS}/4$
- 001: SPI master mode; SPI clock is $f_{SYS}/16$
- 010: SPI master mode; SPI clock is $f_{SYS}/64$
- 011: SPI master mode; SPI clock is f_{SUB}
- 100: SPI master mode; SPI clock is PTM0 CCRP match frequency/2
- 101: SPI slave mode
- 110: I²C slave mode
- 111: Unused mode

When the UMD bit is cleared to zero, these bits setup the SPI or I²C operating mode of the USIM function. As well as selecting if the I²C or SPI function, they are used to control the SPI Master/Slave selection and the SPI Master clock frequency. The SPI clock is a function of the system clock but can also be chosen to be sourced from PTM0 and f_{SUB} . If the SPI Slave Mode is selected then the clock will be supplied by an external Master device.

- Bit 4 **UMD**: UART mode selection bit
 0: SPI or I²C mode
 1: UART mode
 This bit is used to select the UART mode. When this bit is cleared to zero, the actual SPI or I²C mode can be selected using the SIM2~SIM0 bits. Note that the UMD bit must be cleared to zero for SPI or I²C mode.
- Bit 3~2 **SIMDEB1~SIMDEB0**: I²C Debounce Time Selection
 These bits are only available when the USIM is configured to operate in the I²C mode. Refer to the I²C register section.
- Bit 1 **SIMEN**: USIM SPI/I²C Enable Control
 0: Disable
 1: Enable
 The bit is the overall on/off control for the USIM SPI/I²C interface. When the SIMEN bit is cleared to zero to disable the USIM SPI/I²C interface, the SDI, SDO, SCK and \overline{SCS} , or SDA and SCL lines will lose their SPI or I²C function and the USIM operating current will be reduced to a minimum value. When the bit is high the USIM SPI/I²C interface is enabled. If the USIM is configured to operate as an SPI interface via the UMD and SIM2~SIM0 bits, the contents of the SPI control registers will remain at the previous settings when the SIMEN bit changes from low to high and should therefore be first initialised by the application program. If the USIM is configured to operate as an I²C interface via the UMD and SIM2~SIM0 bits and the SIMEN bit changes from low to high, the contents of the I²C control bits such as HTX and TXAK will remain at the previous settings and should therefore be first initialised by the application program while the relevant I²C flags such as HCF, HAAS, HBB, SRW and RXAK will be set to their default states.
- Bit 0 **SIMICF**: USIM SPI Incomplete Flag
 0: USIM SPI incomplete condition is not occurred
 1: USIM SPI incomplete condition is occurred
 This bit is only available when the USIM is configured to operate in an SPI slave mode. If the SPI operates in the slave mode with the SIMEN and CSEN bits both being set high but the \overline{SCS} line is pulled high by the external master device before the SPI data transfer is completely finished, the SIMICF bit will be set high together with the TRF bit. When this condition occurs, the corresponding interrupt will occur if the interrupt function is enabled. However, the TRF bit will not be set high if the SIMICF bit is set high by software application program.

• **SIMC2 Register**

Bit	7	6	5	4	3	2	1	0
Name	D7	D6	CKPOLB	CKEG	MLS	CSEN	WCOL	TRF
R/W	R/W	R/W	R/W	R/W	R/W	R/W	R/W	R/W
POR	0	0	0	0	0	0	0	0

- Bit 7~6 **D7~D6**: Undefined bits
 These bits can be read or written by application program.
- Bit 5 **CKPOLB**: SPI clock line base condition selection
 0: The SCK line will be high when the clock is inactive
 1: The SCK line will be low when the clock is inactive
 The CKPOLB bit determines the base condition of the clock line, if the bit is high, then the SCK line will be low when the clock is inactive. When the CKPOLB bit is low, then the SCK line will be high when the clock is inactive.
- Bit 4 **CKEG**: SPI SCK active clock edge type selection
 CKPOLB=0
 0: SCK is high base level and data capture at SCK rising edge
 1: SCK is high base level and data capture at SCK falling edge

CKPOLB=1

0: SCK is low base level and data capture at SCK falling edge

1: SCK is low base level and data capture at SCK rising edge

The CKEG and CKPOLB bits are used to setup the way that the clock signal outputs and inputs data on the SPI bus. These two bits must be configured before data transfer is executed otherwise an erroneous clock edge may be generated. The CKPOLB bit determines the base condition of the clock line, if the bit is high, then the SCK line will be low when the clock is inactive. When the CKPOLB bit is low, then the SCK line will be high when the clock is inactive. The CKEG bit determines active clock edge type which depends upon the condition of CKPOLB bit.

Bit 3 **MLS**: SPI data shift order

0: LSB first

1: MSB first

This is the data shift select bit and is used to select how the data is transferred, either MSB or LSB first. Setting the bit high will select MSB first and low for LSB first.

Bit 2 **CSEN**: SPI \overline{SCS} pin control

0: Disable

1: Enable

The CSEN bit is used as an enable/disable for the \overline{SCS} pin. If this bit is low, then the \overline{SCS} pin will be disabled and placed into a floating condition. If the bit is high the \overline{SCS} pin will be enabled and used as a select pin.

Bit 1 **WCOL**: SPI write collision flag

0: No collision

1: Collision

The WCOL flag is used to detect if a data collision has occurred. If this bit is high it means that data has been attempted to be written to the SIMD register during a data transfer operation. This writing operation will be ignored if data is being transferred. The bit can be cleared to zero by the application program.

Bit 0 **TRF**: SPI Transmit/Receive complete flag

0: SPI data is being transferred

1: SPI data transmission is completed

The TRF bit is the Transmit/Receive Complete flag and is set to “1” automatically when an SPI data transmission is completed, but must be cleared to “0” by the application program. It can be used to generate an interrupt.

SPI Communication

After the SPI interface is enabled by setting the SIMEN bit high, then in the Master Mode, when data is written to the SIMD register, transmission/reception will begin simultaneously. When the data transfer is completed, the TRF flag will be set high automatically, but must be cleared using the application program. In the Slave Mode, when the clock signal from the master has been received, any data in the SIMD register will be transmitted and any data on the SDI pin will be shifted into the SIMD register. The master should output an \overline{SCS} signal to enable the slave devices before a clock signal is provided. The slave data to be transferred should be well prepared at the appropriate moment relative to the SCK signal depending upon the configurations of the CKPOLB bit and CKEG bit. The accompanying timing diagrams show the relationship between the slave data and SCK signal for various configurations of the CKPOLB and CKEG bits.

The SPI will continue to function in certain IDLE Modes if the clock source used by the SPI interface is still active.

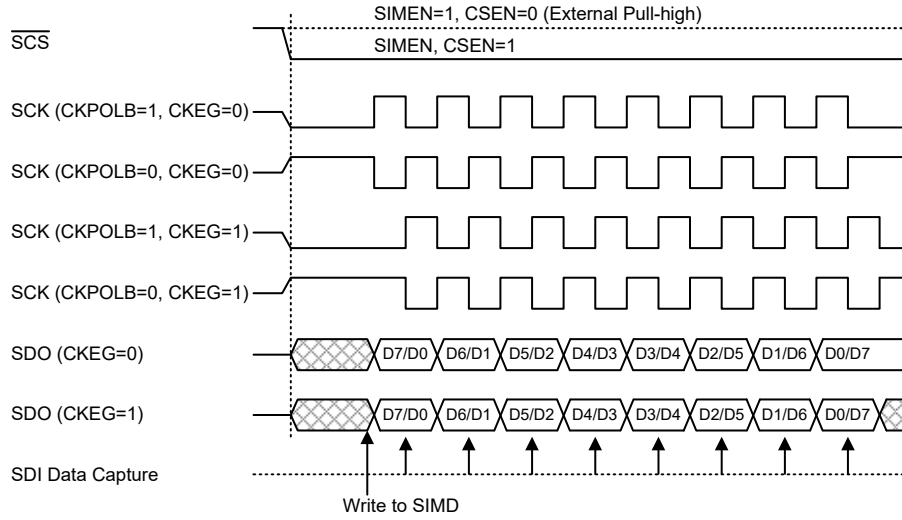

SPI Master Mode Timing

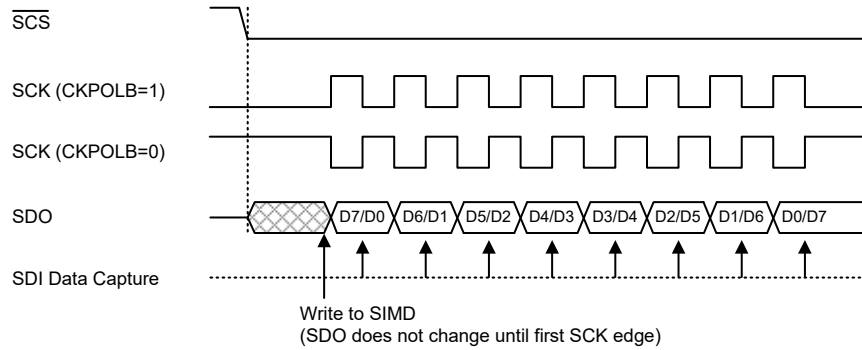

SPI Slave Mode Timing – CKEG=0

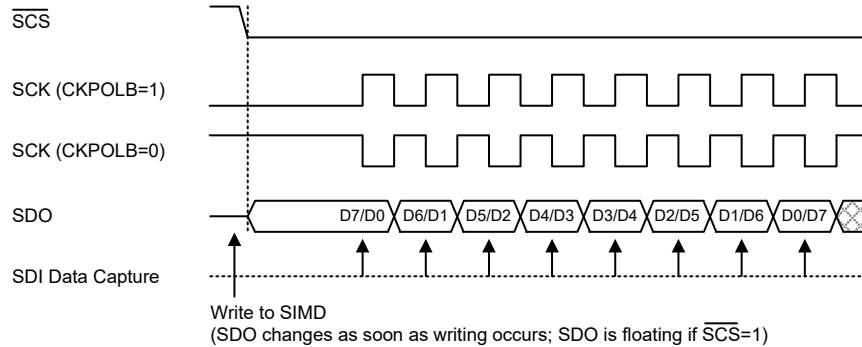

SPI Slave Mode Timing – CKEG=1

Note: For SPI slave mode, if SIMEN=1 and CSEN=0, SPI is always enabled and ignores the \overline{SCS} level.

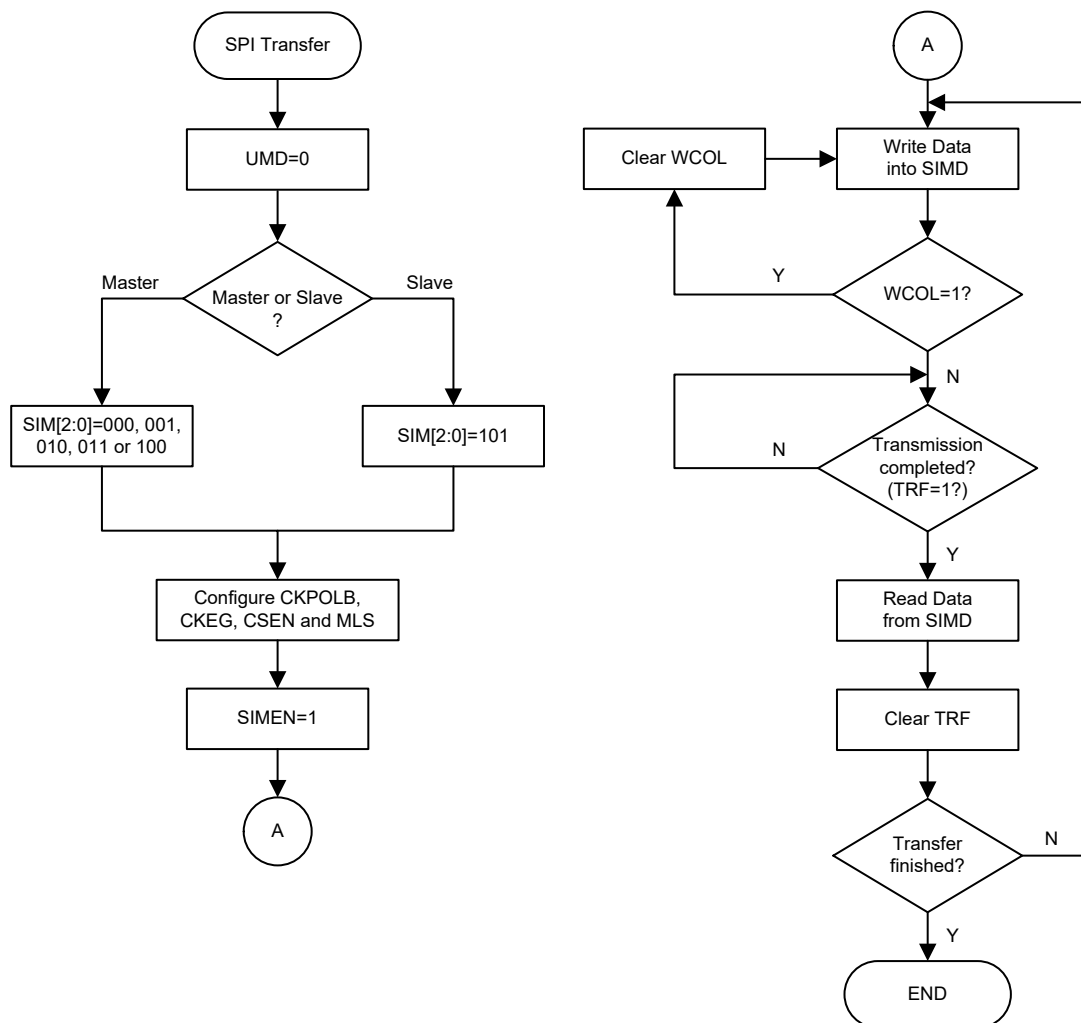

SPI Transfer Control Flowchart

SPI Bus Enable/Disable

To enable the SPI bus, set CSEN=1 and \overline{SCS} =0, then wait for data to be written into the SIMD (TXRX buffer) register. For the Master Mode, after data has been written to the SIMD (TXRX buffer) register, then transmission or reception will start automatically. When all the data has been transferred, the TRF bit should be set. For the Slave Mode, when clock pulses are received on SCK, data in the TXRX buffer will be shifted out or data on SDI will be shifted in.

When the SPI bus is disabled, SCK, SDI, SDO and \overline{SCS} can become I/O pins or other pin-shared functions using the corresponding pin-shared control bits.

SPI Operation Steps

All communication is carried out using the 4-line interface for either Master or Slave Mode.

The CSEN bit in the SIMC2 register controls the \overline{SCS} pin function of the SPI interface. Setting this bit high will enable the SPI interface by allowing the \overline{SCS} line to be active, which can then be used to control the SPI interface. If the CSEN bit is low, the SPI interface will be disabled and the \overline{SCS} line will be in a floating condition and can therefore not be used for control of the SPI interface. If the CSEN bit and the SIMEN bit in the SIMC0 are set high, this will place the SDI

line in a floating condition and the SDO line high. If in Master Mode the SCK line will be either high or low depending upon the clock polarity selection bit CKPOLB in the SIMC2 register. If in Slave Mode the SCK line will be in a floating condition. If the SIMEN bit is low, then the bus will be disabled and \overline{SCS} , SDI, SDO and SCK will all become I/O pins or the other functions using the corresponding pin-shared control bits. In the Master Mode the Master will always generate the clock signal. The clock and data transmission will be initiated after data has been written into the SIMD register. In the Slave Mode, the clock signal will be received from an external master device for both data transmission and reception. The following sequences show the order to be followed for data transfer in both Master and Slave Mode.

Master Mode

- Step 1
Select the SPI Master mode and clock source using the UMD and SIM2~SIM0 bits in the SIMC0 control register.
- Step 2
Setup the CSEN bit and setup the MLS bit to choose if the data is MSB or LSB first, this setting must be the same with the Slave devices.
- Step 3
Setup the SIMEN bit in the SIMC0 control register to enable the SPI interface.
- Step 4
For write operations: write the data to the SIMD register, which will actually place the data into the TXRX buffer. Then use the SCK and SDO lines to output the data. After this, go to step 5.
For read operations: the data transferred in on the SDI line will be stored in the TXRX buffer until all the data has been received at which point it will be latched into the SIMD register.
- Step 5
Check the WCOL bit if set high then a collision error has occurred so return to step 4. If equal to zero then go to the following step.
- Step 6
Check the TRF bit or wait for a USIM SPI serial bus interrupt.
- Step 7
Read data from the SIMD register.
- Step 8
Clear TRF.
- Step 9
Go to step 4.

Slave Mode

- Step 1
Select the SPI Slave mode using the UMD and SIM2~SIM0 bits in the SIMC0 control register.
- Step 2
Setup the CSEN bit and setup the MLS bit to choose if the data is MSB or LSB first, this setting must be the same with the Master devices.
- Step 3
Setup the SIMEN bit in the SIMC0 control register to enable the SPI interface.
- Step 4
For write operations: write the data to the SIMD register, which will actually place the data into the TXRX buffer. Then wait for the master clock SCK and \overline{SCS} signal. After this, go to step 5.

For read operations: the data transferred in on the SDI line will be stored in the TXRX buffer until all the data has been received at which point it will be latched into the SIMD register.

- Step 5
Check the WCOL bit if set high then a collision error has occurred so return to step 4. If equal to zero then go to the following step.
- Step 6
Check the TRF bit or wait for a USIM SPI serial bus interrupt.
- Step 7
Read data from the SIMD register.
- Step 8
Clear TRF.
- Step 9
Go to step 4.

Error Detection

The WCOL bit in the SIMC2 register is provided to indicate errors during data transfer. The bit is set by the SPI serial Interface but must be cleared by the application program. This bit indicates that a data collision has occurred which happens if a write to the SIMD register takes place during a data transfer operation and will prevent the write operation from continuing.

I²C Interface

The I²C interface is used to communicate with external peripheral devices such as sensors, EEPROM memory etc. Originally developed by Philips, it is a two-line low speed serial interface for synchronous serial data transfer. The advantage of only two lines for communication, relatively simple communication protocol and the ability to accommodate multiple devices on the same bus has made it an extremely popular interface type for many applications.

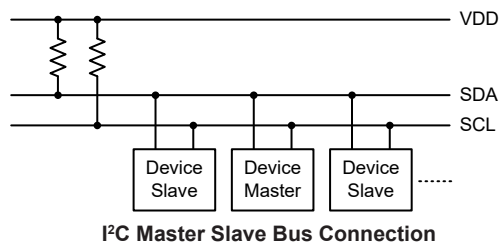

I²C Interface Operation

The I²C serial interface is a two-line interface, a serial data line, SDA, and serial clock line, SCL. As many devices may be connected together on the same bus, their outputs are both open drain types. For this reason it is necessary that external pull-high resistors are connected to these outputs. Note that no chip select line exists, as each device on the I²C bus is identified by a unique address which will be transmitted and received on the I²C bus.

When two devices communicate with each other on the bidirectional I²C bus, one is known as the master device and one as the slave device. Both master and slave can transmit and receive data, however, it is the master device that has overall control of the bus. For the device, which only operates in slave mode, there are two methods of transferring data on the I²C bus, the slave transmit mode and the slave receive mode. The pull-high control function pin-shared with SCL/SDA pin is still applicable even if I²C device is activated and the related internal pull-high register could be controlled by its corresponding pull-high control register.

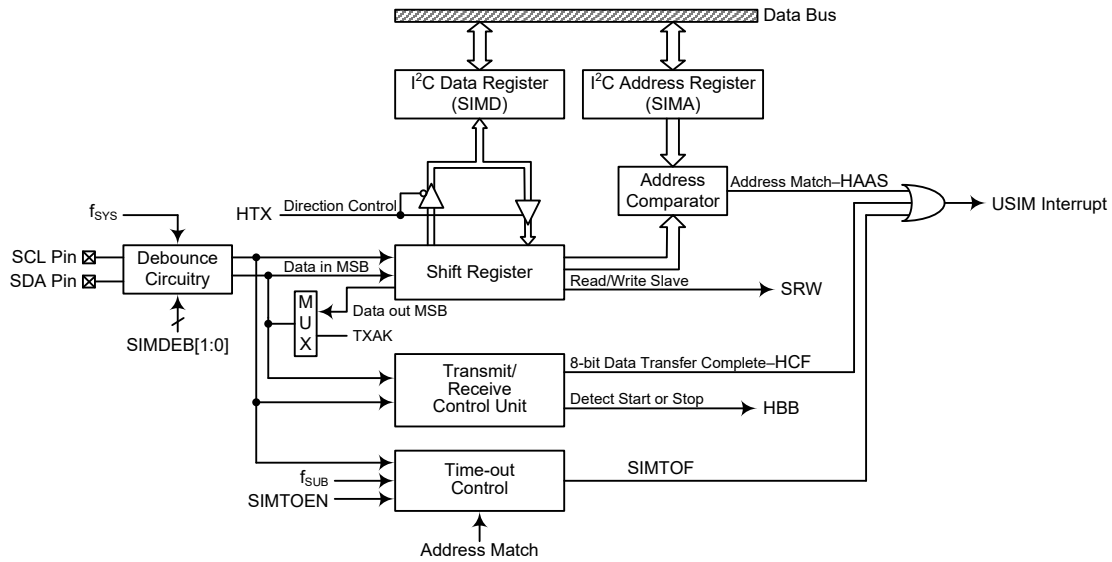

I²C Block Diagram

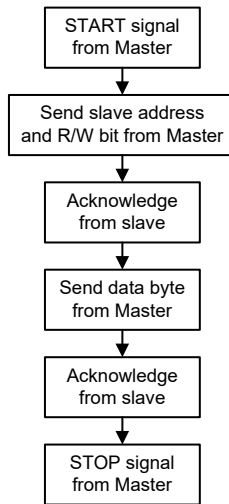

I²C Interface Operation

The SIMDEB1 and SIMDEB0 bits determine the debounce time of the I²C interface. This uses the internal clock to in effect add a debounce time to the external clock to reduce the possibility of glitches on the clock line causing erroneous operation. The debounce time, if selected, can be chosen to be either 2 or 4 system clocks. To achieve the required I²C data transfer speed, there exists a relationship between the system clock, f_{SYS} , and the I²C debounce time. For either the I²C Standard or Fast mode operation, users must take care of the selected system clock frequency and the configured debounce time to match the criterion shown in the following table.

I ² C Debounce Time Selection	I ² C Standard Mode (100kHz)	I ² C Fast Mode (400kHz)
No Debounce	$f_{SYS} > 2\text{MHz}$	$f_{SYS} > 4\text{MHz}$
2 system clock debounce	$f_{SYS} > 4\text{MHz}$	$f_{SYS} > 8\text{MHz}$
4 system clock debounce	$f_{SYS} > 4\text{MHz}$	$f_{SYS} > 8\text{MHz}$

I²C Minimum f_{SYS} Frequency Requirements

I²C Registers

There are three control registers associated with the I²C bus, SIMC0, SIMC1 and SIMTOC, one address register SIMA and one data register, SIMD. Note that the SIMC1, SIMD, SIMA and SIMTOC registers and their POR values are only available when the I²C mode is selected by properly configuring the UMD and SIM2~SIM0 bits in the SIMC0 register.

Register Name	Bit							
	7	6	5	4	3	2	1	0
SIMC0	SIM2	SIM1	SIM0	UMD	SIMDEB1	SIMDEB0	SIMEN	SIMICF
SIMC1	HCF	HAAS	HBB	HTX	TXAK	SRW	IAMWU	RXAK
SIMD	D7	D6	D5	D4	D3	D2	D1	D0
SIMA	SIMA6	SIMA5	SIMA4	SIMA3	SIMA2	SIMA1	SIMA0	D0
SIMTOC	SIMTOEN	SIMTOF	SIMTOS5	SIMTOS4	SIMTOS3	SIMTOS2	SIMTOS1	SIMTOS0

I²C Register List

I²C Data Register

The SIMD register is used to store the data being transmitted and received. The same register is used by both the SPI and I²C functions. Before the device writes data to the I²C bus, the actual data to be transmitted must be placed in the SIMD register. After the data is received from the I²C bus, the device can read it from the SIMD register. Any transmission or reception of data from the I²C bus must be made via the SIMD register.

• SIMD Register

Bit	7	6	5	4	3	2	1	0
Name	D7	D6	D5	D4	D3	D2	D1	D0
R/W	R/W	R/W	R/W	R/W	R/W	R/W	R/W	R/W
POR	x	x	x	x	x	x	x	x

"x": unknown

Bit 7~0 **D7~D0**: USIM SPI/I²C data register bit 7 ~ bit 0

I²C Address Register

The SIMA register is also used by the SPI interface but has the name of SIMC2. The SIMA register is the location where the 7-bit slave address of the slave device is stored. Bits 7~1 of the SIMA register define the device slave address. Bit 0 is not defined. When a master device, which is connected to the I²C bus, sends out an address, which matches the slave address in the SIMA register, the slave device will be selected.

• SIMA Register

Bit	7	6	5	4	3	2	1	0
Name	SIMA6	SIMA5	SIMA4	SIMA3	SIMA2	SIMA1	SIMA0	D0
R/W	R/W	R/W	R/W	R/W	R/W	R/W	R/W	R/W
POR	0	0	0	0	0	0	0	0

Bit 7~1 **SIMA6~SIMA0**: I²C slave address
SIMA6~SIMA0 is the I²C slave address bit 6~bit 0.

Bit 0 **D0**: Reserved bit, can be read or written

I²C Control Registers

There are three control registers for the I²C interface, SIMC0, SIMC1 and SIMTOC. The SIMC0 register is used to control the enable/disable function and to set the data transmission clock frequency. The SIMC1 register contains the relevant flags which are used to indicate the I²C communication status. Another register, SIMTOC, is used to control the I²C time-out function and is described in the corresponding section.

• SIMC0 Register

Bit	7	6	5	4	3	2	1	0
Name	SIM2	SIM1	SIM0	UMD	SIMDEB1	SIMDEB0	SIMEN	SIMICF
R/W	R/W	R/W	R/W	R/W	R/W	R/W	R/W	R/W
POR	1	1	1	0	0	0	0	0

Bit 7~5 **SIM2~SIM0**: USIM SPI/I²C Operating Mode Control
 000: SPI master mode; SPI clock is $f_{SYS}/4$
 001: SPI master mode; SPI clock is $f_{SYS}/16$
 010: SPI master mode; SPI clock is $f_{SYS}/64$
 011: SPI master mode; SPI clock is f_{SUB}
 100: SPI master mode; SPI clock is PTM0 CCRP match frequency/2
 101: SPI slave mode
 110: I²C slave mode
 111: Unused mode

When the UMD bit is cleared to zero, these bits setup the SPI or I²C operating mode of the USIM function. As well as selecting if the I²C or SPI function, they are used to control the SPI Master/Slave selection and the SPI Master clock frequency. The SPI clock is a function of the system clock but can also be chosen to be sourced from PTM0 and f_{SUB} . If the SPI Slave Mode is selected then the clock will be supplied by an external Master device.

Bit 4 **UMD**: UART mode selection bit
 0: SPI or I²C mode
 1: UART mode

This bit is used to select the UART mode. When this bit is cleared to zero, the actual SPI or I²C mode can be selected using the SIM2~SIM0 bits. Note that the UMD bit must be cleared to zero for SPI or I²C mode.

Bit 3~2 **SIMDEB1~SIMDEB0**: I²C Debounce Time Selection
 00: No debounce
 01: 2 system clock debounce
 10: 4 system clock debounce
 11: 4 system clock debounce

These bits are used to select the I²C debounce time when the USIM is configured as the I²C interface function by setting the UMD bit to “0” and SIM2~SIM0 bits to “110”.

Bit 1 **SIMEN**: USIM SPI/I²C Enable Control
 0: Disable
 1: Enable

The bit is the overall on/off control for the USIM SPI/I²C interface. When the SIMEN bit is cleared to zero to disable the USIM SPI/I²C interface, the SDI, SDO, SCK and SCS, or SDA and SCL lines will lose their SPI or I²C function and the USIM operating current will be reduced to a minimum value. When the bit is high the USIM SPI/I²C interface is enabled. If the USIM is configured to operate as an SPI interface via the UMD and SIM2~SIM0 bits, the contents of the SPI control registers will remain at the previous settings when the SIMEN bit changes from low to high and should therefore be first initialised by the application program. If the USIM is configured to operate as an I²C interface via the UMD and SIM2~SIM0 bits and the SIMEN bit changes from low to high, the contents of the I²C control bits such as HTX and TXAK will remain

at the previous settings and should therefore be first initialised by the application program while the relevant I²C flags such as HCF, HAAS, HBB, SRW and RXAK will be set to their default states.

Bit 0 **SIMICF**: USIM SPI Incomplete Flag
 This bit is only available when the USIM is configured to operate in an SPI slave mode. Refer to the SPI register section.

• **SIMC1 Register**

Bit	7	6	5	4	3	2	1	0
Name	HCF	HAAS	HBB	HTX	TXAK	SRW	IAMWU	RXAK
R/W	R	R	R	R/W	R/W	R	R/W	R
POR	1	0	0	0	0	0	0	1

Bit 7 **HCF**: I²C Bus data transfer completion flag
 0: Data is being transferred
 1: Completion of an 8-bit data transfer
 The HCF flag is the data transfer flag. This flag will be zero when data is being transferred. Upon completion of an 8-bit data transfer the flag will go high and an interrupt will be generated. Below is an example of the flow of a two-byte I²C data transfer. First, I²C slave device receives a start signal from I²C master and then HCF bit is automatically cleared to zero. Second, I²C slave device finishes receiving the 1st data byte and then HCF bit is automatically set high. Third, user read the 1st data byte from SIMD register by the application program and then HCF bit is automatically cleared to zero. Fourth, I²C slave device finishes receiving the 2nd data byte and then HCF bit is automatically set to one and so on. Finally, I²C slave device receives a stop signal from I²C master and then HCF bit is automatically set high.

Bit 6 **HAAS**: I²C Bus address match flag
 0: Not address match
 1: Address match
 The HAAS flag is the address match flag. This flag is used to determine if the slave device address is the same as the master transmit address. If the addresses match then this bit will be high, if there is no match then the flag will be low.

Bit 5 **HBB**: I²C Bus busy flag
 0: I²C Bus is not busy
 1: I²C Bus is busy
 The HBB flag is the I²C busy flag. This flag will be “1” when the I²C bus is busy which will occur when a START signal is detected. The flag will be cleared to “0” when the bus is free which will occur when a STOP signal is detected.

Bit 4 **HTX**: I²C slave device is transmitter or receiver selection
 0: Slave device is the receiver
 1: Slave device is the transmitter

Bit 3 **TXAK**: I²C Bus transmit acknowledge flag
 0: Slave send acknowledge flag
 1: Slave do not send acknowledge flag
 The TXAK bit is the transmit acknowledge flag. After the slave device receipt of 8 bits of data, this bit will be transmitted to the bus on the 9th clock from the slave device. The slave device must always set TXAK bit to “0” before further data is received.

Bit 2 **SRW**: I²C Slave Read/Write flag
 0: Slave device should be in receive mode
 1: Slave device should be in transmit mode
 The SRW flag is the I²C Slave Read/Write flag. This flag determines whether the master device wishes to transmit or receive data from the I²C bus. When the transmitted address and slave address is match, that is when the HAAS flag is set high, the slave device will check the SRW flag to determine whether it should be in transmit

mode or receive mode. If the SRW flag is high, the master is requesting to read data from the bus, so the slave device should be in transmit mode. When the SRW flag is zero, the master will write data to the bus, therefore the slave device should be in receive mode to read this data.

Bit 1 **IAMWU**: I²C Address Match Wake-up control
 0: Disable
 1: Enable

This bit should be set high to enable the I²C address match wake-up from the SLEEP or IDLE Mode. If the IAMWU bit has been set before entering either the SLEEP or IDLE mode to enable the I²C address match wake-up, then this bit must be cleared to zero by the application program after wake-up to ensure correction device operation.

Bit 0 **RXAK**: I²C Bus Receive acknowledge flag
 0: Slave receive acknowledge flag
 1: Slave does not receive acknowledge flag

The RXAK flag is the receiver acknowledge flag. When the RXAK flag is “0”, it means that an acknowledge signal has been received at the 9th clock, after 8 bits of data have been transmitted. When the slave device in the transmit mode, the slave device checks the RXAK flag to determine if the master receiver wishes to receive the next byte. The slave transmitter will therefore continue sending out data until the RXAK flag is “1”. When this occurs, the slave transmitter will release the SDA line to allow the master to send a STOP signal to release the I²C Bus.

I²C Bus Communication

Communication on the I²C bus requires four separate steps, a START signal, a slave device address transmission, a data transmission and finally a STOP signal. When a START signal is placed on the I²C bus, all devices on the bus will receive this signal and be notified of the imminent arrival of data on the bus. The first seven bits of the data will be the slave address with the first bit being the MSB. If the address of the slave device matches that of the transmitted address, the HAAS bit in the SIMC1 register will be set and an USIM interrupt will be generated. After entering the interrupt service routine, the slave device must first check the condition of the HAAS and SIMTOF bits to determine whether the interrupt source originates from an address match or from the completion of an 8-bit data transfer completion or from the I²C bus time-out occurrence. During a data transfer, note that after the 7-bit slave address has been transmitted, the following bit, which is the 8th bit, is the read/write bit whose value will be placed in the SRW bit. This bit will be checked by the slave device to determine whether to go into transmit or receive mode. Before any transfer of data to or from the I²C bus, the microcontroller must initialise the bus, the following are steps to achieve this:

- Step 1
Set the UMD, SIM2~SIM0 and SIMEN bits in the SIMC0 register to “0”, “110” and “1” respectively to enable the I²C bus.
- Step 2
Write the slave address of the device to the I²C bus address register SIMA.
- Step 3
Set the USIME interrupt enable bit of the interrupt control register to enable the USIM interrupt.

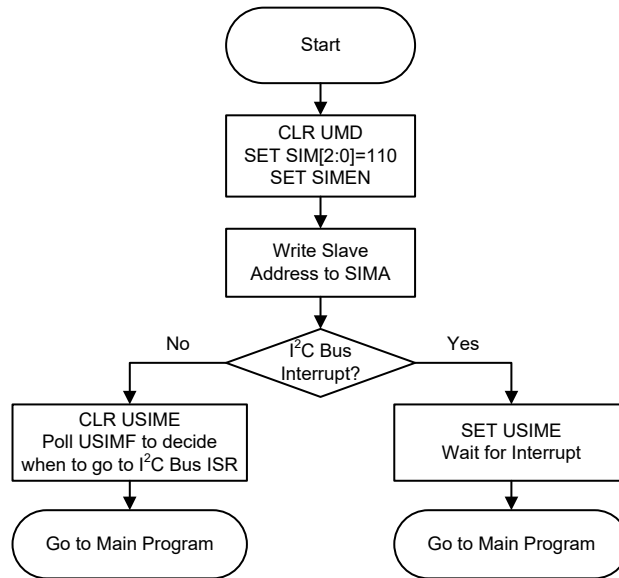

I²C Bus Initialisation Flow Chart

I²C Bus Start Signal

The START signal can only be generated by the master device connected to the I²C bus and not by the slave device. This START signal will be detected by all devices connected to the I²C bus. When detected, this indicates that the I²C bus is busy and therefore the HBB bit will be set. A START condition occurs when a high to low transition on the SDA line takes place when the SCL line remains high.

I²C Slave Address

The transmission of a START signal by the master will be detected by all devices on the I²C bus. To determine which slave device the master wishes to communicate with, the address of the slave device will be sent out immediately following the START signal. All slave devices, after receiving this 7-bit address data, will compare it with their own 7-bit slave address. If the address sent out by the master matches the internal address of the microcontroller slave device, then an internal USIM I²C bus interrupt signal will be generated. The next bit following the address, which is the 8th bit, defines the read/write status and will be saved to the SRW bit of the SIMC1 register. The slave device will then transmit an acknowledge bit, which is a low level, as the 9th bit. The slave device will also set the status flag HAAS when the addresses match.

As an USIM I²C bus interrupt signal can come from three sources, when the program enters the interrupt subroutine, the HAAS and SIMTOF bits should be examined to see whether the interrupt source has come from a matching slave address or from the completion of a data byte transfer or from the I²C bus time-out occurrence. When a slave address is matched, the device must be placed in either the transmit mode and then write data to the SIMD register, or in the receive mode where it must implement a dummy read from the SIMD register to release the SCL line.

I²C Bus Read/Write Signal

The SRW bit in the SIMC1 register defines whether the master device wishes to read data from the I²C bus or write data to the I²C bus. The slave device should examine this bit to determine if it is to be a transmitter or a receiver. If the SRW flag is "1" then this indicates that the master device wishes to read data from the I²C bus, therefore the slave device must be setup to send data to the I²C bus as a transmitter. If the SRW flag is "0" then this indicates that the master wishes to send data to the I²C bus, therefore the slave device must be setup to read data from the I²C bus as a receiver.

I²C Bus Slave Address Acknowledge Signal

After the master has transmitted a calling address, any slave device on the I²C bus, whose own internal address matches the calling address, must generate an acknowledge signal. The acknowledge signal will inform the master that a slave device has accepted its calling address. If no acknowledge signal is received by the master then a STOP signal must be transmitted by the master to end the communication. When the HAAS flag is high, the addresses have matched and the slave device must check the SRW flag to determine if it is to be a transmitter or a receiver. If the SRW flag is high, the slave device should be setup to be a transmitter so the HTX bit in the SIMC1 register should be set to “1”. If the SRW flag is low, then the microcontroller slave device should be setup as a receiver and the HTX bit in the SIMC1 register should be cleared to “0”.

I²C Bus Data and Acknowledge Signal

The transmitted data is 8-bit wide and is transmitted after the slave device has acknowledged receipt of its slave address. The order of serial bit transmission is the MSB first and the LSB last. After receipt of 8 bits of data, the receiver must transmit an acknowledge signal, level “0”, before it can receive the next data byte. If the slave transmitter does not receive an acknowledge bit signal from the master receiver, then the slave transmitter will release the SDA line to allow the master to send a STOP signal to release the I²C Bus. The corresponding data will be stored in the SIMD register. If setup as a transmitter, the slave device must first write the data to be transmitted into the SIMD register. If setup as a receiver, the slave device must read the transmitted data from the SIMD register.

When the slave receiver receives the data byte, it must generate an acknowledge bit, known as TXAK, on the 9th clock. The slave device, which is setup as a transmitter will check the RXAK bit in the SIMC1 register to determine if it is to send another data byte, if not then it will release the SDA line and await the receipt of a STOP signal from the master.

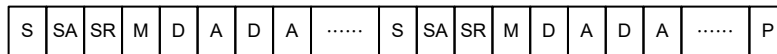
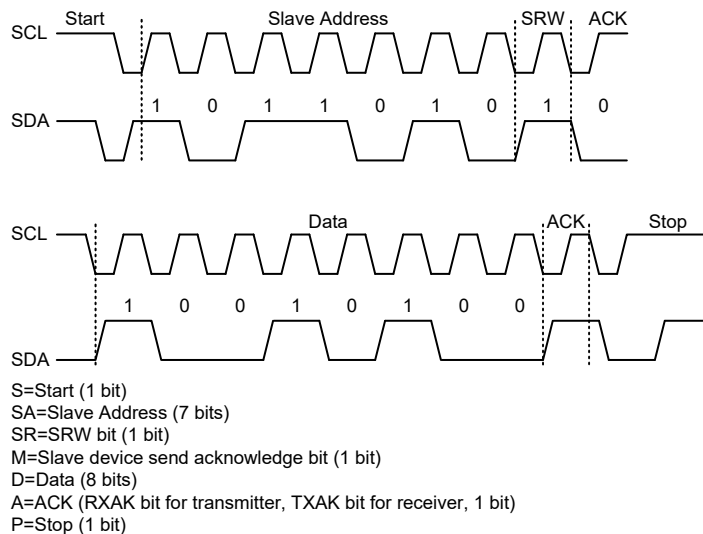

I²C Communication Timing Diagram

Note: When a slave address is matched, the device must be placed in either the transmit mode and then write data to the SIMD register, or in the receive mode where it must implement a dummy read from the SIMD register to release the SCL line.

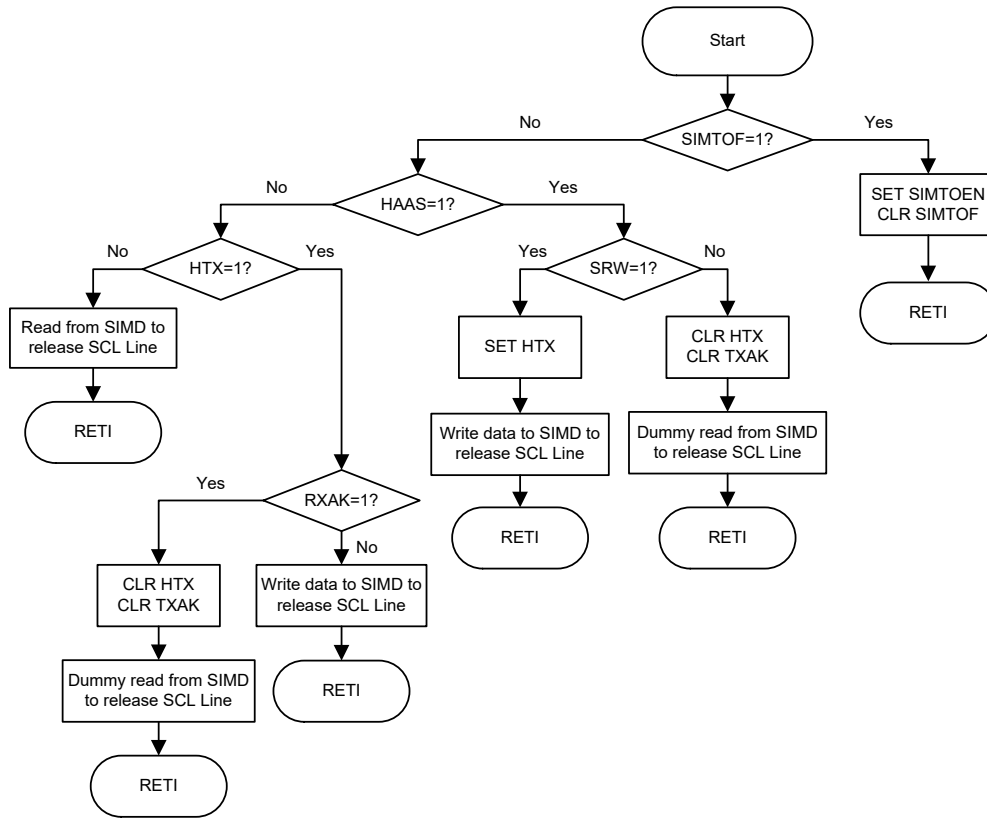

I²C Bus ISR Flow Chart

I²C Time-out Control

In order to reduce the problem of I²C lockup due to reception of erroneous clock sources, a time-out function is provided. If the clock source to the I²C is not received for a while, then the I²C circuitry and registers will be reset after a certain time-out period. The time-out counter starts counting on an I²C bus “START” & “address match” condition, and is cleared by an SCL falling edge. Before the next SCL falling edge arrives, if the time elapsed is greater than the time-out setup by the SIMTOC register, then a time-out condition will occur. The time-out function will stop when an I²C “STOP” condition occurs.

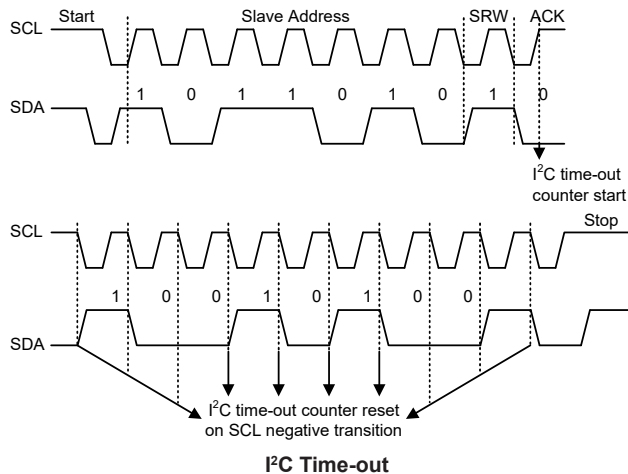

When an I²C time-out counter overflow occurs, the counter will stop and the SIMTOEN bit will be cleared to zero and the SIMTOF bit will be set high to indicate that a time-out condition has occurred. The time-out condition will also generate an interrupt which uses the USIM interrupt vector. When an I²C time-out occurs, the I²C internal circuitry will be reset and the registers will be reset into the following condition:

Registers	After I ² C Time-out
SIMD, SIMA, SIMC0	No change
SIMC1	Reset to POR condition

I²C Registers after Time-out

The SIMTOF flag can be cleared by the application program. There are 64 time-out periods which can be selected using SIMTOS5~SIMTOS0 bits in the SIMTOC register. The time-out time is given by the formula: $((1\sim64)\times 32)/f_{SUB}$. This gives a time-out period which ranges from about 1ms to 64ms.

• **SIMTOC Register**

Bit	7	6	5	4	3	2	1	0
Name	SIMTOEN	SIMTOF	SIMTOS5	SIMTOS4	SIMTOS3	SIMTOS2	SIMTOS1	SIMTOS0
R/W	R/W	R/W	R/W	R/W	R/W	R/W	R/W	R/W
POR	0	0	0	0	0	0	0	0

Bit 7 **SIMTOEN**: USIM I²C Time-out control
0: Disable
1: Enable

Bit 6 **SIMTOF**: USIM I²C Time-out flag
0: No time-out occurred
1: Time-out occurred

This bit is set high when time-out occurs and can only be cleared to zero by application program.

Bit 5~0 **SIMTOS5~SIMTOS0**: USIM I²C Time-out period selection
I²C time-out clock source is $f_{SUB}/32$.
I²C time-out time is equal to $(SIMTOS[5:0]+1)\times(32/f_{SUB})$.

UART Interface

The devices contain an integrated full-duplex or half-duplex asynchronous serial communication UART interface that enables communication with external devices that contain a serial interface. The UART function has many features and can transmit and receive data serially by transferring a frame of data with eight or nine data bits per transmission as well as being able to detect errors when the data is overwritten or incorrectly framed. The UART function shares the same internal interrupt vector with the SPI and I²C interfaces which can be used to indicate when a reception occurs or when a transmission terminates.

The integrated UART function contains the following features:

- Full-duplex or half-duplex (single wire mode) asynchronous communication
- 8 or 9 bits character length
- Even, odd or no parity options
- One or two stop bits
- Baud rate generator with 8-bit prescaler
- Parity, framing, noise and overrun error detection

- Support for interrupt on address detect (last character bit=1)
- Separately enabled transmitter and receiver
- 2-byte Deep FIFO Receive Data Buffer
- URX/UTX pin wake-up function
- Transmit and receive interrupts
- Interrupts can be triggered by the following conditions:
 - ♦ Transmitter Empty
 - ♦ Transmitter Idle
 - ♦ Receiver Full
 - ♦ Receiver Overrun
 - ♦ Address Mode Detect

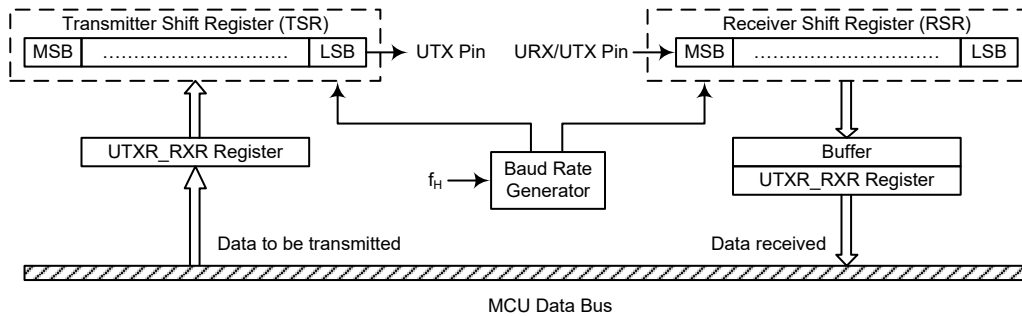

UART Data Transfer Block Diagram – USWM=0

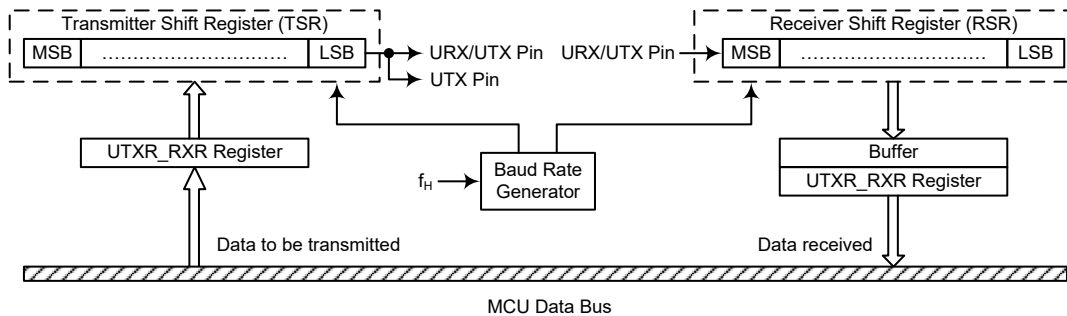

UART Data Transfer Block Diagram – USWM=1

UART External Pins

To communicate with an external serial interface, the internal UART has two external pins known as UTX pin and URX/UTX pin, which are pin-shared with I/O or other pin functions. The UTX and URX/UTX pin function should first be selected by the corresponding pin-shared function selection register before the UART function is used. Along with the UMD bit, the UREN bit, the UTXEN or URXEN bits, if set, will setup these pins to transmitter output and receiver input conditions. At this time the internal pull-high resistor related to the transmitter output pin will be disabled, while the internal pull-high resistor related to the receiver input pin is controlled by the corresponding I/O pull-high function control bit. When the UTX or URX/UTX pin function is disabled by clearing the UMD, UREN, UTXEN or URXEN bit, the UTX or URX/UTX pin will be set to a floating state. At this time whether the internal pull-high resistor is connected to the UTX or URX/UTX pin or not is determined by the corresponding I/O pull-high function control bit.

UART Single Wire Mode

The UART function also supports a Single Wire Mode communication which is selected using the USWM bit in the UUCR3 register. When the USWM bit is set high, the UART function will be in the single wire mode. In the single wire mode, a single URX/UTX pin can be used to transmit and receive data depending upon the corresponding control bits. When the URXEN bit is set high, the URX/UTX pin is used as a receiver pin. When the URXEN bit is cleared to zero and the UTXEN bit is set high, the URX/UTX pin will act as a transmitter pin.

It is recommended not to set both the URXEN and UTXEN bits high in the single wire mode. If both the URXEN and UTXEN bits are set high, the URXEN bit will have the priority and the UART will act as a receiver.

It is important to note that the functional description in this UART chapter, which is described from the full-duplex communication standpoint, also applies to the half-duplex (single wire mode) communication except the pin usage. In the single wire mode, the UTX pin mentioned in this chapter should be replaced by the URX/UTX pin to understand the whole UART single wire mode function.

In the single wire mode, the data can also be transmitted on the UTX pin in a transmission operation with proper software configurations. Therefore, the data will be output on the URX/UTX and UTX pins.

UART Data Transfer Scheme

The UART Data Transfer Block Diagram shows the overall data transfer structure arrangement for the UART. The actual data to be transmitted from the MCU is first transferred to the UTXR_RXR register by the application program. The data will then be transferred to the Transmit Shift Register from where it will be shifted out, LSB first, onto the UTX pin at a rate controlled by the Baud Rate Generator. Only the UTXR_RXR register is mapped onto the MCU Data Memory, the Transmit Shift Register is not mapped and is therefore inaccessible to the application program.

Data to be received by the UART is accepted on the external URX/UTX pin, from where it is shifted in, LSB first, to the Receiver Shift Register at a rate controlled by the Baud Rate Generator. When the shift register is full, the data will then be transferred from the shift register to the internal UTXR_RXR register, where it is buffered and can be manipulated by the application program. Only the UTXR_RXR register is mapped onto the MCU Data Memory, the Receiver Shift Register is not mapped and is therefore inaccessible to the application program.

It should be noted that the actual register for data transmission and reception only exists as a single shared register in the Data Memory. This shared register known as the UTXR_RXR register is used for both data transmission and data reception.

UART Status and Control Registers

There are seven control registers associated with the UART function. The UMD bit in the SIMC0 register can be used to select the UART interface. The USWM bit in the UUCR3 register is used to enable/disable the UART Single Wire Mode. The UUSR, UUCR1 and UUCR2 registers control the overall function of the UART, while the UBRG register controls the Baud rate. The actual data to be transmitted and received on the serial interface is managed through the UTXR_RXR data register. Note that UART related registers and their POR values are only available when the UART mode is selected by setting the UMD bit in the SIMC0 register to "1".

Register Name	Bit							
	7	6	5	4	3	2	1	0
SIMC0	SIM2	SIM1	SIM0	UMD	SIMDEB1	SIMDEB0	SIMEN	SIMICF
UUSR	UPERR	UNF	UFERR	UOERR	URIDLE	URXIF	UTIDLE	UTXIF
UUCR1	UREN	UBNO	UPREN	UPRT	USTOPS	UTXBRK	URX8	UTX8
UUCR2	UTXEN	URXEN	UBRGH	UADDEN	UWAKE	URIE	UTIE	UTEIE
UUCR3	—	—	—	—	—	—	—	USWM
UTXR_RXR	UTXR7	UTXR6	UTXR5	UTXR4	UTXR3	UTXR2	UTXR1	UTXR0
UBRG	UBRG7	UBRG6	UBRG5	UBRG4	UBRG3	UBRG2	UBRG1	UBRG0

UART Register List

• **SIMC0 Register**

Bit	7	6	5	4	3	2	1	0
Name	SIM2	SIM1	SIM0	UMD	SIMDEB1	SIMDEB0	SIMEN	SIMICF
R/W	R/W	R/W	R/W	R/W	R/W	R/W	R/W	R/W
POR	1	1	1	0	0	0	0	0

- Bit 7~5 **SIM2~SIM0**: USIM SPI/I²C Operating Mode Control
When the UMD bit is cleared to zero, these bits setup the SPI or I²C operating mode of the USIM function. Refer to the SPI or I²C register section for more details.
- Bit 4 **UMD**: UART mode selection bit
0: SPI or I²C mode
1: UART mode
This bit is used to select the UART mode. When this bit is cleared to zero, the actual SPI or I²C mode can be selected using the SIM2~SIM0 bits. Note that the UMD bit must be cleared to zero for SPI or I²C mode.
- Bit 3~2 **SIMDEB1~SIMDEB0**: I²C Debounce Time Selection
Refer to the I²C register section.
- Bit 1 **SIMEN**: USIM SPI/I²C Enable Control
This bit is only available when the USIM is configured to operate in an SPI or I²C mode with the UMD bit cleared to zero. Refer to the SPI or I²C register section for more details.
- Bit 0 **SIMICF**: USIM SPI Incomplete Flag
Refer to the SPI register section.

• **UUSR Register**

The UUSR register is the status register for the UART, which can be read by the program to determine the present status of the UART. All flags within the UUSR register are read only. Further explanation on each of the flags is given below:

Bit	7	6	5	4	3	2	1	0
Name	UPERR	UNF	UFERR	UOERR	URIDLE	URXIF	UTIDLE	UTXIF
R/W	R	R	R	R	R	R	R	R
POR	0	0	0	0	1	0	1	1

- Bit 7 **UPERR**: Parity error flag
0: No parity error is detected
1: Parity error is detected
The UPERR flag is the parity error flag. When this read only flag is “0”, it indicates a parity error has not been detected. When the flag is “1”, it indicates that the parity of the received word is incorrect. This error flag is applicable only if Parity mode (odd or even) is selected. The flag can also be cleared to zero by a software sequence which

- involves a read to the status register UUSR followed by an access to the UTXR_RXR data register.
- Bit 6 UNF: Noise flag**
 0: No noise is detected
 1: Noise is detected
- The UNF flag is the noise flag. When this read only flag is “0”, it indicates no noise condition. When the flag is “1”, it indicates that the UART has detected noise on the receiver input. The UNF flag is set during the same cycle as the URXIF flag but will not be set in the case of an overrun. The UNF flag can be cleared to zero by a software sequence which will involve a read to the status register UUSR followed by an access to the UTXR_RXR data register.
- Bit 5 UFERR: Framing error flag**
 0: No framing error is detected
 1: Framing error is detected
- The UFERR flag is the framing error flag. When this read only flag is “0”, it indicates that there is no framing error. When the flag is “1”, it indicates that a framing error has been detected for the current character. The flag can also be cleared to zero by a software sequence which will involve a read to the status register UUSR followed by an access to the UTXR_RXR data register.
- Bit 4 UOERR: Overrun error flag**
 0: No overrun error is detected
 1: Overrun error is detected
- The UOERR flag is the overrun error flag which indicates when the receiver buffer has overflowed. When this read only flag is “0”, it indicates that there is no overrun error. When the flag is “1”, it indicates that an overrun error occurs which will inhibit further transfers to the UTXR_RXR receive data register. The flag is cleared to zero by a software sequence, which is a read to the status register UUSR followed by an access to the UTXR_RXR data register.
- Bit 3 URIDLE: Receiver status**
 0: Data reception is in progress (Data being received)
 1: No data reception is in progress (Receiver is idle)
- The URIDLE flag is the receiver status flag. When this read only flag is “0”, it indicates that the receiver is between the initial detection of the start bit and the completion of the stop bit. When the flag is “1”, it indicates that the receiver is idle. Between the completion of the stop bit and the detection of the next start bit, the URIDLE bit is “1” indicating that the UART receiver is idle and the URX/UTX pin stays in logic high condition.
- Bit 2 URXIF: Receive UTXR_RXR data register status**
 0: UTXR_RXR data register is empty
 1: UTXR_RXR data register has available data
- The URXIF flag is the receive data register status flag. When this read only flag is “0”, it indicates that the UTXR_RXR read data register is empty. When the flag is “1”, it indicates that the UTXR_RXR read data register contains new data. When the contents of the shift register are transferred to the UTXR_RXR register, an interrupt is generated if URIE=1 in the UUCR2 register. If one or more errors are detected in the received word, the appropriate receive-related flags UNF, UFERR, and/or UPERR are set within the same clock cycle. The URXIF flag will eventually be cleared to zero when the UUSR register is read with URXIF set, followed by a read from the UTXR_RXR register, and if the UTXR_RXR register has no more new data available.
- Bit 1 UTIDLE: Transmission idle**
 0: Data transmission is in progress (Data being transmitted)
 1: No data transmission is in progress (Transmitter is idle)
- The UTIDLE flag is known as the transmission complete flag. When this read only flag is “0”, it indicates that a transmission is in progress. This flag will be set high when the UTXIF flag is “1” and when there is no transmit data or break character being

transmitted. When UTIDLE is equal to “1”, the UTX pin becomes idle with the pin state in logic high condition. The UTIDLE flag is cleared to zero by reading the UUSR register with UTIDLE set and then writing to the UTXR_RXR register. The flag is not generated when a data character or a break is queued and ready to be sent.

Bit 0

UTXIF: Transmit UTXR_RXR data register status

0: Character is not transferred to the transmit shift register

1: Character has transferred to the transmit shift register (UTXR_RXR data register is empty)

The UTXIF flag is the transmit data register empty flag. When this read only flag is “0”, it indicates that the character is not transferred to the transmitter shift register. When the flag is “1”, it indicates that the transmitter shift register has received a character from the UTXR_RXR data register. The UTXIF flag is cleared to zero by reading the UART status register (UUSR) with UTXIF set and then writing to the UTXR_RXR data register. Note that when the UTXEN bit is set, the UTXIF flag bit will also be set since the transmit data register is not yet full.

• **UUCR1 Register**

The UUCR1 register together with the UUCR2 and UUCR3 registers are the three UART control registers that are used to set the various options for the UART function, such as overall on/off control, parity control, data transfer bit length, single wire mode communication etc. Further explanation on each of the bits is given below:

Bit	7	6	5	4	3	2	1	0
Name	UREN	UBNO	UPREN	UPRT	USTOPS	UTXBRK	URX8	UTX8
R/W	R/W	R/W	R/W	R/W	R/W	R/W	R	W
POR	0	0	0	0	0	0	x	0

“x”: unknown

Bit 7

UREN: UART function enable control

0: Disable UART. UTX and URX/UTX pins are in a floating state

1: Enable UART. UTX and URX/UTX pins function as UART pins

The UREN bit is the UART enable bit. When this bit is equal to “0”, the UART will be disabled and the URX/UTX pin as well as the UTX pin will be set in a floating state. When the bit is equal to “1”, the UART will be enabled if the UMD bit is set and the UTX and URX/UTX pins will function as defined by the USWM mode selection bit together with the UTXEN and URXEN enable control bits.

When the UART is disabled, it will empty the buffer so any character remaining in the buffer will be discarded. In addition, the value of the baud rate counter will be reset. If the UART is disabled, all error and status flags will be reset. Also the UTXEN, URXEN, UTXBRK, URXIF, UOERR, UFERR, UPERR and UNF bits will be cleared to zero, while the UTIDLE, UTXIF and URIDLE bits will be set high. Other control bits in UUCR1, UUCR2, UUCR3 and UBRG registers will remain unaffected. If the UART is active and the UREN bit is cleared to zero, all pending transmissions and receptions will be terminated and the module will be reset as defined above. When the UART is re-enabled, it will restart in the same configuration.

Bit 6

UBNO: Number of data transfer bits selection

0: 8-bit data transfer

1: 9-bit data transfer

This bit is used to select the data length format, which can have a choice of either 8-bit or 9-bit format. When this bit is equal to “1”, a 9-bit data length format will be selected. If the bit is equal to “0”, then an 8-bit data length format will be selected. If 9-bit data length format is selected, then bits URX8 and UTX8 will be used to store the 9th bit of the received and transmitted data respectively.

Note that the 9th bit of data if UBNO=1, or the 8th bit of data if UBNO=0, which is used as the parity bit, does not transfer to URX8 or UTXRX7 respectively when the parity function is enabled.

- Bit 5 **UPREN**: Parity function enable control
 0: Parity function is disabled
 1: Parity function is enabled
 This is the parity enable bit. When this bit is equal to “1”, the parity function will be enabled. If the bit is equal to “0”, then the parity function will be disabled.
- Bit 4 **UPRT**: Parity type selection bit
 0: Even parity for parity generator
 1: Odd parity for parity generator
 This bit is the parity type selection bit. When this bit is equal to “1”, odd parity type will be selected. If the bit is equal to “0”, then even parity type will be selected.
- Bit 3 **USTOPS**: Number of Stop bits selection for transmitter
 0: One stop bit format is used
 1: Two stop bits format is used
 This bit determines if one or two stop bits are to be used for transmitter. When this bit is equal to “1”, two stop bits are used. If this bit is equal to “0”, then only one stop bit is used.
- Bit 2 **UTXBRK**: Transmit break character
 0: No break character is transmitted
 1: Break characters transmit
 The UTXBRK bit is the Transmit Break Character bit. When this bit is “0”, there are no break characters and the UTX pin operates normally. When the bit is “1”, there are transmit break characters and the transmitter will send logic zeros. When this bit is equal to “1”, after the buffered data has been transmitted, the transmitter output is held low for a minimum of a 13-bit length and until the UTXBRK bit is reset.
- Bit 1 **URX8**: Receive data bit 8 for 9-bit data transfer format (read only)
 This bit is only used if 9-bit data transfers are used, in which case this bit location will store the 9th bit of the received data known as URX8. The UBNO bit is used to determine whether data transfers are in 8-bit or 9-bit format.
- Bit 0 **UTX8**: Transmit data bit 8 for 9-bit data transfer format (write only)
 This bit is only used if 9-bit data transfers are used, in which case this bit location will store the 9th bit of the transmitted data known as UTX8. The UBNO bit is used to determine whether data transfers are in 8-bit or 9-bit format.

• **UUCR2 Register**

The UUCR2 register is the second of the UART control registers and serves several purposes. One of its main functions is to control the basic enable/disable operation of the UART Transmitter and Receiver as well as enabling the various USIM UART mode interrupt sources. The register also serves to control the baud rate speed, receiver wake-up enable and the address detect enable. Further explanation on each of the bits is given below:

Bit	7	6	5	4	3	2	1	0
Name	UTXEN	URXEN	UBRGH	UADDEN	UWAKE	URIE	UTIIE	UTEIE
R/W	R/W	R/W	R/W	R/W	R/W	R/W	R/W	R/W
POR	0	0	0	0	0	0	0	0

- Bit 7 **UTXEN**: UART Transmitter enabled control
 0: UART transmitter is disabled
 1: UART transmitter is enabled
 The bit named UTXEN is the Transmitter Enable Bit. When this bit is equal to “0”, the transmitter will be disabled with any pending data transmissions being aborted. In addition the buffers will be reset. In this situation the UTX pin will be set in a floating state.
 If the UTXEN bit is equal to “1” and the UMD and UREN bit are also equal to “1”, the transmitter will be enabled and the UTX pin will be controlled by the UART. Clearing the UTXEN bit during a transmission will cause the data transmission to be

aborted and will reset the transmitter. If this situation occurs, the UTX pin will be set in a floating state.

- Bit 6 **URXEN:** UART Receiver enabled control
 0: UART receiver is disabled
 1: UART receiver is enabled

The bit named URXEN is the Receiver Enable Bit. When this bit is equal to “0”, the receiver will be disabled with any pending data receptions being aborted. In addition the receive buffers will be reset. In this situation the URX/UTX pin will be set in a floating state. If the URXEN bit is equal to “1” and the UMD and UREN bit are also equal to “1”, the receiver will be enabled and the URX/UTX pin will be controlled by the UART. Clearing the URXEN bit during a reception will cause the data reception to be aborted and will reset the receiver. If this situation occurs, the URX/UTX pin will be set in a floating state.

- Bit 5 **UBRGH:** Baud Rate speed selection
 0: Low speed baud rate
 1: High speed baud rate

The bit named UBRGH selects the high or low speed mode of the Baud Rate Generator. This bit, together with the value placed in the baud rate register UBRG, controls the Baud Rate of the UART. If this bit is equal to “1”, the high speed mode is selected. If the bit is equal to “0”, the low speed mode is selected.

- Bit 4 **UADDEN:** Address detect function enable control
 0: Address detect function is disabled
 1: Address detect function is enabled

The bit named UADDEN is the address detect function enable control bit. When this bit is equal to “1”, the address detect function is enabled. When it occurs, if the 8th bit, which corresponds to UTXRX7 if UBNO=0 or the 9th bit, which corresponds to URX8 if UBNO=1, has a value of “1”, then the received word will be identified as an address, rather than data. If the corresponding interrupt is enabled, an interrupt request will be generated each time the received word has the address bit set, which is the 8th or 9th bit depending on the value of UBNO. If the address bit known as the 8th or 9th bit of the received word is “0” with the address detect function being enabled, an interrupt will not be generated and the received data will be discarded.

- Bit 3 **UWAKE:** URX/UTX pin wake-up UART function enable control
 0: URX/UTX pin wake-up UART function is disabled
 1: URX/UTX pin wake-up UART function is enabled

This bit is used to control the wake-up UART function when a falling edge on the URX/UTX pin occurs. Note that this bit is only available when the UART clock (f_{H}) is switched off. There will be no URX/UTX pin wake-up UART function if the UART clock (f_{H}) exists. If the UWAKE bit is set high as the UART clock (f_{H}) is switched off, a UART wake-up request will be initiated when a falling edge on the URX/UTX pin occurs. When this request happens and the corresponding interrupt is enabled, an URX/UTX pin wake-up UART interrupt will be generated to inform the MCU to wake up the UART function by switching on the UART clock (f_{H}) via the application program. Otherwise, the UART function cannot resume even if there is a falling edge on the URX/UTX pin when the UWAKE bit is cleared to zero.

- Bit 2 **URIE:** Receiver interrupt enable control
 0: Receiver related interrupt is disabled
 1: Receiver related interrupt is enabled

This bit enables or disables the receiver interrupt. If this bit is equal to “1” and when the receiver overrun flag UOERR or receive data available flag URXIF is set, the USIM interrupt request flag USIMF will be set. If this bit is equal to “0”, the USIM interrupt request flag USIMF will not be influenced by the condition of the UOERR or URXIF flags.

- Bit 1 **UTIE:** Transmitter Idle interrupt enable control
 0: Transmitter idle interrupt is disabled
 1: Transmitter idle interrupt is enabled

This bit enables or disables the transmitter idle interrupt. If this bit is equal to “1” and when the transmitter idle flag UTIDLE is set, due to a transmitter idle condition, the USIM interrupt request flag USIMF will be set. If this bit is equal to “0”, the USIM interrupt request flag USIMF will not be influenced by the condition of the UTIDLE flag.

Bit 0 **UTEIE**: Transmitter Empty interrupt enable control
 0: Transmitter empty interrupt is disabled
 1: Transmitter empty interrupt is enabled

This bit enables or disables the transmitter empty interrupt. If this bit is equal to “1” and when the transmitter empty flag UTXIF is set, due to a transmitter empty condition, the USIM interrupt request flag USIMF will be set. If this bit is equal to “0”, the USIM interrupt request flag USIMF will not be influenced by the condition of the UTXIF flag.

• **UUCR3 Register**

The UUCR3 register is used to enable the UART Single Wire Mode communication. As the name suggests in the single wire mode the UART communication can be implemented in one single line, URX/UTX, together with the control of the URXEN and UTXEN bits in the UUCR2 register.

Bit	7	6	5	4	3	2	1	0
Name	—	—	—	—	—	—	—	USWM
R/W	—	—	—	—	—	—	—	R/W
POR	—	—	—	—	—	—	—	0

Bit 7~1 Unimplemented, read as “0”

Bit 0 **USWM**: Single Wire Mode enable control
 0: Disable, the URX/UTX pin is used as UART receiver function only
 1: Enable, the URX/UTX pin can be used as UART receiver or transmitter function controlled by the URXEN and UTXEN bits

Note that when the Single Wire Mode is enabled, if both the URXEN and UTXEN bits are high, the URX/UTX pin will just be used as UART receiver input.

• **UTXR_RXR Register**

The UTXR_RXR register is the data register which is used to store the data to be transmitted on the UTX pin or being received from the URX/UTX pin.

Bit	7	6	5	4	3	2	1	0
Name	UTXRX7	UTXRX6	UTXRX5	UTXRX4	UTXRX3	UTXRX2	UTXRX1	UTXRX0
R/W	R/W	R/W	R/W	R/W	R/W	R/W	R/W	R/W
POR	x	x	x	x	x	x	x	x

“x”: unknown

Bit 7~0 **UTXRX7~UTXRX0**: UART Transmit/Receive Data bit 7 ~ bit 0

• **UBRG Register**

Bit	7	6	5	4	3	2	1	0
Name	UBRG7	UBRG6	UBRG5	UBRG4	UBRG3	UBRG2	UBRG1	UBRG0
R/W	R/W	R/W	R/W	R/W	R/W	R/W	R/W	R/W
POR	x	x	x	x	x	x	x	x

“x”: unknown

Bit 7~0 **UBRG7~UBRG0**: Baud Rate values

By programming the UBRGH bit in UUCR2 register which allows selection of the related formula described above and programming the required value in the UBRG register, the required baud rate can be setup.

Note: Baud rate= $f_{H1} / [64 \times (N+1)]$ if UBRGH=0.
 Baud rate= $f_{H1} / [16 \times (N+1)]$ if UBRGH=1.

Baud Rate Generator

To setup the speed of the serial data communication, the UART function contains its own dedicated baud rate generator. The baud rate is controlled by its own internal free running 8-bit timer, the period of which is determined by two factors. The first of these is the value placed in the baud rate register UBRG and the second is the value of the UBRGH bit in the control register UUCR2. The UBRGH bit decides if the baud rate generator is to be used in a high speed mode or low speed mode, which in turn determines the formula that is used to calculate the baud rate. The value N in the UBRG register which is used in the following baud rate calculation formula determines the division factor. Note that N is the decimal value placed in the UBRG register and has a range of between 0 and 255.

UUCR2 UBRGH Bit	0	1
Baud Rate (BR)	$f_H / [64 (N+1)]$	$f_H / [16 (N+1)]$

By programming the UBRGH bit which allows selection of the related formula and programming the required value in the UBRG register, the required baud rate can be setup. Note that because the actual baud rate is determined using a discrete value, N, placed in the UBRG register, there will be an error associated between the actual and requested value. The following example shows how the UBRG register value N and the error value can be calculated.

Calculating the Baud Rate and Error Values

For a clock frequency of 4MHz, and with UBRGH cleared to zero determine the UBRG register value N, the actual baud rate and the error value for a desired baud rate of 4800.

From the above table the desired baud rate $BR = f_H / [64 (N+1)]$

Re-arranging this equation gives $N = [f_H / (BR \times 64)] - 1$

Giving a value for $N = [4000000 / (4800 \times 64)] - 1 = 12.0208$

To obtain the closest value, a decimal value of 12 should be placed into the UBRG register. This gives an actual or calculated baud rate value of $BR = 4000000 / [64 \times (12+1)] = 4808$

Therefore the error is equal to $(4808 - 4800) / 4800 = 0.16\%$

UART Setup and Control

For data transfer, the UART function utilizes a non-return-to-zero, more commonly known as NRZ, format. This is composed of one start bit, eight or nine data bits, and one or two stop bits. Parity is supported by the UART hardware, and can be setup to be even, odd or no parity. For the most common data format, 8 data bits along with no parity and one stop bit, denoted as 8, N, 1, is used as the default setting, which is the setting at power-on. The number of data bits and stop bits, along with the parity, are setup by programming the corresponding UBNO, UPRT, UPREN, and USTOPS bits in the UUCR1 register. The baud rate used to transmit and receive data is setup using the internal 8-bit baud rate generator, while the data is transmitted and received LSB first. Although the UART transmitter and receiver are functionally independent, they both use the same data format and baud rate. In all cases stop bits will be used for data transmission.

Enabling/Disabling the UART Interface

The basic on/off function of the internal UART function is controlled using the UREN bit in the UUCR1 register. When the UART mode is selected by setting the UMD bit in the SIMC0 register to "1", if the UREN, UTXEN and URXEN bits are set, then these two UART pins will act as normal UTX output pin and URX/UTX input pin respectively. If no data is being transmitted on the UTX pin, then it will default to a logic high value.

Clearing the UREN bit will disable the UTX and URX/UTX pin and allow these pins to be used as normal I/O or other pin-shared functional pins by configuring the corresponding pin-shared control bits. When the UART function is disabled the buffer will be reset to an empty condition, at the same time discarding any remaining residual data. Disabling the UART will also reset the error and status flags with bits UTXEN, URXEN, UTXBRK, URXIF, UOERR, UFERR, UPERR and UNF being cleared while bits UTIDLE, UTXIF and URIDLE will be set. The remaining control bits in the UUCR1, UUCR2, UUCR3 and UBRG registers will remain unaffected. If the UREN bit in the UUCR1 register is cleared while the UART is active, then all pending transmissions and receptions will be immediately suspended and the UART will be reset to a condition as defined above. If the UART is then subsequently re-enabled, it will restart again in the same configuration.

Data, Parity and Stop Bit Selection

The format of the data to be transferred is composed of various factors such as data bit length, parity on/off, parity type, address bits and the number of stop bits. These factors are determined by the setup of various bits within the UUCR1 register. The UBNO bit controls the number of data bits which can be set to either 8 or 9, the UPRT bit controls the choice of odd or even parity, the UPREN bit controls the parity on/off function and the USTOPS bit decides whether one or two stop bits are to be used. The following table shows various formats for data transmission. The address bit, which is the MSB of the data byte, identifies the frame as an address character or data if the address detect function is enabled. The number of stop bits, which can be either one or two, is independent of the data length and is only used for the transmitter. There is only one stop bit for the receiver.

Start Bit	Data Bits	Address Bit	Parity Bit	Stop Bit
Example of 8-bit Data Formats				
1	8	0	0	1
1	7	0	1	1
1	7	1	0	1
Example of 9-bit Data Formats				
1	9	0	0	1
1	8	0	1	1
1	8	1	0	1

Transmitter Receiver Data Format

The following diagram shows the transmit and receive waveforms for both 8-bit and 9-bit data formats.

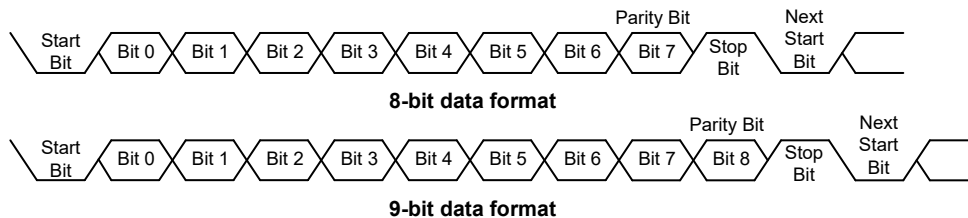

UART Transmitter

Data word lengths of either 8 or 9 bits can be selected by programming the UBNO bit in the UUCR1 register. When UBNO bit is set, the word length will be set to 9 bits. In this case the 9th bit, which is the MSB, needs to be stored in the UTX8 bit in the UUCR1 register. At the transmitter core lies the Transmitter Shift Register, more commonly known as the TSR, whose data is obtained from the transmit data register, which is known as the UTXR_RXR register. The data to be transmitted is loaded into this UTXR_RXR register by the application program. The TSR register is not written to with new data until the stop bit from the previous transmission has been sent out. As soon as this

stop bit has been transmitted, the TSR can then be loaded with new data from the UTXR_RXR register, if it is available. It should be noted that the TSR register, unlike many other registers, is not directly mapped into the Data Memory area and as such is not available to the application program for direct read/write operations. An actual transmission of data will normally be enabled when the UTXEN bit is set, but the data will not be transmitted until the UTXR_RXR register has been loaded with data and the baud rate generator has defined a shift clock source. However, the transmission can also be initiated by first loading data into the UTXR_RXR register, after which the UTXEN bit can be set. When a transmission of data begins, the TSR is normally empty, in which case a transfer to the UTXR_RXR register will result in an immediate transfer to the TSR. If during a transmission the UTXEN bit is cleared, the transmission will immediately cease and the transmitter will be reset. The UTX output pin can then be configured as the I/O or other pin-shared function by configuring the corresponding pin-shared control bits.

Transmitting Data

When the UART is transmitting data, the data is shifted on the UTX pin from the shift register, with the least significant bit first. In the transmit mode, the UTXR_RXR register forms a buffer between the internal bus and the transmitter shift register. It should be noted that if 9-bit data format has been selected, then the MSB will be taken from the UTX8 bit in the UUCR1 register. The steps to initiate a data transfer can be summarized as follows:

- Make the correct selection of the UBNO, UPRT, UPREN and USTOPS bits to define the required word length, parity type and number of stop bits.
- Setup the UBRG register to select the desired baud rate.
- Set the UTXEN bit ensure that the UTX pin is used as a UART transmitter pin.
- Access the UUSR register and write the data that is to be transmitted into the UTXR_RXR register. Note that this step will clear the UTXIF bit.

This sequence of events can now be repeated to send additional data.

It should be noted that when UTXIF=0, data will be inhibited from being written to the UTXR_RXR register. Clearing the UTXIF flag is always achieved using the following software sequence:

1. A UUSR register access
2. A UTXR_RXR register write execution

The read-only UTXIF flag is set by the UART hardware and if set indicates that the UTXR_RXR register is empty and that other data can now be written into the UTXR_RXR register without overwriting the previous data. If the UTEIE bit is set then the UTXIF flag will generate an interrupt.

During a data transmission, a write instruction to the UTXR_RXR register will place the data into the UTXR_RXR register, which will be copied to the shift register at the end of the present transmission. When there is no data transmission in progress, a write instruction to the UTXR_RXR register will place the data directly into the shift register, resulting in the commencement of data transmission, and the UTXIF bit being immediately set. When a frame transmission is complete, which happens after stop bits are sent or after the break frame, the UTIDLE bit will be set. To clear the UTIDLE bit the following software sequence is used:

1. A UUSR register access
2. A UTXR_RXR register write execution

Note that both the UTXIF and UTIDLE bits are cleared by the same software sequence.

Transmitting Break

If the UTXBRK bit is set high and the state keeps for a time greater than $[(BRG+1) \times t_{H}]$ while $UTIDLE=1$, then break characters will be sent on the next transmission. Break character transmission consists of a start bit, followed by $13 \times N$ '0' bits and stop bits, where $N=1, 2$, etc. If a break character is to be transmitted then the UTXBRK bit must be first set by the application program, and then cleared to generate the stop bits. Transmitting a break character will not generate a transmit interrupt. Note that a break condition length is at least 13 bits long. If the UTXBRK bit is continually kept at a logic high level then the transmitter circuitry will transmit continuous break characters. After the application program has cleared the UTXBRK bit, the transmitter will finish transmitting the last break character and subsequently send out one or two stop bits. The automatic logic highs at the end of the last break character will ensure that the start bit of the next frame is recognized.

UART Receiver

The UART is capable of receiving word lengths of either 8 or 9 bits. If the UBNO bit is set, the word length will be set to 9 bits with the MSB being stored in the URX8 bit of the UUCR1 register. At the receiver core lies the Receive Serial Shift Register, commonly known as the RSR. The data which is received on the URX/UTX pin input is sent to the data recovery block. The data recovery block operating speed is 16 times that of the baud rate, while the main receive serial shifter operates at the baud rate. After the URX/UTX pin is sampled for the stop bit, the received data in RSR is transferred to the receive data register, if the register is empty. The data which is received on the external URX/UTX pin input is sampled three times by a majority detect circuit to determine the logic level that has been placed onto the URX/UTX pin. It should be noted that the RSR register, unlike many other registers, is not directly mapped into the Data Memory area and as such is not available to the application program for direct read/write operations.

Receiving Data

When the UART receiver is receiving data, the data is serially shifted in on the external URX/UTX pin input, LSB first. In the read mode, the UTXR_RXR register forms a buffer between the internal bus and the receiver shift register. The UTXR_RXR register is a two-byte deep FIFO data buffer, where two bytes can be held in the FIFO while a third byte can continue to be received. Note that the application program must ensure that the data is read from UTXR_RXR before the third byte has been completely shifted in, otherwise this third byte will be discarded and an overrun error UOERR will be subsequently indicated. The steps to initiate a data transfer can be summarized as follows:

- Make the correct selection of UBNO, UPRT and UPREN bits to define the word length, parity type.
- Setup the UBRG register to select the desired baud rate.
- Set the URXEN bit to ensure that the URX/UTX pin is used as a UART receiver pin.

At this point the receiver will be enabled which will begin to look for a start bit.

When a character is received the following sequence of events will occur:

- The URXIF bit in the UUSR register will be set when the UTXR_RXR register has data available. There will be at most one more character available before an overrun error occurs.
- When the contents of the shift register have been transferred to the UTXR_RXR register, then if the URIE bit is set, an interrupt will be generated.
- If during reception, a frame error, noise error, parity error, or an overrun error has been detected, then the error flags can be set.

The URXIF bit can be cleared using the following software sequence:

1. A UUSR register access
2. A UTXR_RXR register read execution

Receiving Break

Any break character received by the UART will be managed as a framing error. The receiver will count and expect a certain number of bit times as specified by the values programmed into the UBNO bit plus one stop bit. If the break is much longer than 13 bit times, the reception will be considered as complete after the number of bit times specified by UBNO plus one stop bit. The URXIF bit is set, UFERR is set, zeros are loaded into the receive data register, interrupts are generated if appropriate and the URIDLE bit is set. A break is regarded as a character that contains only zeros with the UFERR flag set. If a long break signal has been detected, the receiver will regard it as a data frame including a start bit, data bits and the invalid stop bit and the UFERR flag will be set. The receiver must wait for a valid stop bit before looking for the next start bit. The receiver will not make the assumption that the break condition on the line is the next start bit. The break character will be loaded into the buffer and no further data will be received until stop bits are received. It should be noted that the URIDLE read only flag will go high when the stop bits have not yet been received. The reception of a break character on the UART registers will result in the following:

- The framing error flag, UFERR, will be set.
- The receive data register, UTXR_RXR, will be cleared.
- The UOERR, UNF, UPERR, URIDLE or URXIF flags will possibly be set.

Idle Status

When the receiver is reading data, which means it will be in between the detection of a start bit and the reading of a stop bit, the receiver status flag in the UUSR register, otherwise known as the URIDLE flag, will have a zero value. In between the reception of a stop bit and the detection of the next start bit, the URIDLE flag will have a high value, which indicates the receiver is in an idle condition.

Receiver Interrupt

The read only receive interrupt flag URXIF in the UUSR register is set by an edge generated by the receiver. An interrupt is generated if URIE=1, when a word is transferred from the Receive Shift Register, RSR, to the Receive Data Register, UTXR_RXR. An overrun error can also generate an interrupt if URIE=1.

Managing Receiver Errors

Several types of reception errors can occur within the UART module, the following section describes the various types and how they are managed by the UART.

Overrun Error – UOERR

The UTXR_RXR register is composed of a two-byte deep FIFO data buffer, where two bytes can be held in the FIFO register, while a third byte can continue to be received. Before this third byte has been entirely shifted in, the data should be read from the UTXR_RXR register. If this is not done, the overrun error flag UOERR will be consequently indicated.

In the event of an overrun error occurring, the following will happen:

- The UOERR flag in the UUSR register will be set.
- The UTXR_RXR contents will not be lost.
- The shift register will be overwritten.
- An interrupt will be generated if the URIE bit is set.

The UOERR flag can be cleared by an access to the UUSR register followed by a read to the UTXR_RXR register.

Noise Error – UNF

Over-sampling is used for data recovery to identify valid incoming data and noise. If noise is detected within a frame the following will occur:

- The read only noise flag, UNF, in the UUSR register will be set on the rising edge of the URXIF bit.
- Data will be transferred from the Shift register to the UTXR_RXR register.
- No interrupt will be generated. However this bit rises at the same time as the URXIF bit which itself generates an interrupt.

Note that the UNF flag is reset by a UUSR register read operation followed by a UTXR_RXR register read operation.

Framing Error – UFERR

The read only framing error flag, UFERR, in the UUSR register, is set if a zero is detected instead of stop bits. If two stop bits are selected, both stop bits must be high; otherwise the UFERR flag will be set. The UFERR flag and the received data will be recorded in the UUSR and UTXR_RXR registers respectively, and the flag is cleared in any reset.

Parity Error – UPERR

The read only parity error flag, UPERR, in the UUSR register, is set if the parity of the received word is incorrect. This error flag is only applicable if the parity is enabled, UPREN=1, and if the parity type, odd or even is selected. The read only UPERR flag and the received data will be recorded in the UUSR and UTXR_RXR registers respectively. It is cleared on any reset, it should be noted that the flags, UFERR and UPERR, in the UUSR register should first be read by the application program before reading the data word.

UART Interrupt Structure

Several individual UART conditions can trigger an USIM interrupt. When these conditions exist, a low pulse will be generated to get the attention of the microcontroller. These conditions are a transmitter data register empty, transmitter idle, receiver data available, receiver overrun, address detect and an URX/UTX pin wake-up. When any of these conditions are created, if the global interrupt enable bit and the USIM interrupt control bit are enabled and the stack is not full, the program will jump to its corresponding interrupt vector where it can be serviced before returning to the main program. Four of these conditions have the corresponding UUSR register flags which will generate an USIM interrupt if its associated interrupt enable control bit in the UUCR2 register is set. The two transmitter interrupt conditions have their own corresponding enable control bits, while the two receiver interrupt conditions have a shared enable control bit. These enable bits can be used to mask out individual USIM UART mode interrupt sources.

The address detect condition, which is also an USIM UART mode interrupt source, does not have an associated flag, but will generate an USIM interrupt when an address detect condition occurs if its function is enabled by setting the UADDEN bit in the UUCR2 register. An URX/UTX pin wake-up, which is also an USIM UART mode interrupt source, does not have an associated flag, but will generate an USIM interrupt if the UART clock (f_H) source is switched off and the UWAKE and URIE bits in the UUCR2 register are set when a falling edge on the URX/UTX pin occurs. Note that in the event of an URX/UTX wake-up interrupt occurring, there will be a certain period of delay, commonly known as the System Start-up Time, for the oscillator to restart and stabilize before the system resumes normal operation.

Note that the UUSR register flags are read only and cannot be cleared or set by the application program, neither will they be cleared when the program jumps to the corresponding interrupt

servicing routine, as is the case for some of the other interrupts. The flags will be cleared automatically when certain actions are taken by the UART, the details of which are given in the UART register section. The overall UART interrupt can be disabled or enabled by the USIM interrupt enable control bit in the interrupt control register of the microcontroller to decide whether the interrupt requested by the UART module is masked out or allowed.

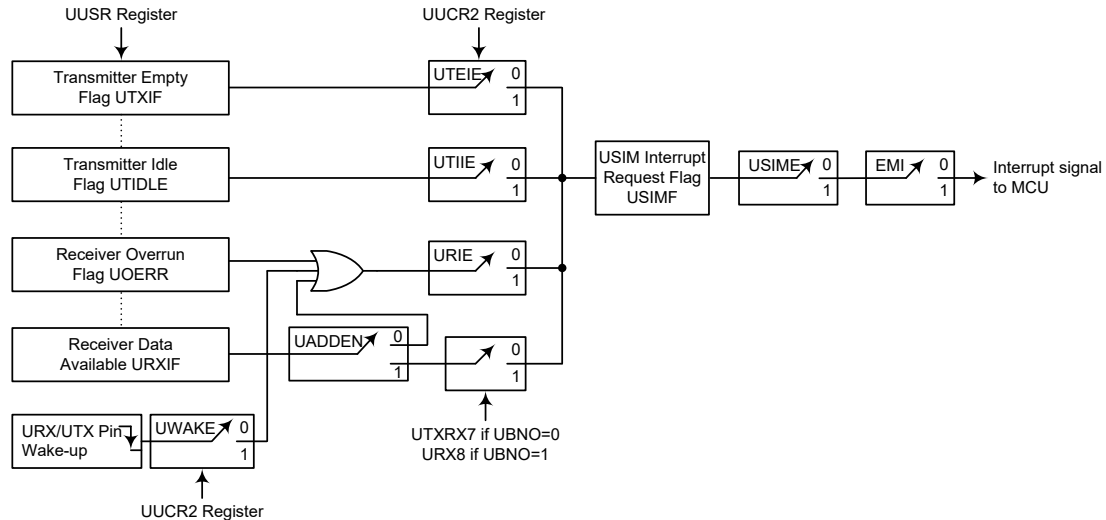

UART Interrupt Structure

Address Detect Mode

Setting the Address Detect Mode bit, UADDEEN, in the UUCR2 register, enables this special mode. If this bit is enabled then an additional qualifier will be placed on the generation of a Receiver Data Available interrupt, which is requested by the URXIF flag. If the UADDEEN bit is enabled, then when data is available, an interrupt will only be generated if the highest received bit has a high value. Note that the USIME and EMI interrupt enable bits must also be enabled for correct interrupt generation. This highest address bit is the 9th bit if UBNO=1 or the 8th bit if UBNO=0. If this bit is high, then the received word will be defined as an address rather than data. A Data Available interrupt will be generated every time the last bit of the received word is set. If the UADDEEN bit is not enabled, then a Receiver Data Available interrupt will be generated each time the URXIF flag is set, irrespective of the data last bit status. The address detect mode and parity enable are mutually exclusive functions. Therefore if the address detect mode is enabled, then to ensure correct operation, the parity function should be disabled by resetting the parity enable bit UPREN to zero.

UADDEEN	9th Bit if UBNO=1, 8th Bit if UBNO=0	USIM Interrupt Generated
0	0	√
	1	√
1	0	×
	1	√

UADDEEN Bit Function

UART Power Down and Wake-up

When the UART clock (f_{H}) is off, the UART will cease to function, all clock sources to the module are shutdown. If the UART clock (f_{H}) is off while a transmission is still in progress, then the transmission will be paused until the UART clock source derived from the microcontroller is activated. In a similar way, if the MCU enters the IDLE or SLEEP mode while receiving data, then

the reception of data will likewise be paused. When the MCU enters the IDLE or SLEEP mode, note that the UUSR, UUCR1, UUCR2, UUCR3, UTXR_RXR, as well as the UBRG register will not be affected. It is recommended to make sure first that the UART data transmission or reception has been finished before the microcontroller enters the IDLE or SLEEP mode.

The UART function contains a receiver URX/UTX pin wake-up function, which is enabled or disabled by the UWAKE bit in the UUCR2 register. If this bit, along with the UART mode selection bit, UMD, the UART enable bit, UREN, the receiver enable bit, URXEN and the receiver interrupt bit, URIE, are all set when the UART clock (f_{H}) is off, then a falling edge on the URX/UTX pin will trigger an URX/UTX pin wake-up UART interrupt. Note that as it takes certain system clock cycles after a wake-up, before normal microcontroller operation resumes, any data received during this time on the URX/UTX pin will be ignored.

For a UART wake-up interrupt to occur, in addition to the bits for the wake-up being set, the global interrupt enable bit, EMI, and the USIM interrupt enable bit, USIME, must be set. If the EMI and USIME bits are not set then only a wake up event will occur and no interrupt will be generated. Note also that as it takes certain system clock cycles after a wake-up before normal microcontroller resumes, the USIM interrupt will not be generated until after this time has elapsed.

LCD Driver

For large volume applications, which incorporate an LCD in their design, the use of a custom display rather than a more expensive character based display reduces costs significantly. However, the corresponding COM and SEG signals required, which vary in both amplitude and time, to drive such a custom display require many special considerations for proper LCD operation to occur.

These devices contain an LCD Driver function, which with their internal LCD signal generating circuitry and various options will automatically generate these time and amplitude varying signals to provide a means of direct driving and easy interfacing to a range of custom LCDs.

These devices include a wide range of options to enable LCD displays of various types to be driven. The table shows the range of options available across the devices range

Device	Driver No.	Duty	Bias	Bias Type	Wave Type
HT67L2540A	24×4	1/4	1/3	R or C type	A or B
HT67L2550A	32×4	1/4	1/3	R or C type	A or B

LCD Driver Output Selection

LCD Display Memory

An area of Data Memory is especially reserved for use for the LCD display data. This data area is known as the LCD Memory. Any data written here will be automatically read by the internal display driver circuits, which will in turn automatically generate the necessary LCD driving signals. Therefore any data written into this Memory will be immediately reflected into the actual display connected to the microcontroller.

These devices provide an area of embedded data memory for the LCD display. This area is located at 00H to 17H or 00H to 1FH in Sector 4 of the Data Memory respectively. If using the indirect addressing to access the Display Memory therefore requires first that Sector 4 is selected by writing a value of 04H to MP1H or MP2H. After this, the memory can then be accessed by using indirect addressing through the use of MP1L or MP2L. With Sector 4 selected, then using MP1L/MP2L to read or write to the memory area, from 00H to 17H or 00H to 1FH, will result in operations to the LCD memory. Directly addressing the Display Memory can only be implemented using the extended instructions

When data is written into the display data area, it is automatically read by the LCD driver which

then generates the corresponding LCD driving signals. To turn the display on or off, a “1” or a “0” is written to the corresponding bit of the display memory, respectively. The figure illustrates the mapping between the display memory and LCD pattern for the device.

The unimplemented LCD RAM bits cannot be used as general purpose RAM for application. For example, if the LCD duty is selected as 1/4 duty (4COM), the COM b4~b7 will be read as 0 only.

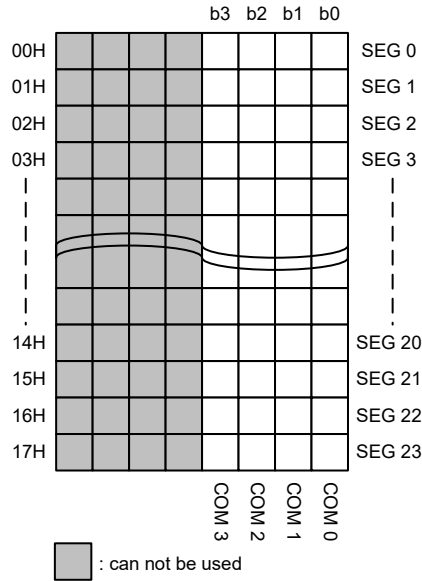

LCD Memory Map – HT67L2540A

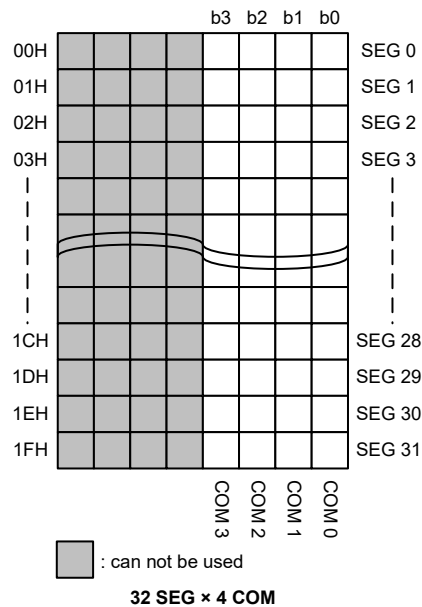

LCD Memory Map – HT67L2550A

LCD Clock Source

The LCD clock source is the internal clock signal, f_{LCD} , divided by 8 using an internal divider circuit. The f_{LCD} internal clock is sourced from either the LIRC or LXT oscillator, selected via configuring the FSS bit in the SCC register. For proper LCD operation, this arrangement is provided to generate an ideal LCD clock source frequency of 4kHz.

f_{LCD} Clock Source	LCD Clock Frequency
LIRC	4kHz
LXT	4kHz

LCD Clock Source

C-type LCD Pump Clock Source

The C-type LCD pump clock source, f_{LCDP} , is provided by either the LIRC or LXT oscillator clock source, f_{LXT} or f_{LIRC} , selected via configuring the FSS bit in the SCC register. The f_{LXT} or f_{LIRC} is divided by a factor of 1, 2, 4 or 8 using an internal divider circuit. The actual division factor is determined using the LCDPCK[2:0] bits in the LCDC2 register.

LCDPCK[2:0] Bits	f_{LCDP}	Frequency
000~011	$f_{LXT}/8$ or $f_{LIRC}/8$	4kHz
100	$f_{LXT}/4$ or $f_{LIRC}/4$	8kHz
101	$f_{LXT}/2$ or $f_{LIRC}/2$	16kHz
110~111	f_{LXT} or f_{LIRC}	32kHz

LCD Registers

Control Registers in the Data Memory, are used to control the various setup features of the LCD Driver. There are several control registers for the LCD function, LCDC0, LCDC1 and LCDC2.

The TYPE bit in the LCDC0 register is used to select whether Type A or Type B LCD waveform signals are used. The RCT bit is used to select whether R type or C type LCD drive bias. Bits LCDP1 and LCDP0 are used to select that the LCD supply power comes from either the external pin or internal power supply for C type bias application. The RSEL[2:0] bits are used to select the internal total bias resistors to supply the LCD panel with the proper bias current. A choice to best match the LCD panel used in the application can be selected also to minimise bias current. The LCDEN bit, which provides the overall LCD enable/disable function, will be effective no matter which mode the device is in.

The PLCD3~PLCD0 bits in the LCDC1 register are used to select the V_A voltage for R type bias circuitry. The QCT2~QCT0 bits in the same register are used to determine the quick charging time period.

The LCDC2 register is used to select the C-type LCD pump clock divider value.

Register Name	Bit							
	7	6	5	4	3	2	1	0
LCDC0	TYPE	RCT	LCDP1	LCDP0	RSEL2	RSEL1	RSEL0	LCDEN
LCDC1	QCT2	QCT1	QCT0	—	PLCD3	PLCD2	PLCD1	PLCD0
LCDC2	—	—	—	—	—	LCDPCK2	LCDPCK1	LCDPCK0

LCD Register List

• **LCDC0 Register**

Bit	7	6	5	4	3	2	1	0
Name	TYPE	RCT	LCDP1	LCDP0	RSEL2	RSEL1	RSEL0	LCDEN
R/W	R/W	R/W	R/W	R/W	R/W	R/W	R/W	R/W
POR	0	0	0	0	0	0	0	0

Bit 7 **TYPE**: LCD Waveform Type selection

0: Type A
1: Type B

Bit 6 **RCT**: R or C LCD bias type selection

0: R type
1: C type

When this bit is clear to 0, the LCDP[1:0] bits should be fixed at “00” and the power source is from the PLCD pin.

Bit 5~4 **LCDP1~LCDP0**: C type bias LCD power source selection

00: From external pin PLCD, V1 or V2
01: From internal reference voltage V_{REFIN} supplied to V_C
10: From internal voltage V_{DD} supplied to V_B
11: From internal voltage V_{DD} supplied to V_A

The V_{REFIN} is an internal reference voltage with an approximate level of 1.04V

Bit 3~1 **RSEL2~RSEL0**: R type bias LCD total bias resistors (R_T) selection

000: 1170k Ω
001: 225k Ω
010: 60k Ω
011: Quick charging mode – switching between 60k Ω and 1170k Ω
1xx: Quick charging mode – switching between 60k Ω and 225k Ω

The bias resistor for 1/3 bias is $R_T/3$. The devices provide the low power quick charging mode for R type bias LCD display. In quick charging mode, the LCD will provide more bias current with 60k Ω R_T used at the beginning of each COMn phase as LCD display refreshes and then provide less bias current with 1170k Ω or 225k Ω R_T used to reduce the bias current consumption in the remaining time duration in the same COMn phase.

Bit 0 **LCDEN**: LCD enable control

0: Disable
1: Enable

Whatever the device is in any mode, the LCD on/off function can be controlled by this bit.

• **LCDC1 Register**

Bit	7	6	5	4	3	2	1	0
Name	QCT2	QCT1	QCT0	—	PLCD3	PLCD2	PLCD1	PLCD0
R/W	R/W	R/W	R/W	—	R/W	R/W	R/W	R/W
POR	0	0	0	—	0	0	0	0

Bit 7~5 **QCT2~QCT0**: R type quick charging time selection

000: 1 t_{LCD}
001: 2 t_{LCD}
010: 3 t_{LCD}
011: 4 t_{LCD}
100: 5 t_{LCD}
101: 6 t_{LCD}
110: 7 t_{LCD}
111: 8 t_{LCD}

The t_{LCD} is the period of the LCD clock source f_{LCD} , i.e., $1/f_{LCD}$.

- Bit 4 Unimplemented, read as “0”
- Bit 3~0 **PLCD3~PLCD0**: R type bias supply voltage selection for V_A
- 0000: $8/16 \times V_{PLCD}$
 - 0001: $9/16 \times V_{PLCD}$
 - 0010: $10/16 \times V_{PLCD}$
 - 0011: $11/16 \times V_{PLCD}$
 - 0100: $12/16 \times V_{PLCD}$
 - 0101: $13/16 \times V_{PLCD}$
 - 0110: $14/16 \times V_{PLCD}$
 - 0111: $15/16 \times V_{PLCD}$
 - 1XXX: V_{PLCD}

Note that the V_A voltage level must be equal to or greater than 2.1V.

• **LCDC2 Register**

Bit	7	6	5	4	3	2	1	0
Name	—	—	—	—	—	LCDPCK2	LCDPCK1	LCDPCK0
R/W	—	—	—	—	—	R/W	R/W	R/W
POR	—	—	—	—	—	0	0	0

- Bit 7~3 Unimplemented, read as “0”
- Bit 2~0 **LCDPCK2~LCDPCK0**: C type LCD pump clock divider selection
- 000: 250Hz ($f_{LCDP}/16$, $f_{LCDP}=4\text{kHz}$)
 - 001: 500Hz ($f_{LCDP}/8$, $f_{LCDP}=4\text{kHz}$)
 - 010: 1kHz ($f_{LCDP}/4$, $f_{LCDP}=4\text{kHz}$)
 - 011: 2kHz ($f_{LCDP}/2$, $f_{LCDP}=4\text{kHz}$)
 - 100: 4kHz ($f_{LCDP}/2$, $f_{LCDP}=8\text{kHz}$)
 - 101: 8kHz ($f_{LCDP}/2$, $f_{LCDP}=16\text{kHz}$)
 - 110: 16kHz ($f_{LCDP}/2$, $f_{LCDP}=32\text{kHz}$)
 - 111: 16kHz ($f_{LCDP}/2$, $f_{LCDP}=32\text{kHz}$)

LCD Voltage Source and Biasing

The time and amplitude varying signals generated by the LCD Driver function require the generation of several voltage levels for their operation. The device can have either R type or C type biasing selected via a software control bit RCT. Selecting the C type biasing will enable C type internal charge pump circuitry.

R Type Biasing

For R type biasing an external LCD voltage source must be supplied on pin PLCD to generate the internal biasing voltages. This could be the microcontroller power supply V_{DD} or some other voltage source equal to or less than V_{DD} . For the R type 1/3 bias scheme, four voltage levels V_{SS} , V_A , V_B and V_C are utilised. The voltage V_A which is selected by the PLCD3~PLCD0 bits in the LCDC1 register can be equal to a specific ratio of PLCD voltage, varying from $8/16 V_{PLCD}$ to V_{PLCD} . The voltage V_B is equal to $V_A \times 2/3$ while the voltage V_C is equal to $V_A \times 1/3$.

Different values of internal bias resistors can be selected using the RSEL2~RSEL0 bits in the LCDC0 register. This along with the voltage on pin PLCD will determine the bias current. The VMAX pin should be connected to the VDD pin since the available maximum voltage applied to the PLCD pin is equal to V_{DD} .

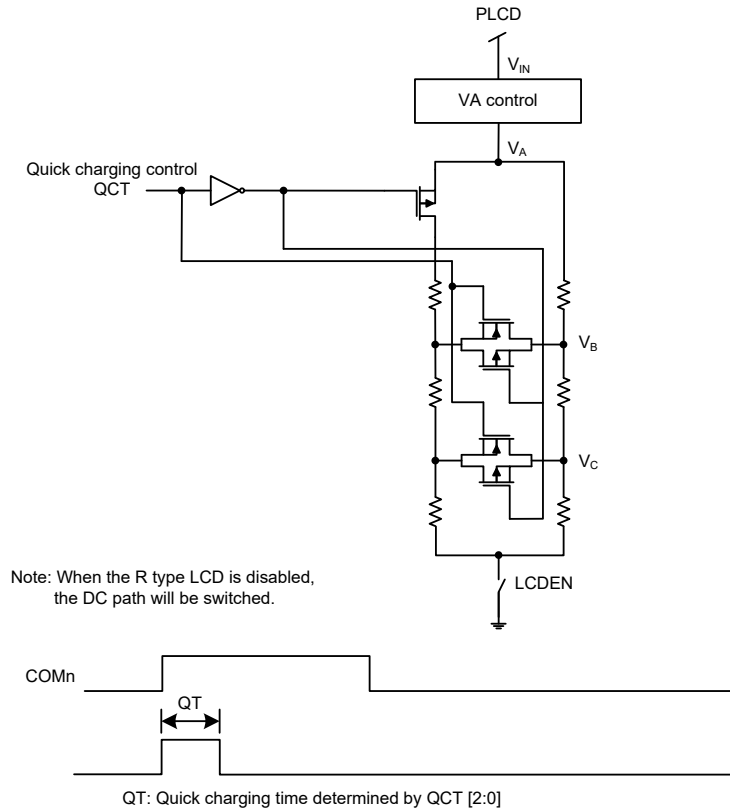

R Type Bias Configuration – 1/3 Bias

C Type Biasing

For C type biasing the LCD voltage source can be supplied on the external pin PLCD, V1 or V2 or can be derived from the internal power source to generate the required biasing voltages. The C type bias voltage source is selected using the LCDP1~LCDP0 bits in the LCDC0 register.

When the LCD voltage source is from the PLCD or V2 pin, the C type biasing scheme uses an internal charge pump circuit, which can generate voltages higher than what is supplied on PLCD or V2. This feature is useful in applications where the microcontroller supply voltage is less than the supply voltage required by the LCD. An additional charge pump capacitor must also be connected between pins C1 and C2 to generate the necessary voltage levels.

For C type 1/3 bias scheme and whether the LCD power is selected from external pin or internal voltage, four voltage levels V_{SS} , V_A , V_B and V_C are utilised. These bias voltages have different levels depending upon different LCD power supply schemes.

LCD Power Supply		V_A Voltage	V_B Voltage	V_C Voltage
External Power Supply	V_{IN} from V1 pin	V_{IN}	$2/3 \times V_{IN}$	$1/3 \times V_{IN}$
	V_{IN} from PLCD pin	$3/2 \times V_{IN}$	V_{IN}	$1/2 \times V_{IN}$
	V_{IN} from V2 pin	$3 \times V_{IN}$	$2 \times V_{IN}$	V_{IN}
Internal Power Supply	V_A ($V_A=V_{DD}$)	V_{DD}	$2/3 \times V_{DD}$	$1/3 \times V_{DD}$
	V_B ($V_B=V_{DD}$)	$3/2 \times V_{DD}$	V_{DD}	$1/2 \times V_{DD}$
	V_C ($V_C=V_{REFIN}$) ^{Note}	$3 \times V_{REFIN}$	$2 \times V_{REFIN}$	V_{REFIN}

Note: The V_{REFIN} voltage is from the devices ingerated depletion circuit and has an approximate level of 1.04V.

C Type Bias Power Supply Scheme

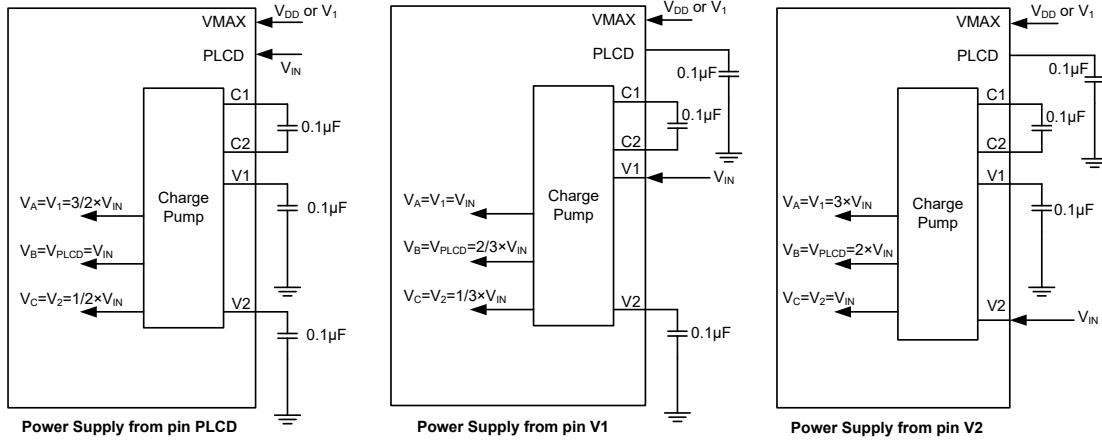

Note: The pin VMAX must be connected to the maximum voltage to prevent from the pad leakage.

C Type Bias External Power Supply Configuration – 1/3 Bias

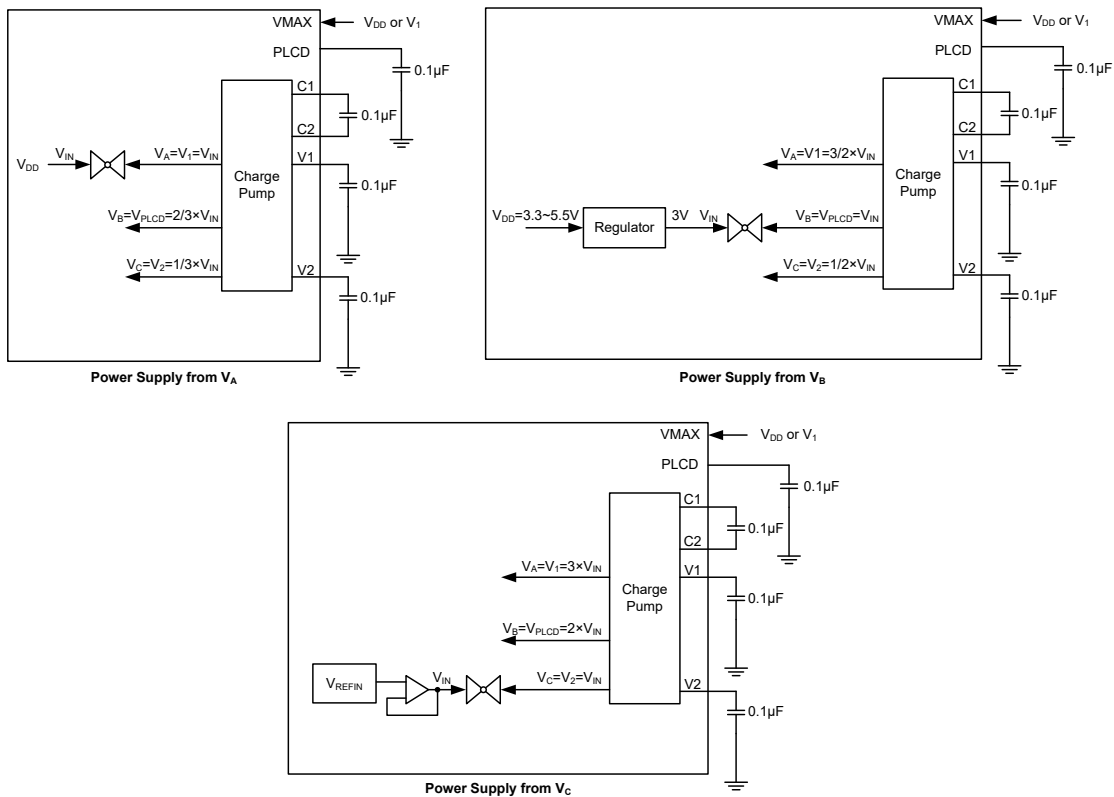

Note: The pin VMAX must be connected to the maximum voltage to prevent from the pad leakage.

C Type Bias Internal Power Supply Configuration – 1/3 Bias

The connection to the VMAX pin depends upon the LCD power supply scheme. The details are shown in the table. It is extremely important to ensure that these charge pump generated internal voltages do not exceed the maximum V_{DD} voltage of 5.5V.

Condition	VMAX Connection
V _{DD} > V _{PLCD} × 1.5	Connect VMAX to VDD
Otherwise	Connect VMAX to V1

C Type Bias VMAX Pin Connection

LCD Reset Status

The LCD has an internal reset function. Clearing the LCDEN bit to zero will reset the LCD function. When the LCDEN bit is set to “1” to enable the LCD driver and then an MCU reset occurs, the LCD driver will be reset and the COM and SEG output will be in a floating state during the MCU reset duration. The reset operation will take a time of t_{RSTD}+t_{SST}. Refer to the System Start Up Time Characteristics for t_{RSTD} and t_{SST} details.

MCU Reset	LCDEN	LCD Reset	COM and SEG Voltage Level
No	1	No	Normal Operation
No	0	Yes	Low
Yes	x	Yes	Floating

Note: 1. The watchdog time-out reset in the IDLE or SLEEP Mode is excluded from the MCU Reset conditions.

2. “x”: Don’t care.

LCD Reset Status

LCD Driver Output

The number of COM and SEG outputs supplied by the LCD driver, as well as its biasing and wave type selections, are dependent upon how the LCD control bits are programmed. The Bias Type, whether C or R type is also selected by a software control bit.

The nature of Liquid Crystal Displays requires that only AC voltages can be applied to their pixels as the application of DC voltages to LCD pixels may cause permanent damage. For this reason the relative contrast of an LCD display is controlled by the actual RMS voltage applied to each pixel, which is equal to the RMS value of the voltage on the COM pin minus the voltage applied to the SEG pin. This differential RMS voltage must be greater than the LCD saturation voltage for the pixel to be on and less than the threshold voltage for the pixel to be off.

The requirement to limit the DC voltage to zero and to control as many pixels as possible with a minimum number of connections requires that both a time and amplitude signal is generated and applied to the application LCD. These time and amplitude varying signals are automatically generated by the LCD driver circuits in the microcontroller. What is known as the duty determines the number of common lines used, which are also known as backplanes or COMs. The duty, which is to have a value of 1/4 and which equates to a COM number of 4, therefore defines the number of time divisions within each LCD signal frame. Two types of signal generation are also provided, known as Type A and Type B, the required type is selected via the TYPE bit in the LCDC0 register. Type B offers lower frequency signals, however, lower frequencies may introduce flickering and influence display clarity.

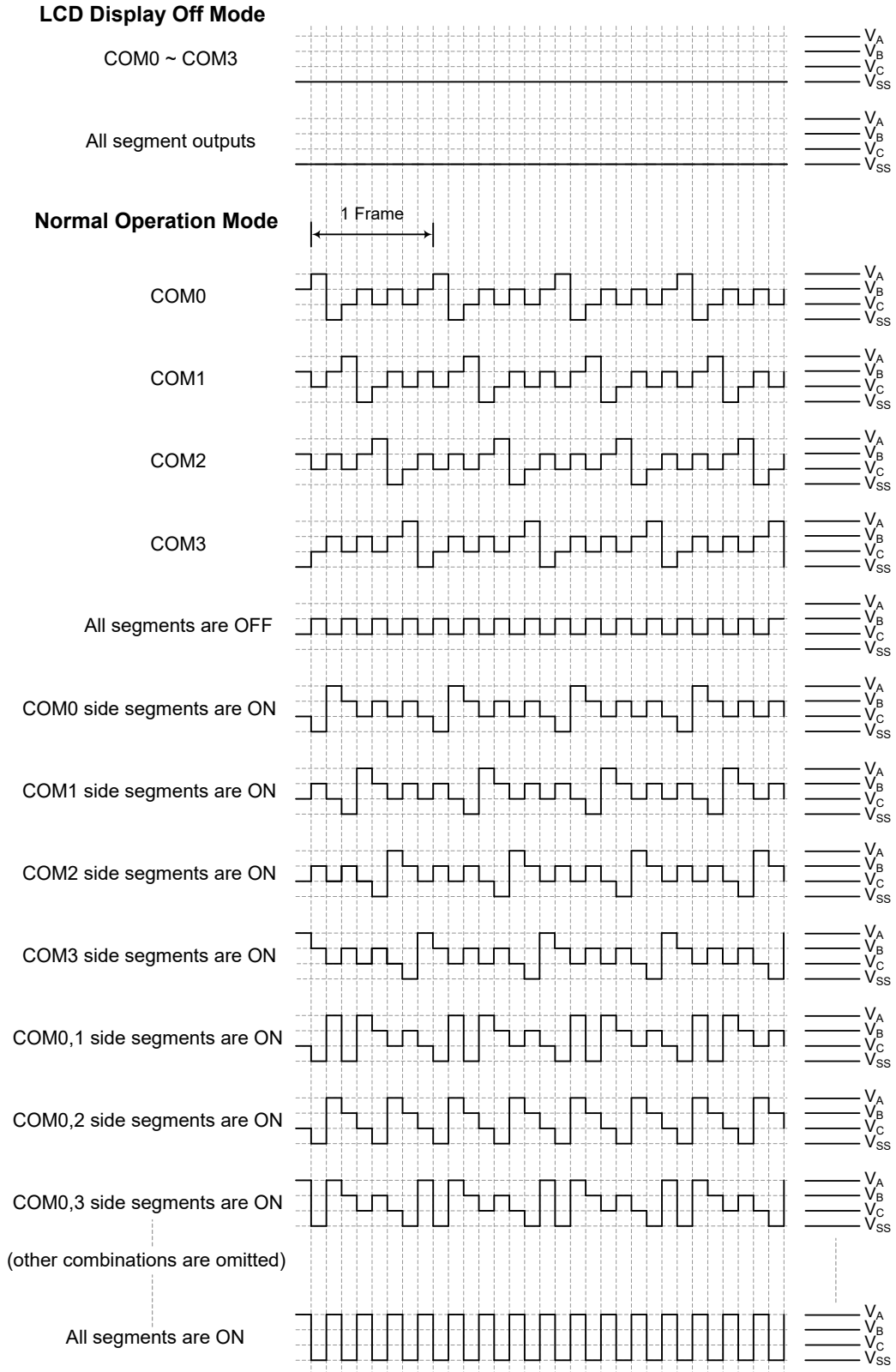

LCD Driver Output – Type A, 1/4 duty, 1/3 bias

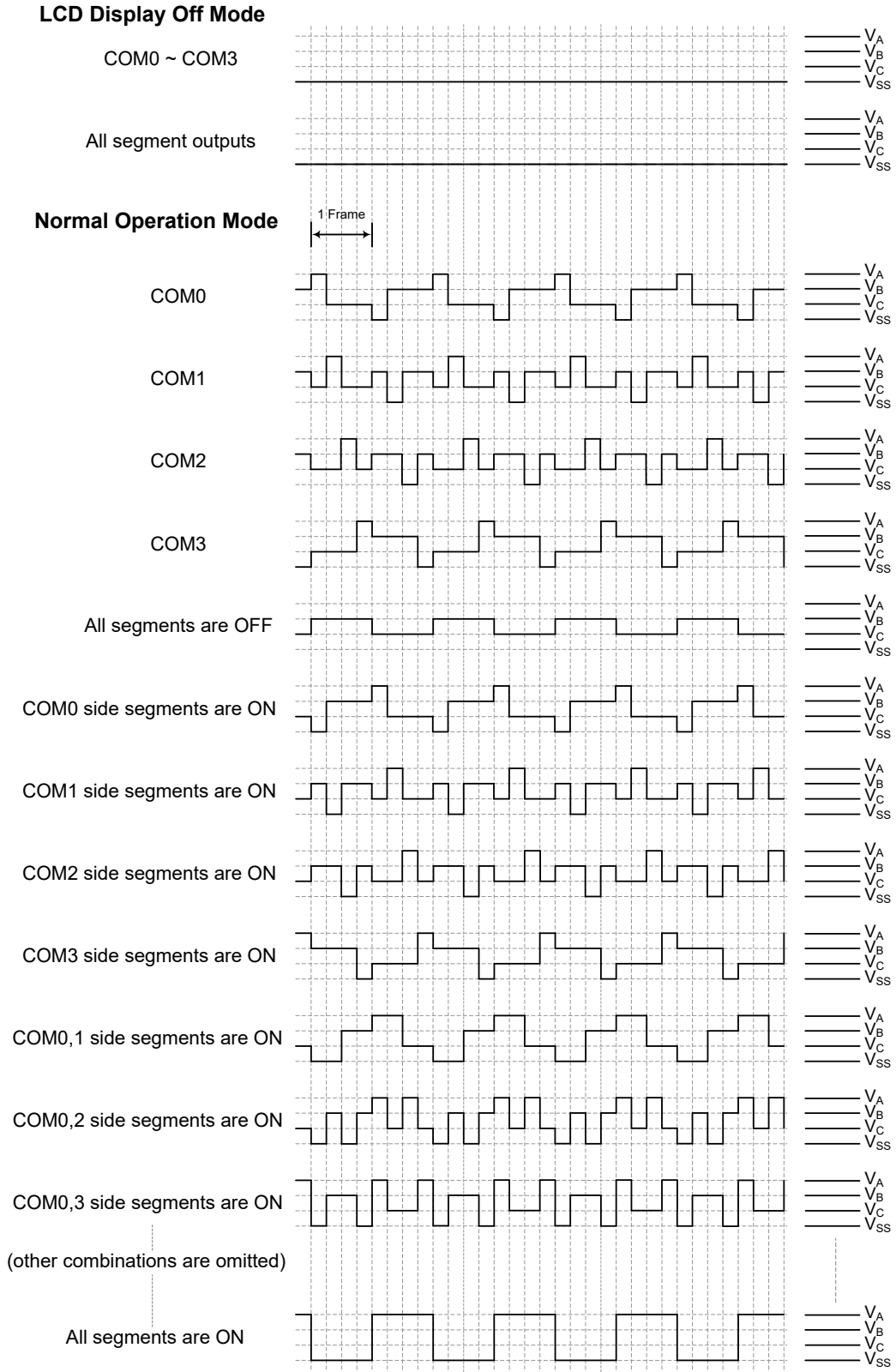

LCD Driver Output – Type B, 1/4 duty, 1/3 bias

Programming Considerations

Certain precautions must be taken when programming the LCD. One of these is to ensure that the LCD Memory is properly initialised after the microcontroller is powered on. Like the General Purpose Data Memory, the contents of the LCD Memory are in an unknown condition after power-on. As the contents of the LCD Memory will be mapped into the actual display, it is important to initialise this memory area into a known condition soon after applying power to obtain a proper display pattern.

Consideration must also be given to the capacitive load of the actual LCD used in the application. As the load presented to the microcontroller by LCD pixels can be generally modeled as mainly capacitive in nature, it is important that this is not excessive, a point that is particularly true in the case of the COM lines which may be connected to many LCD pixels. The accompanying diagram depicts the equivalent circuit of the LCD.

One additional consideration that must be taken into account is what happens when the microcontroller enters the IDLE or SLOW Mode. The LCDEN control bit in the LCDC0 register permits the display to be powered off to reduce power consumption. If this bit is zero, the driving signals to the display will cease, producing a blank display pattern but reducing any power consumption associated with the LCD.

After Power-on, note that as the LCDEN bit will be cleared to zero, the display function will be disabled.

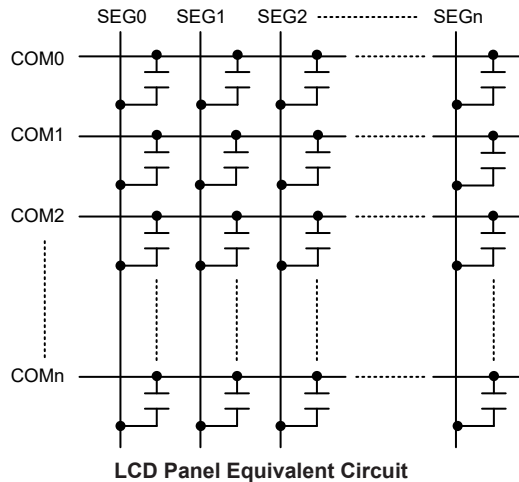

Cyclic Redundancy Check – CRC

The Cyclic Redundancy Check, CRC, calculation unit is an error detection technique test algorithm and uses to verify data transmission or storage data correctness. A CRC calculation takes a data stream or a block of data as input and generates a 16-bit output remainder. Ordinarily, a data stream is suffixed by a CRC code and used as a checksum when being sent or stored. Therefore, the received or restored data stream is calculated by the same generator polynomial as described in the following section.

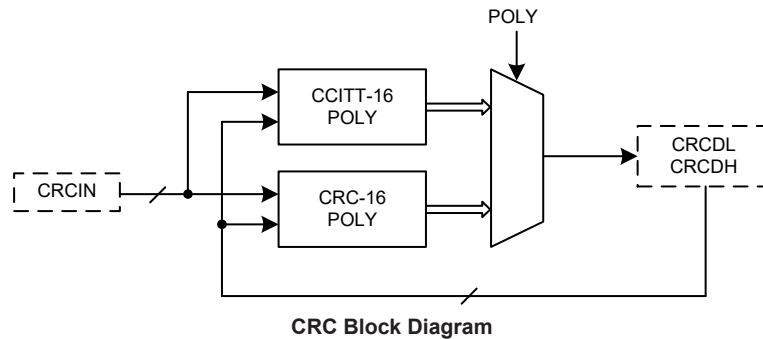

CRC Registers

The CRC generator contains an 8-bit CRC data input register, CRCIN, and a CRC checksum register pair, CRCDH and CRCDL. The CRCIN register is used to input new data and the CRCDH and CRCDL registers are used to hold the previous CRC calculation result. A CRC control register, CRCCR, is used to select which CRC generating polynomial is used.

Register Name	Bit							
	7	6	5	4	3	2	1	0
CRCIN	D7	D6	D5	D4	D3	D2	D1	D0
CRCDL	D7	D6	D5	D4	D3	D2	D1	D0
CRCDH	D15	D14	D13	D12	D11	D10	D9	D8
CRCCR	—	—	—	—	—	—	—	POLY

CRC Register List

• CRCIN Register

Bit	7	6	5	4	3	2	1	0
Name	D7	D6	D5	D4	D3	D2	D1	D0
R/W	R/W	R/W	R/W	R/W	R/W	R/W	R/W	R/W
POR	0	0	0	0	0	0	0	0

Bit 7~0 **D7~D0**: CRC input data register

• CRCDL Register

Bit	7	6	5	4	3	2	1	0
Name	D7	D6	D5	D4	D3	D2	D1	D0
R/W	R/W	R/W	R/W	R/W	R/W	R/W	R/W	R/W
POR	0	0	0	0	0	0	0	0

Bit 7~0 **D7~D0**: 16-bit CRC checksum low byte data register

• **CRCDH Register**

Bit	7	6	5	4	3	2	1	0
Name	D15	D14	D13	D12	D11	D10	D9	D8
R/W	R/W	R/W	R/W	R/W	R/W	R/W	R/W	R/W
POR	0	0	0	0	0	0	0	0

Bit 7~0 **D15~D8**: 16-bit CRC checksum high byte data register

• **CRCCR Register**

Bit	7	6	5	4	3	2	1	0
Name	—	—	—	—	—	—	—	POLY
R/W	—	—	—	—	—	—	—	R/W
POR	—	—	—	—	—	—	—	0

Bit 7~1 Unimplemented, read as “0”

Bit 0 **POLY**: 16-bit CRC generating polynomial selection

0: CRC-CCITT: $X^{16} + X^{12} + X^5 + 1$

1: CRC-16: $X^{16} + X^{15} + X^2 + 1$

CRC Operation

The CRC generator provides the 16-bit CRC result calculation based on the CRC16 and CCITT CRC16 polynomials. In this CRC generator, there are only these two polynomials available for the numeric values calculation. It can not support the 16-bit CRC calculations based on any other polynomials.

The following two expressions can be used for the CRC generating polynomial which is determined using the POLY bit in the CRC control register, CRCCR. The CRC calculation result is called as the CRC checksum, CRCSUM, and stored in the CRC checksum register pair, CRCDH and CRCDL.

- CRC-CCITT: $X^{16} + X^{12} + X^5 + 1$
- CRC-16: $X^{16} + X^{15} + X^2 + 1$

CRC Computation

Each write operation to the CRCIN register creates a combination of the previous CRC value stored in the CRCDH and CRCDL registers and the new data input. The CRC unit calculates the CRC data register value is based on byte by byte. It will take one MCU instruction cycle to calculate the CRC checksum.

CRC Calculation Procedures:

1. Clear the checksum register pair, CRCDH and CRCDL.
2. Execute an “Exclusive OR” operation with the 8-bit input data byte and the 16-bit CRCSUM high byte. The result is called the temporary CRCSUM.
3. Shift the temporary CRCSUM value left by one bit and move a “0” into the LSB.
4. Check the shifted temporary CRCSUM value after procedure 3.

If the MSB is 0, then this shifted temporary CRCSUM will be considered as a new temporary CRCSUM. Otherwise, execute an “Exclusive OR” operation with the shifted temporary CRCSUM in procedure 3 and a data “8005H”. Then the operation result will be regarded as the new temporary CRCSUM.

Note that the data to be perform an “Exclusive OR” operation is “8005H” for the CRC-16 polynomial while for the CRC-CCITT polynomial the data is “1021H”.

5. Repeat the procedure 3 ~ procedure 4 until all bits of the input data byte are completely calculated.
6. Repeat the procedure 2 ~ procedure 5 until all of the input data bytes are completely calculated. Then, the latest calculated result is the final CRC checksum, CRCSUM.

CRC Calculation Examples:

- Write 1 byte input data into the CRCIN register and the corresponding CRC checksum are individually calculated as the following table shown.

CRC Data Input / CRC Polynomial	00H	01H	02H	03H	04H	05H	06H	07H
CRC-CCITT ($X^{16}+X^{12}+X^5+1$)	0000H	1021H	2042H	3063H	4084H	50A5H	60C6H	70E7H
CRC-16 ($X^{16}+X^{15}+X^2+1$)	0000H	8005H	800FH	000AH	801BH	001EH	0014H	8011H

Note: The initial value of the CRC checksum register pair, CRCDH and CRCDL, is zero before each CRC input data is written into the CRCIN register.

- Write 4 bytes input data into the CRCIN register sequentially and the CRC checksum are sequentially listed in the following table.

CRC Data Input / CRC Polynomial	CRCIN=78h→56h→34h→12h
CRC-CCITT ($X^{16}+X^{12}+X^5+1$)	(CRCDH, CRCDL)=FF9FH→BBC3H→A367H→D0FAH
CRC-16 ($X^{16}+X^{15}+X^2+1$)	(CRCDH, CRCDL)=0110h→91F1h→F2DEh→5C43h

Note: The initial value of the CRC checksum register pair, CRCDH and CRCDL, is zero before the sequential CRC data input operation.

Program Memory CRC Checksum Calculation Example:

1. Clear the checksum register pair, CRCDH and CRCDL.
2. Select the CRC-CCITT or CRC-16 polynomial as the generating polynomial using the POLY bit in the CRCCR register.
3. Execute the table read instruction to read the program memory data value.
4. Write the table data low byte into the CRCIN register and execute the CRC calculation with the current CRCSUM value. Then a new CRCSUM result will be obtained and stored in the CRC checksum register pair, CRCDH and CRCDL.
5. Write the table data high byte into the CRCIN register and execute the CRC calculation with the current CRCSUM value. Then a new CRCSUM result will be obtained and stored in the CRC checksum register pair, CRCDH and CRCDL.
6. Repeat the procedure 3 ~ procedure 5 to read the next program memory data value and execute the CRC calculation until all program memory data are read followed by the sequential CRC calculation. Then the value in the CRC checksum register pair is the final CRC calculation result.

Low Voltage Detector – LVD

Each device has a Low Voltage Detector function, also known as LVD. This enabled the device to monitor the power supply voltage, V_{DD} , and provide a warning signal should it fall below a certain level. This function may be especially useful in battery applications where the supply voltage will gradually reduce as the battery ages, as it allows an early warning battery low signal to be generated. The Low Voltage Detector also has the capability of generating an interrupt signal.

LVD Register

The Low Voltage Detector function is controlled using a single register with the name LVDC. Three bits in this register, VLVD2~VLVD0, are used to select one of eight fixed voltages below which a low voltage condition will be determined. A low voltage condition is indicated when the LVDO bit is set. If the LVDO bit is low, this indicates that the V_{DD} voltage is above the preset low voltage value. The LVDEN bit is used to control the overall on/off function of the low voltage detector. Setting the bit high will enable the low voltage detector. Clearing the bit to zero will switch off the internal low voltage detector circuits. As the low voltage detector will consume a certain amount of power, it may be desirable to switch off the circuit when not in use, an important consideration in power sensitive battery powered applications.

• LVDC Register

Bit	7	6	5	4	3	2	1	0
Name	—	—	LVDO	LVDEN	VBGEN	VLVD2	VLVD1	VLVD0
R/W	—	—	R	R/W	R/W	R/W	R/W	R/W
POR	—	—	0	0	0	0	0	0

Bit 7~6 Unimplemented, read as “0”

Bit 5 **LVDO**: LVD Output flag
0: No Low Voltage Detected
1: Low Voltage Detected

Bit 4 **LVDEN**: Low Voltage Detector Enable control
0: Disable
1: Enable

Bit 3 **VBGEN**: Bandgap Voltage Output Enable control
0: Disable
1: Enable

Note that the Bandgap circuit is enabled when the LVD or LVR function is enabled or when the VBGEN bit is set high.

Bit 2~0 **VLVD2~VLVD0**: LVD Voltage selection
000: 1.8V
001: 2.0V
010: 2.4V
011: 2.7V
100: 3.0V
101: 3.3V
110: 3.6V
111: 4.0V

LVD Operation

The Low Voltage Detector function operates by comparing the power supply voltage, V_{DD} , with a pre-specified voltage level stored in the LVDC register. This has a range of between 1.8V and 4.0V. When the power supply voltage, V_{DD} , falls below this pre-determined value, the LVDO bit will be set high indicating a low power supply voltage condition. When the device is in the SLEEP mode, the low voltage detector will be disabled even if the LVDEN bit is high. After enabling the Low Voltage Detector, a time delay t_{LVDS} should be allowed for the circuitry to stabilise before reading the LVDO bit. Note also that as the V_{DD} voltage may rise and fall rather slowly, at the voltage nears that of V_{LVD} , there may be multiple bit LVDO transitions.

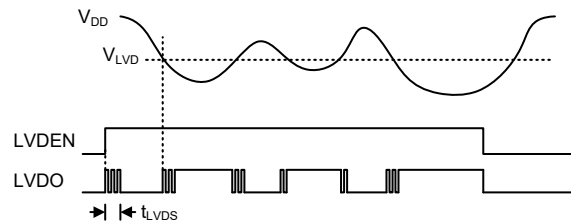

LVD Operation

The Low Voltage Detector also has its own interrupt which is contained within one of the Multi-function interrupts, providing an alternative means of low voltage detection, in addition to polling the LVDO bit. The interrupt will only be generated after a delay of t_{LVD} after the LVDO bit has been set high by a low voltage condition. In this case, the LVF interrupt request flag will be set, causing an interrupt to be generated if V_{DD} falls below the preset LVD voltage. This will cause the device to wake up from the IDLE Mode, however if the Low Voltage Detector wake-up function is not required then the LVF flag should be first set high before the device enters the IDLE Mode.

Interrupts

Interrupts are an important part of any microcontroller system. When an external event or an internal function such as a Timer Module or an A/D converter requires microcontroller attention, their corresponding interrupt will enforce a temporary suspension of the main program allowing the microcontroller to direct attention to their respective needs. The device contains several external interrupt and internal interrupt functions. The external interrupts are generated by the action of the external INT0~INT1 pins, while the internal interrupts are generated by various internal functions such as the TMs, Time Base, EEPROM, USIM, LVD and the A/D converter, etc.

Interrupt Registers

Overall interrupt control, which basically means the setting of request flags when certain microcontroller conditions occur and the setting of interrupt enable bits by the application program, is controlled by a series of registers, located in the Special Purpose Data Memory, as shown in the accompanying table. The number of registers falls into three categories. The first is the INTC0~INTC2 registers which setup the primary interrupts, the second is the MFI0~MFI2 registers which setup the Multi-function interrupts. Finally there is an INTEG register to setup the external interrupt trigger edge type.

Each register contains a number of enable bits to enable or disable individual registers as well as interrupt flags to indicate the presence of an interrupt request. The naming convention of these follows a specific pattern. First is listed an abbreviated interrupt type, then the (optional) number of that interrupt followed by either an “E” for enable/disable bit or “F” for request flag.

Function	Enable Bit	Request Flag	Notes
Global	EMI	—	—
INTn Pin	INTnE	INTnF	n=0~1
USIM	USIME	USIMF	—
Time Base	TBnE	TBnF	n=0~1
A/D Converter	ADE	ADF	—
Multi-function	MFnE	MFnF	n=0~2
EEPROM	DEE	DEF	—
LVD	LVE	LVF	—
STM	STMPE	STMPF	—
	STMAE	STMAF	—
PTM	PTMnPE	PTMnPF	n=0 for HT67L2540A
	PTMnAE	PTMnAF	n=0~1 for HT67L2550A

Interrupt Register Bit Naming Conventions

Register Name	Bit							
	7	6	5	4	3	2	1	0
INTEG	—	—	—	—	INT1S1	INT1S0	INT0S1	INT0S0
INTC0	—	USIMF	INT1F	INT0F	USIME	INT1E	INT0E	EMI
INTC1	ADF	MF1F	MF0F	MF2F	ADE	MF1E	MF0E	MF2E
INTC2	—	—	TB1F	TB0F	—	—	TB1E	TB0E
MF10	—	—	STMAF	STMPF	—	—	STMAE	STMPE
MF11 (HT67L2540A)	—	—	PTM0AF	PTM0PF	—	—	PTM0AE	PTM0PE
MF11 (HT67L2550A)	PTM1AF	PTM1PF	PTM0AF	PTM0PF	PTM1AE	PTM1PE	PTM0AE	PTM0PE
MF12	—	—	DEF	LVF	—	—	DEE	LVE

Interrupt Register List

• **INTEG Register**

Bit	7	6	5	4	3	2	1	0
Name	—	—	—	—	INT1S1	INT1S0	INT0S1	INT0S0
R/W	—	—	—	—	R/W	R/W	R/W	R/W
POR	—	—	—	—	0	0	0	0

Bit 7~4 Unimplemented, read as “0”

Bit 3~2 **INT1S1~INT1S0**: Interrupt edge control for INT1 pin
 00: Disable
 01: Rising edge
 10: Falling edge
 11: Rising and falling edges

Bit 1~0 **INT0S1~INT0S0**: Interrupt edge control for INT0 pin
 00: Disable
 01: Rising edge
 10: Falling edge
 11: Rising and falling edges

• **INTC0 Register**

Bit	7	6	5	4	3	2	1	0
Name	—	USIMF	INT1F	INT0F	USIME	INT1E	INT0E	EMI
R/W	—	R/W	R/W	R/W	R/W	R/W	R/W	R/W
POR	—	0	0	0	0	0	0	0

- Bit 7 Unimplemented, read as “0”
- Bit 6 **USIMF**: USIM interrupt request flag
0: No request
1: Interrupt request
- Bit 5 **INT1F**: INT1 interrupt request flag
0: No request
1: Interrupt request
- Bit 4 **INT0F**: INT0 interrupt request flag
0: No request
1: Interrupt request
- Bit 3 **USIME**: USIM interrupt control
0: Disable
1: Enable
- Bit 2 **INT1E**: INT1 interrupt control
0: Disable
1: Enable
- Bit 1 **INT0E**: INT0 interrupt control
0: Disable
1: Enable
- Bit 0 **EMI**: Global interrupt control
0: Disable
1: Enable

• **INTC1 Register**

Bit	7	6	5	4	3	2	1	0
Name	ADF	MF1F	MF0F	MF2F	ADE	MF1E	MF0E	MF2E
R/W	R/W	R/W	R/W	R/W	R/W	R/W	R/W	R/W
POR	0	0	0	0	0	0	0	0

- Bit 7 **ADF**: A/D converter interrupt request flag
0: No request
1: Interrupt request
- Bit 6 **MF1F**: Multi-function interrupt 1 request flag
0: No request
1: Interrupt request
- Bit 5 **MF0F**: Multi-function interrupt 0 request flag
0: No request
1: Interrupt request
- Bit 4 **MF2F**: Multi-function interrupt 2 request flag
0: No request
1: Interrupt request
- Bit 3 **ADE**: A/D converter interrupt control
0: Disable
1: Enable
- Bit 2 **MF1E**: Multi-function interrupt 1 control
0: Disable
1: Enable

- Bit 1 **MF0E**: Multi-function interrupt 0 control
0: Disable
1: Enable
- Bit 0 **MF2E**: Multi-function interrupt 2 control
0: Disable
1: Enable

• **INTC2 Register**

Bit	7	6	5	4	3	2	1	0
Name	—	—	TB1F	TB0F	—	—	TB1E	TB0E
R/W	—	—	R/W	R/W	—	—	R/W	R/W
POR	—	—	0	0	—	—	0	0

- Bit 7~6 Unimplemented, read as “0”
- Bit 5 **TB1F**: Time Base 1 interrupt request flag
0: No request
1: Interrupt request
- Bit 4 **TB0F**: Time Base 0 interrupt request flag
0: No request
1: Interrupt request
- Bit 3~2 Unimplemented, read as “0”
- Bit 1 **TB1E**: Time Base 1 interrupt control
0: Disable
1: Enable
- Bit 0 **TB0E**: Time Base 0 interrupt control
0: Disable
1: Enable

• **MFIO Register**

Bit	7	6	5	4	3	2	1	0
Name	—	—	STMAF	STMPF	—	—	STMAE	STMPE
R/W	—	—	R/W	R/W	—	—	R/W	R/W
POR	—	—	0	0	—	—	0	0

- Bit 7~6 Unimplemented, read as “0”
- Bit 5 **STMAF**: STM Comparator A match interrupt request flag
0: No request
1: Interrupt request
- Bit 4 **STMPF**: STM Comparator P match interrupt request flag
0: No request
1: Interrupt request
- Bit 3~2 Unimplemented, read as “0”
- Bit 1 **STMAE**: STM Comparator A match interrupt control
0: Disable
1: Enable
- Bit 0 **STMPE**: STM Comparator P match interrupt control
0: Disable
1: Enable

• **MF1 Register – HT67L2540A**

Bit	7	6	5	4	3	2	1	0
Name	—	—	PTM0AF	PTM0PF	—	—	PTM0AE	PTM0PE
R/W	—	—	R/W	R/W	—	—	R/W	R/W
POR	—	—	0	0	—	—	0	0

- Bit 7~6 Unimplemented, read as “0”
- Bit 5 **PTM0AF**: PTM0 Comparator A match interrupt request flag
 0: No request
 1: Interrupt request
- Bit 4 **PTM0PF**: PTM0 Comparator P match interrupt request flag
 0: No request
 1: Interrupt request
- Bit 3~2 Unimplemented, read as “0”
- Bit 1 **PTM0AE**: PTM0 Comparator A match interrupt control
 0: Disable
 1: Enable
- Bit 0 **PTM0PE**: PTM0 Comparator P match interrupt control
 0: Disable
 1: Enable

• **MF1 Register – HT67L2550A**

Bit	7	6	5	4	3	2	1	0
Name	PTM1AF	PTM1PF	PTM0AF	PTM0PF	PTM1AE	PTM1PE	PTM0AE	PTM0PE
R/W	R/W	R/W	R/W	R/W	R/W	R/W	R/W	R/W
POR	0	0	0	0	0	0	0	0

- Bit 7 **PTM1AF**: PTM1 Comparator A match interrupt request flag
 0: No request
 1: Interrupt request
- Bit 6 **PTM1PF**: PTM1 Comparator P match interrupt request flag
 0: No request
 1: Interrupt request
- Bit 5 **PTM0AF**: PTM0 Comparator A match interrupt request flag
 0: No request
 1: Interrupt request
- Bit 4 **PTM0PF**: PTM0 Comparator P match interrupt request flag
 0: No request
 1: Interrupt request
- Bit 3 **PTM1AE**: PTM1 Comparator A match interrupt control
 0: Disable
 1: Enable
- Bit 2 **PTM1PE**: PTM1 Comparator P match interrupt control
 0: Disable
 1: Enable
- Bit 1 **PTM0AE**: PTM0 Comparator A match interrupt control
 0: Disable
 1: Enable
- Bit 0 **PTM0PE**: PTM0 Comparator P match interrupt control
 0: Disable
 1: Enable

• **MFI2 Register**

Bit	7	6	5	4	3	2	1	0
Name	—	—	DEF	LVF	—	—	DEE	LVE
R/W	—	—	R/W	R/W	—	—	R/W	R/W
POR	—	—	0	0	—	—	0	0

- Bit 7~6 Unimplemented, read as “0”
- Bit 5 **DEF**: Data EEPROM interrupt request flag
 0: No request
 1: Interrupt request
- Bit 4 **LVF**: LVD interrupt request flag
 0: No request
 1: Interrupt request
- Bit 3~2 Unimplemented, read as “0”
- Bit 1 **DEE**: Data EEPROM interrupt control
 0: Disable
 1: Enable
- Bit 0 **LVE**: LVD interrupt control
 0: Disable
 1: Enable

Interrupt Operation

When the conditions for an interrupt event occur, such as a TM Comparator P or Comparator A match or A/D conversion completion etc., the relevant interrupt request flag will be set. Whether the request flag actually generates a program jump to the relevant interrupt vector is determined by the condition of the interrupt enable bit. If the enable bit is set high then the program will jump to its relevant vector; if the enable bit is zero then although the interrupt request flag is set an actual interrupt will not be generated and the program will not jump to the relevant interrupt vector. The global interrupt enable bit, if cleared to zero, will disable all interrupts.

When an interrupt is generated, the Program Counter, which stores the address of the next instruction to be executed, will be transferred onto the stack. The Program Counter will then be loaded with a new address which will be the value of the corresponding interrupt vector. The microcontroller will then fetch its next instruction from this interrupt vector. The instruction at this vector will usually be a “JMP” which will jump to another section of program which is known as the interrupt service routine. Here is located the code to control the appropriate interrupt. The interrupt service routine must be terminated with a “RETI”, which retrieves the original Program Counter address from the stack and allows the microcontroller to continue with normal execution at the point where the interrupt occurred.

The various interrupt enable bits, together with their associated request flags, are shown in the accompanying diagrams with their order of priority. Some interrupt sources have their own individual vector while others share the same multi-function interrupt vector. Once an interrupt subroutine is serviced, all the other interrupts will be blocked, as the global interrupt enable bit, EMI bit will be cleared automatically. This will prevent any further interrupt nesting from occurring. However, if other interrupt requests occur during this interval, although the interrupt will not be immediately serviced, the request flag will still be recorded.

If an interrupt requires immediate servicing while the program is already in another interrupt service routine, the EMI bit should be set after entering the routine, to allow interrupt nesting. If the stack is full, the interrupt request will not be acknowledged, even if the related interrupt is enabled, until the Stack Pointer is decremented. If immediate service is desired, the stack must be prevented from

becoming full. In case of simultaneous requests, the accompanying diagram shows the priority that is applied. All of the interrupt request flags when set will wake up the device if it is in SLEEP or IDLE Mode, however to prevent a wake-up from occurring the corresponding flag should be set before the device is in SLEEP or IDLE Mode.

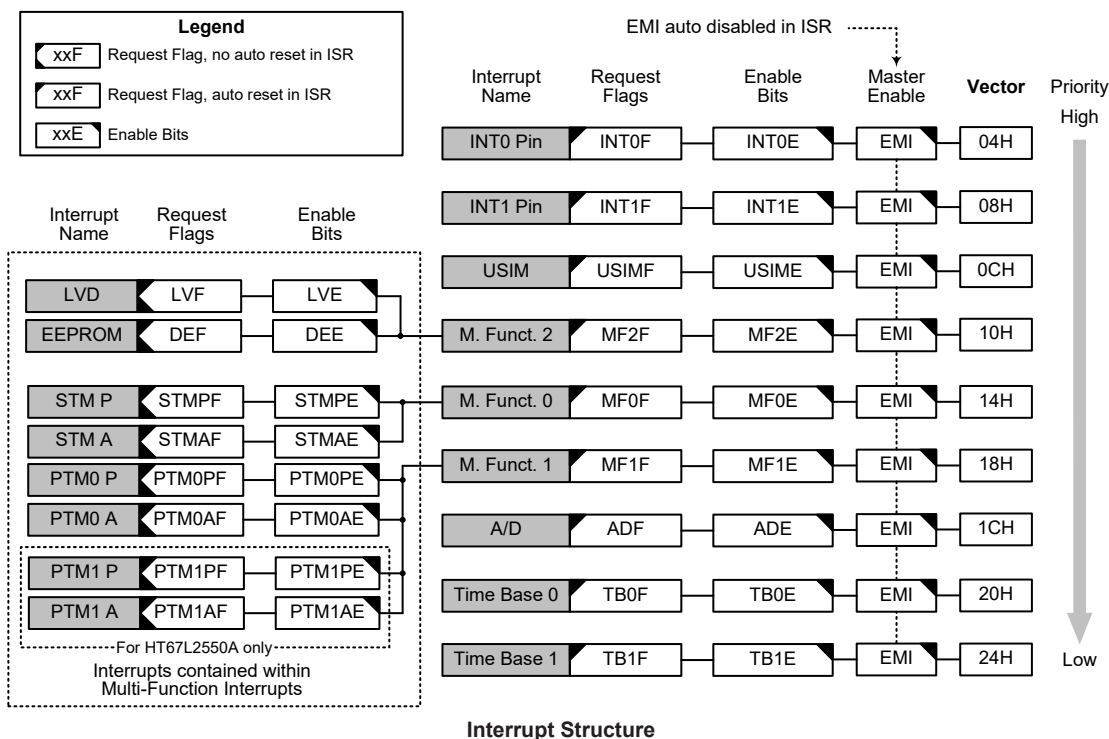

External Interrupts

The external interrupts are controlled by signal transitions on the pins INT0 and INT1. An external interrupt request will take place when the external interrupt request flags, INT0F~INT1F, are set, which will occur when a transition, whose type is chosen by the edge select bits, appears on the external interrupt pins. To allow the program to branch to their respective interrupt vector addresses, the global interrupt enable bit, EMI, and respective external interrupt enable bit, INT0E~INT1E, must first be set. Additionally the correct interrupt edge type must be selected using the INTEG register to enable the external interrupt function and to choose the trigger edge type. As the external interrupt pins are pin-shared with I/O pins, they can only be configured as external interrupt pins if their external interrupt enable bit in the corresponding interrupt register has been set and the external interrupt pin is selected by the corresponding pin-shared function selection bits. The pin must also be setup as an input by setting the corresponding bit in the port control register.

When the interrupt is enabled, the stack is not full and the correct transition type appears on the external interrupt pin, a subroutine call to the external interrupt vector, will take place. When the interrupt is serviced, the external interrupt request flags, INT0F~INT1F, will be automatically reset and the EMI bit will be automatically cleared to disable other interrupts. Note that any pull-high resistor selections on the external interrupt pins will remain valid even if the pin is used as an external interrupt input.

The INTEG register is used to select the type of active edge that will trigger the external interrupt. A choice of either rising or falling or both edge types can be chosen to trigger an external interrupt. Note that the INTEG register can also be used to disable the external interrupt function.

A/D Converter Interrupt

An A/D Converter Interrupt request will take place when the A/D Converter Interrupt request flag, ADF, is set, which occurs when the A/D conversion process finishes. To allow the program to branch to its interrupt vector address, the global interrupt enable bit, EMI, and A/D Interrupt enable bit, ADE, must first be set. When the interrupt is enabled, the stack is not full and the A/D conversion process has ended, a subroutine call to the A/D Converter Interrupt vector, will take place. When the Interrupt is serviced, the A/D Interrupt flag, ADF, will be automatically cleared. The EMI bit will also be automatically cleared to disable other interrupts.

Universal Serial Interface Module Interrupt

The Universal Serial Interface Module Interrupt, also known as the USIM interrupt, will take place when the USIM Interrupt request flag, USIMF, is set. As the USIM interface can operate in three modes which are SPI mode, I²C mode and UART mode, the USIMF flag can be set by different conditions depending on the selected interface mode.

If the SPI or I²C mode is selected, the USIM interrupt can be triggered when a byte of data has been received or transmitted by the SPI/I²C interface, or an I²C slave address match occurs, or an I²C bus time-out occurs. If the UART mode is selected, several individual UART conditions including a transmitter data register empty, transmitter idle, receiver data available, receiver overrun, address detect and an URX/UTX pin wake-up, can generate a USIM interrupt with the USIMF flag bit set high.

To allow the program to branch to its interrupt vector address, the global interrupt enable bit, EMI, and the Serial Interface Interrupt enable bit, USIME, must first be set. When the interrupt is enabled, the stack is not full and any of the above described situations occurs, a subroutine call to the USIM Interrupt vector, will take place. When the interrupt is serviced, the Universal Serial Interface Interrupt flag, USIMF, will be automatically cleared. The EMI bit will also be automatically cleared to disable other interrupts.

Note that if the USIM interrupt is triggered by the UART interface, after the interrupt has been serviced, the UUSR register flags will only be cleared when certain actions are taken by the UART, the details of which are given in the UART section.

Time Base Interrupts

The function of the Time Base Interrupts is to provide regular time signals in the form of an internal interrupt. They are controlled by the overflow signals from their respective timer functions. When these happen their respective interrupt request flags, TB0F or TB1F, will be set. To allow the program to branch to their respective interrupt vector addresses, the global interrupt enable bit, EMI and Time Base enable bit, TB0E or TB1E, must first be set. When the interrupt is enabled, the stack is not full and the Time Base overflows, a subroutine call to their respective vector locations will take place. When the interrupt is serviced, the respective interrupt request flag, TB0F or TB1F, will be automatically reset and the EMI bit will be cleared to disable other interrupts.

The purpose of the Time Base Interrupt is to provide an interrupt signal at fixed time periods. Their clock sources, f_{PSC0} or f_{PSC1} , originate from the internal clock source f_{SYS} , $f_{SYS}/4$, f_{SUB} or f_{4kHz} and then passes through a divider, the division ratio of which is selected by programming the appropriate bits in the TB0C and TB1C registers to obtain longer interrupt periods whose value ranges. The clock source that generate f_{PSC0} or f_{PSC1} , which in turn controls the Time Base interrupt period, is selected using the CLKSEL0[1:0] and CLKSEL1[1:0] bits in the PSC0R or PSC1R register respectively.

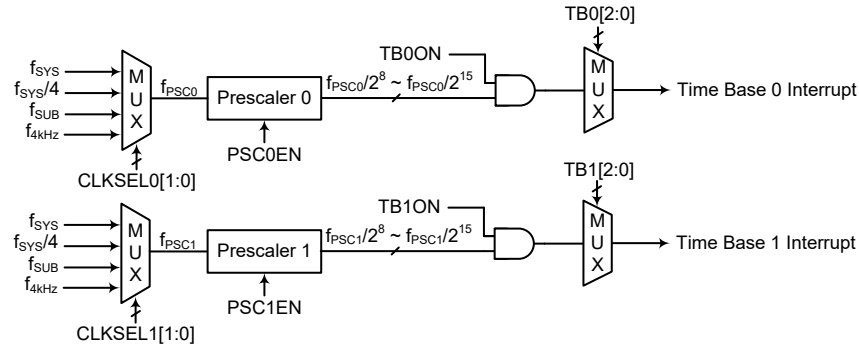

Time Base Interrupts

• PSC0R Register

Bit	7	6	5	4	3	2	1	0
Name	—	—	—	—	—	PSC0EN	CLKSEL01	CLKSEL00
R/W	—	—	—	—	—	R/W	R/W	R/W
POR	—	—	—	—	—	0	0	0

Bit 7~3 Unimplemented, read as “0”

Bit 2 **PSC0EN**: Prescaler 0 clock enable control
0: Disable
1: Enable

This PSC0EN bit is the Prescaler 0 clock enable or disable control bit. When the Prescale 0 clock is disabled, it can reduce extra power consumption.

Bit 1~0 **CLKSEL01~CLKSEL00**: Prescaler 0 clock source selection
00: f_{SYS}
01: $f_{SYS}/4$
10: f_{SUB}
11: f_{4kHz}

• PSC1R Register

Bit	7	6	5	4	3	2	1	0
Name	—	—	—	—	—	PSC1EN	CLKSEL11	CLKSEL10
R/W	—	—	—	—	—	R/W	R/W	R/W
POR	—	—	—	—	—	0	0	0

Bit 7~3 Unimplemented, read as “0”

Bit 2 **PSC1EN**: Prescaler 1 clock enable control
0: Disable
1: Enable

This PSC1EN bit is the Prescaler 1 clock enable or disable control bit. When the Prescale 1 clock is disabled, it can reduce extra power consumption.

Bit 1~0 **CLKSEL11~CLKSEL10**: Prescaler 1 clock source selection
00: f_{SYS}
01: $f_{SYS}/4$
10: f_{SUB}
11: f_{4kHz}

• **TB0C Register**

Bit	7	6	5	4	3	2	1	0
Name	TB0ON	—	—	—	—	TB02	TB01	TB00
R/W	R/W	—	—	—	—	R/W	R/W	R/W
POR	0	—	—	—	—	0	0	0

Bit 7 **TB0ON**: Time Base 0 Control
0: Disable
1: Enable

Bit 6~3 Unimplemented, read as “0”

Bit 2~0 **TB02~TB00**: Select Time Base 0 Time-out Period
000: $2^8/f_{PSC0}$
001: $2^9/f_{PSC0}$
010: $2^{10}/f_{PSC0}$
011: $2^{11}/f_{PSC0}$
100: $2^{12}/f_{PSC0}$
101: $2^{13}/f_{PSC0}$
110: $2^{14}/f_{PSC0}$
111: $2^{15}/f_{PSC0}$

• **TB1C Register**

Bit	7	6	5	4	3	2	1	0
Name	TB1ON	—	—	—	—	TB12	TB11	TB10
R/W	R/W	—	—	—	—	R/W	R/W	R/W
POR	0	—	—	—	—	0	0	0

Bit 7 **TB1ON**: Time Base 1 Control
0: Disable
1: Enable

Bit 6~3 Unimplemented, read as “0”

Bit 2~0 **TB12~TB10**: Select Time Base 1 Time-out Period
000: $2^8/f_{PSC1}$
001: $2^9/f_{PSC1}$
010: $2^{10}/f_{PSC1}$
011: $2^{11}/f_{PSC1}$
100: $2^{12}/f_{PSC1}$
101: $2^{13}/f_{PSC1}$
110: $2^{14}/f_{PSC1}$
111: $2^{15}/f_{PSC}$

Multi-function Interrupts

Within the devices there are three Multi-function interrupts. Unlike the other independent interrupts, these interrupts have no independent source, but rather are formed from other existing interrupt sources, namely the TM Interrupts, EEPROM Interrupt and LVD Interrupt.

A Multi-function interrupt request will take place when any of the Multi-function interrupt request flags, MFnF are set. The Multi-function interrupt flags will be set when any of their included functions generate an interrupt request flag. To allow the program to branch to their respective interrupt vector addresses, when the Multi-function interrupt is enabled and the stack is not full, and either one of the interrupts contained within each of Multi-function interrupt occurs, a subroutine call to one of the Multi-function interrupt vectors will take place. When the interrupt is serviced, the related Multi-Function request flag will be automatically reset and the EMI bit will be automatically cleared to disable other interrupts.

However, it must be noted that, although the Multi-function Interrupt flags will be automatically reset when the interrupt is serviced, the request flags from the original source of the Multi-function interrupts will not be automatically reset and must be manually reset by the application program.

EEPROM Interrupt

The EEPROM interrupt is contained within the Multi-function Interrupt. An EEPROM Interrupt request will take place when the EEPROM Interrupt request flag, DEF, is set, which occurs when an EEPROM Write cycle ends. To allow the program to branch to its interrupt vector address, the global interrupt enable bit, EMI, EEPROM Interrupt enable bit, DEE, and associated Multi-function interrupt enable bit, must first be set. When the interrupt is enabled, the stack is not full and an EEPROM Write cycle ends, a subroutine call to the Multi-function Interrupt vector, will take place. When the EEPROM Interrupt is serviced, the EMI bit will be automatically cleared to disable other interrupts, however only the Multi-function interrupt request flag will be also automatically cleared. As the DEF flag will not be automatically cleared, it has to be cleared by the application program.

LVD Interrupt

The Low Voltage Detector Interrupt is contained within the Multi-function Interrupt. An LVD Interrupt request will take place when the LVD Interrupt request flag, LVF, is set, which occurs when the Low Voltage Detector function detects a low power supply voltage. To allow the program to branch to its interrupt vector address, the global interrupt enable bit, EMI, Low Voltage Interrupt enable bit, LVE, and associated Multi-function interrupt enable bit, must first be set. When the interrupt is enabled, the stack is not full and a low voltage condition occurs, a subroutine call to the Multi-function Interrupt vector, will take place. When the Low Voltage Interrupt is serviced, the EMI bit will be automatically cleared to disable other interrupts, however only the Multi-function interrupt request flag will be also automatically cleared. As the LVF flag will not be automatically cleared, it has to be cleared by the application program.

TM Interrupts

The Standard and Periodic Type TMs each has two interrupts, one comes from the comparator A match situation and the other comes from the comparator P match situation. All of the TM interrupts are contained within the Multi-function Interrupts. For all of the TM types there are two interrupt request flags and two enable control bits. A TM interrupt request will take place when any of the TM request flags are set, a situation which occurs when a TM comparator P or A match situation happens.

To allow the program to branch to their respective interrupt vector addresses, the global interrupt enable bit, EMI, respective TM Interrupt enable bit, and relevant Multi-function Interrupt enable bit, MFnE, must first be set. When the interrupt is enabled, the stack is not full and a TM comparator match situation occurs, a subroutine call to the Multi-function Interrupt vector location, will take place. When the TM interrupt is serviced, the EMI bit will be automatically cleared to disable other interrupts, however only the related MFnF flag will be automatically cleared. As the TM interrupt request flags will not be automatically cleared, they have to be cleared by the application program.

Interrupt Wake-up Function

Each of the interrupt functions has the capability of waking up the microcontroller when in the SLEEP or IDLE Mode. A wake-up is generated when an interrupt request flag changes from low to high and is independent of whether the interrupt is enabled or not. Therefore, even though the device is in the SLEEP or IDLE Mode and its system oscillator stopped, situations such as external edge transitions on the external interrupt pins or a low power supply voltage may cause their respective interrupt flag to be set high and consequently generate an interrupt. Care must therefore be taken if spurious wake-up situations are to be avoided. If an interrupt wake-up function is to be disabled then the corresponding interrupt request flag should be set high before the device enters the SLEEP or IDLE Mode. The interrupt enable bits have no effect on the interrupt wake-up function.

Programming Considerations

By disabling the relevant interrupt enable bits, a requested interrupt can be prevented from being serviced, however, once an interrupt request flag is set, it will remain in this condition in the interrupt register until the corresponding interrupt is serviced or until the request flag is cleared by the application program.

Where a certain interrupt is contained within a Multi-function interrupt, then when the interrupt service routine is executed, as only the Multi-function interrupt request flag, MFnF, will be automatically cleared, the individual request flag for the function needs to be cleared by the application program.

It is recommended that programs do not use the “CALL” instruction within the interrupt service subroutine. Interrupts often occur in an unpredictable manner or need to be serviced immediately. If only one stack is left and the interrupt is not well controlled, the original control sequence will be damaged once a CALL subroutine is executed in the interrupt subroutine.

Every interrupt has the capability of waking up the microcontroller when it is in the SLEEP or IDLE Mode, the wake-up being generated when the interrupt request flag changes from low to high. If it is required to prevent a certain interrupt from waking up the microcontroller then its respective request flag should be first set high before enter SLEEP or IDLE Mode.

As only the Program Counter is pushed onto the stack, then when the interrupt is serviced, if the contents of the accumulator, status register or other registers are altered by the interrupt service program, their contents should be saved to the memory at the beginning of the interrupt service routine.

To return from an interrupt subroutine, either a RET or RETI instruction may be executed. The RETI instruction in addition to executing a return to the main program also automatically sets the EMI bit high to allow further interrupts. The RET instruction however only executes a return to the main program leaving the EMI bit in its present zero state and therefore disabling the execution of further interrupts.

Configuration Options

Configuration options refer to certain options within the MCU that are programmed into the device during the programming process. During the development process, these options are selected using the HT-IDE software development tools. All options must be defined for proper system function, the details of which are shown in the table.

No.	Options
Oscillator Options	
1	HIRC Frequency Selection – f_{HIRC} : 2MHz, 4MHz or 8MHz
2	MIRC Frequency Selection – f_{MIRC} : 64kHz, 128kHz, 256kHz or 512kHz
Temperature Sensor Options	
3	Temperature Calibration Selection: 1: Disable 2: Enable

Note: 1. When the HIRC/MIRC has been configured at a frequency shown in this table, the IRC2~IRC0 bits should also be setup to select the same frequency to achieve the HIRC/MIRC frequency accuracy specified in the A.C. Characteristics.

2. If it is required to implement temperature calibration and “Enable” has been selected, when using the writer for programming, it will detect whether the temperature module (EMDE001A) is connected or not. If the temperature module is not connected, the writer will indicate an error and cannot implement programming.

Application Circuits

HT67L2540A

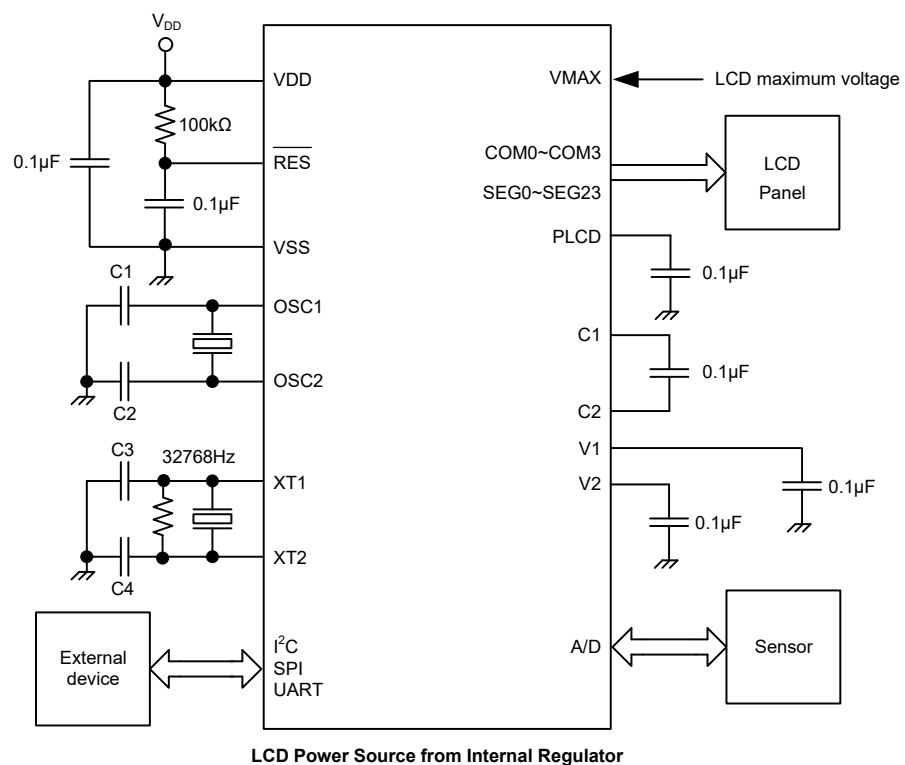
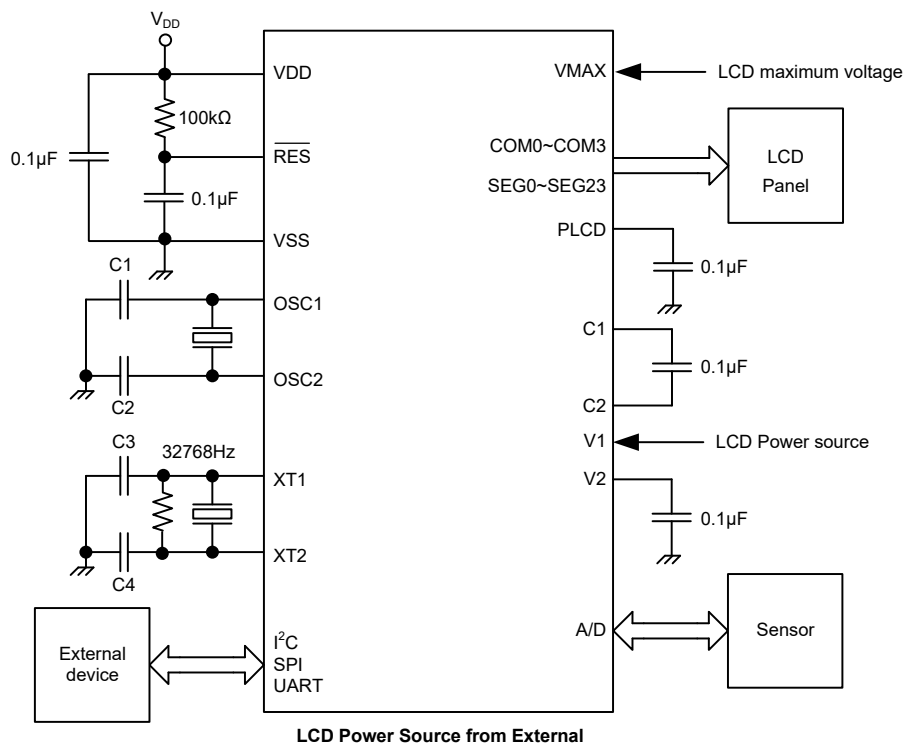

HT67L2550A

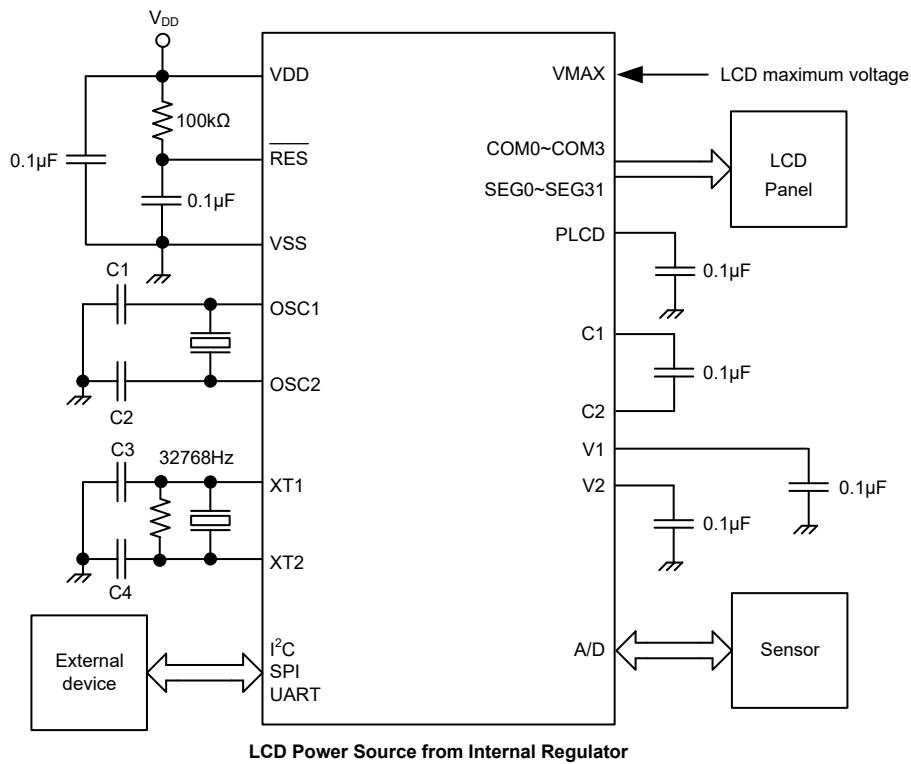
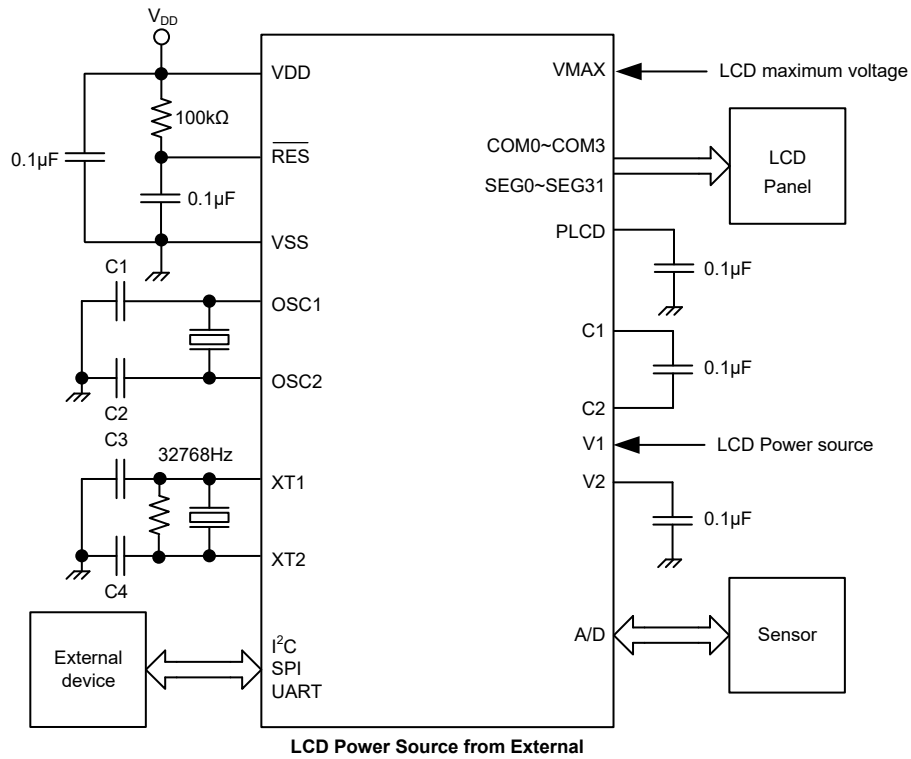

Instruction Set

Introduction

Central to the successful operation of any microcontroller is its instruction set, which is a set of program instruction codes that directs the microcontroller to perform certain operations. In the case of Holtek microcontroller, a comprehensive and flexible set of over 60 instructions is provided to enable programmers to implement their application with the minimum of programming overheads.

For easier understanding of the various instruction codes, they have been subdivided into several functional groupings.

Instruction Timing

Most instructions are implemented within one instruction cycle. The exceptions to this are branch, call, or table read instructions where two instruction cycles are required. One instruction cycle is equal to 4 system clock cycles, therefore in the case of an 8MHz system oscillator, most instructions would be implemented within 0.5 μ s and branch or call instructions would be implemented within 1 μ s. Although instructions which require one more cycle to implement are generally limited to the JMP, CALL, RET, RETI and table read instructions, it is important to realize that any other instructions which involve manipulation of the Program Counter Low register or PCL will also take one more cycle to implement. As instructions which change the contents of the PCL will imply a direct jump to that new address, one more cycle will be required. Examples of such instructions would be “CLR PCL” or “MOV PCL, A”. For the case of skip instructions, it must be noted that if the result of the comparison involves a skip operation then this will also take one more cycle, if no skip is involved then only one cycle is required.

Moving and Transferring Data

The transfer of data within the microcontroller program is one of the most frequently used operations. Making use of several kinds of MOV instructions, data can be transferred from registers to the Accumulator and vice-versa as well as being able to move specific immediate data directly into the Accumulator. One of the most important data transfer applications is to receive data from the input ports and transfer data to the output ports.

Arithmetic Operations

The ability to perform certain arithmetic operations and data manipulation is a necessary feature of most microcontroller applications. Within the Holtek microcontroller instruction set are a range of add and subtract instruction mnemonics to enable the necessary arithmetic to be carried out. Care must be taken to ensure correct handling of carry and borrow data when results exceed 255 for addition and less than 0 for subtraction. The increment and decrement instructions such as INC, INCA, DEC and DECA provide a simple means of increasing or decreasing by a value of one of the values in the destination specified.

Logical and Rotate Operation

The standard logical operations such as AND, OR, XOR and CPL all have their own instruction within the Holtek microcontroller instruction set. As with the case of most instructions involving data manipulation, data must pass through the Accumulator which may involve additional programming steps. In all logical data operations, the zero flag may be set if the result of the operation is zero. Another form of logical data manipulation comes from the rotate instructions such as RR, RL, RRC and RLC which provide a simple means of rotating one bit right or left. Different rotate instructions exist depending on program requirements. Rotate instructions are useful for serial port programming applications where data can be rotated from an internal register into the Carry bit from where it can be examined and the necessary serial bit set high or low. Another application which rotate data operations are used is to implement multiplication and division calculations.

Branches and Control Transfer

Program branching takes the form of either jumps to specified locations using the JMP instruction or to a subroutine using the CALL instruction. They differ in the sense that in the case of a subroutine call, the program must return to the instruction immediately when the subroutine has been carried out. This is done by placing a return instruction “RET” in the subroutine which will cause the program to jump back to the address right after the CALL instruction. In the case of a JMP instruction, the program simply jumps to the desired location. There is no requirement to jump back to the original jumping off point as in the case of the CALL instruction. One special and extremely useful set of branch instructions are the conditional branches. Here a decision is first made regarding the condition of a certain data memory or individual bits. Depending upon the conditions, the program will continue with the next instruction or skip over it and jump to the following instruction. These instructions are the key to decision making and branching within the program perhaps determined by the condition of certain input switches or by the condition of internal data bits.

Bit Operations

The ability to provide single bit operations on Data Memory is an extremely flexible feature of all Holtek microcontrollers. This feature is especially useful for output port bit programming where individual bits or port pins can be directly set high or low using either the “SET [m].i” or “CLR [m].i” instructions respectively. The feature removes the need for programmers to first read the 8-bit output port, manipulate the input data to ensure that other bits are not changed and then output the port with the correct new data. This read-modify-write process is taken care of automatically when these bit operation instructions are used.

Table Read Operations

Data storage is normally implemented by using registers. However, when working with large amounts of fixed data, the volume involved often makes it inconvenient to store the fixed data in the Data Memory. To overcome this problem, Holtek microcontrollers allow an area of Program Memory to be setup as a table where data can be directly stored. A set of easy to use instructions provides the means by which this fixed data can be referenced and retrieved from the Program Memory.

Other Operations

In addition to the above functional instructions, a range of other instructions also exist such as the “HALT” instruction for Power-down operations and instructions to control the operation of the Watchdog Timer for reliable program operations under extreme electric or electromagnetic environments. For their relevant operations, refer to the functional related sections.

Instruction Set Summary

The instructions related to the data memory access in the following table can be used when the desired data memory is located in Data Memory sector 0.

Table Conventions

x: Bits immediate data
m: Data Memory address
A: Accumulator
i: 0~7 number of bits
addr: Program memory address

Mnemonic	Description	Cycles	Flag Affected
Arithmetic			
ADD A,[m]	Add Data Memory to ACC	1	Z, C, AC, OV, SC
ADDM A,[m]	Add ACC to Data Memory	1 ^{Note}	Z, C, AC, OV, SC
ADD A,x	Add immediate data to ACC	1	Z, C, AC, OV, SC
ADC A,[m]	Add Data Memory to ACC with Carry	1	Z, C, AC, OV, SC
ADCM A,[m]	Add ACC to Data memory with Carry	1 ^{Note}	Z, C, AC, OV, SC
SUB A,x	Subtract immediate data from the ACC	1	Z, C, AC, OV, SC, CZ
SUB A,[m]	Subtract Data Memory from ACC	1	Z, C, AC, OV, SC, CZ
SUBM A,[m]	Subtract Data Memory from ACC with result in Data Memory	1 ^{Note}	Z, C, AC, OV, SC, CZ
SBC A,x	Subtract immediate data from ACC with Carry	1	Z, C, AC, OV, SC, CZ
SBC A,[m]	Subtract Data Memory from ACC with Carry	1	Z, C, AC, OV, SC, CZ
SBCM A,[m]	Subtract Data Memory from ACC with Carry, result in Data Memory	1 ^{Note}	Z, C, AC, OV, SC, CZ
DAA [m]	Decimal adjust ACC for Addition with result in Data Memory	1 ^{Note}	C
Logic Operation			
AND A,[m]	Logical AND Data Memory to ACC	1	Z
OR A,[m]	Logical OR Data Memory to ACC	1	Z
XOR A,[m]	Logical XOR Data Memory to ACC	1	Z
ANDM A,[m]	Logical AND ACC to Data Memory	1 ^{Note}	Z
ORM A,[m]	Logical OR ACC to Data Memory	1 ^{Note}	Z
XORM A,[m]	Logical XOR ACC to Data Memory	1 ^{Note}	Z
AND A,x	Logical AND immediate Data to ACC	1	Z
OR A,x	Logical OR immediate Data to ACC	1	Z
XOR A,x	Logical XOR immediate Data to ACC	1	Z
CPL [m]	Complement Data Memory	1 ^{Note}	Z
CPLA [m]	Complement Data Memory with result in ACC	1	Z
Increment & Decrement			
INCA [m]	Increment Data Memory with result in ACC	1	Z
INC [m]	Increment Data Memory	1 ^{Note}	Z
DECA [m]	Decrement Data Memory with result in ACC	1	Z
DEC [m]	Decrement Data Memory	1 ^{Note}	Z
Rotate			
RRA [m]	Rotate Data Memory right with result in ACC	1	None
RR [m]	Rotate Data Memory right	1 ^{Note}	None
RRCA [m]	Rotate Data Memory right through Carry with result in ACC	1	C
RRC [m]	Rotate Data Memory right through Carry	1 ^{Note}	C
RLA [m]	Rotate Data Memory left with result in ACC	1	None
RL [m]	Rotate Data Memory left	1 ^{Note}	None
RLCA [m]	Rotate Data Memory left through Carry with result in ACC	1	C
RLC [m]	Rotate Data Memory left through Carry	1 ^{Note}	C

Mnemonic	Description	Cycles	Flag Affected
Data Move			
MOV A,[m]	Move Data Memory to ACC	1	None
MOV [m],A	Move ACC to Data Memory	1 ^{Note}	None
MOV A,x	Move immediate data to ACC	1	None
Bit Operation			
CLR [m].i	Clear bit of Data Memory	1 ^{Note}	None
SET [m].i	Set bit of Data Memory	1 ^{Note}	None
Branch Operation			
JMP addr	Jump unconditionally	2	None
SZ [m]	Skip if Data Memory is zero	1 ^{Note}	None
SZA [m]	Skip if Data Memory is zero with data movement to ACC	1 ^{Note}	None
SZ [m].i	Skip if bit i of Data Memory is zero	1 ^{Note}	None
SNZ [m]	Skip if Data Memory is not zero	1 ^{Note}	None
SNZ [m].i	Skip if bit i of Data Memory is not zero	1 ^{Note}	None
SIZ [m]	Skip if increment Data Memory is zero	1 ^{Note}	None
SDZ [m]	Skip if decrement Data Memory is zero	1 ^{Note}	None
SIZA [m]	Skip if increment Data Memory is zero with result in ACC	1 ^{Note}	None
SDZA [m]	Skip if decrement Data Memory is zero with result in ACC	1 ^{Note}	None
CALL addr	Subroutine call	2	None
RET	Return from subroutine	2	None
RET A,x	Return from subroutine and load immediate data to ACC	2	None
RETI	Return from interrupt	2	None
Table Read Operation			
TABRD [m]	Read table (specific page) to TBLH and Data Memory	2 ^{Note}	None
TABRDL [m]	Read table (last page) to TBLH and Data Memory	2 ^{Note}	None
ITABRD [m]	Increment table pointer TBLP first and Read table (specific page) to TBLH and Data Memory	2 ^{Note}	None
ITABRDL [m]	Increment table pointer TBLP first and Read table (last page) to TBLH and Data Memory	2 ^{Note}	None
Miscellaneous			
NOP	No operation	1	None
CLR [m]	Clear Data Memory	1 ^{Note}	None
SET [m]	Set Data Memory	1 ^{Note}	None
CLR WDT	Clear Watchdog Timer	1	TO, PDF
SWAP [m]	Swap nibbles of Data Memory	1 ^{Note}	None
SWAPA [m]	Swap nibbles of Data Memory with result in ACC	1	None
HALT	Enter power down mode	1	TO, PDF

Note: 1. For skip instructions, if the result of the comparison involves a skip then two cycles are required, if no skip takes place only one cycle is required.

2. Any instruction which changes the contents of the PCL will also require 2 cycles for execution.

Extended Instruction Set

The extended instructions are used to support the full range address access for the data memory. When the accessed data memory is located in any data memory sector except sector 0, the extended instruction can be used to directly access the data memory instead of using the indirect addressing access. This can not only reduce the use of Flash memory space but also improve the CPU execution efficiency.

Mnemonic	Description	Cycles	Flag Affected
Arithmetic			
LADD A,[m]	Add Data Memory to ACC	2	Z, C, AC, OV, SC
LADDM A,[m]	Add ACC to Data Memory	2 ^{Note}	Z, C, AC, OV, SC
LADC A,[m]	Add Data Memory to ACC with Carry	2	Z, C, AC, OV, SC
LADCM A,[m]	Add ACC to Data memory with Carry	2 ^{Note}	Z, C, AC, OV, SC
LSUB A,[m]	Subtract Data Memory from ACC	2	Z, C, AC, OV, SC, CZ
LSUBM A,[m]	Subtract Data Memory from ACC with result in Data Memory	2 ^{Note}	Z, C, AC, OV, SC, CZ
LSBC A,[m]	Subtract Data Memory from ACC with Carry	2	Z, C, AC, OV, SC, CZ
LSBCM A,[m]	Subtract Data Memory from ACC with Carry, result in Data Memory	2 ^{Note}	Z, C, AC, OV, SC, CZ
LDAA [m]	Decimal adjust ACC for Addition with result in Data Memory	2 ^{Note}	C
Logic Operation			
LAND A,[m]	Logical AND Data Memory to ACC	2	Z
LOR A,[m]	Logical OR Data Memory to ACC	2	Z
LXOR A,[m]	Logical XOR Data Memory to ACC	2	Z
LANDM A,[m]	Logical AND ACC to Data Memory	2 ^{Note}	Z
LORM A,[m]	Logical OR ACC to Data Memory	2 ^{Note}	Z
LXORM A,[m]	Logical XOR ACC to Data Memory	2 ^{Note}	Z
LCPL [m]	Complement Data Memory	2 ^{Note}	Z
LCPLA [m]	Complement Data Memory with result in ACC	2	Z
Increment & Decrement			
LINCA [m]	Increment Data Memory with result in ACC	2	Z
LINC [m]	Increment Data Memory	2 ^{Note}	Z
LDECA [m]	Decrement Data Memory with result in ACC	2	Z
LDEC [m]	Decrement Data Memory	2 ^{Note}	Z
Rotate			
LRR A,[m]	Rotate Data Memory right with result in ACC	2	None
LRR [m]	Rotate Data Memory right	2 ^{Note}	None
LRRCA [m]	Rotate Data Memory right through Carry with result in ACC	2	C
LRRC [m]	Rotate Data Memory right through Carry	2 ^{Note}	C
LRLA [m]	Rotate Data Memory left with result in ACC	2	None
LRL [m]	Rotate Data Memory left	2 ^{Note}	None
LRLCA [m]	Rotate Data Memory left through Carry with result in ACC	2	C
LRLC [m]	Rotate Data Memory left through Carry	2 ^{Note}	C
Data Move			
LMOV A,[m]	Move Data Memory to ACC	2	None
LMOV [m],A	Move ACC to Data Memory	2 ^{Note}	None
Bit Operation			
LCLR [m].i	Clear bit of Data Memory	2 ^{Note}	None
LSET [m].i	Set bit of Data Memory	2 ^{Note}	None

Mnemonic	Description	Cycles	Flag Affected
Branch			
LSZ [m]	Skip if Data Memory is zero	2 ^{Note}	None
LSZA [m]	Skip if Data Memory is zero with data movement to ACC	2 ^{Note}	None
LSNZ [m]	Skip if Data Memory is not zero	2 ^{Note}	None
LSZ [m].i	Skip if bit i of Data Memory is zero	2 ^{Note}	None
LSNZ [m].i	Skip if bit i of Data Memory is not zero	2 ^{Note}	None
LSIZ [m]	Skip if increment Data Memory is zero	2 ^{Note}	None
LSDZ [m]	Skip if decrement Data Memory is zero	2 ^{Note}	None
LSIZA [m]	Skip if increment Data Memory is zero with result in ACC	2 ^{Note}	None
LSDZA [m]	Skip if decrement Data Memory is zero with result in ACC	2 ^{Note}	None
Table Read			
LTABRD [m]	Read table (specific page) to TBLH and Data Memory	3 ^{Note}	None
LTABRDL [m]	Read table (last page) to TBLH and Data Memory	3 ^{Note}	None
LITABRD [m]	Increment table pointer TBLP first and Read table (specific page) to TBLH and Data Memory	3 ^{Note}	None
LITABRDL [m]	Increment table pointer TBLP first and Read table (last page) to TBLH and Data Memory	3 ^{Note}	None
Miscellaneous			
LCLR [m]	Clear Data Memory	2 ^{Note}	None
LSET [m]	Set Data Memory	2 ^{Note}	None
LSWAP [m]	Swap nibbles of Data Memory	2 ^{Note}	None
LSWAPA [m]	Swap nibbles of Data Memory with result in ACC	2	None

- Note: 1. For these extended skip instructions, if the result of the comparison involves a skip then three cycles are required, if no skip takes place two cycles is required.
2. Any extended instruction which changes the contents of the PCL register will also require three cycles for execution.

Instruction Definition

ADC A,[m]	Add Data Memory to ACC with Carry
Description	The contents of the specified Data Memory, Accumulator and the carry flag are added. The result is stored in the Accumulator.
Operation	$ACC \leftarrow ACC + [m] + C$
Affected flag(s)	OV, Z, AC, C, SC
ADCM A,[m]	Add ACC to Data Memory with Carry
Description	The contents of the specified Data Memory, Accumulator and the carry flag are added. The result is stored in the specified Data Memory.
Operation	$[m] \leftarrow ACC + [m] + C$
Affected flag(s)	OV, Z, AC, C, SC
ADD A,[m]	Add Data Memory to ACC
Description	The contents of the specified Data Memory and the Accumulator are added. The result is stored in the Accumulator.
Operation	$ACC \leftarrow ACC + [m]$
Affected flag(s)	OV, Z, AC, C, SC
ADD A,x	Add immediate data to ACC
Description	The contents of the Accumulator and the specified immediate data are added. The result is stored in the Accumulator.
Operation	$ACC \leftarrow ACC + x$
Affected flag(s)	OV, Z, AC, C, SC
ADDM A,[m]	Add ACC to Data Memory
Description	The contents of the specified Data Memory and the Accumulator are added. The result is stored in the specified Data Memory.
Operation	$[m] \leftarrow ACC + [m]$
Affected flag(s)	OV, Z, AC, C, SC
AND A,[m]	Logical AND Data Memory to ACC
Description	Data in the Accumulator and the specified Data Memory perform a bitwise logical AND operation. The result is stored in the Accumulator.
Operation	$ACC \leftarrow ACC \text{ "AND" } [m]$
Affected flag(s)	Z
AND A,x	Logical AND immediate data to ACC
Description	Data in the Accumulator and the specified immediate data perform a bit wise logical AND operation. The result is stored in the Accumulator.
Operation	$ACC \leftarrow ACC \text{ "AND" } x$
Affected flag(s)	Z
ANDM A,[m]	Logical AND ACC to Data Memory
Description	Data in the specified Data Memory and the Accumulator perform a bitwise logical AND operation. The result is stored in the Data Memory.
Operation	$[m] \leftarrow ACC \text{ "AND" } [m]$
Affected flag(s)	Z

CALL addr	Subroutine call
Description	Unconditionally calls a subroutine at the specified address. The Program Counter then increments by 1 to obtain the address of the next instruction which is then pushed onto the stack. The specified address is then loaded and the program continues execution from this new address. As this instruction requires an additional operation, it is a two cycle instruction.
Operation	Stack ← Program Counter + 1 Program Counter ← addr
Affected flag(s)	None
CLR [m]	Clear Data Memory
Description	Each bit of the specified Data Memory is cleared to 0.
Operation	[m] ← 00H
Affected flag(s)	None
CLR [m].i	Clear bit of Data Memory
Description	Bit i of the specified Data Memory is cleared to 0.
Operation	[m].i ← 0
Affected flag(s)	None
CLR WDT	Clear Watchdog Timer
Description	The TO, PDF flags and the WDT are all cleared.
Operation	WDT cleared TO ← 0 PDF ← 0
Affected flag(s)	TO, PDF
CPL [m]	Complement Data Memory
Description	Each bit of the specified Data Memory is logically complemented (1's complement). Bits which previously contained a 1 are changed to 0 and vice versa.
Operation	[m] ← $\overline{[m]}$
Affected flag(s)	Z
CPLA [m]	Complement Data Memory with result in ACC
Description	Each bit of the specified Data Memory is logically complemented (1's complement). Bits which previously contained a 1 are changed to 0 and vice versa. The complemented result is stored in the Accumulator and the contents of the Data Memory remain unchanged.
Operation	ACC ← $\overline{[m]}$
Affected flag(s)	Z
DAA [m]	Decimal-Adjust ACC for addition with result in Data Memory
Description	Convert the contents of the Accumulator value to a BCD (Binary Coded Decimal) value resulting from the previous addition of two BCD variables. If the low nibble is greater than 9 or if AC flag is set, then a value of 6 will be added to the low nibble. Otherwise the low nibble remains unchanged. If the high nibble is greater than 9 or if the C flag is set, then a value of 6 will be added to the high nibble. Essentially, the decimal conversion is performed by adding 00H, 06H, 60H or 66H depending on the Accumulator and flag conditions. Only the C flag may be affected by this instruction which indicates that if the original BCD sum is greater than 100, it allows multiple precision decimal addition.
Operation	[m] ← ACC + 00H or [m] ← ACC + 06H or [m] ← ACC + 60H or [m] ← ACC + 66H
Affected flag(s)	C

DEC [m]	Decrement Data Memory
Description	Data in the specified Data Memory is decremented by 1.
Operation	$[m] \leftarrow [m] - 1$
Affected flag(s)	Z
DECA [m]	Decrement Data Memory with result in ACC
Description	Data in the specified Data Memory is decremented by 1. The result is stored in the Accumulator. The contents of the Data Memory remain unchanged.
Operation	$ACC \leftarrow [m] - 1$
Affected flag(s)	Z
HALT	Enter power down mode
Description	This instruction stops the program execution and turns off the system clock. The contents of the Data Memory and registers are retained. The WDT and prescaler are cleared. The power down flag PDF is set and the WDT time-out flag TO is cleared.
Operation	$TO \leftarrow 0$ $PDF \leftarrow 1$
Affected flag(s)	TO, PDF
INC [m]	Increment Data Memory
Description	Data in the specified Data Memory is incremented by 1.
Operation	$[m] \leftarrow [m] + 1$
Affected flag(s)	Z
INCA [m]	Increment Data Memory with result in ACC
Description	Data in the specified Data Memory is incremented by 1. The result is stored in the Accumulator. The contents of the Data Memory remain unchanged.
Operation	$ACC \leftarrow [m] + 1$
Affected flag(s)	Z
JMP addr	Jump unconditionally
Description	The contents of the Program Counter are replaced with the specified address. Program execution then continues from this new address. As this requires the insertion of a dummy instruction while the new address is loaded, it is a two cycle instruction.
Operation	Program Counter \leftarrow addr
Affected flag(s)	None
MOV A,[m]	Move Data Memory to ACC
Description	The contents of the specified Data Memory are copied to the Accumulator.
Operation	$ACC \leftarrow [m]$
Affected flag(s)	None
MOV A,x	Move immediate data to ACC
Description	The immediate data specified is loaded into the Accumulator.
Operation	$ACC \leftarrow x$
Affected flag(s)	None
MOV [m],A	Move ACC to Data Memory
Description	The contents of the Accumulator are copied to the specified Data Memory.
Operation	$[m] \leftarrow ACC$
Affected flag(s)	None

NOP	No operation
Description	No operation is performed. Execution continues with the next instruction.
Operation	No operation
Affected flag(s)	None
OR A,[m]	Logical OR Data Memory to ACC
Description	Data in the Accumulator and the specified Data Memory perform a bitwise logical OR operation. The result is stored in the Accumulator.
Operation	ACC ← ACC "OR" [m]
Affected flag(s)	Z
OR A,x	Logical OR immediate data to ACC
Description	Data in the Accumulator and the specified immediate data perform a bitwise logical OR operation. The result is stored in the Accumulator.
Operation	ACC ← ACC "OR" x
Affected flag(s)	Z
ORM A,[m]	Logical OR ACC to Data Memory
Description	Data in the specified Data Memory and the Accumulator perform a bitwise logical OR operation. The result is stored in the Data Memory.
Operation	[m] ← ACC "OR" [m]
Affected flag(s)	Z
RET	Return from subroutine
Description	The Program Counter is restored from the stack. Program execution continues at the restored address.
Operation	Program Counter ← Stack
Affected flag(s)	None
RET A,x	Return from subroutine and load immediate data to ACC
Description	The Program Counter is restored from the stack and the Accumulator loaded with the specified immediate data. Program execution continues at the restored address.
Operation	Program Counter ← Stack ACC ← x
Affected flag(s)	None
RETI	Return from interrupt
Description	The Program Counter is restored from the stack and the interrupts are re-enabled by setting the EMI bit. EMI is the master interrupt global enable bit. If an interrupt was pending when the RETI instruction is executed, the pending Interrupt routine will be processed before returning to the main program.
Operation	Program Counter ← Stack EMI ← 1
Affected flag(s)	None
RL [m]	Rotate Data Memory left
Description	The contents of the specified Data Memory are rotated left by 1 bit with bit 7 rotated into bit 0.
Operation	[m].(i+1) ← [m].i; (i=0~6) [m].0 ← [m].7
Affected flag(s)	None

RLA [m]	Rotate Data Memory left with result in ACC
Description	The contents of the specified Data Memory are rotated left by 1 bit with bit 7 rotated into bit 0. The rotated result is stored in the Accumulator and the contents of the Data Memory remain unchanged.
Operation	$ACC.(i+1) \leftarrow [m].i; (i=0\sim 6)$ $ACC.0 \leftarrow [m].7$
Affected flag(s)	None
RLC [m]	Rotate Data Memory left through Carry
Description	The contents of the specified Data Memory and the carry flag are rotated left by 1 bit. Bit 7 replaces the Carry bit and the original carry flag is rotated into bit 0.
Operation	$[m].(i+1) \leftarrow [m].i; (i=0\sim 6)$ $[m].0 \leftarrow C$ $C \leftarrow [m].7$
Affected flag(s)	C
RLCA [m]	Rotate Data Memory left through Carry with result in ACC
Description	Data in the specified Data Memory and the carry flag are rotated left by 1 bit. Bit 7 replaces the Carry bit and the original carry flag is rotated into the bit 0. The rotated result is stored in the Accumulator and the contents of the Data Memory remain unchanged.
Operation	$ACC.(i+1) \leftarrow [m].i; (i=0\sim 6)$ $ACC.0 \leftarrow C$ $C \leftarrow [m].7$
Affected flag(s)	C
RR [m]	Rotate Data Memory right
Description	The contents of the specified Data Memory are rotated right by 1 bit with bit 0 rotated into bit 7.
Operation	$[m].i \leftarrow [m].(i+1); (i=0\sim 6)$ $[m].7 \leftarrow [m].0$
Affected flag(s)	None
RRA [m]	Rotate Data Memory right with result in ACC
Description	Data in the specified Data Memory is rotated right by 1 bit with bit 0 rotated into bit 7. The rotated result is stored in the Accumulator and the contents of the Data Memory remain unchanged.
Operation	$ACC.i \leftarrow [m].(i+1); (i=0\sim 6)$ $ACC.7 \leftarrow [m].0$
Affected flag(s)	None
RRC [m]	Rotate Data Memory right through Carry
Description	The contents of the specified Data Memory and the carry flag are rotated right by 1 bit. Bit 0 replaces the Carry bit and the original carry flag is rotated into bit 7.
Operation	$[m].i \leftarrow [m].(i+1); (i=0\sim 6)$ $[m].7 \leftarrow C$ $C \leftarrow [m].0$
Affected flag(s)	C

RRCA [m]	Rotate Data Memory right through Carry with result in ACC
Description	Data in the specified Data Memory and the carry flag are rotated right by 1 bit. Bit 0 replaces the Carry bit and the original carry flag is rotated into bit 7. The rotated result is stored in the Accumulator and the contents of the Data Memory remain unchanged.
Operation	$ACC.i \leftarrow [m].(i+1); (i=0\sim6)$ $ACC.7 \leftarrow C$ $C \leftarrow [m].0$
Affected flag(s)	C
SBC A,[m]	Subtract Data Memory from ACC with Carry
Description	The contents of the specified Data Memory and the complement of the carry flag are subtracted from the Accumulator. The result is stored in the Accumulator. Note that if the result of subtraction is negative, the C flag will be cleared to 0, otherwise if the result is positive or zero, the C flag will be set to 1.
Operation	$ACC \leftarrow ACC - [m] - \bar{C}$
Affected flag(s)	OV, Z, AC, C, SC, CZ
SBC A, x	Subtract immediate data from ACC with Carry
Description	The immediate data and the complement of the carry flag are subtracted from the Accumulator. The result is stored in the Accumulator. Note that if the result of subtraction is negative, the C flag will be cleared to 0, otherwise if the result is positive or zero, the C flag will be set to 1.
Operation	$ACC \leftarrow ACC - [m] - \bar{C}$
Affected flag(s)	OV, Z, AC, C, SC, CZ
SBCM A,[m]	Subtract Data Memory from ACC with Carry and result in Data Memory
Description	The contents of the specified Data Memory and the complement of the carry flag are subtracted from the Accumulator. The result is stored in the Data Memory. Note that if the result of subtraction is negative, the C flag will be cleared to 0, otherwise if the result is positive or zero, the C flag will be set to 1.
Operation	$[m] \leftarrow ACC - [m] - \bar{C}$
Affected flag(s)	OV, Z, AC, C, SC, CZ
SDZ [m]	Skip if decrement Data Memory is 0
Description	The contents of the specified Data Memory are first decremented by 1. If the result is 0 the following instruction is skipped. As this requires the insertion of a dummy instruction while the next instruction is fetched, it is a two cycle instruction. If the result is not 0 the program proceeds with the following instruction.
Operation	$[m] \leftarrow [m] - 1$ Skip if $[m]=0$
Affected flag(s)	None
SDZA [m]	Skip if decrement Data Memory is zero with result in ACC
Description	The contents of the specified Data Memory are first decremented by 1. If the result is 0, the following instruction is skipped. The result is stored in the Accumulator but the specified Data Memory contents remain unchanged. As this requires the insertion of a dummy instruction while the next instruction is fetched, it is a two cycle instruction. If the result is not 0, the program proceeds with the following instruction.
Operation	$ACC \leftarrow [m] - 1$ Skip if $ACC=0$
Affected flag(s)	None

SET [m]	Set Data Memory
Description	Each bit of the specified Data Memory is set to 1.
Operation	$[m] \leftarrow FFH$
Affected flag(s)	None
SET [m].i	Set bit of Data Memory
Description	Bit i of the specified Data Memory is set to 1.
Operation	$[m].i \leftarrow 1$
Affected flag(s)	None
SIZ [m]	Skip if increment Data Memory is 0
Description	The contents of the specified Data Memory are first incremented by 1. If the result is 0, the following instruction is skipped. As this requires the insertion of a dummy instruction while the next instruction is fetched, it is a two cycle instruction. If the result is not 0 the program proceeds with the following instruction.
Operation	$[m] \leftarrow [m] + 1$ Skip if $[m]=0$
Affected flag(s)	None
SIZA [m]	Skip if increment Data Memory is zero with result in ACC
Description	The contents of the specified Data Memory are first incremented by 1. If the result is 0, the following instruction is skipped. The result is stored in the Accumulator but the specified Data Memory contents remain unchanged. As this requires the insertion of a dummy instruction while the next instruction is fetched, it is a two cycle instruction. If the result is not 0 the program proceeds with the following instruction.
Operation	$ACC \leftarrow [m] + 1$ Skip if $ACC=0$
Affected flag(s)	None
SNZ [m].i	Skip if bit i of Data Memory is not 0
Description	If bit i of the specified Data Memory is not 0, the following instruction is skipped. As this requires the insertion of a dummy instruction while the next instruction is fetched, it is a two cycle instruction. If the result is 0 the program proceeds with the following instruction.
Operation	Skip if $[m].i \neq 0$
Affected flag(s)	None
SNZ [m]	Skip if Data Memory is not 0
Description	The contents of the specified Data Memory are read out and then written back to the specified Data Memory again. If the specified Data Memory is not 0, the following instruction is skipped. As this requires the insertion of a dummy instruction while the next instruction is fetched, it is a two cycle instruction. If the result is 0 the program proceeds with the following instruction.
Operation	Skip if $[m] \neq 0$
Affected flag(s)	None
SUB A,[m]	Subtract Data Memory from ACC
Description	The specified Data Memory is subtracted from the contents of the Accumulator. The result is stored in the Accumulator. Note that if the result of subtraction is negative, the C flag will be cleared to 0, otherwise if the result is positive or zero, the C flag will be set to 1.
Operation	$ACC \leftarrow ACC - [m]$
Affected flag(s)	OV, Z, AC, C, SC, CZ

SUBM A,[m]	Subtract Data Memory from ACC with result in Data Memory
Description	The specified Data Memory is subtracted from the contents of the Accumulator. The result is stored in the Data Memory. Note that if the result of subtraction is negative, the C flag will be cleared to 0, otherwise if the result is positive or zero, the C flag will be set to 1.
Operation	$[m] \leftarrow ACC - [m]$
Affected flag(s)	OV, Z, AC, C, SC, CZ
SUB A,x	Subtract immediate data from ACC
Description	The immediate data specified by the code is subtracted from the contents of the Accumulator. The result is stored in the Accumulator. Note that if the result of subtraction is negative, the C flag will be cleared to 0, otherwise if the result is positive or zero, the C flag will be set to 1.
Operation	$ACC \leftarrow ACC - x$
Affected flag(s)	OV, Z, AC, C, SC, CZ
SWAP [m]	Swap nibbles of Data Memory
Description	The low-order and high-order nibbles of the specified Data Memory are interchanged.
Operation	$[m].3 \sim [m].0 \leftrightarrow [m].7 \sim [m].4$
Affected flag(s)	None
SWAPA [m]	Swap nibbles of Data Memory with result in ACC
Description	The low-order and high-order nibbles of the specified Data Memory are interchanged. The result is stored in the Accumulator. The contents of the Data Memory remain unchanged.
Operation	$ACC.3 \sim ACC.0 \leftarrow [m].7 \sim [m].4$ $ACC.7 \sim ACC.4 \leftarrow [m].3 \sim [m].0$
Affected flag(s)	None
SZ [m]	Skip if Data Memory is 0
Description	The contents of the specified Data Memory are read out and then written back to the specified Data Memory again. If the contents of the specified Data Memory is 0, the following instruction is skipped. As this requires the insertion of a dummy instruction while the next instruction is fetched, it is a two cycle instruction. If the result is not 0 the program proceeds with the following instruction.
Operation	Skip if $[m]=0$
Affected flag(s)	None
SZA [m]	Skip if Data Memory is 0 with data movement to ACC
Description	The contents of the specified Data Memory are copied to the Accumulator. If the value is zero, the following instruction is skipped. As this requires the insertion of a dummy instruction while the next instruction is fetched, it is a two cycle instruction. If the result is not 0 the program proceeds with the following instruction.
Operation	$ACC \leftarrow [m]$ Skip if $[m]=0$
Affected flag(s)	None
SZ [m].i	Skip if bit i of Data Memory is 0
Description	If bit i of the specified Data Memory is 0, the following instruction is skipped. As this requires the insertion of a dummy instruction while the next instruction is fetched, it is a two cycle instruction. If the result is not 0, the program proceeds with the following instruction.
Operation	Skip if $[m].i=0$
Affected flag(s)	None

TABRD [m]	Read table (specific page) to TBLH and Data Memory
Description	The low byte of the program code (specific page) addressed by the table pointer (TBLP and TBHP) is moved to the specified Data Memory and the high byte moved to TBLH.
Operation	[m] ← program code (low byte) TBLH ← program code (high byte)
Affected flag(s)	None
TABRDL [m]	Read table (last page) to TBLH and Data Memory
Description	The low byte of the program code (last page) addressed by the table pointer (TBLP) is moved to the specified Data Memory and the high byte moved to TBLH.
Operation	[m] ← program code (low byte) TBLH ← program code (high byte)
Affected flag(s)	None
ITABRD [m]	Increment table pointer low byte first and read table (specific page) to TBLH and Data Memory
Description	Increment table pointer low byte, TBLP, first and then the program code (specific page) addressed by the table pointer (TBHP and TBLP) is moved to the specified Data Memory and the high byte moved to TBLH.
Operation	[m] ← program code (low byte) TBLH ← program code (high byte)
Affected flag(s)	None
ITABRDL [m]	Increment table pointer low byte first and read table (last page) to TBLH and Data Memory
Description	Increment table pointer low byte, TBLP, first and then the low byte of the program code (last page) addressed by the table pointer (TBLP) is moved to the specified Data Memory and the high byte moved to TBLH.
Operation	[m] ← program code (low byte) TBLH ← program code (high byte)
Affected flag(s)	None
XOR A,[m]	Logical XOR Data Memory to ACC
Description	Data in the Accumulator and the specified Data Memory perform a bitwise logical XOR operation. The result is stored in the Accumulator.
Operation	ACC ← ACC "XOR" [m]
Affected flag(s)	Z
XORM A,[m]	Logical XOR ACC to Data Memory
Description	Data in the specified Data Memory and the Accumulator perform a bitwise logical XOR operation. The result is stored in the Data Memory.
Operation	[m] ← ACC "XOR" [m]
Affected flag(s)	Z
XOR A,x	Logical XOR immediate data to ACC
Description	Data in the Accumulator and the specified immediate data perform a bitwise logical XOR operation. The result is stored in the Accumulator.
Operation	ACC ← ACC "XOR" x
Affected flag(s)	Z

Extended Instruction Definition

The extended instructions are used to directly access the data stored in any data memory sections.

LADC A,[m]	Add Data Memory to ACC with Carry
Description	The contents of the specified Data Memory, Accumulator and the carry flag are added. The result is stored in the Accumulator.
Operation	$ACC \leftarrow ACC + [m] + C$
Affected flag(s)	OV, Z, AC, C, SC
LADCM A,[m]	Add ACC to Data Memory with Carry
Description	The contents of the specified Data Memory, Accumulator and the carry flag are added. The result is stored in the specified Data Memory.
Operation	$[m] \leftarrow ACC + [m] + C$
Affected flag(s)	OV, Z, AC, C, SC
LADD A,[m]	Add Data Memory to ACC
Description	The contents of the specified Data Memory and the Accumulator are added. The result is stored in the Accumulator.
Operation	$ACC \leftarrow ACC + [m]$
Affected flag(s)	OV, Z, AC, C, SC
LADDM A,[m]	Add ACC to Data Memory
Description	The contents of the specified Data Memory and the Accumulator are added. The result is stored in the specified Data Memory.
Operation	$[m] \leftarrow ACC + [m]$
Affected flag(s)	OV, Z, AC, C, SC
LAND A,[m]	Logical AND Data Memory to ACC
Description	Data in the Accumulator and the specified Data Memory perform a bitwise logical AND operation. The result is stored in the Accumulator.
Operation	$ACC \leftarrow ACC \text{ "AND" } [m]$
Affected flag(s)	Z
LANDM A,[m]	Logical AND ACC to Data Memory
Description	Data in the specified Data Memory and the Accumulator perform a bitwise logical AND operation. The result is stored in the Data Memory.
Operation	$[m] \leftarrow ACC \text{ "AND" } [m]$
Affected flag(s)	Z
LCLR [m]	Clear Data Memory
Description	Each bit of the specified Data Memory is cleared to 0.
Operation	$[m] \leftarrow 00H$
Affected flag(s)	None
LCLR [m].i	Clear bit of Data Memory
Description	Bit i of the specified Data Memory is cleared to 0.
Operation	$[m].i \leftarrow 0$
Affected flag(s)	None

LCPL [m]	Complement Data Memory
Description	Each bit of the specified Data Memory is logically complemented (1's complement). Bits which previously contained a 1 are changed to 0 and vice versa.
Operation	$[m] \leftarrow \overline{[m]}$
Affected flag(s)	Z
LCPLA [m]	Complement Data Memory with result in ACC
Description	Each bit of the specified Data Memory is logically complemented (1's complement). Bits which previously contained a 1 are changed to 0 and vice versa. The complemented result is stored in the Accumulator and the contents of the Data Memory remain unchanged.
Operation	$ACC \leftarrow \overline{[m]}$
Affected flag(s)	Z
LDAA [m]	Decimal-Adjust ACC for addition with result in Data Memory
Description	Convert the contents of the Accumulator value to a BCD (Binary Coded Decimal) value resulting from the previous addition of two BCD variables. If the low nibble is greater than 9 or if AC flag is set, then a value of 6 will be added to the low nibble. Otherwise the low nibble remains unchanged. If the high nibble is greater than 9 or if the C flag is set, then a value of 6 will be added to the high nibble. Essentially, the decimal conversion is performed by adding 00H, 06H, 60H or 66H depending on the Accumulator and flag conditions. Only the C flag may be affected by this instruction which indicates that if the original BCD sum is greater than 100, it allows multiple precision decimal addition.
Operation	$[m] \leftarrow ACC + 00H$ or $[m] \leftarrow ACC + 06H$ or $[m] \leftarrow ACC + 60H$ or $[m] \leftarrow ACC + 66H$
Affected flag(s)	C
LDEC [m]	Decrement Data Memory
Description	Data in the specified Data Memory is decremented by 1.
Operation	$[m] \leftarrow [m] - 1$
Affected flag(s)	Z
LDECA [m]	Decrement Data Memory with result in ACC
Description	Data in the specified Data Memory is decremented by 1. The result is stored in the Accumulator. The contents of the Data Memory remain unchanged.
Operation	$ACC \leftarrow [m] - 1$
Affected flag(s)	Z
LINC [m]	Increment Data Memory
Description	Data in the specified Data Memory is incremented by 1.
Operation	$[m] \leftarrow [m] + 1$
Affected flag(s)	Z
LINCA [m]	Increment Data Memory with result in ACC
Description	Data in the specified Data Memory is incremented by 1. The result is stored in the Accumulator. The contents of the Data Memory remain unchanged.
Operation	$ACC \leftarrow [m] + 1$
Affected flag(s)	Z

LMOV A,[m]	Move Data Memory to ACC
Description	The contents of the specified Data Memory are copied to the Accumulator.
Operation	$ACC \leftarrow [m]$
Affected flag(s)	None
LMOV [m],A	Move ACC to Data Memory
Description	The contents of the Accumulator are copied to the specified Data Memory.
Operation	$[m] \leftarrow ACC$
Affected flag(s)	None
LOR A,[m]	Logical OR Data Memory to ACC
Description	Data in the Accumulator and the specified Data Memory perform a bitwise logical OR operation. The result is stored in the Accumulator.
Operation	$ACC \leftarrow ACC \text{ "OR" } [m]$
Affected flag(s)	Z
LORM A,[m]	Logical OR ACC to Data Memory
Description	Data in the specified Data Memory and the Accumulator perform a bitwise logical OR operation. The result is stored in the Data Memory.
Operation	$[m] \leftarrow ACC \text{ "OR" } [m]$
Affected flag(s)	Z
LRL [m]	Rotate Data Memory left
Description	The contents of the specified Data Memory are rotated left by 1 bit with bit 7 rotated into bit 0.
Operation	$[m].(i+1) \leftarrow [m].i; (i=0\sim6)$ $[m].0 \leftarrow [m].7$
Affected flag(s)	None
LRLA [m]	Rotate Data Memory left with result in ACC
Description	The contents of the specified Data Memory are rotated left by 1 bit with bit 7 rotated into bit 0. The rotated result is stored in the Accumulator and the contents of the Data Memory remain unchanged.
Operation	$ACC.(i+1) \leftarrow [m].i; (i=0\sim6)$ $ACC.0 \leftarrow [m].7$
Affected flag(s)	None
LRLC [m]	Rotate Data Memory left through Carry
Description	The contents of the specified Data Memory and the carry flag are rotated left by 1 bit. Bit 7 replaces the Carry bit and the original carry flag is rotated into bit 0.
Operation	$[m].(i+1) \leftarrow [m].i; (i=0\sim6)$ $[m].0 \leftarrow C$ $C \leftarrow [m].7$
Affected flag(s)	C
LRLCA [m]	Rotate Data Memory left through Carry with result in ACC
Description	Data in the specified Data Memory and the carry flag are rotated left by 1 bit. Bit 7 replaces the Carry bit and the original carry flag is rotated into the bit 0. The rotated result is stored in the Accumulator and the contents of the Data Memory remain unchanged.
Operation	$ACC.(i+1) \leftarrow [m].i; (i=0\sim6)$ $ACC.0 \leftarrow C$ $C \leftarrow [m].7$
Affected flag(s)	C

LRR [m]	Rotate Data Memory right
Description	The contents of the specified Data Memory are rotated right by 1 bit with bit 0 rotated into bit 7.
Operation	$[m].i \leftarrow [m].(i+1); (i=0\sim 6)$ $[m].7 \leftarrow [m].0$
Affected flag(s)	None
LRRRA [m]	Rotate Data Memory right with result in ACC
Description	Data in the specified Data Memory is rotated right by 1 bit with bit 0 rotated into bit 7. The rotated result is stored in the Accumulator and the contents of the Data Memory remain unchanged.
Operation	$ACC.i \leftarrow [m].(i+1); (i=0\sim 6)$ $ACC.7 \leftarrow [m].0$
Affected flag(s)	None
LRRRC [m]	Rotate Data Memory right through Carry
Description	The contents of the specified Data Memory and the carry flag are rotated right by 1 bit. Bit 0 replaces the Carry bit and the original carry flag is rotated into bit 7.
Operation	$[m].i \leftarrow [m].(i+1); (i=0\sim 6)$ $[m].7 \leftarrow C$ $C \leftarrow [m].0$
Affected flag(s)	C
LRRCA [m]	Rotate Data Memory right through Carry with result in ACC
Description	Data in the specified Data Memory and the carry flag are rotated right by 1 bit. Bit 0 replaces the Carry bit and the original carry flag is rotated into bit 7. The rotated result is stored in the Accumulator and the contents of the Data Memory remain unchanged.
Operation	$ACC.i \leftarrow [m].(i+1); (i=0\sim 6)$ $ACC.7 \leftarrow C$ $C \leftarrow [m].0$
Affected flag(s)	C
LSBC A,[m]	Subtract Data Memory from ACC with Carry
Description	The contents of the specified Data Memory and the complement of the carry flag are subtracted from the Accumulator. The result is stored in the Accumulator. Note that if the result of subtraction is negative, the C flag will be cleared to 0, otherwise if the result is positive or zero, the C flag will be set to 1.
Operation	$ACC \leftarrow ACC - [m] - \bar{C}$
Affected flag(s)	OV, Z, AC, C, SC, CZ
LSBCM A,[m]	Subtract Data Memory from ACC with Carry and result in Data Memory
Description	The contents of the specified Data Memory and the complement of the carry flag are subtracted from the Accumulator. The result is stored in the Data Memory. Note that if the result of subtraction is negative, the C flag will be cleared to 0, otherwise if the result is positive or zero, the C flag will be set to 1.
Operation	$[m] \leftarrow ACC - [m] - \bar{C}$
Affected flag(s)	OV, Z, AC, C, SC, CZ

LSDZ [m]	Skip if decrement Data Memory is 0
Description	The contents of the specified Data Memory are first decremented by 1. If the result is 0 the following instruction is skipped. As this requires the insertion of a dummy instruction while the next instruction is fetched, it is a three cycle instruction. If the result is not 0 the program proceeds with the following instruction.
Operation	$[m] \leftarrow [m] - 1$ Skip if $[m]=0$
Affected flag(s)	None
LSDZA [m]	Skip if decrement Data Memory is zero with result in ACC
Description	The contents of the specified Data Memory are first decremented by 1. If the result is 0, the following instruction is skipped. The result is stored in the Accumulator but the specified Data Memory contents remain unchanged. As this requires the insertion of a dummy instruction while the next instruction is fetched, it is a three cycle instruction. If the result is not 0, the program proceeds with the following instruction.
Operation	$ACC \leftarrow [m] - 1$ Skip if $ACC=0$
Affected flag(s)	None
LSET [m]	Set Data Memory
Description	Each bit of the specified Data Memory is set to 1.
Operation	$[m] \leftarrow FFH$
Affected flag(s)	None
LSET [m].i	Set bit of Data Memory
Description	Bit i of the specified Data Memory is set to 1.
Operation	$[m].i \leftarrow 1$
Affected flag(s)	None
LSIZ [m]	Skip if increment Data Memory is 0
Description	The contents of the specified Data Memory are first incremented by 1. If the result is 0, the following instruction is skipped. As this requires the insertion of a dummy instruction while the next instruction is fetched, it is a three cycle instruction. If the result is not 0 the program proceeds with the following instruction.
Operation	$[m] \leftarrow [m] + 1$ Skip if $[m]=0$
Affected flag(s)	None
LSIZA [m]	Skip if increment Data Memory is zero with result in ACC
Description	The contents of the specified Data Memory are first incremented by 1. If the result is 0, the following instruction is skipped. The result is stored in the Accumulator but the specified Data Memory contents remain unchanged. As this requires the insertion of a dummy instruction while the next instruction is fetched, it is a three cycle instruction. If the result is not 0 the program proceeds with the following instruction.
Operation	$ACC \leftarrow [m] + 1$ Skip if $ACC=0$
Affected flag(s)	None
LSNZ [m].i	Skip if bit i of Data Memory is not 0
Description	If bit i of the specified Data Memory is not 0, the following instruction is skipped. As this requires the insertion of a dummy instruction while the next instruction is fetched, it is a three cycle instruction. If the result is 0 the program proceeds with the following instruction.
Operation	Skip if $[m].i \neq 0$
Affected flag(s)	None

LSNZ [m]	Skip if Data Memory is not 0
Description	The contents of the specified Data Memory are read out and then written to the specified Data Memory again. If the content of the specified Data Memory is not 0, the following instruction is skipped. As this requires the insertion of a dummy instruction while the next instruction is fetched, it is a three cycle instruction. If the result is 0 the program proceeds with the following instruction.
Operation	Skip if [m] ≠ 0
Affected flag(s)	None
LSUB A,[m]	Subtract Data Memory from ACC
Description	The specified Data Memory is subtracted from the contents of the Accumulator. The result is stored in the Accumulator. Note that if the result of subtraction is negative, the C flag will be cleared to 0, otherwise if the result is positive or zero, the C flag will be set to 1.
Operation	ACC ← ACC – [m]
Affected flag(s)	OV, Z, AC, C, SC, CZ
LSUBM A,[m]	Subtract Data Memory from ACC with result in Data Memory
Description	The specified Data Memory is subtracted from the contents of the Accumulator. The result is stored in the Data Memory. Note that if the result of subtraction is negative, the C flag will be cleared to 0, otherwise if the result is positive or zero, the C flag will be set to 1.
Operation	[m] ← ACC – [m]
Affected flag(s)	OV, Z, AC, C, SC, CZ
LSWAP [m]	Swap nibbles of Data Memory
Description	The low-order and high-order nibbles of the specified Data Memory are interchanged.
Operation	[m].3~[m].0 ↔ [m].7~[m].4
Affected flag(s)	None
LSWAPA [m]	Swap nibbles of Data Memory with result in ACC
Description	The low-order and high-order nibbles of the specified Data Memory are interchanged. The result is stored in the Accumulator. The contents of the Data Memory remain unchanged.
Operation	ACC.3~ACC.0 ← [m].7~[m].4 ACC.7~ACC.4 ← [m].3~[m].0
Affected flag(s)	None
LSZ [m]	Skip if Data Memory is 0
Description	The contents of the specified Data Memory are read out and then written to the specified Data Memory again. If the contents of the specified Data Memory is 0, the following instruction is skipped. As this requires the insertion of a dummy instruction while the next instruction is fetched, it is a three cycle instruction. If the result is not 0 the program proceeds with the following instruction.
Operation	Skip if [m]=0
Affected flag(s)	None
LSZA [m]	Skip if Data Memory is 0 with data movement to ACC
Description	The contents of the specified Data Memory are copied to the Accumulator. If the value is zero, the following instruction is skipped. As this requires the insertion of a dummy instruction while the next instruction is fetched, it is a three cycle instruction. If the result is not 0 the program proceeds with the following instruction.
Operation	ACC ← [m] Skip if [m]=0
Affected flag(s)	None

LSZ [m].i	Skip if bit i of Data Memory is 0
Description	If bit i of the specified Data Memory is 0, the following instruction is skipped. As this requires the insertion of a dummy instruction while the next instruction is fetched, it is a three cycle instruction. If the result is not 0, the program proceeds with the following instruction.
Operation	Skip if [m].i=0
Affected flag(s)	None
LTABRD [m]	Read table (specific page) to TBLH and Data Memory
Description	The low byte of the program code (specific page) addressed by the table pointer (TBHP and TBLP) is moved to the specified Data Memory and the high byte moved to TBLH.
Operation	[m] ← program code (low byte) TBLH ← program code (high byte)
Affected flag(s)	None
LTABRDL [m]	Read table (last page) to TBLH and Data Memory
Description	The low byte of the program code (last page) addressed by the table pointer (TBLP) is moved to the specified Data Memory and the high byte moved to TBLH.
Operation	[m] ← program code (low byte) TBLH ← program code (high byte)
Affected flag(s)	None
LITABRD [m]	Increment table pointer low byte first and read table (specific page) to TBLH and Data Memory
Description	Increment table pointer low byte, TBLP, first and then the program code (specific page) addressed by the table pointer (TBHP and TBLP) is moved to the specified Data Memory and the high byte moved to TBLH.
Operation	[m] ← program code (low byte) TBLH ← program code (high byte)
Affected flag(s)	None
LITABRDL [m]	Increment table pointer low byte first and read table (last page) to TBLH and Data Memory
Description	Increment table pointer low byte, TBLP, first and then the low byte of the program code (last page) addressed by the table pointer (TBLP) is moved to the specified Data Memory and the high byte moved to TBLH.
Operation	[m] ← program code (low byte) TBLH ← program code (high byte)
Affected flag(s)	None
LXOR A,[m]	Logical XOR Data Memory to ACC
Description	Data in the Accumulator and the specified Data Memory perform a bitwise logical XOR operation. The result is stored in the Accumulator.
Operation	ACC ← ACC "XOR" [m]
Affected flag(s)	Z
LXORM A,[m]	Logical XOR ACC to Data Memory
Description	Data in the specified Data Memory and the Accumulator perform a bitwise logical XOR operation. The result is stored in the Data Memory.
Operation	[m] ← ACC "XOR" [m]
Affected flag(s)	Z

Package Information

Note that the package information provided here is for consultation purposes only. As this information may be updated at regular intervals users are reminded to consult the [Holtek website](#) for the latest version of the [Package Information](#).

Additional supplementary information with regard to packaging is listed below. Click on the relevant section to be transferred to the relevant website page.

- [Package Information \(include Outline Dimensions, Product Tape and Reel Specifications\)](#)
- [The Operation Instruction of Packing Materials](#)
- [Carton information](#)

48-pin LQFP (7mm×7mm) Outline Dimensions

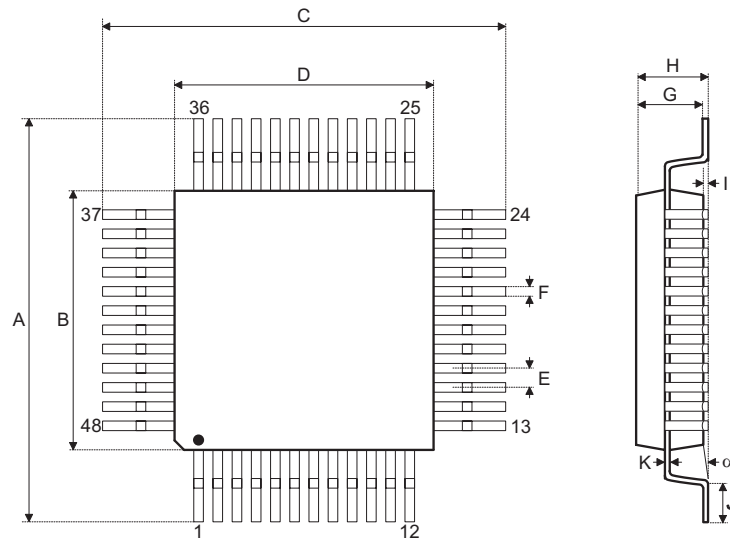

Symbol	Dimensions in inch		
	Min.	Nom.	Max.
A		0.354 BSC	
B		0.276 BSC	
C		0.354 BSC	
D		0.276 BSC	
E		0.020 BSC	
F	0.007	0.009	0.011
G	0.053	0.055	0.057
H	—	—	0.063
I	0.002	—	0.006
J	0.018	0.024	0.030
K	0.004	—	0.008
α	0°	—	7°

Symbol	Dimensions in mm		
	Min.	Nom.	Max.
A		9.00 BSC	
B		7.00 BSC	
C		9.00 BSC	
D		7.00 BSC	
E		0.50 BSC	
F	0.17	0.22	0.27
G	1.35	1.40	1.45
H	—	—	1.60
I	0.05	—	0.15
J	0.45	0.60	0.75
K	0.09	—	0.20
α	0°	—	7°

64-pin LQFP (7mm×7mm) Outline Dimensions

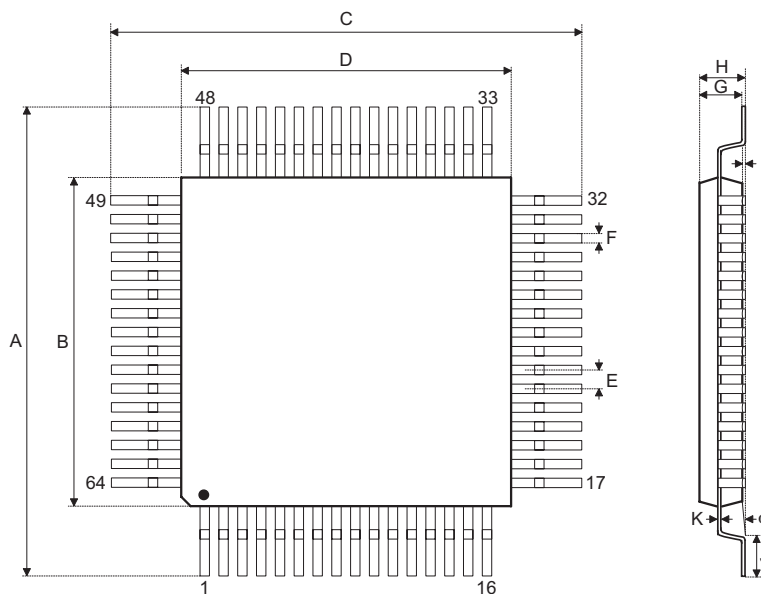

Symbol	Dimensions in inch		
	Min.	Nom.	Max.
A	0.472 BSC		
B	0.394 BSC		
C	0.472 BSC		
D	0.394 BSC		
E	0.020 BSC		
F	0.007	0.009	0.011
G	0.053	0.055	0.057
H	—	—	0.063
I	0.002	—	0.006
J	0.018	0.024	0.030
K	0.004	—	0.008
α	0°	—	7°

Symbol	Dimensions in mm		
	Min.	Nom.	Max.
A	12.00 BSC		
B	10.00 BSC		
C	12.00 BSC		
D	10.00 BSC		
E	0.50 BSC		
F	0.17	0.22	0.27
G	1.35	1.40	1.45
H	—	—	1.60
I	0.05	—	0.15
J	0.45	0.60	0.75
K	0.09	—	0.20
α	0°	—	7°

Copyright© 2023 by HOLTEK SEMICONDUCTOR INC. All Rights Reserved.

The information provided in this document has been produced with reasonable care and attention before publication, however, HOLTEK does not guarantee that the information is completely accurate. The information contained in this publication is provided for reference only and may be superseded by updates. HOLTEK disclaims any expressed, implied or statutory warranties, including but not limited to suitability for commercialization, satisfactory quality, specifications, characteristics, functions, fitness for a particular purpose, and non-infringement of any third-party's rights. HOLTEK disclaims all liability arising from the information and its application. In addition, HOLTEK does not recommend the use of HOLTEK's products where there is a risk of personal hazard due to malfunction or other reasons. HOLTEK hereby declares that it does not authorize the use of these products in life-saving, life-sustaining or safety critical components. Any use of HOLTEK's products in life-saving/sustaining or safety applications is entirely at the buyer's risk, and the buyer agrees to defend, indemnify and hold HOLTEK harmless from any damages, claims, suits, or expenses resulting from such use. The information provided in this document, including but not limited to the content, data, examples, materials, graphs, and trademarks, is the intellectual property of HOLTEK (and its licensors, where applicable) and is protected by copyright law and other intellectual property laws. No license, express or implied, to any intellectual property right, is granted by HOLTEK herein. HOLTEK reserves the right to revise the information described in the document at any time without prior notice. For the latest information, please contact us.