

**GigaDevice Semiconductor Inc.**

**GD32F101xx**

**Arm<sup>®</sup> Cortex<sup>®</sup>-M3 32-bit MCU**

**Datasheet**

Revision 2.9

(Jun. 2027)



## Table of Contents

Table of Contents.....	1
List of Figures .....	4
List of Tables .....	5
1. General description .....	7
2. Device overview .....	8
2.1. Device information.....	8
2.2. Block diagram.....	11
2.3. Pinouts and pin assignment.....	13
2.4. Memory map.....	17
2.5. Clock tree .....	21
2.6. Pin definitions .....	22
2.6.1. GD32F101Zx LQFP144 pin definitions .....	22
2.6.2. GD32F101Vx LQFP100 pin definitions.....	30
2.6.3. GD32F101Rx LQFP64 pin definitions.....	36
2.6.4. GD32F101Cx LQFP48 pin definitions.....	40
2.6.5. GD32F101Tx QFN36 pin definitions.....	43
3. Functional description .....	45
3.1. Arm® Cortex®-M3 core.....	45
3.2. On-chip memory.....	45
3.3. Clock, reset and supply management.....	46
3.4. Boot modes .....	46
3.5. Power saving modes.....	47
3.6. Analog to digital converter (ADC).....	47
3.7. DMA.....	48
3.8. General-purpose inputs/outputs (GPIOs).....	48
3.9. Timers and PWM generation.....	48
3.10. Real time clock (RTC) .....	49
3.11. Inter-integrated circuit (I2C).....	50
3.12. Serial peripheral interface (SPI).....	50
3.13. Universal synchronous asynchronous receiver transmitter (USART) .....	50



---

3.14.	External memory controller (EXMC).....	51
3.15.	Debug mode.....	51
3.16.	Package and operation temperature .....	51
4.	Electrical characteristics .....	52
4.1.	Absolute maximum ratings.....	52
4.2.	Operating conditions characteristics .....	52
4.3.	Power consumption .....	54
4.4.	EMC characteristics .....	57
4.5.	Power supply supervisor characteristics.....	57
4.6.	Electrical sensitivity.....	59
4.7.	External clock characteristics .....	59
4.8.	Internal clock characteristics .....	62
4.9.	PLL characteristics .....	64
4.10.	Memory characteristics .....	64
4.11.	NRST pin characteristics.....	65
4.12.	GPIO characteristics.....	65
4.13.	ADC characteristics.....	69
4.14.	Temperature sensor characteristics .....	71
4.15.	I2C characteristics .....	71
4.16.	SPI characteristics.....	73
4.17.	USART characteristics.....	74
4.18.	TIMER characteristics.....	75
4.19.	WDGT characteristics.....	75
4.20.	Parameter conditions .....	75
5.	Package information.....	77
5.1	LQFP144 package outline dimensions.....	77
5.2	LQFP100 package outline dimensions.....	79
5.3	LQFP64 package outline dimensions.....	81
5.4	LQFP48 package outline dimensions.....	83
5.5	QFN36 package outline dimensions.....	85
5.6	Thermal characteristics .....	87



---

<b>6. Ordering information .....</b>	<b>89</b>
<b>7. Revision history .....</b>	<b>91</b>



## List of Figures

Figure 2-1. GD32F101x4/6/8/B block diagram .....	11
Figure 2-2. GD32F101xC/D/E/F/G//K block diagram .....	12
Figure 2-3. GD32F101Zx LQFP144 pinouts.....	13
Figure 2-4. GD32F101Vx LQFP100 pinouts.....	14
Figure 2-5. GD32F101Rx LQFP64 pinouts .....	15
Figure 2-6. GD32F101Cx LQFP48 pinouts .....	16
Figure 2-7. GD32F101Tx QFN36 pinouts .....	16
Figure 2-8. GD32F101xx clock tree .....	21
Figure 4-1. Recommended power supply decoupling capacitors <sup>(1)(2)</sup> .....	53
Figure 4-2. Recommended external NRST pin circuit <sup>(1)</sup> .....	65
Figure 4-3. I2C bus timing diagram.....	72
Figure 4-4. SPI timing diagram - master mode.....	73
Figure 4-5. SPI timing diagram - slave mode .....	74
Figure 5-1. LQFP144 package outline .....	77
Figure 5-2. LQFP144 recommended footprint.....	78
Figure 5-3. LQFP100 package outline .....	79
Figure 5-4. LQFP100 recommended footprint.....	80
Figure 5-5. LQFP64 package outline .....	81
Figure 5-6. LQFP64 recommended footprint.....	82
Figure 5-7. LQFP48 package outline .....	83
Figure 5-8. LQFP48 recommended footprint.....	84
Figure 5-9. QFN36 package outline.....	85
Figure 5-10. QFN36 recommended footprint.....	86



## List of Tables

Table 2-1. GD32F101xx devices features and peripheral list .....	8
Table 2-2. GD32F101xx devices features and peripheral list (continued) .....	9
Table 2-3. GD32F101xx devices features and peripheral list (continued) .....	10
Table 2-4. GD32F101xx memory map .....	17
Table 2-5. GD32F101Zx LQFP144 pin definitions .....	22
Table 2-6. GD32F101Vx LQFP100 pin definitions .....	30
Table 2-7. GD32F101Rx LQFP64 pin definitions .....	36
Table 2-8. GD32F101Cx LQFP48 pin definitions .....	40
Table 2-9. GD32F101Tx QFN36 pin definitions .....	43
Table 4-1. Absolute maximum ratings <sup>(1)(4)</sup> .....	52
Table 4-2. DC operating conditions .....	52
Table 4-3. Clock frequency <sup>(1)</sup> .....	53
Table 4-4. Operating conditions at Power up/ Power down <sup>(1)</sup> .....	53
Table 4-5. Start-up timings of Operating conditions <sup>(1)(2)(3)</sup> (For GD32F101x4/6/8/B devices) .....	53
Table 4-6. Start-up timings of Operating conditions <sup>(1)(2)(3)</sup> (For GD32F101xC/D/E/F/G//K devices) .....	53
Table 4-7. Power saving mode wakeup timings characteristics <sup>(1)(2)</sup> (For GD32F101x4/6/8/B devices) .....	54
Table 4-8. Power saving mode wakeup timings characteristics <sup>(1)(2)</sup> (For GD32F101xC/D/E/F/G//K devices) .....	54
Table 4-9. Power consumption characteristics <sup>(2)(3)(4)(5)</sup> (For GD32F101x4/6/8/B devices) .....	54
Table 4-10. Power consumption characteristics <sup>(2)(3)(4)(5)</sup> (For GD32F101xC/D/E/F/G//K devices) .....	56
Table 4-11. EMS characteristics <sup>(1)</sup> .....	57
Table 4-12. Power supply supervisor characteristics (For GD32F101x4/6/8/B devices) .....	57
Table 4-13. Power supply supervisor characteristics (For GD32F101xC/D/E/F/G//K devices) .....	58
Table 4-14. ESD characteristics <sup>(1)</sup> .....	59
Table 4-15. Static latch-up characteristics <sup>(1)</sup> .....	59
Table 4-16. High speed external clock (HXTAL) generated from a crystal/ceramic characteristics (For GD32F101x4/6/8/B devices) .....	59
Table 4-17. High speed external clock (HXTAL) generated from a crystal/ceramic characteristics (For GD32F101xC/D/E/F/G//K devices) .....	60
Table 4-18. High speed external clock characteristics (HXTAL in bypass mode) .....	60
Table 4-19. Low speed external clock (LXTAL) generated from a crystal/ceramic characteristics (For GD32F101x4/6/8/B devices) .....	60
Table 4-20. Low speed external clock (LXTAL) generated from a crystal/ceramic characteristics (For GD32F101xC/D/E/F/G//K devices) .....	61
Table 4-21. Low speed external user clock characteristics (LXTAL in bypass mode) .....	62
Table 4-22. High speed internal clock (IRC8M) characteristics (For GD32F101x4/6/8/B devices) .....	62
Table 4-23. High speed internal clock (IRC8M) characteristics (For GD32F101xC/D/E/F/G//K devices) .....	62
Table 4-24. Low speed internal clock (IRC40K) characteristics (For GD32F101x4/6/8/B devices) .....	63



Table 4-25. Low speed internal clock (IRC40K) characteristics (For GD32F101xC/D/E/F/G/I/K devices).....	63
Table 4-26. PLL characteristics .....	64
Table 4-27. Flash memory characteristics (For GD32F101x4/6/8/B devices).....	64
Table 4-28. Flash memory characteristics (For GD32F101xC/D/E/F/G/I/K devices).....	64
Table 4-29. NRST pin characteristics .....	65
Table 4-30. I/O port DC characteristics <sup>(1)(3)</sup> (For GD32F101x4/6/8/B devices) .....	65
Table 4-31. I/O port DC characteristics <sup>(1)(3)</sup> (For GD32F101xC/D/E/F/G/I/K devices) .....	67
Table 4-32. I/O port AC characteristics <sup>(1)(2)(4)</sup> (For GD32F101x4/6/8/B devices).....	68
Table 4-33. I/O port AC characteristics <sup>(1)(2)(4)</sup> (For GD32F101xC/D/E/F/G/I/K devices).....	69
Table 4-34. ADC characteristics (For GD32F101x4/6/8/B devices) .....	69
Table 4-35. ADC characteristics(For GD32F101xC/D/E/F/G/I/K devices).....	70
Table 4-36. ADC $R_{AIN\ max}$ for $f_{ADC} = 14\ MHz$ (For GD32F101x4/6/8/B devices) .....	70
Table 4-37. ADC $R_{AIN\ max}$ for $f_{ADC} = 14\ MHz$ (For GD32F101xC/D/E/F/G/I/K devices) .....	71
Table 4-38. Temperature sensor characteristics <sup>(1)</sup> .....	71
Table 4-39. I2C characteristics <sup>(1)(2)</sup> .....	71
Table 4-40. Standard SPI characteristics <sup>(1)</sup> .....	73
Table 4-41. USART characteristics <sup>(1)</sup> .....	74
Table 4-42. TIMER characteristics <sup>(1)</sup> .....	75
Table 4-43. FWDGT min/max timeout period at 40 kHz (IRC40K) <sup>(1)</sup> .....	75
Table 4-44. WWDGT min-max timeout value at 54 MHz ( $f_{PCLK1}$ ) <sup>(1)</sup> .....	75
Table 5-1. LQFP144 package dimensions.....	77
Table 5-2. LQFP100 package dimensions.....	79
Table 5-3. LQFP64 package dimensions .....	81
Table 5-4. LQFP48 package dimensions .....	83
Table 5-5. QFN36 package dimensions.....	85
Table 5-6. Package thermal characteristics <sup>(1)</sup> .....	87
Table 6-1. Part ordering code for GD32F101xx devices .....	89
Table 7-1. Revision history.....	91

## 1. General description

The GD32F101xx device is a 32-bit general-purpose microcontroller based on the Arm® Cortex®-M3 RISC core with best ratio in terms of processing power, reduced power consumption and peripheral set. The Cortex®-M3 is a next generation processor core which is tightly coupled with a Nested Vectored Interrupt Controller (NVIC), SysTick timer and advanced debug support.

The GD32F101xx device incorporates the Arm® Cortex®-M3 32-bit processor core operating at 56 MHz frequency with Flash accesses zero wait states to obtain maximum efficiency. It provides up to 3 MB on-chip Flash memory and up to 80 KB SRAM memory. An extensive range of enhanced I/Os and peripherals connected to two APB buses. The devices offer up to two 12-bit ADCs, up to ten general-purpose 16-bit timers and two basic timers, as well as standard and advanced communication interfaces: up to three USARTs, two UARTs, three SPIs and two I2Cs.

The device operates from a 2.6 to 3.6 V power supply and available in –40 to +85 °C temperature range. Several power saving modes provide the flexibility for maximum optimization between wakeup latency and power consumption, an especially important consideration in low power applications.

The above features make the GD32F101xx devices suitable for a wide range of applications, especially in areas such as industrial control, user interface, power monitor and alarm systems, consumer and handheld equipment, touch panel, PC peripherals and so on.



## 2. Device overview

### 2.1. Device information

Table 2-1. GD32F101xx devices features and peripheral list

Part Number		GD32F101xx													
		T4	T6	T8	TB	C4	C6	C8	CB	R4	R6	R8	RB	V8	VB
Flash	Code Area (KB)	16	32	64	128	16	32	64	128	16	32	64	128	64	128
	Data Area (KB)	0	0	0	0	0	0	0	0	0	0	0	0	0	0
	Total (KB)	16	32	64	128	16	32	64	128	16	32	64	128	64	128
SRAM (KB)		4	6	10	16	4	6	10	16	4	6	10	16	10	16
Timers	GPTM(16 bit)	2 <small>(1-2)</small>	2 <small>(1-2)</small>	3 <small>(1-3)</small>	3 <small>(1-3)</small>	2 <small>(1-2)</small>	2 <small>(1-2)</small>	3 <small>(1-3)</small>	3 <small>(1-3)</small>	2 <small>(1-2)</small>	2 <small>(1-2)</small>	3 <small>(1-3)</small>	3 <small>(1-3)</small>	3 <small>(1-3)</small>	3 <small>(1-3)</small>
	SysTick	1	1	1	1	1	1	1	1	1	1	1	1	1	1
	Watchdog	2	2	2	2	2	2	2	2	2	2	2	2	2	2
	RTC	1	1	1	1	1	1	1	1	1	1	1	1	1	1
Connectivity	USART	2 <small>(0-1)</small>	2 <small>(0-1)</small>	2 <small>(0-1)</small>	2 <small>(0-1)</small>	2 <small>(0-1)</small>	2 <small>(0-1)</small>	3 <small>(0-2)</small>	3 <small>(0-2)</small>	2 <small>(0-1)</small>	2 <small>(0-1)</small>	3 <small>(0-2)</small>	3 <small>(0-2)</small>	3 <small>(0-2)</small>	3 <small>(0-2)</small>
	I2C	1 <small>(0)</small>	1 <small>(0)</small>	1 <small>(0)</small>	1 <small>(0)</small>	1 <small>(0)</small>	1 <small>(0)</small>	2 <small>(0-1)</small>	2 <small>(0-1)</small>	1 <small>(0)</small>	1 <small>(0)</small>	2 <small>(0-1)</small>	2 <small>(0-1)</small>	2 <small>(0-1)</small>	2 <small>(0-1)</small>
	SPI	1 <small>(0)</small>	1 <small>(0)</small>	1 <small>(0)</small>	1 <small>(0)</small>	1 <small>(0)</small>	1 <small>(0)</small>	2 <small>(0-1)</small>	2 <small>(0-1)</small>	1 <small>(0)</small>	1 <small>(0)</small>	2 <small>(0-1)</small>	2 <small>(0-1)</small>	2 <small>(0-1)</small>	2 <small>(0-1)</small>
GPIO		26	26	26	26	37	37	37	37	51	51	51	51	80	80
EXMC		0	0	0	0	0	0	0	0	0	0	0	0	1	1
EXTI		16	16	16	16	16	16	16	16	16	16	16	16	16	16
ADC	Units	1 <small>(0)</small>	1 <small>(0)</small>	1 <small>(0)</small>	1 <small>(0)</small>	1 <small>(0)</small>	1 <small>(0)</small>	1 <small>(0)</small>	1 <small>(0)</small>	1 <small>(0)</small>	1 <small>(0)</small>	1 <small>(0)</small>	1 <small>(0)</small>	1 <small>(0)</small>	1 <small>(0)</small>
	Channels	10	10	10	10	10	10	10	10	16	16	16	16	16	16
Package		QFN36				LQFP48				LQFP64				LQFP100	



Table 2-2. GD32F101xx devices features and peripheral list (continued)

Part Number		GD32F101xx														
		RC	RD	RE	RF	RG	RI	RK	VC	VD	VE	VF	VG	VI	VK	
Flash	Code Area (KB)	256	256	256	256	256	256	256	256	256	256	256	256	256	256	
	Data Area (KB)	0	128	256	512	768	1792	2816	0	128	256	512	768	1792	2816	
	Total (KB)	256	384	512	768	1024	2048	3072	256	384	512	768	1024	2048	3072	
SRAM (KB)		32	48	48	80	80	80	80	32	48	48	80	80	80	80	
Timers	GPTM(16 bit)	4 <small>(1-4)</small>	4 <small>(1-4)</small>	4 <small>(1-4)</small>	10 <small>(1-4,8-13)</small>	10 <small>(1-4,8-13)</small>	10 <small>(1-4,8-13)</small>	10 <small>(1-4,8-13)</small>	4 <small>(1-4)</small>	4 <small>(1-4)</small>	4 <small>(1-4)</small>	10 <small>(1-4,8-13)</small>	10 <small>(1-4,8-13)</small>	10 <small>(1-4,8-13)</small>	10 <small>(1-4,8-13)</small>	
	SysTick	1	1	1	1	1	1	1	1	1	1	1	1	1	1	
	Basic TM(16 bit)	2 <small>(5-6)</small>	2 <small>(5-6)</small>	2 <small>(5-6)</small>	2 <small>(5-6)</small>	2 <small>(5-6)</small>	2 <small>(5-6)</small>	2 <small>(5-6)</small>	2 <small>(5-6)</small>	2 <small>(5-6)</small>	2 <small>(5-6)</small>	2 <small>(5-6)</small>	2 <small>(5-6)</small>	2 <small>(5-6)</small>	2 <small>(5-6)</small>	2 <small>(5-6)</small>
	Watchdog	2	2	2	2	2	2	2	2	2	2	2	2	2	2	
	RTC	1	1	1	1	1	1	1	1	1	1	1	1	1	1	
Connectivity	USART	3 <small>(0-2)</small>	3 <small>(0-2)</small>	3 <small>(0-2)</small>	3 <small>(0-2)</small>	3 <small>(0-2)</small>	3 <small>(0-2)</small>	3 <small>(0-2)</small>	3 <small>(0-2)</small>	3 <small>(0-2)</small>	3 <small>(0-2)</small>	3 <small>(0-2)</small>	3 <small>(0-2)</small>	3 <small>(0-2)</small>	3 <small>(0-2)</small>	
	UART	2 <small>(3-4)</small>	2 <small>(3-4)</small>	2 <small>(3-4)</small>	2 <small>(3-4)</small>	2 <small>(3-4)</small>	2 <small>(3-4)</small>	2 <small>(3-4)</small>	2 <small>(3-4)</small>	2 <small>(3-4)</small>	2 <small>(3-4)</small>	2 <small>(3-4)</small>	2 <small>(3-4)</small>	2 <small>(3-4)</small>	2 <small>(3-4)</small>	
	I2C	2 <small>(0-1)</small>	2 <small>(0-1)</small>	2 <small>(0-1)</small>	2 <small>(0-1)</small>	2 <small>(0-1)</small>	2 <small>(0-1)</small>	2 <small>(0-1)</small>	2 <small>(0-1)</small>	2 <small>(0-1)</small>	2 <small>(0-1)</small>	2 <small>(0-1)</small>	2 <small>(0-1)</small>	2 <small>(0-1)</small>	2 <small>(0-1)</small>	
	SPI	3 <small>(0-2)</small>	3 <small>(0-2)</small>	3 <small>(0-2)</small>	3 <small>(0-2)</small>	3 <small>(0-2)</small>	3 <small>(0-2)</small>	3 <small>(0-2)</small>	3 <small>(0-2)</small>	3 <small>(0-2)</small>	3 <small>(0-2)</small>	3 <small>(0-2)</small>	3 <small>(0-2)</small>	3 <small>(0-2)</small>	3 <small>(0-2)</small>	
GPIO		51	51	51	51	51	51	51	80	80	80	80	80	80	80	
EXMC		0	0	0	0	0	0	0	1	1	1	1	1	1	1	
EXTI		16	16	16	16	16	16	16	16	16	16	16	16	16	16	
ADC	Units	1 <small>(0)</small>	1 <small>(0)</small>	1 <small>(0)</small>	2 <small>(0-1)</small>	2 <small>(0-1)</small>	2 <small>(0-1)</small>	2 <small>(0-1)</small>	1 <small>(0)</small>	1 <small>(0)</small>	1 <small>(0)</small>	2 <small>(0-1)</small>	2 <small>(0-1)</small>	2 <small>(0-1)</small>	2 <small>(0-1)</small>	
	Channels	16	16	16	16	16	16	16	16	16	16	16	16	16	16	
Package		LQFP64							LQFP100							

**Table 2-3. GD32F101xx devices features and peripheral list (continued)**

Part Number		GD32F101xx						
		ZC	ZD	ZE	ZF	ZG	ZI	ZK
Flash	Code Area (KB)	256	256	256	256	256	256	256
	Data Area (KB)	0	128	256	512	768	1792	2816
	Total (KB)	256	384	512	768	1024	2048	3072
SRAM (KB)		32	48	48	80	80	80	80
Timers	GPTM(16 bit)	4 <small>(1-4)</small>	4 <small>(1-4)</small>	4 <small>(1-4)</small>	10 <small>(1-4,8-13)</small>	10 <small>(1-4,8-13)</small>	10 <small>(1-4,8-13)</small>	10 <small>(1-4,8-13)</small>
	SysTick	1	1	1	1	1	1	1
	Basic TM(16 bit)	2 <small>(5-6)</small>	2 <small>(5-6)</small>	2 <small>(5-6)</small>	2 <small>(5-6)</small>	2 <small>(5-6)</small>	2 <small>(5-6)</small>	2 <small>(5-6)</small>
	Watchdog	2	2	2	2	2	2	2
	RTC	1	1	1	1	1	1	1
Connectivity	USART	3 <small>(0-2)</small>	3 <small>(0-2)</small>	3 <small>(0-2)</small>	3 <small>(0-2)</small>	3 <small>(0-2)</small>	3 <small>(0-2)</small>	3 <small>(0-2)</small>
	UART	2 <small>(3-4)</small>	2 <small>(3-4)</small>	2 <small>(3-4)</small>	2 <small>(3-4)</small>	2 <small>(3-4)</small>	2 <small>(3-4)</small>	2 <small>(3-4)</small>
	I2C	2 <small>(0-1)</small>	2 <small>(0-1)</small>	2 <small>(0-1)</small>	2 <small>(0-1)</small>	2 <small>(0-1)</small>	2 <small>(0-1)</small>	2 <small>(0-1)</small>
	SPI	3 <small>(0-2)</small>	3 <small>(0-2)</small>	3 <small>(0-2)</small>	3 <small>(0-2)</small>	3 <small>(0-2)</small>	3 <small>(0-2)</small>	3 <small>(0-2)</small>
GPIO		112	112	112	112	112	112	112
EXMC		1	1	1	1	1	1	1
EXTI		16	16	16	16	16	16	16
ADC	Units	1 <small>(0)</small>	1 <small>(0)</small>	1 <small>(0)</small>	2 <small>(0-1)</small>	2 <small>(0-1)</small>	2 <small>(0-1)</small>	2 <small>(0-1)</small>
	Channels	16	16	16	16	16	16	16
Package		LQFP144						

## 2.2. Block diagram

Figure 2-1. GD32F101x4/6/8/B block diagram

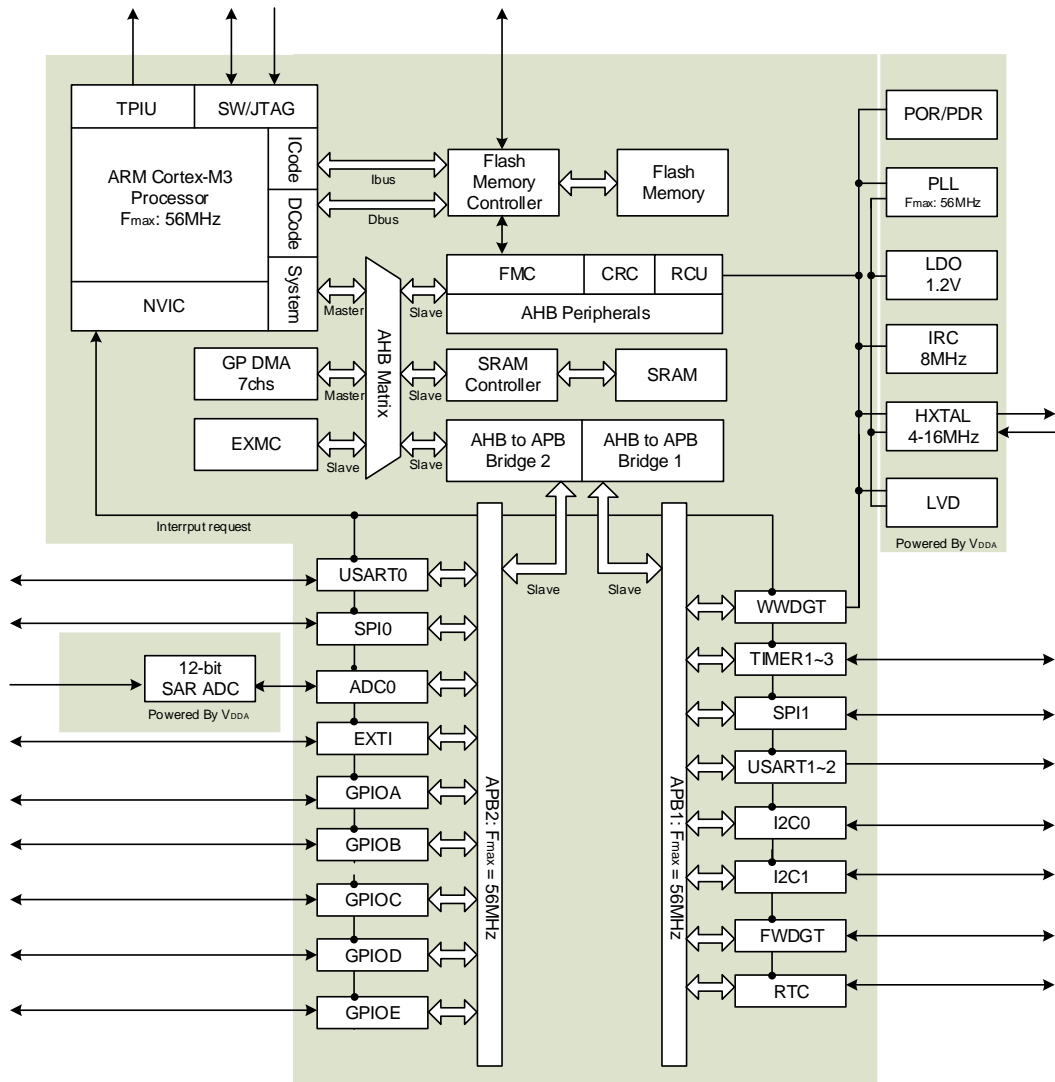
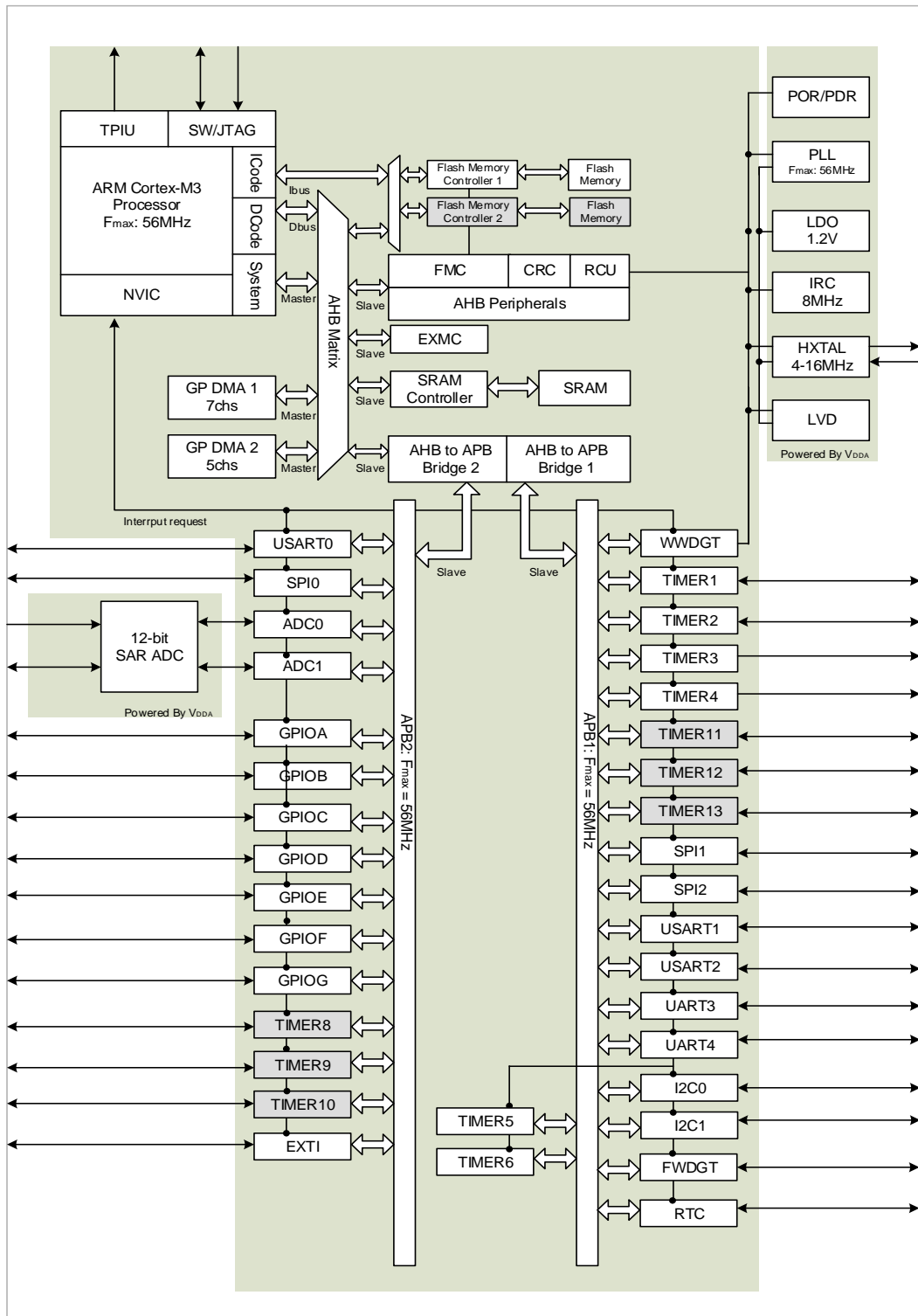

Figure 2-2. GD32F101xC/D/E/F/G/I/K block diagram



: Blocks are available in GD32F101xF/G/I/K devices

## 2.3. Pinouts and pin assignment

Figure 2-3. GD32F101Zx LQFP144 pinouts

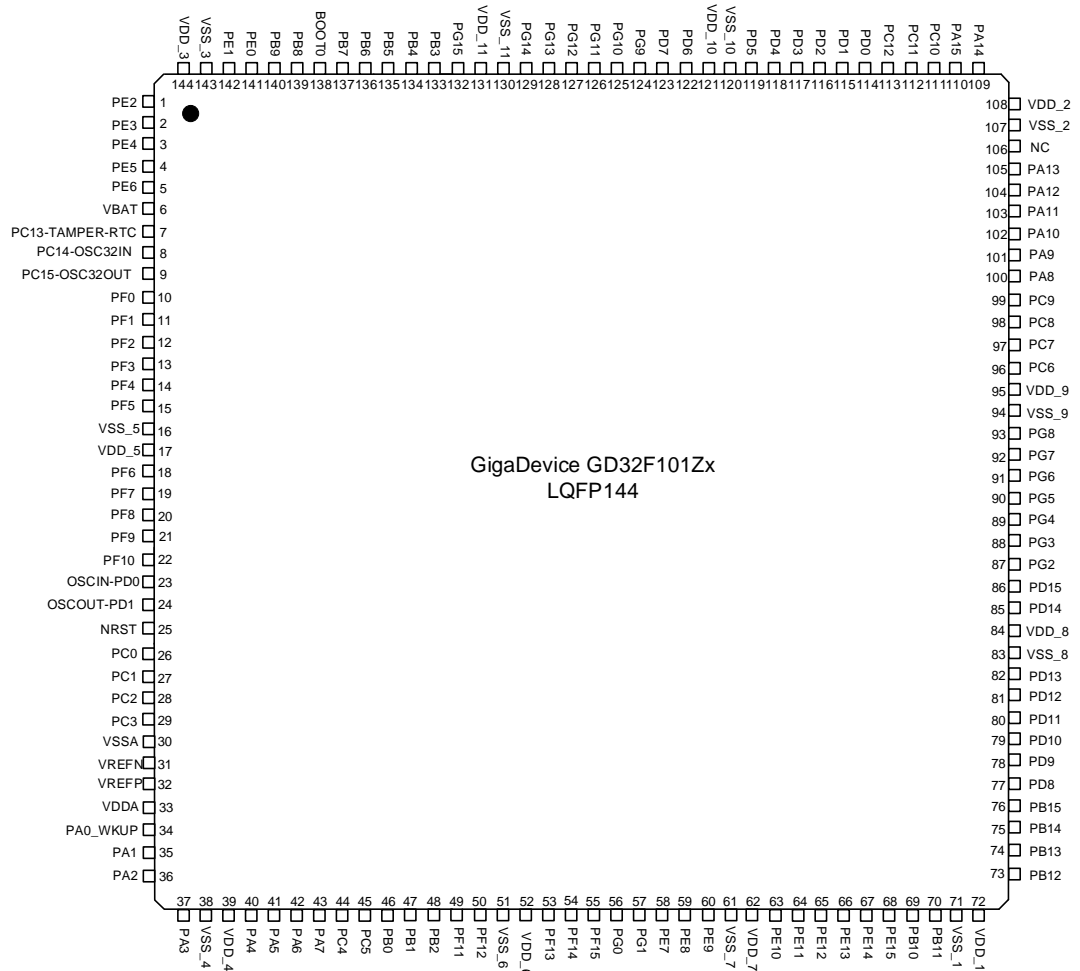

Figure 2-4. GD32F101Vx LQFP100 pinouts

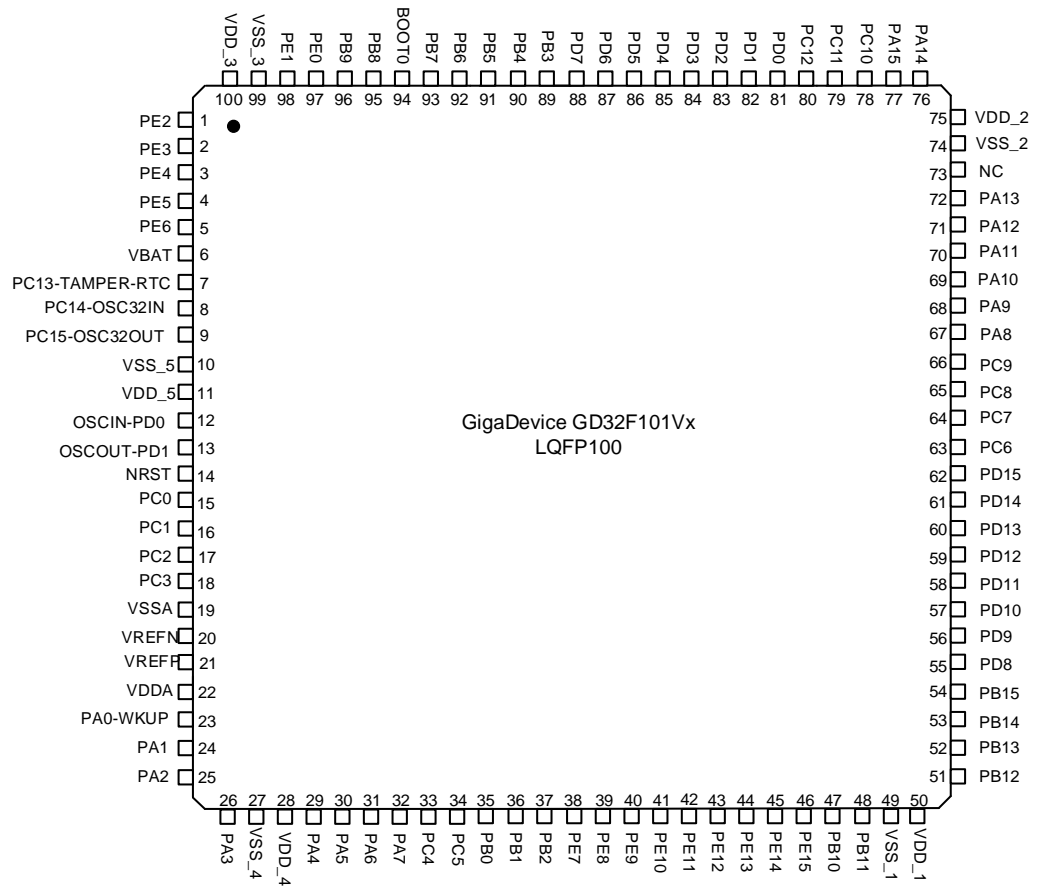

Figure 2-5. GD32F101Rx LQFP64 pinouts

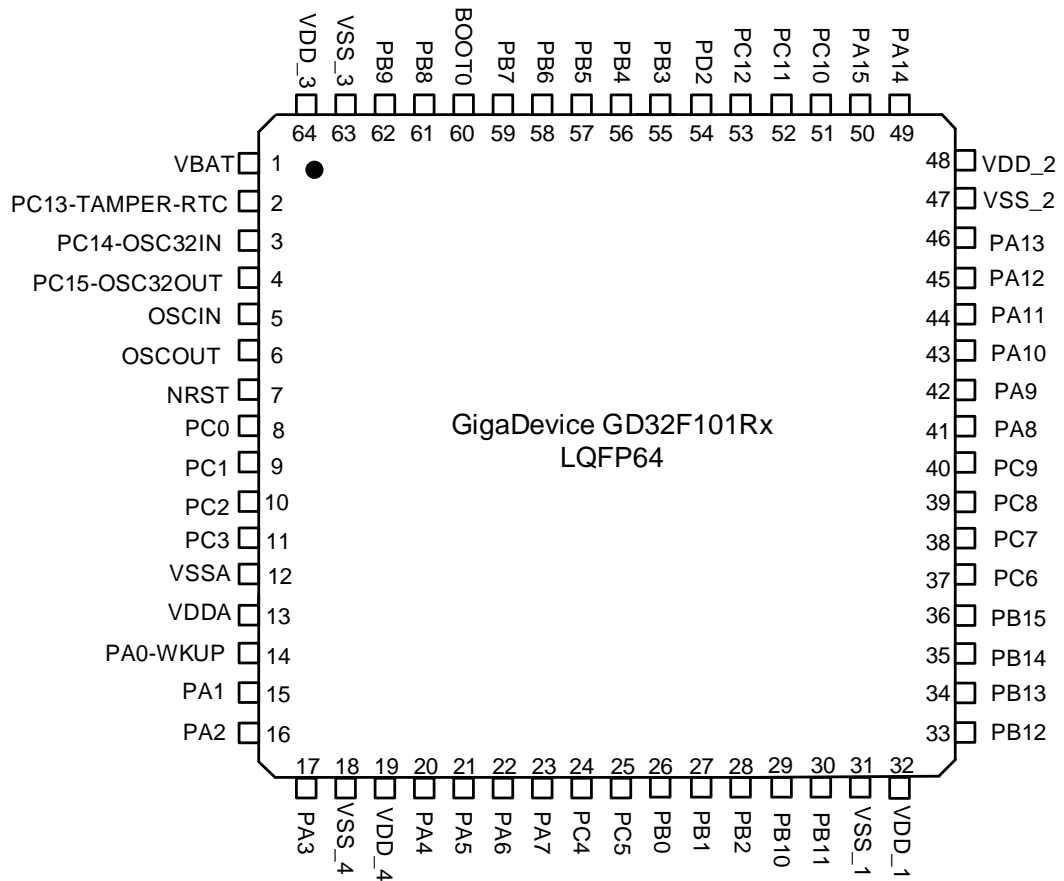



Figure 2-6. GD32F101Cx LQFP48 pinouts

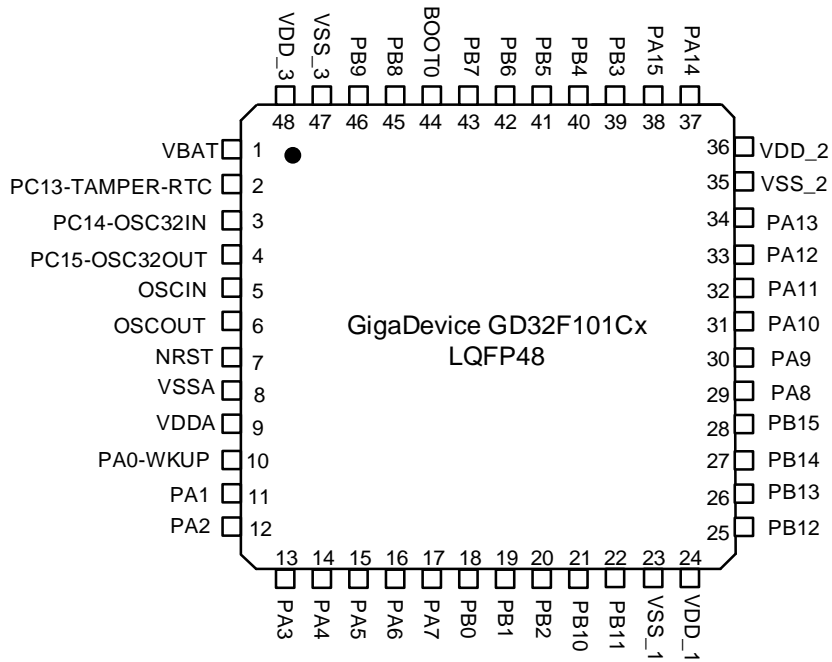
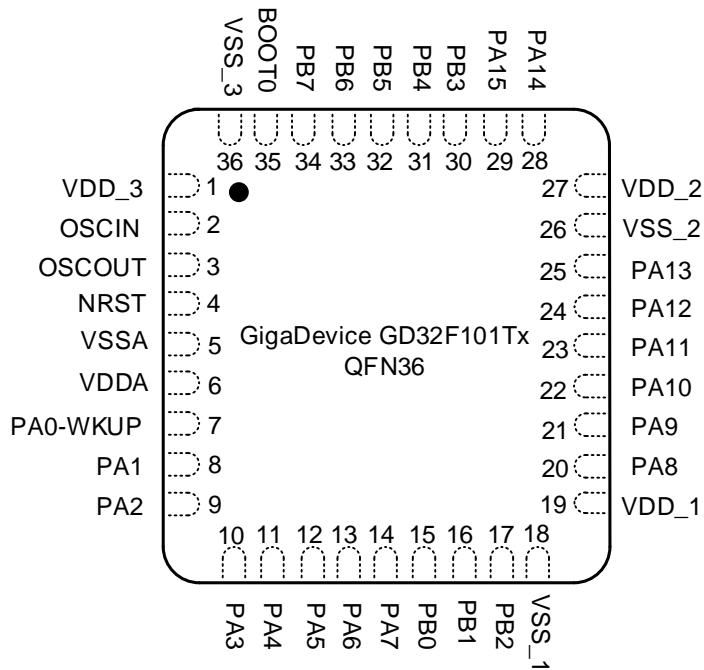

Figure 2-7. GD32F101Tx QFN36 pinouts



## 2.4. Memory map

Table 2-4. GD32F101xx memory map

Pre-defined Regions	Bus	Address	Peripherals
External device	AHB	0xA000 0000 - 0xA000 0FFF	EXMC - SWREG
External RAM		0x9000 0000 - 0x9FFF FFFF	EXMC - PC CARD
		0x7000 0000 - 0x8FFF FFFF	EXMC - NAND
		0x6000 0000 - 0x6FFF FFFF	EXMC - NOR/PSRAM/SRAM
Peripheral	AHB	0x5000 0000 - 0x5003 FFFF	Reserved
		0x4008 0000 - 0x4FFF FFFF	Reserved
		0x4004 0000 - 0x4007 FFFF	Reserved
		0x4002 BC00 - 0x4003 FFFF	Reserved
		0x4002 B000 - 0x4002 BBFF	Reserved
		0x4002 A000 - 0x4002 AFFF	Reserved
		0x4002 8000 - 0x4002 9FFF	Reserved
		0x4002 6800 - 0x4002 7FFF	Reserved
		0x4002 6400 - 0x4002 67FF	Reserved
		0x4002 6000 - 0x4002 63FF	Reserved
		0x4002 5000 - 0x4002 5FFF	Reserved
		0x4002 4000 - 0x4002 4FFF	Reserved
		0x4002 3C00 - 0x4002 3FFF	Reserved
		0x4002 3800 - 0x4002 3BFF	Reserved
		0x4002 3400 - 0x4002 37FF	Reserved
		0x4002 3000 - 0x4002 33FF	CRC
		0x4002 2C00 - 0x4002 2FFF	Reserved
		0x4002 2800 - 0x4002 2BFF	Reserved
		0x4002 2400 - 0x4002 27FF	Reserved
		0x4002 2000 - 0x4002 23FF	FMC
		0x4002 1C00 - 0x4002 1FFF	Reserved
		0x4002 1800 - 0x4002 1BFF	Reserved
		0x4002 1400 - 0x4002 17FF	Reserved
		0x4002 1000 - 0x4002 13FF	RCU
		0x4002 0C00 - 0x4002 0FFF	Reserved
		0x4002 0800 - 0x4002 0BFF	Reserved
		0x4002 0400 - 0x4002 07FF	DMA1
		0x4002 0000 - 0x4002 03FF	DMA0
0x4001 8400 - 0x4001 FFFF	Reserved		



Pre-defined Regions	Bus	Address	Peripherals	
		0x4001 8000 - 0x4001 83FF	Reserved	
	APB2	0x4001 7C00 - 0x4001 7FFF	Reserved	
		0x4001 7800 - 0x4001 7BFF	Reserved	
		0x4001 7400 - 0x4001 77FF	Reserved	
		0x4001 7000 - 0x4001 73FF	Reserved	
		0x4001 6C00 - 0x4001 6FFF	Reserved	
		0x4001 6800 - 0x4001 6BFF	Reserved	
		0x4001 5C00 - 0x4001 67FF	Reserved	
		0x4001 5800 - 0x4001 5BFF	Reserved	
		0x4001 5400 - 0x4001 57FF	TIMER10	
		0x4001 5000 - 0x4001 53FF	TIMER9	
		0x4001 4C00 - 0x4001 4FFF	TIMER8	
		0x4001 4800 - 0x4001 4BFF	Reserved	
		0x4001 4400 - 0x4001 47FF	Reserved	
		0x4001 4000 - 0x4001 43FF	Reserved	
		0x4001 3C00 - 0x4001 3FFF	Reserved	
		0x4001 3800 - 0x4001 3BFF	USART0	
		0x4001 3400 - 0x4001 37FF	Reserved	
		0x4001 3000 - 0x4001 33FF	SPI0	
		0x4001 2C00 - 0x4001 2FFF	Reserved	
		0x4001 2800 - 0x4001 2BFF	ADC1	
		0x4001 2400 - 0x4001 27FF	ADC0	
		0x4001 2000 - 0x4001 23FF	GPIOG	
		0x4001 1C00 - 0x4001 1FFF	GPIOF	
		0x4001 1800 - 0x4001 1BFF	GPIOE	
		0x4001 1400 - 0x4001 17FF	GPIOD	
		0x4001 1000 - 0x4001 13FF	GPIOC	
		0x4001 0C00 - 0x4001 0FFF	GPIOB	
		0x4001 0800 - 0x4001 0BFF	GPIOA	
		0x4001 0400 - 0x4001 07FF	EXTI	
		0x4001 0000 - 0x4001 03FF	AFIO	
		APB1	0x4000 CC00 - 0x4000 FFFF	Reserved
			0x4000 C800 - 0x4000 CBFF	Reserved
	0x4000 C400 - 0x4000 C7FF		Reserved	
	0x4000 C000 - 0x4000 C3FF		Reserved	
	0x4000 8000 - 0x4000 BFFF		Reserved	
	0x4000 7C00 - 0x4000 7FFF		Reserved	
	0x4000 7800 - 0x4000 7BFF		Reserved	
	0x4000 7400 - 0x4000 77FF		Reserved	
	0x4000 7000 - 0x4000 73FF		PMU	



Pre-defined Regions	Bus	Address	Peripherals
		0x4000 6C00 - 0x4000 6FFF	BKP
		0x4000 6800 - 0x4000 6BFF	Reserved
		0x4000 6400 - 0x4000 67FF	Reserved
		0x4000 6000 - 0x4000 63FF	Reserved
		0x4000 5C00 - 0x4000 5FFF	Reserved
		0x4000 5800 - 0x4000 5BFF	I2C1
		0x4000 5400 - 0x4000 57FF	I2C0
		0x4000 5000 - 0x4000 53FF	UART4
		0x4000 4C00 - 0x4000 4FFF	UART3
		0x4000 4800 - 0x4000 4BFF	USART2
		0x4000 4400 - 0x4000 47FF	USART1
		0x4000 4000 - 0x4000 43FF	Reserved
		0x4000 3C00 - 0x4000 3FFF	SPI2
		0x4000 3800 - 0x4000 3BFF	SPI1
		0x4000 3400 - 0x4000 37FF	Reserved
		0x4000 3000 - 0x4000 33FF	FWDGT
		0x4000 2C00 - 0x4000 2FFF	WWDGT
		0x4000 2800 - 0x4000 2BFF	RTC
		0x4000 2400 - 0x4000 27FF	Reserved
		0x4000 2000 - 0x4000 23FF	TIMER13
		0x4000 1C00 - 0x4000 1FFF	TIMER12
		0x4000 1800 - 0x4000 1BFF	TIMER11
		0x4000 1400 - 0x4000 17FF	TIMER6
		0x4000 1000 - 0x4000 13FF	TIMER5
		0x4000 0C00 - 0x4000 0FFF	TIMER4
		0x4000 0800 - 0x4000 0BFF	TIMER3
		0x4000 0400 - 0x4000 07FF	TIMER2
		0x4000 0000 - 0x4000 03FF	TIMER1
SRAM	AHB	0x2007 0000 - 0x3FFF FFFF	Reserved
		0x2006 0000 - 0x2006 FFFF	Reserved
		0x2003 0000 - 0x2005 FFFF	Reserved
		0x2002 0000 - 0x2002 FFFF	Reserved
		0x2001 C000 - 0x2001 FFFF	Reserved
		0x2001 4000 - 0x2001 BFFF	Reserved
		0x2000 5000 - 0x2001 3FFF	SRAM
		0x2000 0000 - 0x2000 4FFF	
Code	AHB	0x1FFF F810 - 0x1FFF FFFF	Reserved
		0x1FFF F800 - 0x1FFF F80F	Option Bytes
		0x1FFF B000 - 0x1FFF F7FF	Boot loader
		0x1FFF 7A10 - 0x1FFF AFFF	Reserved



Pre-defined Regions	Bus	Address	Peripherals
		0x1FFF 7800 - 0x1FFF 7A0F	Reserved
		0x1FFF 0000 - 0x1FFF 77FF	Reserved
		0x1FFE C010 - 0x1FFE FFFF	Reserved
		0x1FFE C000 - 0x1FFE C00F	Reserved
		0x1001 0000 - 0x1FFE BFFF	Reserved
		0x1000 0000 - 0x1000 FFFF	Reserved
		0x083C 0000 - 0x0FFF FFFF	Reserved
		0x0830 0000 - 0x083B FFFF	Reserved
		0x0810 0000 - 0x082F FFFF	Main Flash
		0x0802 0000 - 0x080F FFFF	
		0x0800 0000 - 0x0801 FFFF	
		0x0030 0000 - 0x07FF FFFF	Reserved
		0x0010 0000 - 0x002F FFFF	Aliased to Main Flash or Boot loader
		0x0002 0000 - 0x000F FFFF	
		0x0000 0000 - 0x0001 FFFF	

## 2.5. Clock tree

Figure 2-8. GD32F101xx clock tree

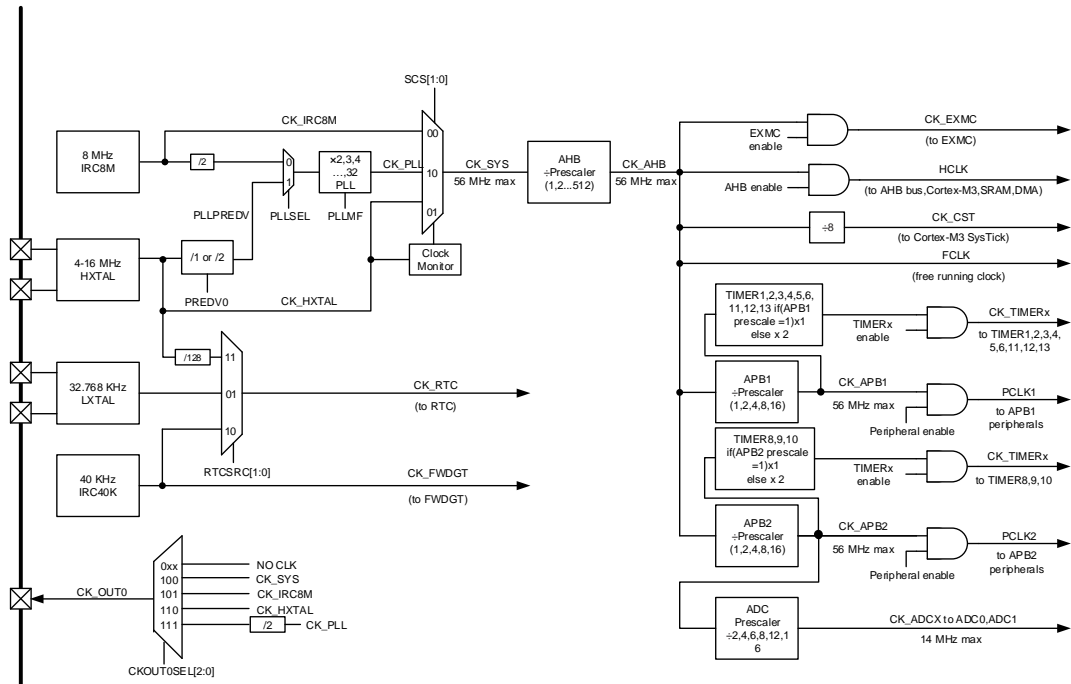

### Legend:

HXTAL: High speed external clock

LXTAL: Low speed external clock

IRC8M: High speed internal clock

IRC40K: Low speed internal clock



## 2.6. Pin definitions

### 2.6.1. GD32F101Zx LQFP144 pin definitions

Table 2-5. GD32F101Zx LQFP144 pin definitions

GD32F101Zx LQFP144				
Pin Name	Pins	Pin Type <sup>(1)</sup>	I/O Level <sup>(2)</sup>	Functions description
PE2	1	I/O	5VT	Default: PE2 Alternate: TRACECK, EXMC_A23
PE3	2	I/O	5VT	Default: PE3 Alternate: TRACED0, EXMC_A19
PE4	3	I/O	5VT	Default: PE4 Alternate: TRACED1, EXMC_A20
PE5	4	I/O	5VT	Default: PE5 Alternate: TRACED2, EXMC_A21 Remap: TIMER8_CH0 <sup>(3)</sup>
PE6	5	I/O	5VT	Default: PE6 Alternate: TRACED3, EXMC_A22 Remap: TIMER8_CH1 <sup>(3)</sup>
VBAT	6	P		Default: VBAT
PC13-TAMPER-RTC	7	I/O		Default: PC13 Alternate: TAMPER-RTC
PC14-OSC32IN	8	I/O		Default: PC14 Alternate: OSC32IN
PC15-OSC32OUT	9	I/O		Default: PC15 Alternate: OSC32OUT
PF0	10	I/O	5VT	Default: PF0 Alternate: EXMC_A0
PF1	11	I/O	5VT	Default: PF1 Alternate: EXMC_A1
PF2	12	I/O	5VT	Default: PF2 Alternate: EXMC_A2
PF3	13	I/O	5VT	Default: PF3 Alternate: EXMC_A3
PF4	14	I/O	5VT	Default: PF4 Alternate: EXMC_A4
PF5	15	I/O	5VT	Default: PF5 Alternate: EXMC_A5
VSS_5	16	P		Default: VSS_5
VDD_5	17	P		Default: VDD_5



GD32F101Zx LQFP144				
Pin Name	Pins	Pin Type <sup>(1)</sup>	I/O Level <sup>(2)</sup>	Functions description
PF6	18	I/O		Default: PF6 Alternate: EXMC_NIORD Remap: TIMER9_CH0 <sup>(3)</sup>
PF7	19	I/O		Default: PF7 Alternate: EXMC_NREG Remap: TIMER10_CH0 <sup>(3)</sup>
PF8	20	I/O		Default: PF8 Alternate: EXMC_NIOWR Remap: TIMER12_CH0 <sup>(3)</sup>
PF9	21	I/O		Default: PF9 Alternate: EXMC_CD Remap: TIMER13_CH0 <sup>(3)</sup>
PF10	22	I/O		Default: PF10 Alternate: EXMC_INTR
OSCIN-PD0	23	I		Default: OSCIN Remap: PD0
OSCOU-PD1	24	O		Default: OSCOUT Remap: PD1
NRST	25	I/O		Default: NRST
PC0	26	I/O		Default: PC0 Alternate: ADC01_IN10 <sup>(4)</sup>
PC1	27	I/O		Default: PC1 Alternate: ADC01_IN11 <sup>(4)</sup>
PC2	28	I/O		Default: PC2 Alternate: ADC01_IN12 <sup>(4)</sup>
PC3	29	I/O		Default: PC3 Alternate: ADC01_IN13 <sup>(4)</sup>
VSSA	30	P		Default: VSSA
VREFN	31	P		Default: VREFN
VREFF	32	P		Default: VREFF
VDDA	33	P		Default: VDDA
PA0-WKUP	34	I/O		Default: PA0 Alternate: WKUP, USART1_CTS, ADC01_IN0 <sup>(4)</sup> , TIMER1_CH0, TIMER1_ETI, TIMER4_CH0
PA1	35	I/O		Default: PA1 Alternate: USART1_RTS, ADC01_IN1 <sup>(4)</sup> , TIMER1_CH1, TIMER4_CH1
PA2	36	I/O		Default: PA2 Alternate: USART1_TX, ADC01_IN2 <sup>(4)</sup> , TIMER1_CH2, TIMER4_CH2, TIMER8_CH0 <sup>(3)</sup>
PA3	37	I/O		Default: PA3





GD32F101Zx LQFP144				
Pin Name	Pins	Pin Type <sup>(1)</sup>	I/O Level <sup>(2)</sup>	Functions description
				Alternate: USART1_RX, ADC01_IN3 <sup>(4)</sup> , TIMER1_CH3, TIMER4_CH3, TIMER8_CH1 <sup>(3)</sup>
VSS_4	38	P		Default: VSS_4
VDD_4	39	P		Default: VDD_4
PA4	40	I/O		Default: PA4 Alternate: SPI0_NSS, USART1_CK, ADC01_IN4 <sup>(4)</sup> Remap: SPI2_NSS
PA5	41	I/O		Default: PA5 Alternate: SPI0_SCK, ADC01_IN5 <sup>(4)</sup>
PA6	42	I/O		Default: PA6 Alternate: SPI0_MISO, ADC01_IN6 <sup>(4)</sup> , TIMER2_CH0, TIMER12_CH0 <sup>(3)</sup>
PA7	43	I/O		Default: PA7 Alternate: SPI0_MOSI, ADC01_IN7 <sup>(4)</sup> , TIMER2_CH1, TIMER13_CH0 <sup>(3)</sup>
PC4	44	I/O		Default: PC4 Alternate: ADC01_IN14 <sup>(4)</sup>
PC5	45	I/O		Default: PC5 Alternate: ADC01_IN15 <sup>(4)</sup>
PB0	46	I/O		Default: PB0 Alternate: ADC01_IN8 <sup>(4)</sup> , TIMER2_CH2
PB1	47	I/O		Default: PB1 Alternate: ADC01_IN9 <sup>(4)</sup> , TIMER2_CH3
PB2	48	I/O	5VT	Default: PB2/BOOT1
PF11	49	I/O	5VT	Default: PF11 Alternate: EXMC_NIOS16
PF12	50	I/O	5VT	Default: PF12 Alternate: EXMC_A6
VSS_6	51	P		Default: VSS_6
VDD_6	52	P		Default: VDD_6
PF13	53	I/O	5VT	Default: PF13 Alternate: EXMC_A7
PF14	54	I/O	5VT	Default: PF14 Alternate: EXMC_A8
PF15	55	I/O	5VT	Default: PF15 Alternate: EXMC_A9
PG0	56	I/O	5VT	Default: PG0 Alternate: EXMC_A10
PG1	57	I/O	5VT	Default: PG1 Alternate: EXMC_A11
PE7	58	I/O	5VT	Default: PE7



GD32F101Zx LQFP144				
Pin Name	Pins	Pin Type <sup>(1)</sup>	I/O Level <sup>(2)</sup>	Functions description
				Alternate: EXMC_D4
PE8	59	IO	5VT	Default: PE8 Alternate: EXMC_D5
PE9	60	IO	5VT	Default: PE9 Alternate: EXMC_D6
VSS_7	61	P		Default: VSS_7
VDD_7	62	P		Default: VDD_7
PE10	63	IO	5VT	Default: PE10 Alternate: EXMC_D7
PE11	64	IO	5VT	Default: PE11 Alternate: EXMC_D8
PE12	65	IO	5VT	Default: PE12 Alternate: EXMC_D9
PE13	66	IO	5VT	Default: PE13 Alternate: EXMC_D10
PE14	67	IO	5VT	Default: PE14 Alternate: EXMC_D11
PE15	68	IO	5VT	Default: PE15 Alternate: EXMC_D12
PB10	69	IO	5VT	Default: PB10 Alternate: I2C1_SCL, USART2_TX Remap: TIMER1_CH2
PB11	70	IO	5VT	Default: PB11 Alternate: I2C1_SDA, USART2_RX Remap: TIMER1_CH3
VSS_1	71	P		Default: VSS_1
VDD_1	72	P		Default: VDD_1
PB12	73	IO	5VT	Default: PB12 Alternate: SPI1_NSS, I2C1_SMBA, USART2_CK
PB13	74	IO	5VT	Default: PB13 Alternate: SPI1_SCK, USART2_CTS
PB14	75	IO	5VT	Default: PB14 Alternate: SPI1_MISO, USART2_RTS, TIMER11_CH0 <sup>(3)</sup>
PB15	76	IO	5VT	Default: PB15 Alternate: SPI1_MOSI, TIMER11_CH1 <sup>(3)</sup>
PD8	77	IO	5VT	Default: PD8 Alternate: EXMC_D13 Remap: USART2_TX
PD9	78	IO	5VT	Default: PD9 Alternate: EXMC_D14 Remap: USART2_RX



GD32F101Zx LQFP144				
Pin Name	Pins	Pin Type <sup>(1)</sup>	I/O Level <sup>(2)</sup>	Functions description
PD10	79	I/O	5VT	Default: PD10 Alternate: EXMC_D15 Remap: USART2_CK
PD11	80	I/O	5VT	Default: PD11 Alternate: EXMC_A16/EXMC_CLE Remap: USART2_CTS
PD12	81	I/O	5VT	Default: PD12 Alternate: EXMC_A17/EXMC_ALE Remap: TIMER3_CH0, USART2_RTS
PD13	82	I/O	5VT	Default: PD13 Alternate: EXMC_A18 Remap: TIMER3_CH1
VSS_8	83	P		Default: VSS_8
VDD_8	84	P		Default: VDD_8
PD14	85	I/O	5VT	Default: PD14 Alternate: EXMC_D0 Remap: TIMER3_CH2
PD15	86	I/O	5VT	Default: PD15 Alternate: EXMC_D1 Remap: TIMER3_CH3
PG2	87	I/O	5VT	Default: PG2 Alternate: EXMC_A12
PG3	88	I/O	5VT	Default: PG3 Alternate: EXMC_A13
PG4	89	I/O	5VT	Default: PG4 Alternate: EXMC_A14
PG5	90	I/O	5VT	Default: PG5 Alternate: EXMC_A15
PG6	91	I/O	5VT	Default: PG6 Alternate: EXMC_INT1
PG7	92	I/O	5VT	Default: PG7 Alternate: EXMC_INT2
PG8	93	I/O	5VT	Default: PG8
VSS_9	94	P		Default: VSS_9
VDD_9	95	P		Default: VDD_9
PC6	96	I/O	5VT	Default: PC6 Remap: TIMER2_CH0
PC7	97	I/O	5VT	Default: PC7 Remap: TIMER2_CH1
PC8	98	I/O	5VT	Default: PC8 Remap: TIMER2_CH2



GD32F101Zx LQFP144				
Pin Name	Pins	Pin Type <sup>(1)</sup>	I/O Level <sup>(2)</sup>	Functions description
PC9	99	I/O	5VT	Default: PC9 Remap: TIMER2_CH3
PA8	100	I/O	5VT	Default: PA8 Alternate: USART0_CK, CK_OUT0
PA9	101	I/O	5VT	Default: PA9 Alternate: USART0_TX
PA10	102	I/O	5VT	Default: PA10 Alternate: USART0_RX
PA11	103	I/O	5VT	Default: PA11 Alternate: USART0_CTS
PA12	104	I/O	5VT	Default: PA12 Alternate: USART0_RTS
PA13	105	I/O	5VT	Default: JTMS, SWDIO Remap: PA13
NC	106			-
VSS_2	107	P		Default: VSS_2
VDD_2	108	P		Default: VDD_2
PA14	109	I/O	5VT	Default: JTCK, SWCLK Remap: PA14
PA15	110	I/O	5VT	Default: JTDI Alternate: SPI2_NSS Remap: TIMER1_CH0, TIMER1_ETI, PA15, SPI0_NSS
PC10	111	I/O	5VT	Default: PC10 Alternate: UART3_TX Remap: USART2_TX, SPI2_SCK
PC11	112	I/O	5VT	Default: PC11 Alternate: UART3_RX Remap: USART2_RX, SPI2_MISO
PC12	113	I/O	5VT	Default: PC12 Alternate: UART4_TX Remap: USART2_CK, SPI2_MOSI
PD0	114	I/O	5VT	Default: PD0 Alternate: EXMC_D2
PD1	115	I/O	5VT	Default: PD1 Alternate: EXMC_D3
PD2	116	I/O	5VT	Default: PD2 Alternate: TIMER2_ETI, UART4_RX
PD3	117	I/O	5VT	Default: PD3 Alternate: EXMC_CLK Remap: USART1_CTS
PD4	118	I/O	5VT	Default: PD4



GD32F101Zx LQFP144				
Pin Name	Pins	Pin Type <sup>(1)</sup>	I/O Level <sup>(2)</sup>	Functions description
				Alternate: EXMC_NOE Remap: USART1_RTS
PD5	119	IO	5VT	Default: PD5 Alternate: EXMC_NWE Remap: USART1_TX
VSS_10	120			Default: VSS_10
VDD_10	121			Default: VDD_10
PD6	122	IO	5VT	Default: PD6 Alternate: EXMC_NWAIT Remap: USART1_RX
PD7	123	IO	5VT	Default: PD7 Alternate: EXMC_NE0, EXMC_NCE1 Remap: USART1_CK
PG9	124	IO	5VT	Default: PG9 Alternate: EXMC_NE1, EXMC_NCE2
PG10	125	IO	5VT	Default: PG10 Alternate: EXMC_NCE3_0, EXMC_NE2
PG11	126	IO	5VT	Default: PG11 Alternate: EXMC_NCE3_1
PG12	127	IO	5VT	Default: PG12 Alternate: EXMC_NE3
PG13	128	IO	5VT	Default: PG13 Alternate: EXMC_A24
PG14	129	IO	5VT	Default: PG14 Alternate: EXMC_A25
VSS_11	130	P		Default: VSS_11
VDD_11	131	P		Default: VDD_11
PG15	132	IO	5VT	Default: PG15
PB3	133	IO	5VT	Default: JTDO Alternate: SPI2_SCK Remap: PB3, TRACESWO, TIMER1_CH1, SPI0_SCK
PB4	134	IO	5VT	Default: NJTRST Alternate: SPI2_MISO Remap: TIMER2_CH0, PB4, SPI0_MISO
PB5	135	IO		Default: PB5 Alternate: I2C0_SMBA, SPI2_MOS1 Remap: TIMER2_CH1, SPI0_MOS1
PB6	136	IO	5VT	Default: PB6 Alternate: I2C0_SCL, TIMER3_CH0 Remap: USART0_TX
PB7	137	IO	5VT	Default: PB7



GD32F101Zx LQFP144				
Pin Name	Pins	Pin Type <sup>(1)</sup>	I/O Level <sup>(2)</sup>	Functions description
				Alternate: I2C0_SDA , TIMER3_CH1, EXMC_NADV Remap: USART0_RX
BOOT0	138	I		Default: BOOT0
PB8	139	IO	5VT	Default: PB8 Alternate: TIMER3_CH2, TIMER9_CH0 <sup>(3)</sup> Remap: I2C0_SCL
PB9	140	IO	5VT	Default: PB9 Alternate: TIMER3_CH3, TIMER10_CH0 <sup>(3)</sup> Remap: I2C0_SDA
PE0	141	IO	5VT	Default: PE0 Alternate: TIMER3_ETI, EXMC_NBL0
PE1	142	IO	5VT	Default: PE1 Alternate: EXMC_NBL1
VSS_3	143	P		Default: VSS_3
VDD_3	144	P		Default: VDD_3

**Notes:**

(1) Type: I = input, O = output, P = power.

(2) I/O Level: 5VT = 5 V tolerant.

(3) Functions are available in GD32F101ZF/G//K devices.

(4) In GD32F101ZF/G//K devices, functions are fully available for ADC0 and ADC1; In GD32F101ZC/D/E devices, functions are available for ADC0.



## 2.6.2. GD32F101Vx LQFP100 pin definitions

Table 2-6. GD32F101Vx LQFP100 pin definitions

GD32F101Vx LQFP100				
Pin Name	Pins	Pin Type <sup>(1)</sup>	I/O Level <sup>(2)</sup>	Functions description
PE2	1	I/O	5VT	Default: PE2 Alternate: TRACECK <sup>(3)</sup> , EXMC_A23
PE3	2	I/O	5VT	Default: PE3 Alternate: TRACED0 <sup>(3)</sup> , EXMC_A19
PE4	3	I/O	5VT	Default: PE4 Alternate: TRACED1 <sup>(3)</sup> , EXMC_A20
PE5	4	I/O	5VT	Default: PE5 Alternate: TRACED2 <sup>(3)</sup> , EXMC_A21 Remap: TIMER8_CH0 <sup>(4)</sup>
PE6	5	I/O	5VT	Default: PE6 Alternate: TRACED3 <sup>(3)</sup> , EXMC_A22 Remap: TIMER8_CH1 <sup>(4)</sup>
VBAT	6	P		Default: VBAT
PC13- TAMPER- RTC	7	I/O		Default: PC13 Alternate: TAMPER-RTC
PC14- OSC32IN	8	I/O		Default: PC14 Alternate: OSC32IN
PC15- OSC32OUT	9	I/O		Default: PC15 Alternate: OSC32OUT
VSS_5	10	P		Default: VSS_5
VDD_5	11	P		Default: VDD_5
OSCIN-PD0	12	I		Default: OSCIN Remap: PD0
OSCOUT- PD1	13	O		Default: OSCOUT Remap: PD1
NRST	14	I/O		Default: NRST
PC0	15	I/O		Default: PC0 Alternate: ADC01_IN10 <sup>(5)</sup>
PC1	16	I/O		Default: PC1 Alternate: ADC01_IN11 <sup>(5)</sup>
PC2	17	I/O		Default: PC2 Alternate: ADC01_IN12 <sup>(5)</sup>
PC3	18	I/O		Default: PC3 Alternate: ADC01_IN13 <sup>(5)</sup>



GD32F101Vx LQFP100				
Pin Name	Pins	Pin Type <sup>(1)</sup>	I/O Level <sup>(2)</sup>	Functions description
VSSA	19	P		Default: VSSA
VREFN	20	P		Default: VREFN
VREFP	21	P		Default: VREFP
VDDA	22	P		Default: VDDA
PA0-WKUP	23	I/O		Default: PA0 Alternate: WKUP, USART1_CTS, ADC01_IN0 <sup>(5)</sup> , TIMER1_CH0, TIMER1_ET1, TIMER4_CH0 <sup>(3)</sup>
PA1	24	I/O		Default: PA1 Alternate: USART1_RTS, ADC01_IN1 <sup>(5)</sup> , TIMER1_CH1, TIMER4_CH1 <sup>(3)</sup>
PA2	25	I/O		Default: PA2 Alternate: USART1_TX, ADC01_IN2 <sup>(5)</sup> , TIMER1_CH2, TIMER4_CH2 <sup>(3)</sup> , TIMER8_CH0 <sup>(4)</sup>
PA3	26	I/O		Default: PA3 Alternate: USART1_RX, ADC01_IN3 <sup>(5)</sup> , TIMER1_CH3, TIMER4_CH3 <sup>(3)</sup> , TIMER8_CH1 <sup>(4)</sup>
VSS_4	27	P		Default: VSS_4
VDD_4	28	P		Default: VDD_4
PA4	29	I/O		Default: PA4 Alternate: SPI0_NSS, USART1_CK, ADC01_IN4 <sup>(5)</sup> Remap: SPI2_NSS <sup>(3)</sup>
PA5	30	I/O		Default: PA5 Alternate: SPI0_SCK, ADC01_IN5 <sup>(5)</sup>
PA6	31	I/O		Default: PA6 Alternate: SPI0_MISO, ADC01_IN6 <sup>(5)</sup> , TIMER2_CH0, TIMER12_CH0 <sup>(4)</sup>
PA7	32	I/O		Default: PA7 Alternate: SPI0_MOSI, ADC01_IN7 <sup>(5)</sup> , TIMER2_CH1, TIMER13_CH0 <sup>(4)</sup>
PC4	33	I/O		Default: PC4 Alternate: ADC01_IN14 <sup>(5)</sup>
PC5	34	I/O		Default: PC5 Alternate: ADC01_IN15 <sup>(5)</sup>
PB0	35	I/O		Default: PB0 Alternate: ADC01_IN8 <sup>(5)</sup> , TIMER2_CH2
PB1	36	I/O		Default: PB1 Alternate: ADC01_IN9 <sup>(5)</sup> , TIMER2_CH3
PB2	37	I/O	5VT	Default: PB2/BOOT1
PE7	38	I/O	5VT	Default: PE7 Alternate: EXMC_D4





GD32F101Vx LQFP100				
Pin Name	Pins	Pin Type <sup>(1)</sup>	I/O Level <sup>(2)</sup>	Functions description
PE8	39	IO	5VT	Default: PE8 Alternate: EXMC_D5
PE9	40	IO	5VT	Default: PE9 Alternate: EXMC_D6
PE10	41	IO	5VT	Default: PE10 Alternate: EXMC_D7
PE11	42	IO	5VT	Default: PE11 Alternate: EXMC_D8
PE12	43	IO	5VT	Default: PE12 Alternate: EXMC_D9
PE13	44	IO	5VT	Default: PE13 Alternate: EXMC_D10
PE14	45	IO	5VT	Default: PE14 Alternate: EXMC_D11
PE15	46	IO	5VT	Default: PE15 Alternate: EXMC_D12
PB10	47	IO	5VT	Default: PB10 Alternate: I2C1_SCL, USART2_TX Remap: TIMER1_CH2
PB11	48	IO	5VT	Default: PB11 Alternate: I2C1_SDA, USART2_RX Remap: TIMER1_CH3
VSS_1	49	P		Default: VSS_1
VDD_1	50	P		Default: VDD_1
PB12	51	IO	5VT	Default: PB12 Alternate: SPI1_NSS, I2C1_SMBA, USART2_CK
PB13	52	IO	5VT	Default: PB13 Alternate: SPI1_SCK, USART2_CTS
PB14	53	IO	5VT	Default: PB14 Alternate: SPI1_MISO, USART2_RTS, TIMER11_CH0 <sup>(4)</sup>
PB15	54	IO	5VT	Default: PB15 Alternate: SPI1_MOSI, TIMER11_CH1 <sup>(4)</sup>
PD8	55	IO	5VT	Default: PD8 Alternate: EXMC_D13 Remap: USART2_TX
PD9	56	IO	5VT	Default: PD9 Alternate: EXMC_D14 Remap: USART2_RX
PD10	57	IO	5VT	Default: PD10 Alternate: EXMC_D15



GD32F101Vx LQFP100				
Pin Name	Pins	Pin Type <sup>(1)</sup>	I/O Level <sup>(2)</sup>	Functions description
				Remap: USART2_CK
PD11	58	I/O	5VT	Default: PD11 Alternate: EXMC_A16/EXMC_CLE Remap: USART2_CTS
PD12	59	I/O	5VT	Default: PD12 Alternate: EXMC_A17/EXMC_ALE Remap: TIMER3_CH0, USART2_RTS
PD13	60	I/O	5VT	Default: PD13 Alternate: EXMC_A18 Remap: TIMER3_CH1
PD14	61	I/O	5VT	Default: PD14 Alternate: EXMC_D0 Remap: TIMER3_CH2
PD15	62	I/O	5VT	Default: PD15 Alternate: EXMC_D1 Remap: TIMER3_CH3
PC6	63	I/O	5VT	Default: PC6 Remap: TIMER2_CH0
PC7	64	I/O	5VT	Default: PC7 Remap: TIMER2_CH1
PC8	65	I/O	5VT	Default: PC8 Remap: TIMER2_CH2
PC9	66	I/O	5VT	Default: PC9 Remap: TIMER2_CH3
PA8	67	I/O	5VT	Default: PA8 Alternate: USART0_CK, CK_OUT0
PA9	68	I/O	5VT	Default: PA9 Alternate: USART0_TX
PA10	69	I/O	5VT	Default: PA10 Alternate: USART0_RX
PA11	70	I/O	5VT	Default: PA11 Alternate: USART0_CTS
PA12	71	I/O	5VT	Default: PA12 Alternate: USART0_RTS
PA13	72	I/O	5VT	Default: JTMS, SWDIO Remap: PA13
NC	73			-
VSS_2	74	P		Default: VSS_2
VDD_2	75	P		Default: VDD_2
PA14	76	I/O	5VT	Default: JTCK, SWCLK



GD32F101Vx LQFP100				
Pin Name	Pins	Pin Type <sup>(1)</sup>	I/O Level <sup>(2)</sup>	Functions description
				Remap: PA14
PA15	77	I/O	5VT	Default: JTDI Alternate: SPI2_NSS <sup>(3)</sup> Remap: TIMER1_CH0, TIMER1_ETI, PA15, SPI0_NSS
PC10	78	I/O	5VT	Default: PC10 Alternate: UART3_TX <sup>(3)</sup> Remap: USART2_TX, SPI2_SCK <sup>(3)</sup>
PC11	79	I/O	5VT	Default: PC11 Alternate: UART3_RX <sup>(3)</sup> , SPI2_MISO <sup>(3)</sup> Remap: USART2_RX
PC12	80	I/O	5VT	Default: PC12 Alternate: UART4_TX <sup>(3)</sup> Remap: USART2_CK, SPI2_MOSI <sup>(3)</sup>
PD0	81	I/O	5VT	Default: PD0 Alternate: EXMC_D2
PD1	82	I/O	5VT	Default: PD1 Alternate: EXMC_D3
PD2	83	I/O	5VT	Default: PD2 Alternate: TIMER2_ETI, UART4_RX <sup>(3)</sup>
PD3	84	I/O	5VT	Default: PD3 Alternate: EXMC_CLK Remap: USART1_CTS
PD4	85	I/O	5VT	Default: PD4 Alternate: EXMC_NOE Remap: USART1_RTS
PD5	86	I/O	5VT	Default: PD5 Alternate: EXMC_NWE Remap: USART1_TX
PD6	87	I/O	5VT	Default: PD6 Alternate: EXMC_NWAIT Remap: USART1_RX
PD7	88	I/O	5VT	Default: PD7 Alternate: EXMC_NE0/EXMC_NCE1 Remap: USART1_CK
PB3	89	I/O	5VT	Default: JTDO Alternate: SPI2_SCK <sup>(3)</sup> Remap: PB3, TRACESWO <sup>(3)</sup> , TIMER1_CH1, SPI0_SCK
PB4	90	I/O	5VT	Default: NJTRST Alternate: SPI2_MISO <sup>(3)</sup> Remap: TIMER2_CH0, PB4, SPI0_MISO



GD32F101Vx LQFP100				
Pin Name	Pins	Pin Type <sup>(1)</sup>	I/O Level <sup>(2)</sup>	Functions description
PB5	91	I/O		Default: PB5 Alternate: I2C0_SMBA, SPI2_MOSI <sup>(3)</sup> Remap: TIMER2_CH1, SPI0_MOSI
PB6	92	I/O	5VT	Default: PB6 Alternate: I2C0_SCL, TIMER3_CH0, Remap: USART0_TX
PB7	93	I/O	5VT	Default: PB7 Alternate: I2C0_SDA, TIMER3_CH1, EXMC_NADV Remap: USART0_RX
BOOT0	94	I		Default: BOOT0
PB8	95	I/O	5VT	Default: PB8 Alternate: TIMER3_CH2, TIMER9_CH0 <sup>(4)</sup> Remap: I2C0_SCL
PB9	96	I/O	5VT	Default: PB9 Alternate: TIMER3_CH3, TIMER10_CH0 <sup>(4)</sup> Remap: I2C0_SDA
PE0	97	I/O	5VT	Default: PE0 Alternate: TIMER3_ETI, EXMC_NBL0
PE1	98	I/O	5VT	Default: PE1 Alternate: EXMC_NBL1
VSS_3	99	P		Default: VSS_3
VDD_3	100	P		Default: VDD_3

**Notes:**

(1) Type: I = input, O = output, P = power.

(2) I/O Level: 5VT = 5 V tolerant.

(3) Functions are available in GD32F101VC/D/E/F/G/I/K devices.

(4) Functions are available in GD32F101VF/G/I/K devices.

(5) In GD32F101VF/G/I/K devices, functions are fully available for ADC0 and ADC1; In GD32F101V8/B/C/D/E devices, functions are available for ADC0.

2.6.3. GD32F101Rx LQFP64 pin definitions

Table 2-7. GD32F101Rx LQFP64 pin definitions

GD32F101Rx LQFP64				
Pin Name	Pins	Pin Type <sup>(1)</sup>	I/O Level <sup>(2)</sup>	Functions description
VBAT	1	P		Default: VBAT
PC13-TAMPER-RTC	2	I/O		Default: PC13 Alternate: TAMPER-RTC
PC14-OSC32IN	3	I/O		Default: PC14 Alternate: OSC32IN
PC15-OSC32OUT	4	I/O		Default: PC15 Alternate: OSC32OUT
OSCIN	5	I		Default: OSCIN
OSCOUT	6	O		Default: OSCOUT
NRST	7	I/O		Default: NRST
PC0	8	I/O		Default: PC0 Alternate: ADC01_IN10 <sup>(5)</sup>
PC1	9	I/O		Default: PC1 Alternate: ADC01_IN11 <sup>(5)</sup>
PC2	10	I/O		Default: PC2 Alternate: ADC01_IN12 <sup>(5)</sup>
PC3	11	I/O		Default: PC3 Alternate: ADC01_IN13 <sup>(5)</sup>
VSSA	12	P		Default: VSSA
VDDA	13	P		Default: VDDA
PA0-WKUP	14	I/O		Default: PA0 Alternate: WKUP, USART1_CTS, ADC01_IN0 <sup>(5)</sup> , TIMER1_CH0, TIMER1_ETI, TIMER4_CH0 <sup>(3)</sup>
PA1	15	I/O		Default: PA1 Alternate: USART1_RTS, ADC01_IN1 <sup>(5)</sup> , TIMER1_CH1, TIMER4_CH1 <sup>(3)</sup>
PA2	16	I/O		Default: PA2 Alternate: USART1_TX, ADC01_IN2 <sup>(5)</sup> , TIMER1_CH2, TIMER4_CH2 <sup>(3)</sup> , TIMER8_CH0 <sup>(4)</sup>
PA3	17	I/O		Default: PA3 Alternate: USART1_RX, ADC01_IN3 <sup>(5)</sup> , TIMER1_CH3, TIMER4_CH3 <sup>(3)</sup> , TIMER8_CH1 <sup>(4)</sup>
VSS_4	18	P		Default: VSS_4
VDD_4	19	P		Default: VDD_4
PA4	20	I/O		Default: PA4



GD32F101Rx LQFP64				
Pin Name	Pins	Pin Type <sup>(1)</sup>	I/O Level <sup>(2)</sup>	Functions description
				Alternate: SPI0_NSS, USART1_CK, ADC01_IN4 <sup>(5)</sup> Remap: SPI2_NSS <sup>(3)</sup>
PA5	21	IO		Default: PA5 Alternate: SPI0_SCK, ADC01_IN5 <sup>(5)</sup>
PA6	22	IO		Default: PA6 Alternate: SPI0_MISO, ADC01_IN6 <sup>(5)</sup> , TIMER2_CH0, TIMER12_CH0 <sup>(4)</sup>
PA7	23	IO		Default: PA7 Alternate: SPI0_MOSI, ADC01_IN7 <sup>(5)</sup> , TIMER2_CH1, TIMER13_CH0 <sup>(4)</sup>
PC4	24	IO		Default: PC4 Alternate: ADC01_IN14 <sup>(5)</sup>
PC5	25	IO		Default: PC5 Alternate: ADC01_IN15 <sup>(5)</sup>
PB0	26	IO		Default: PB0 Alternate: ADC01_IN8 <sup>(5)</sup> , TIMER2_CH2
PB1	27	IO		Default: PB1 Alternate: ADC01_IN9 <sup>(5)</sup> , TIMER2_CH3
PB2	28	IO	5VT	Default: PB2/BOOT1
PB10	29	IO	5VT	Default: PB10 Alternate: I2C1_SCL <sup>(6)</sup> , USART2_TX <sup>(6)</sup> Remap: TIMER1_CH2
PB11	30	IO	5VT	Default: PB11 Alternate: I2C1_SDA <sup>(6)</sup> , USART2_RX <sup>(6)</sup> Remap: TIMER1_CH3
VSS_1	31	P		Default: VSS_1
VDD_1	32	P		Default: VDD_1
PB12	33	IO	5VT	Default: PB12 Alternate: SPI1_NSS <sup>(6)</sup> , I2C1_SMBA <sup>(6)</sup> , USART2_CK <sup>(6)</sup>
PB13	34	IO	5VT	Default: PB13 Alternate: SPI1_SCK <sup>(6)</sup> , USART2_CTS <sup>(6)</sup>
PB14	35	IO	5VT	Default: PB14 Alternate: SPI1_MISO <sup>(6)</sup> , USART2_RTS <sup>(6)</sup> , TIMER11_CH0 <sup>(4)</sup>
PB15	36	IO	5VT	Default: PB15 Alternate: SPI1_MOSI <sup>(6)</sup> , TIMER11_CH1 <sup>(4)</sup>
PC6	37	IO	5VT	Default: PC6 Remap: TIMER2_CH0
PC7	38	IO	5VT	Default: PC7 Remap: TIMER2_CH1
PC8	39	IO	5VT	Default: PC8



GD32F101Rx LQFP64				
Pin Name	Pins	Pin Type <sup>(1)</sup>	I/O Level <sup>(2)</sup>	Functions description
				Remap: TIMER2_CH2
PC9	40	IO	5VT	Default: PC9 Remap: TIMER2_CH3
PA8	41	IO	5VT	Default: PA8 Alternate: USART0_CK, CK_OUT0
PA9	42	IO	5VT	Default: PA9 Alternate: USART0_TX
PA10	43	IO	5VT	Default: PA10 Alternate: USART0_RX
PA11	44	IO	5VT	Default: PA11 Alternate: USART0_CTS
PA12	45	IO	5VT	Default: PA12 Alternate: USART0_RTS
PA13	46	IO	5VT	Default: JTMS, SWDIO Remap: PA13
NC	-			-
VSS_2	47	P		Default: VSS_2
VDD_2	48	P		Default: VDD_2
PA14	49	IO	5VT	Default: JTCK, SWCLK Remap: PA14
PA15	50	IO	5VT	Default: JTDI Alternate: SPI2_NSS <sup>(3)</sup> Remap: TIMER1_CH0, TIMER1_ETI, PA15, SPI0_NSS
PC10	51	IO	5VT	Default: PC10 Alternate: UART3_TX <sup>(3)</sup> Remap: USART2_TX <sup>(6)</sup> , SPI2_SCK <sup>(3)</sup>
PC11	52	IO	5VT	Default: PC11 Alternate: UART3_RX <sup>(3)</sup> Remap: USART2_RX <sup>(6)</sup> , SPI2_MISO <sup>(3)</sup>
PC12	53	IO	5VT	Default: PC12 Alternate: UART4_TX <sup>(3)</sup> Remap: USART2_CK <sup>(6)</sup> , SPI2_MOSI <sup>(3)</sup>
PD2	54	IO	5VT	Default: PD2 Alternate: TIMER2_ETI, UART4_RX <sup>(3)</sup>
PB3	55	IO	5VT	Default: JTDO Alternate: SPI2_SCK <sup>(3)</sup> Remap: PB3, TRACESWO <sup>(3)</sup> , TIMER1_CH1, SPI0_SCK
PB4	56	IO	5VT	Default: NJTRST Alternate: SPI2_MISO <sup>(3)</sup> Remap: TIMER2_CH0, PB4, SPI0_MISO
PB5	57	IO		Default: PB5



GD32F101Rx LQFP64				
Pin Name	Pins	Pin Type <sup>(1)</sup>	I/O Level <sup>(2)</sup>	Functions description
				Alternate: I2C0_SMBA, SPI2_MOSI <sup>(3)</sup> Remap: TIMER2_CH1, SPI0_MOSI
PB6	58	I/O	5VT	Default: PB6 Alternate: I2C0_SCL, TIMER3_CH0 <sup>(6)</sup> , Remap: USART0_TX
PB7	59	I/O	5VT	Default: PB7 Alternate: I2C0_SDA, TIMER3_CH1 <sup>(6)</sup> Remap: USART0_RX
BOOT0	60	I		Default: BOOT0
PB8	61	I/O	5VT	Default: PB8 Alternate: TIMER3_CH2 <sup>(6)</sup> , TIMER9_CH0 <sup>(4)</sup> Remap: I2C0_SCL
PB9	62	I/O	5VT	Default: PB9 Alternate: TIMER3_CH3 <sup>(6)</sup> , TIMER10_CH0 <sup>(4)</sup> Remap: I2C0_SDA
VSS_3	63	P		Default: VSS_3
VDD_3	64	P		Default: VDD_3

**Notes:**

(1) Type: I = input, O = output, P = power.

(2) I/O Level: 5VT = 5 V tolerant.

(3) Functions are available in GD32F101RC/D/E/F/G/I/K devices.

(4) Functions are available in GD32F101RF/G/I/K devices.

(5) In GD32F101RF/G/I/K devices, functions are fully available for ADC0 and ADC1; In GD32F101R4/6/8/B/C/D/E devices, functions are available for ADC0.

(6) Functions are available in GD32F101R8/B/C/D/E/F/G/I/K devices.



2.6.4. GD32F101Cx LQFP48 pin definitions

Table 2-8. GD32F101Cx LQFP48 pin definitions

GD32F101Cx LQFP48				
Pin Name	Pins	Pin Type <sup>(1)</sup>	I/O Level <sup>(2)</sup>	Functions description
VBAT	1	P		Default: VBAT
PC13-TAMPER-RTC	2	IO		Default: PC13 Alternate: TAMPER-RTC
PC14-OSC32IN	3	IO		Default: PC14 Alternate: OSC32IN
PC15-OSC32OUT	4	IO		Default: PC15 Alternate: OSC32OUT
OSCIN	5	I		Default: OSCIN
OSCOUT	6	O		Default: OSCOUT
NRST	7	IO		Default: NRST
VSSA	8	P		Default: VSSA
VDDA	9	P		Default: VDDA
PA0-WKUP	10	IO		Default: PA0 Alternate: WKUP, USART1_CTS, ADC0_IN0, TIMER1_CH0, TIMER1_ETI
PA1	11	IO		Default: PA1 Alternate: USART1_RTS, ADC0_IN1, TIMER1_CH1
PA2	12	IO		Default: PA2 Alternate: USART1_TX, ADC0_IN2, TIMER1_CH2
PA3	13	IO		Default: PA3 Alternate: USART1_RX, ADC0_IN3, TIMER1_CH3
PA4	14	IO		Default: PA4 Alternate: SPI0_NSS, USART1_CK, ADC0_IN4
PA5	15	IO		Default: PA5 Alternate: SPI0_SCK, ADC0_IN5
PA6	16	IO		Default: PA6 Alternate: SPI0_MISO, ADC0_IN6, TIMER2_CH0
PA7	17	IO		Default: PA7 Alternate: SPI0_MOSI, ADC0_IN7, TIMER2_CH1
PB0	18	IO		Default: PB0 Alternate: ADC0_IN8, TIMER2_CH2
PB1	19	IO		Default: PB1 Alternate: ADC0_IN9, TIMER2_CH3
PB2	20	IO	5VT	Default: PB2/BOOT1
PB10	21	IO	5VT	Default: PB10



GD32F101Cx LQFP48				
Pin Name	Pins	Pin Type <sup>(1)</sup>	I/O Level <sup>(2)</sup>	Functions description
				Alternate: I2C1_SCL <sup>(3)</sup> , USART2_TX <sup>(3)</sup> Remap: TIMER1_CH2
PB11	22	IO	5VT	Default: PB11 Alternate: I2C1_SDA <sup>(3)</sup> , USART2_RX <sup>(3)</sup> Remap: TIMER1_CH3
VSS_1	23	P		Default: VSS_1
VDD_1	24	P		Default: VDD_1
PB12	25	IO	5VT	Default: PB12 Alternate: SPI1_NSS <sup>(3)</sup> , I2C1_SMBA <sup>(3)</sup> , USART2_CK <sup>(3)</sup>
PB13	26	IO	5VT	Default: PB13 Alternate: SPI1_SCK <sup>(3)</sup> , USART2_CTS <sup>(3)</sup>
PB14	27	IO	5VT	Default: PB14 Alternate: SPI1_MISO <sup>(3)</sup> , USART2_RTS <sup>(3)</sup>
PB15	28	IO	5VT	Default: PB15 Alternate: SPI1_MOSI <sup>(3)</sup>
PA8	29	IO	5VT	Default: PA8 Alternate: USART0_CK, CK_OUT0
PA9	30	IO	5VT	Default: PA9 Alternate: USART0_TX
PA10	31	IO	5VT	Default: PA10 Alternate: USART0_RX
PA11	32	IO	5VT	Default: PA11 Alternate: USART0_CTS
PA12	33	IO	5VT	Default: PA12 Alternate: USART0_RTS
PA13	34	IO	5VT	Default: JTMS, SWDIO Remap: PA13
VSS_2	35	P		Default: VSS_2
VDD_2	36	P		Default: VDD_2
PA14	37	IO	5VT	Default: JTCK, SWCLK Remap: PA14
PA15	38	IO	5VT	Default: JTDI Remap: TIMER1_CH0, TIMER1_ETI, PA15, SPI0_NSS
PB3	39	IO	5VT	Default: JTDO Remap: PB3, TIMER1_CH1, SPI0_SCK
PB4	40	IO	5VT	Default: NJTRST Remap: TIMER2_CH0, PB4, SPI0_MISO
PB5	41	IO		Default: PB5 Alternate: I2C0_SMBA Remap: TIMER2_CH1, SPI0_MOSI
PB6	42	IO	5VT	Default: PB6



GD32F101Cx LQFP48				
Pin Name	Pins	Pin Type <sup>(1)</sup>	I/O Level <sup>(2)</sup>	Functions description
				Alternate: I2C0_SCL, TIMER3_CH0 <sup>(3)</sup> , Remap: USART0_TX
PB7	43	IO	5VT	Default: PB7 Alternate: I2C0_SDA, TIMER3_CH1 <sup>(3)</sup> Remap: USART0_RX
BOOT0	44	I		Default: BOOT0
PB8	45	IO	5VT	Default: PB8 Alternate: TIMER3_CH2 <sup>(3)</sup> Remap: I2C0_SCL
PB9	46	IO	5VT	Default: PB9 Alternate: TIMER3_CH3 <sup>(3)</sup> Remap: I2C0_SDA
VSS_3	47	P		Default: VSS_3
VDD_3	48	P		Default: VDD_3

**Notes:**

(1) Type: I = input, O = output, P = power.

(2) I/O Level: 5VT = 5 V tolerant.

(3) Functions are available in GD32F101C8/B devices.



## 2.6.5. GD32F101Tx QFN36 pin definitions

Table 2-9. GD32F101Tx QFN36 pin definitions

GD32F101Tx QFN36				
Pin Name	Pins	Pin Type <sup>(1)</sup>	I/O Level <sup>(2)</sup>	Functions description
VDD_3	1	P		Default: VDD_3
OSCIN	2	I		Default: OSCIN
OSCOU	3	O		Default: OSCOUT
NRST	4	I/O		Default: NRST
VSSA	5	P		Default: VSSA
VDDA	6	P		Default: VDDA
PA0-WKUP	7	I/O		Default: PA0 Alternate: WKUP, USART1_CTS, ADC0_IN0, TIMER1_CH0, TIMER1_ET1
PA1	8	I/O		Default: PA1 Alternate: USART1_RTS, ADC0_IN1, TIMER1_CH1
PA2	9	I/O		Default: PA2 Alternate: USART1_TX, ADC0_IN2, TIMER1_CH2
PA3	10	I/O		Default: PA3 Alternate: USART1_RX, ADC0_IN3, TIMER1_CH3
PA4	11	I/O		Default: PA4 Alternate: SPI0_NSS, USART1_CK, ADC0_IN4
PA5	12	I/O		Default: PA5 Alternate: SPI0_SCK, ADC0_IN5
PA6	13	I/O		Default: PA6 Alternate: SPI0_MISO, ADC0_IN6, TIMER2_CH0
PA7	14	I/O		Default: PA7 Alternate: SPI0_MOSI, ADC0_IN7, TIMER2_CH1
PB0	15	I/O		Default: PB0 Alternate: ADC0_IN8, TIMER2_CH2
PB1	16	I/O		Default: PB1 Alternate: ADC0_IN9, TIMER2_CH3
PB2	17	I/O	5VT	Default: PB2/BOOT1
VSS_1	18	P		Default: VSS_1
VDD_1	19	P		Default: VDD_1
PA8	20	I/O	5VT	Default: PA8 Alternate: USART0_CK, CK_OUT0
PA9	21	I/O	5VT	Default: PA9 Alternate: USART0_TX
PA10	22	I/O	5VT	Default: PA10 Alternate: USART0_RX
PA11	23	I/O	5VT	Default: PA11



GD32F101Tx QFN36				
Pin Name	Pins	Pin Type <sup>(1)</sup>	I/O Level <sup>(2)</sup>	Functions description
				Alternate: USART0_CTS
PA12	24	I/O	5VT	Default: PA12 Alternate: USART0_RTS
PA13	25	I/O	5VT	Default: JTMS, SWDIO Remap: PA13
VSS_2	26	P		Default: VSS_2
VDD_2	27	P		Default: VDD_2
PA14	28	I/O	5VT	Default: JTCK, SWCLK Remap: PA14
PA15	29	I/O	5VT	Default: JTDI Remap: TIMER1_CH0, TIMER1_ETI, PA15, SPI0_NSS
PB3	30	I/O	5VT	Default: JTDO Remap: PB3, TIMER1_CH1, SPI0_SCK
PB4	31	I/O	5VT	Default: NJTRST Remap: TIMER2_CH0, PB4, SPI0_MISO
PB5	32	I/O		Default: PB5 Alternate: I2C0_SMBA Remap: TIMER2_CH1, SPI0_MOSI
PB6	33	I/O	5VT	Default: PB6 Alternate: I2C0_SCL, TIMER3_CH0 <sup>(3)</sup> Remap: USART0_TX
PB7	34	I/O	5VT	Default: PB7 Alternate: I2C0_SDA, TIMER3_CH1 <sup>(3)</sup> Remap: USART0_RX
BOOT0	35	I		Default: BOOT0
VSS_3	36	P		Default: VSS_3

**Notes:**

(1) Type: I = input, O = output, P = power.

(2) I/O Level: 5VT = 5 V tolerant.

(3) Functions are available in GD32F101T8/B devices.



## 3. Functional description

### 3.1. Arm® Cortex®-M3 core

The Cortex®-M3 processor is the latest generation of Arm® processors for embedded systems. It has been developed to provide a low-cost platform that meets the needs of MCU implementation, with a reduced pin count and low-power consumption, while delivering outstanding computational performance and an advanced system response to interrupts.

- 32-bit Arm® Cortex®-M3 processor core
- Up to 56 MHz operation frequency
- Single-cycle multiplication and hardware divider
- Integrated Nested Vectored Interrupt Controller (NVIC)
- 24-bit SysTick timer

The Cortex®-M3 processor is based on the ARMv7 architecture and supports both Thumb and Thumb-2 instruction sets. Some system peripherals listed below are also provided by Cortex®-M3:

- Internal Bus Matrix connected with ICode bus, DCode bus, system bus, Private Peripheral Bus (PPB) and debug accesses (AHB-AP)
- Nested Vectored Interrupt Controller (NVIC)
- Flash Patch and Breakpoint (FPB)
- Data Watchpoint and Trace (DWT)
- Instrument Trace Macrocell (ITM)
- Memory Protection Unit (MPU)
- Serial Wire JTAG Debug Port (SWJ-DP)
- Trace Port Interface Unit (TPIU)

### 3.2. On-chip memory

- Up to 3072 Kbytes of Flash memory
- The region of the MCU executing instructions without waiting time is up to 256K bytes ( in case that Flash size less than or equal to 256K, all memory is no waiting time). A long delay when CPU fetches the instructions out of the range.
- Up to 80 Kbytes of SRAM

The Arm® Cortex®-M3 processor is structured in Harvard architecture which can use separate buses to fetch instructions and load/store data. 3072 Kbytes of inner Flash at most, which includes code Flash and data Flash, is available for storing programs and data, and there is no waiting time within code Flash area when CPU executes instructions. The [Table 2-4. GD32F101xx memory map](#) shows the memory map of the GD32F101xx series of devices, including code, SRAM, peripheral, and other pre-defined regions.

### 3.3. Clock, reset and supply management

- Internal 8 MHz factory-trimmed RC and external 4 to 16 MHz crystal oscillator
- Internal 40 KHz RC calibrated oscillator and external 32.768 KHz crystal oscillator
- Integrated system clock PLL
- 2.6 to 3.6 V application supply and I/Os
- Supply Supervisor: POR (Power On Reset), PDR (Power Down Reset), and low voltage detector (LVD)

The Clock Control Unit (CCU) provides a range of oscillator and clock functions. These include speed internal RC oscillator and external crystal oscillator, high speed and low speed two types. Several prescalers allow the configuration of the AHB frequency, the high-speed APB (APB2) and the low-speed APB (APB1) domains. The maximum allowed frequency of the AHB and APB domain is 56 MHz. See [Figure 2-8. GD32F101xx clock tree](#) for details on the clock tree.

The Reset Control Unit (RCU) controls three kinds of reset: system reset resets the processor core and peripheral IP components. Power-on reset (POR) and power-down reset (PDR) are always active, and ensures proper operation starting from/down to 2.6 V. The device remains in reset mode when  $V_{DD}$  is below a specified threshold. The embedded low voltage detector (LVD) monitors the power supply, compares it to the voltage threshold and generates an interrupt as a warning message for leading the MCU into security.

Power supply schemes:

- $V_{DD}$  range: 2.6 to 3.6 V, external power supply for I/Os and the internal regulator. Provided externally through  $V_{DD}$  pins.
- $V_{SSA}$ ,  $V_{DDA}$  range: 2.6 to 3.6 V, external analog power supplies for ADC, reset blocks, RCs and PLL.  $V_{DDA}$  and  $V_{SSA}$  must be connected to  $V_{DD}$  and  $V_{SS}$ , respectively.
- $V_{BAT}$  range: 1.8 to 3.6 V, power supply for RTC, external clock 32 kHz oscillator and backup registers (through power switch) when  $V_{DD}$  is not present.

### 3.4. Boot modes

At startup, boot pins are used to select one of three boot options:

- Boot from main flash memory (default)
- Boot from system memory
- Boot from on-chip SRAM

The boot loader is located in the internal boot ROM memory (system memory). It is used to reprogram the Flash memory by using USART0 (PA9 and PA10), if devices are GD32f101xF/G/I/K, USART1 (PA2 and PA3) is also available for boot functions. It also can be used to transfer and update the Flash memory code, the data and the vector table sections. In default condition, boot from bank 0 of Flash memory is selected. It also supports to boot from bank 1 of Flash memory by setting a bit in option bytes.

### 3.5. Power saving modes

The MCU supports three kinds of power saving modes to achieve even lower power consumption. They are sleep mode, deep-sleep mode, and standby mode. These operating modes reduce the power consumption and allow the application to achieve the best balance between the CPU operating time, speed and power consumption.

- **Sleep mode**

In sleep mode, only the clock of CPU core is off. All peripherals continue to operate and any interrupt/event can wake up the system.

- **Deep-sleep mode**

In deep-sleep mode, all clocks in the 1.2V domain are off, and all of the high speed crystal oscillator (IRC8M, HXTAL) and PLL are disabled. Only the contents of SRAM and registers are retained. Any interrupt or wakeup event from EXTI lines can wake up the system from the deep-sleep mode including the 16 external lines, the RTC alarm, the LVD output. When exiting the deep-sleep mode, the IRC8M is selected as the system clock.

- **Standby mode**

In standby mode, the whole 1.2V domain is power off, the LDO is shut down, and all of IRC8M, HXTAL and PLL are disabled. The contents of SRAM and registers (except Backup registers) are lost. There are four wakeup sources for the standby mode, including the external reset from NRST pin, the RTC alarm, the FWDGT reset, and the rising edge on WKUP pin.

### 3.6. Analog to digital converter (ADC)

- 12-bit SAR ADC engine
- Up to 1 MSPS conversion rate
- Conversion range:  $V_{SSA}$  to  $V_{DDA}$  (2.6 to 3.6 V)
- Temperature sensor

Up to two 12-bit 1  $\mu$ s multi-channel ADCs are integrated in the device. Each is a total of up to 16 multiplexed external channels. An analog watchdog block can be used to detect the channels, which are required to remain within a specific threshold window. A configurable channel management block of analog inputs also can be used to perform conversions in single, continuous, scan or discontinuous mode to support more advanced usages.

The ADCs can be triggered from the events generated by the general-purpose timers (TIMERx) with internal connection. The temperature sensor has to generate a voltage that varies linearly with temperature. The conversion range is between  $2.6\text{ V} < V_{DDA} < 3.6\text{ V}$ . The temperature sensor is internally connected to the ADC\_IN16 input channel which is used to convert the sensor output voltage into a digital value.

To ensure a high accuracy on ADC and DAC, the ADC/DAC independent external reference



voltage should be connected to  $V_{REF+}/V_{REF-}$  pins. According to the different packages,  $V_{REF+}$  pin can be connected to  $V_{DDA}$  pin, or external reference voltage,  $V_{REF-}$  pin must be connected to  $V_{SSA}$  pin. The  $V_{REF+}$  pin is only available on no less than 100-pin packages. On less than 100-pin packages, the  $V_{REF+}$  pin is not available and it is internally connected to  $V_{DDA}$ . The  $V_{REF-}$  pin is internally connected to  $V_{SSA}$ .

### 3.7. DMA

- 7 channel DMA0 controller and 5 channel DMA1 controller
- Peripherals supported: Timers, ADC, SPIs, I<sup>2</sup>Cs, USARTs

The flexible general-purpose DMA controllers provide a hardware method of transferring data between peripherals and/or memory without intervention from the CPU, thereby freeing up bandwidth for other system functions. Four types of access method are supported: peripheral to peripheral, peripheral to memory, memory to peripheral, memory to memory.

Each channel is connected to fixed hardware DMA requests. The priorities of DMA channel requests are determined by software configuration and hardware channel number. Transfer size of source and destination are independent and configurable.

### 3.8. General-purpose inputs/outputs (GPIOs)

- Up to 112 fast GPIOs, all mappable on 16 external interrupt vectors (EXTI)
- Analog input/output configurable
- Alternate function input/output configurable

There are up to 112 general purpose I/O pins (GPIO) in GD32F101xx, named PA0 ~ PA15 and PB0 ~ PB15, PC0 ~ PC15, PD0 ~ PD15, PE0 ~ PE15, PF0-PF15, PG0-PG15 to implement logic input/output functions. Each of the GPIO ports has related control and configuration registers to satisfy the requirements of specific applications. The external interrupts on the GPIO pins of the device have related control and configuration registers in the External Interrupt Control Unit (EXTI). The GPIO ports are pin-shared with other alternative functions (AFs) to obtain maximum flexibility on the package pins. Each of the GPIO pins can be configured by software as output (push-pull or open-drain), as input (with or without pull-up or pull-down) or as peripheral alternate function. Most of the GPIO pins are shared with digital or analog alternate functions. All GPIOs are high-current capable except for analog inputs.

### 3.9. Timers and PWM generation

- Up to ten 16-bit general-purpose timers (GPTM), and two 16-bit basic timer (TIMER5 & TIMER6)
- Up to 4 independent channels of PWM, output compare or input capture for each GPTM

and external trigger input

- Encoder interface controller with two inputs using quadrature decoder
- 24-bit SysTick timer down counter
- 2 watchdog timers (Free watchdog timer and window watchdog timer)

The general-purpose timer (GPTM), known as TIMER1 ~ TIMER4, TIMER8 ~ TIMER10, TIMER11 ~ TIMER13 can be used for a variety of purposes including general time, input signal pulse width measurement or output waveform generation such as a single pulse generation or PWM output, up to 4 independent channels for input capture/output compare. The GPTM also supports an encoder interface with two inputs using quadrature decoder.

The basic timer, known as TIMER5 and TIMER6, are mainly used to generate analog trigger and can also be used as simple 16-bit time base.

The GD32F101xx have two watchdog peripherals, free watchdog timer and window watchdog timer. They offer a combination of high safety level, flexibility of use and timing accuracy.

The free watchdog timer includes a 12-bit down-counting counter and an 8-bit prescaler, It is clocked from an independent 40 kHz internal RC and as it operates independently of the main clock, it can operate in deep-sleep and standby modes. It can be used either as a watchdog to reset the device when a problem occurs, or as a free-running timer for application timeout management.

The window watchdog timer is based on a 7-bit down counter that can be set as free-running. It can be used as a watchdog to reset the device when a problem occurs. It is clocked from the main clock. It has an early warning interrupt capability and the counter can be frozen in debug mode.

The SysTick timer is dedicated for OS, but could also be used as a standard down counter. It features:

- A 24-bit down counter
- Auto reload capability
- Maskable system interrupt generation when the counter reaches 0
- Programmable clock source

### 3.10. Real time clock (RTC)

- 32-bit up-counter with a programmable 20-bit prescaler
- Alarm function
- Interrupt and wake-up event

The real time clock is an independent timer which provides a set of continuously running counters which can be used with suitable software to provide a clock/calendar function, and provides an alarm interrupt and an expected interrupt. The RTC features a 32-bit programmable counter for long-term measurement using the compare register to generate an alarm. A 20-bit prescaler is used for the time base clock and is by default configured to

generate a time base of 1 second from a clock at 32.768 kHz from external crystal oscillator.

### 3.11. Inter-integrated circuit (I2C)

- Up to two I2C bus interfaces can support both master and slave mode with a frequency up to 400 kHz
- Provide arbitration function, optional PEC (packet error checking) generation and checking
- Supports 7-bit and 10-bit addressing mode and general call addressing mode

The I2C interface is an internal circuit allowing communication with an external I2C interface which is an industry standard two line serial interface used for connection to external hardware. These two serial lines are known as a serial data line (SDA) and a serial clock line (SCL). The I2C module provides transfer rate of up to 100 KHz in standard mode and up to 400 KHz in fast mode. The I2C module also has an arbitration detect function to prevent the situation where more than one master attempts to transmit data to the I2C bus at the same time. A CRC-8 calculator is also provided in I2C interface to perform packet error checking for I2C data.

### 3.12. Serial peripheral interface (SPI)

- Up to three SPI interfaces with a frequency of up to 18 MHz
- Support both master and slave mode
- Hardware CRC calculation and transmit automatic CRC error checking

The SPI interface uses 4 pins, among which are the serial data input and output lines (MISO & MOSI), the clock line (SCK) and the slave select line (NSS). Both SPIs can be served by the DMA controller. The SPI interface may be used for a variety of purposes, including simple synchronous transfers on two lines with a possible bidirectional data line or reliable communication using CRC checking.

### 3.13. Universal synchronous asynchronous receiver transmitter (USART)

- Up to three USARTs and two UARTs with operating frequency up to 3.5 MHz
- Supports both asynchronous and clocked synchronous serial communication modes
- IrDA SIR encoder and decoder support
- LIN break generation and detection
- USARTs support ISO 7816-3 compliant smart card interface

The USART (USART0, USART1 and USART2) and UART (UART3 & UART4) are used to translate data between parallel and serial interfaces, provides a flexible full duplex data

exchange using synchronous or asynchronous transfer. It is also commonly used for RS-232 standard communication. The USART includes a programmable baud rate generator which is capable of dividing the system clock to produce a dedicated clock for the USART transmitter and receiver. The USART also supports DMA function for high speed data communication except UART4.

### 3.14. External memory controller (EXMC)

- Supported external memory: SRAM, PSRAM, ROM and NOR-Flash, NAND Flash and CF card
- Up to 16-bit data bus
- Support to interface with Motorola 6800 and Intel 8080 type LCD directly

External memory controller (EXMC) is an abbreviation of external memory controller. It is divided into several sub-banks for external device support, each sub-bank has its own chip selection signal but at one time, only one bank can be accessed. The EXMC supports code execution from external memory except NAND Flash and CF card. The EXMC also can be configured to interface with the most common LCD module of Motorola 6800 and Intel 8080 series and reduce the system cost and complexity.

### 3.15. Debug mode

- Serial wire JTAG debug port (SWJ-DP)

The Arm® SWJ-DP Interface is embedded and is a combined JTAG and serial wire debug port that enables either a serial wire debug or a JTAG probe to be connected to the target.

### 3.16. Package and operation temperature

- LQFP144 (GD32F101Zx), LQFP100 (GD32F101Vx), LQFP64 (GD32F101Rx), LQFP48 (GD32F101Cx) and QFN36 (GD32F101Tx)
- Operation temperature range: -40°C to +85°C (industrial level)

## 4. Electrical characteristics

### 4.1. Absolute maximum ratings

The maximum ratings are the limits to which the device can be subjected without permanently damaging the device. Note that the device is not guaranteed to operate properly at the maximum ratings. Exposure to the absolute maximum rating conditions for extended periods may affect device reliability.

**Table 4-1. Absolute maximum ratings<sup>(1)(4)</sup>**

Symbol	Parameter	Min	Max	Unit
V <sub>DD</sub>	External voltage range <sup>(2)</sup>	V <sub>SS</sub> - 0.3	V <sub>SS</sub> + 3.6	V
V <sub>DDA</sub>	External analog supply voltage	V <sub>SSA</sub> - 0.3	V <sub>SSA</sub> + 3.6	V
V <sub>BAT</sub>	External battery supply voltage	V <sub>SS</sub> - 0.3	V <sub>SS</sub> + 3.6	V
V <sub>IN</sub>	Input voltage on 5V tolerant pin <sup>(3)</sup>	V <sub>SS</sub> - 0.3	V <sub>DD</sub> + 3.6	V
	Input voltage on other I/O	V <sub>SS</sub> - 0.3	3.6	V
ΔV <sub>DDX</sub>	Variations between different VDD power pins	—	50	mV
V <sub>SSX</sub> - V <sub>SS</sub>	Variations between different ground pins	—	50	mV
I <sub>IO</sub>	Maximum current for GPIO pins	—	±25	mA
T <sub>A</sub>	Operating temperature range	-40	+85	°C
P <sub>D</sub>	Power dissipation at T <sub>A</sub> = 85°C of LQFP144	—	820	mW
	Power dissipation at T <sub>A</sub> = 85°C of LQFP100	—	697	
	Power dissipation at T <sub>A</sub> = 85°C of LQFP64	—	647	
	Power dissipation at T <sub>A</sub> = 85°C of LQFP48	—	621	
	Power dissipation at T <sub>A</sub> = 85°C of QFN36	—	926	
T <sub>STG</sub>	Storage temperature range	-65	+150	°C
T <sub>J</sub>	Maximum junction temperature	—	125	°C

(1) Guaranteed by design, not tested in production.

(2) All main power and ground pins should be connected to an external power source within the allowable range.

(3) V<sub>IN</sub> maximum value cannot exceed 5.5 V.

(4) It is recommended that V<sub>DD</sub> and V<sub>DDA</sub> are powered by the same source. The maximum difference between V<sub>DD</sub> and V<sub>DDA</sub> does not exceed 300 mV during power-up and operation.

### 4.2. Operating conditions characteristics

**Table 4-2. DC operating conditions**

Symbol	Parameter	Conditions	Min <sup>(1)</sup>	Typ	Max <sup>(1)</sup>	Unit
V <sub>DD</sub>	Supply voltage	—	2.6	3.3	3.6	V
V <sub>DDA</sub>	Analog supply voltage	Same as V <sub>DD</sub>	2.6	3.3	3.6	V
V <sub>BAT</sub>	Battery supply voltage	—	1.8 <sup>(2)</sup>	—	3.6	V

(1) Based on characterization, not tested in production.

(2) In the application which V<sub>BAT</sub> supply the backup domains, if the V<sub>BAT</sub> voltage drops below the minimum value,

when  $V_{DD}$  is powered on again, it is necessary to refresh the registers of backup domains and enable LXTAL again.

**Figure 4-1. Recommended power supply decoupling capacitors<sup>(1)(2)</sup>**

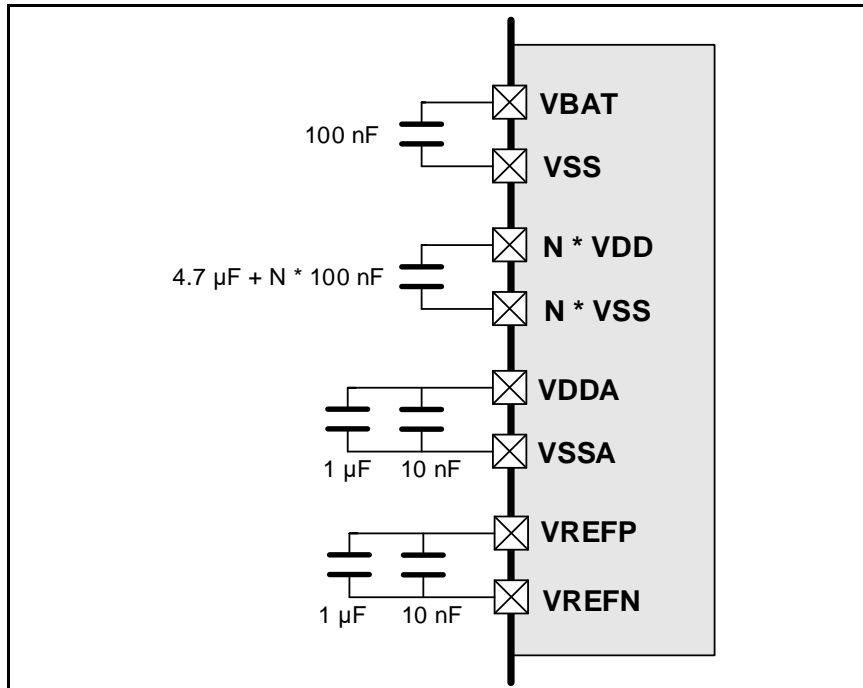

- (1) The VREFP and VREFN pins are only available on no less than 100-pin packages, or else the VREFP and VREFN pins are not available and internally connected to VDDA and VSSA pins. More details refer to **AN076 GD32F10x Hardware Development Guide**.
- (2) All decoupling capacitors need to be as close as possible to the pins on the PCB board.

**Table 4-3. Clock frequency<sup>(1)</sup>**

Symbol	Parameter	Conditions	Min	Max	Unit
$f_{HCLK}$	AHB clock frequency	—	—	56	MHz
$f_{APB1}$	APB1 clock frequency	—	—	56	MHz
$f_{APB2}$	APB2 clock frequency	—	—	56	MHz

- (1) Guaranteed by design, not tested in production.

**Table 4-4. Operating conditions at Power up/ Power down<sup>(1)</sup>**

Symbol	Parameter	Conditions	Min	Max	Unit
$t_{VDD}$	$V_{DD}$ rise time rate	—	0	$\infty$	$\mu\text{s}/\text{V}$
	$V_{DD}$ fall time rate		20	$\infty$	

- (1) Guaranteed by design, not tested in production.

**Table 4-5. Start-up timings of Operating conditions<sup>(1)(2)(3)</sup> (For GD32F101x4/6/8/B devices)**

Symbol	Parameter	Conditions	Typ	Unit
$t_{\text{start-up}}$	Start-up time	Clock source from HXTAL	60	ms
		Clock source from IRC8M	60	

- (1) Based on characterization, not tested in production.
- (2) After power-up, the start-up time is the time between the rising edge of NRST high and the main function.
- (3) PLL is off.

**Table 4-6. Start-up timings of Operating conditions<sup>(1)(2)(3)</sup> (For GD32F101xC/D/E/F/G/K)**

devices)

Symbol	Parameter	Conditions	Typ	Unit
$t_{\text{start-up}}$	Start-up time	Clock source from HXTAL	132	ms
		Clock source from IRC8M	132	

- (1) Based on characterization, not tested in production.
- (2) After power-up, the start-up time is the time between the rising edge of NRST high and the main function.
- (3) PLL is off.

**Table 4-7. Power saving mode wakeup timings characteristics<sup>(1)(2)</sup> (For GD32F101x4/6/8/B devices)**

Symbol	Parameter	Typ	Unit
$t_{\text{Sleep}}$	Wakeup from Sleep mode	4.5	$\mu\text{s}$
$t_{\text{Deep-sleep}}$	Wakeup from Deep-sleep mode (LDO On)	6.5	
	Wakeup from Deep-sleep mode (LDO in low power mode)	6.5	
$t_{\text{Standby}}$	Wakeup from Standby mode	60	ms

- (1) Based on characterization, not tested in production.
- (2) The wakeup time is measured from the wakeup event to the point at which the application code reads the first instruction under the below conditions:  $V_{\text{DD}} = V_{\text{DDA}} = 3.3 \text{ V}$ , IRC8M = System clock = 8 MHz.

**Table 4-8. Power saving mode wakeup timings characteristics<sup>(1)(2)</sup> (For GD32F101xC/D/E/F/G//K devices)**

Symbol	Parameter	Typ	Unit
$t_{\text{Sleep}}$	Wakeup from Sleep mode	4.5	$\mu\text{s}$
$t_{\text{Deep-sleep}}$	Wakeup from Deep-sleep mode (LDO On)	6	
	Wakeup from Deep-sleep mode (LDO in low power mode)	6	
$t_{\text{Standby}}$	Wakeup from Standby mode	119	ms

- (1) Based on characterization, not tested in production.
- (2) The wakeup time is measured from the wakeup event to the point at which the application code reads the first instruction under the below conditions:  $V_{\text{DD}} = V_{\text{DDA}} = 3.3 \text{ V}$ , IRC8M = System clock = 8 MHz.

### 4.3. Power consumption

The power measurements specified in the tables represent that code with data executing from on-chip Flash with the following specifications.

**Table 4-9. Power consumption characteristics (For GD32F101x4/6/8/B devices)<sup>(2)(3)(4)(5)(6)</sup>**

Symbol	Parameter	Conditions	Min	Typ <sup>(1)</sup>	Max	Unit
$I_{\text{DD}} + I_{\text{DDA}}$	Supply current (Run mode)	$V_{\text{DD}} = V_{\text{DDA}} = 3.3 \text{ V}$ , HXTAL = 8 MHz, System clock = 56 MHz, All peripherals enabled	—	21.4	—	mA
		$V_{\text{DD}} = V_{\text{DDA}} = 3.3 \text{ V}$ , HXTAL = 8 MHz, System clock = 56 MHz, All peripherals disabled	—	16.6	—	mA
		$V_{\text{DD}} = V_{\text{DDA}} = 3.3 \text{ V}$ , HXTAL = 8 MHz, System clock = 36 MHz, All peripherals enabled	—	15.5	—	mA



Symbol	Parameter	Conditions	Min	Typ <sup>(1)</sup>	Max	Unit
		$V_{DD} = V_{DDA} = 3.3\text{ V}$ , HXTAL = 8 MHz, System clock = 36 MHz, All peripherals disabled	—	11.5	—	mA
	Supply current (Sleep mode)	$V_{DD} = V_{DDA} = 3.3\text{ V}$ , HXTAL = 8 MHz, System Clock = 56 MHz, CPU clock off, All peripherals enabled	—	9.9	—	mA
		$V_{DD} = V_{DDA} = 3.3\text{ V}$ , HXTAL = 8 MHz, System Clock = 56 MHz, CPU clock off, All peripherals disabled	—	4.0	—	mA
	Supply current (Deep-Sleep mode)	$V_{DD} = V_{DDA} = 3.3\text{ V}$ , LDO in normal power mode, IRC40K off, RTC off, All GPIOs analog mode	—	259		$\mu\text{A}$
		$V_{DD} = V_{DDA} = 3.3\text{ V}$ , LDO in low power mode, IRC40K off, RTC off, All GPIOs analog mode	—	247		$\mu\text{A}$
	Supply current (Standby mode)	$V_{DD} = V_{DDA} = 3.3\text{ V}$ , LXTAL off, IRC40K on, RTC on	—	7.8		$\mu\text{A}$
		$V_{DD} = V_{DDA} = 3.3\text{ V}$ , LXTAL off, IRC40K on, RTC off	—	7.3		$\mu\text{A}$
		$V_{DD} = V_{DDA} = 3.3\text{ V}$ , LXTAL off, IRC40K off, RTC off	—	6.1		$\mu\text{A}$
$I_{BAT}$	Battery supply current (Backup mode)	$V_{DD}$ off, $V_{DDA}$ off, $V_{BAT} = 3.6\text{ V}$ , LXTAL on with external crystal, RTC on	—	17.0	—	$\mu\text{A}$
		$V_{DD}$ off, $V_{DDA}$ off, $V_{BAT} = 3.3\text{ V}$ , LXTAL on with external crystal, RTC on	—	12.7	—	$\mu\text{A}$
		$V_{DD}$ off, $V_{DDA}$ off, $V_{BAT} = 2.6\text{ V}$ , LXTAL on with external crystal, RTC on	—	6.0	—	$\mu\text{A}$
		$V_{DD}$ off, $V_{DDA}$ off, $V_{BAT} = 1.8\text{ V}$ , LXTAL on with external crystal, RTC on	—	2.0	—	$\mu\text{A}$

- (1) Based on characterization, not tested in production.
- (2) Unless otherwise specified, all values given for  $T_A = 25\text{ }^\circ\text{C}$  and test result is mean value.
- (3) When System Clock is less than 4 MHz, an external source is used, and the HXTAL bypass function is needed, no PLL.
- (4) When System Clock is greater than 8 MHz, a crystal 8 MHz is used, and the HXTAL bypass function is closed, using PLL.
- (5) When analog peripheral blocks such as ADCs, HXTAL, LXTAL, IRC8M, or IRC40K are ON, an additional power consumption should be considered.
- (6) All GPIOs are configured as analog mode except standby mode.



**Table 4-10. Power consumption characteristics (For GD32F101xC/D/E/F/G//K devices)**  
(2)(3)(4)(5)(6)

Symbol	Parameter	Conditions	Min	Typ <sup>(1)</sup>	Max	Unit
I <sub>DD+I<sub>D</sub>DA</sub>	Supply current (Run mode)	V <sub>DD</sub> = V <sub>D</sub> DA = 3.3 V, HXTAL = 8 MHz, System clock = 56 MHz, All peripherals enabled	—	27.1	—	mA
		V <sub>DD</sub> = V <sub>D</sub> DA = 3.3 V, HXTAL = 8 MHz, System clock = 56 MHz, All peripherals disabled	—	20.2	—	mA
		V <sub>DD</sub> = V <sub>D</sub> DA = 3.3 V, HXTAL = 8 MHz, System clock = 36 MHz, All peripherals enabled	—	19.4	—	mA
		V <sub>DD</sub> = V <sub>D</sub> DA = 3.3 V, HXTAL = 8 MHz, System clock = 36 MHz, All peripherals disabled	—	13.9	—	mA
	Supply current (Sleep mode)	V <sub>DD</sub> = V <sub>D</sub> DA = 3.3 V, HXTAL = 8 MHz, System Clock = 56 MHz, CPU clock off, All peripherals enabled	—	14.3	—	mA
		V <sub>DD</sub> = V <sub>D</sub> DA = 3.3 V, HXTAL = 8 MHz, System Clock = 56 MHz, CPU clock off, All peripherals disabled	—	4.9	—	mA
	Supply current (Deep-Sleep mode)	V <sub>DD</sub> = V <sub>D</sub> DA = 3.3 V, LDO in normal power mode, IRC40K off, RTC off, All GPIOs analog mode	—	585	—	μA
		V <sub>DD</sub> = V <sub>D</sub> DA = 3.3 V, LDO in low power mode, IRC40K off, RTC off, All GPIOs analog mode	—	573	—	μA
	Supply current (Standby mode)	V <sub>DD</sub> = V <sub>D</sub> DA = 3.3 V, LXTAL off, IRC40K on, RTC on	—	7.8	—	μA
		V <sub>DD</sub> = V <sub>D</sub> DA = 3.3 V, LXTAL off, IRC40K on, RTC off	—	7.4	—	μA
		V <sub>DD</sub> = V <sub>D</sub> DA = 3.3 V, LXTAL off, IRC40K off, RTC off	—	6.2	—	μA
	I <sub>BAT</sub>	Battery supply current (Backup mode)	V <sub>DD</sub> off, V <sub>D</sub> DA off, V <sub>BAT</sub> = 3.6 V, LXTAL on with external crystal, RTC on	—	16.6	—
V <sub>DD</sub> off, V <sub>D</sub> DA off, V <sub>BAT</sub> = 3.3 V, LXTAL on with external crystal, RTC on			—	12.6	—	μA
V <sub>DD</sub> off, V <sub>D</sub> DA off, V <sub>BAT</sub> = 2.6 V, LXTAL on with external crystal, RTC on			—	5.9	—	μA
V <sub>DD</sub> off, V <sub>D</sub> DA off, V <sub>BAT</sub> = 1.8 V, LXTAL on with external crystal, RTC on			—	2.0	—	μA

(1) Based on characterization, not tested in production.

(2) Unless otherwise specified, all values given for T<sub>A</sub> = 25 °C and test result is mean value.

- (3) When System Clock is less than 4 MHz, an external source is used, and the HXTAL bypass function is needed, no PLL.
- (4) When System Clock is greater than 8 MHz, a crystal 8 MHz is used, and the HXTAL bypass function is closed, using PLL.
- (5) When analog peripheral blocks such as ADCs, HXTAL, LXTAL, IRC8M, or IRC40K are ON, an additional power consumption should be considered.
- (6) All GPIOs are configured as analog mode except standby mode.

## 4.4. EMC characteristics

EMS (electromagnetic susceptibility) includes ESD (Electrostatic discharge, positive and negative) and FTB (Burst of Fast Transient voltage, positive and negative) testing result is given in the [Table 4-11. EMS characteristics<sup>\(1\)</sup>](#), based on the EMS levels and classes compliant with IEC 61000 series standard.

**Table 4-11. EMS characteristics<sup>(1)</sup>**

Symbol	Parameter	Conditions	Level/Class
V <sub>ESD</sub>	Voltage applied to all device pins to induce a functional disturbance	V <sub>DD</sub> = 3.3 V, T <sub>A</sub> = 25 °C LQFP144, f <sub>HCLK</sub> = 56 MHz conforms to IEC 61000-4-2	3B
V <sub>FTB</sub>	Fast transient voltage burst applied to induce a functional disturbance through 100 pF on VDD and VSS pins	V <sub>DD</sub> = 3.3 V, T <sub>A</sub> = 25 °C LQFP144, f <sub>HCLK</sub> = 56 MHz conforms to IEC 61000-4-4	4A

(1) Based on characterization, not tested in production.

## 4.5. Power supply supervisor characteristics

**Table 4-12. Power supply supervisor characteristics (For GD32F101x4/6/8/B devices)**

Symbol	Parameter	Conditions	Min	Typ	Max	Unit
V <sub>LVD</sub> <sup>(1)</sup>	Low voltage Detector level selection	LVDT<2:0> = 100(rising edge)	—	2.55	—	
		LVDT<2:0> = 100(falling edge)	—	2.48	—	
		LVDT<2:0> = 101(rising edge)	—	2.66	—	
		LVDT<2:0> = 101(falling edge)	—	2.58	—	
		LVDT<2:0> = 110(rising edge)	—	2.75	—	
		LVDT<2:0> = 110(falling edge)	—	2.69	—	
		LVDT<2:0> = 111(rising edge)	—	2.86	—	
		LVDT<2:0> = 111(falling edge)	—	2.78	—	
V <sub>LVDhyst</sub> <sup>(2)</sup>	LVD hysteresis	—	—	100	—	mV
V <sub>POR</sub> <sup>(1)</sup>	Power on reset threshold	—	—	2.40	—	V



Symbol	Parameter	Conditions	Min	Typ	Max	Unit
$V_{PDR}^{(1)}$	Power down reset threshold		—	2.35	—	V
$V_{PDRhyst}^{(2)}$	PDR hysteresis		—	50	—	mV
$t_{RSTTEMPO}^{(2)}$	Reset temporization		—	2	—	ms

(1) Based on characterization, not tested in production.

(2) Guaranteed by design, not tested in production.

**Table 4-13. Power supply supervisor characteristics (For GD32F101xC/D/E/F/G/K devices)**

Symbol	Parameter	Conditions	Min	Typ	Max	Unit
$V_{LVD}^{(1)}$	Low voltage Detector level selection	LVDT<2:0> = 000(rising edge)	—	2.19	—	V
		LVDT<2:0> = 000(falling edge)	—	2.08	—	
		LVDT<2:0> = 001(rising edge)	—	2.29	—	
		LVDT<2:0> = 001(falling edge)	—	2.19	—	
		LVDT<2:0> = 010(rising edge)	—	2.39	—	
		LVDT<2:0> = 010(falling edge)	—	2.29	—	
		LVDT<2:0> = 011(rising edge)	—	2.5	—	
		LVDT<2:0> = 011(falling edge)	—	2.39	—	
		LVDT<2:0> = 100(rising edge)	—	2.6	—	
		LVDT<2:0> = 100(falling edge)	—	2.48	—	
		LVDT<2:0> = 101(rising edge)	—	2.68	—	
		LVDT<2:0> = 101(falling edge)	—	2.58	—	
		LVDT<2:0> = 110(rising edge)	—	2.79	—	
		LVDT<2:0> = 110(falling edge)	—	2.68	—	
$V_{LVDhyst}^{(2)}$	LVD hysteresis	—	—	100	—	mV
$V_{POR}^{(1)}$	Power on reset threshold		—	2.40	—	V
$V_{PDR}^{(1)}$	Power down reset threshold		—	1.85	—	V
$V_{PDRhyst}^{(2)}$	PDR hysteresis		—	550	—	mV
$t_{RSTTEMPO}^{(2)}$	Reset temporization		—	2	—	ms

(1) Based on characterization, not tested in production.

(2) Guaranteed by design, not tested in production.

## 4.6. Electrical sensitivity

The device is strained in order to determine its performance in terms of electrical sensitivity. Electrostatic discharges (ESD) are applied directly to the pins of the sample. Static latch-up (LU) test is based on the two measurement methods.

**Table 4-14. ESD characteristics<sup>(1)</sup>**

Symbol	Parameter	Conditions	Min	Typ	Max	Unit
$V_{ESD(HBM)}$	Electrostatic discharge voltage (human body model)	$T_A = 25\text{ }^\circ\text{C}$ ; JS-001-2014	—	—	3000	V
$V_{ESD(CDM)}$	Electrostatic discharge voltage (charge device model)	$T_A = 25\text{ }^\circ\text{C}$ ; JS-002-2014	—	—	500	V

(1) Based on characterization, not tested in production.

**Table 4-15. Static latch-up characteristics<sup>(1)</sup>**

Symbol	Parameter	Conditions	Min	Typ	Max	Unit
LU	$I_{test}$	$T_A = 25\text{ }^\circ\text{C}$ ; JESD78	—	—	$\pm 100$	mA
	$V_{supply\ over\ voltage}$		—	—	5.4	V

(1) Based on characterization, not tested in production.

## 4.7. External clock characteristics

**Table 4-16. High speed external clock (HXTAL) generated from a crystal/ceramic characteristics(For GD32F101x4/6/8/B devices)**

Symbol	Parameter	Conditions	Min	Typ	Max	Unit
$f_{HXTAL}^{(1)}$	Crystal or ceramic frequency	$2.6\text{ V} \leq V_{DD} \leq 3.6\text{ V}$	4	8	16	MHz
$R_F^{(2)}$	Feedback resistor	$V_{DD} = 3.3\text{ V}$	—	400	—	k $\Omega$
$C_{HXTAL}^{(2)(3)}$	Recommended matching capacitance on OSCIN and OSCOUT	—	—	20	30	pF
$D_{ucy(HXTAL)}^{(2)}$	Crystal or ceramic duty cycle	—	30	50	70	%
$g_m^{(2)}$	Oscillator transconductance	Startup	—	35	—	mA/V
$I_{DDHXTAL}^{(1)}$	Crystal or ceramic operating current	$V_{DD} = 3.3\text{ V}$ ; $T_A = 25\text{ }^\circ\text{C}$	—	1.3	—	mA
$t_{SUHXTAL}^{(1)}$	Crystal or ceramic startup time	$V_{DD} = 3.3\text{ V}$ ; $T_A = 25\text{ }^\circ\text{C}$	—	3.9	—	ms

(1) Based on characterization, not tested in production.

(2) Guaranteed by design, not tested in production.

(3)  $C_{HXTAL1} = C_{HXTAL2} = 2 \cdot (C_{LOAD} - C_S)$ , For  $C_{HXTAL1}$  and  $C_{HXTAL2}$ , it is recommended matching capacitance on OSCIN and OSCOUT. For  $C_{LOAD}$ , it is crystal/ceramic load capacitance, provided by the crystal or ceramic

manufacturer. For  $C_s$ , it is PCB and MCU pin stray capacitance.

**Table 4-17. High speed external clock (HXTAL) generated from a crystal/ceramic characteristics(For GD32F101xC/D/E/F/G/I/K devices)**

Symbol	Parameter	Conditions	Min	Typ	Max	Unit
$f_{HXTAL}^{(1)}$	Crystal or ceramic frequency	$2.6 V \leq V_{DD} \leq 3.6 V$	4	8	16	MHz
$R_F^{(2)}$	Feedback resistor	$V_{DD} = 3.3 V$	—	400	—	k $\Omega$
$C_{HXTAL}^{(2)(3)}$	Recommended matching capacitance on OSCIN and OSCOUT	—	—	20	30	pF
$D_{ucy(HXTAL)}^{(2)}$	Crystal or ceramic duty cycle	—	30	50	70	%
$g_m^{(2)}$	Oscillator transconductance	Startup	—	35	—	mA/V
$I_{DDHXTAL}^{(1)}$	Crystal or ceramic operating current	$V_{DD} = 3.3 V$ , $T_A = 25^\circ C$	—	1.6	—	mA
$t_{SUHXTAL}^{(1)}$	Crystal or ceramic startup time	$V_{DD} = 3.3 V$ , $T_A = 25^\circ C$	—	0.68	—	ms

(1) Based on characterization, not tested in production.

(2) Guaranteed by design, not tested in production.

(3)  $C_{HXTAL1} = C_{HXTAL2} = 2 * (C_{LOAD} - C_s)$ , For  $C_{HXTAL1}$  and  $C_{HXTAL2}$ , it is recommended matching capacitance on OSCIN and OSCOUT. For  $C_{LOAD}$ , it is crystal/ceramic load capacitance, provided by the crystal or ceramic manufacturer. For  $C_s$ , it is PCB and MCU pin stray capacitance.

**Table 4-18. High speed external clock characteristics (HXTAL in bypass mode)**

Symbol	Parameter	Conditions	Min	Typ	Max	Unit
$f_{HXTAL\_ext}^{(1)}$	External clock source or oscillator frequency	$2.6 V \leq V_{DD} \leq 3.6 V$	1	—	50	MHz
$V_{HXTALH}^{(2)}$	OSCIN input pin high level voltage	$V_{DD} = 3.3 V$	0.7 $V_{DD}$	—	$V_{DD}$	V
$V_{HXTALL}^{(2)}$	OSCIN input pin low level voltage		$V_{SS}$	—	0.3 $V_{DD}$	V
$t_{H/L(HXTAL)}^{(2)}$	OSCIN high or low time	—	5	—	—	ns
$t_{R/F(HXTAL)}^{(2)}$	OSCIN rise or fall time	—	—	—	10	ns
$C_{IN}^{(2)}$	OSCIN input capacitance	—	—	5	—	pF
$D_{ucy(HXTAL)}^{(2)}$	Duty cycle	—	40	—	60	%

(1) Based on characterization, not tested in production.

(2) Guaranteed by design, not tested in production.

**Table 4-19. Low speed external clock (LXTAL) generated from a crystal/ceramic characteristics(For GD32F101x4/6/8/B devices)**

Symbol	Parameter	Conditions	Min	Typ	Max	Unit
$f_{LXTAL}^{(1)}$	Crystal or ceramic frequency	$V_{DD} = 3.3 V$	—	32.768	—	kHz
$C_{LXTAL}^{(2)(3)}$	Recommended matching capacitance on OSC32IN and OSC32OUT	—	—	10	—	pF
$D_{ucy(LXTAL)}^{(2)}$	Crystal or ceramic duty	—	30	—	70	%



Symbol	Parameter	Conditions	Min	Typ	Max	Unit
	cycle					
$g_m^{(2)}$	Oscillator transconductance	—	—	23	—	$\mu A/V$
$I_{DDLXTAL}^{(1)}$	Crystal or ceramic operating current	—	—	12	—	$\mu A$
$t_{SULXTAL}^{(1)(4)}$	Crystal or ceramic startup time	—	—	0.28	—	s

- (1) Based on characterization, not tested in production.
- (2) Guaranteed by design, not tested in production.
- (3)  $C_{LXTAL1} = C_{LXTAL2} = 2 * (C_{LOAD} - C_S)$ , For  $C_{LXTAL1}$  and  $C_{LXTAL2}$ , it is recommended matching capacitance on OSC32IN and OSC32OUT. For  $C_{LOAD}$ , it is crystal/ceramic load capacitance, provided by the crystal or ceramic manufacturer. For  $C_S$ , it is PCB and MCU pin stray capacitance.
- (4)  $t_{SULXTAL}$  is the startup time measured from the moment it is enabled (by software) to the 32.768 kHz oscillator stabilization flag is SET. This value varies significantly with the crystal manufacturer.

**Table 4-20. Low speed external clock (LXTAL) generated from a crystal/ceramic characteristics (For GD32F101xC/D/E/F/G/I/K devices)**

Symbol	Parameter	Conditions	Min	Typ	Max	Unit
$f_{LXTAL}^{(1)}$	Crystal or ceramic frequency	$V_{DD} = 3.3 V$	—	32.768	—	kHz
$C_{LXTAL}^{(2)(3)}$	Recommended matching capacitance on OSC32IN and OSC32OUT	—	—	10	—	pF
$D_{Dcy(LXTAL)}^{(2)}$	Crystal or ceramic duty cycle	—	30	—	70	%
$g_m^{(2)}$	Oscillator transconductance	—	—	23	—	$\mu A/V$
$I_{DDLXTAL}^{(1)}$	Crystal or ceramic operating current	—	—	11.6	—	$\mu A$
$t_{SULXTAL}^{(1)(4)}$	Crystal or ceramic startup time	—	—	0.39	—	s

- (1) Based on characterization, not tested in production.
- (2) Guaranteed by design, not tested in production.
- (3)  $C_{LXTAL1} = C_{LXTAL2} = 2 * (C_{LOAD} - C_S)$ , For  $C_{LXTAL1}$  and  $C_{LXTAL2}$ , it is recommended matching capacitance on OSC32IN and OSC32OUT. For  $C_{LOAD}$ , it is crystal/ceramic load capacitance, provided by the crystal or ceramic manufacturer. For  $C_S$ , it is PCB and MCU pin stray capacitance.
- (4)  $t_{SULXTAL}$  is the startup time measured from the moment it is enabled (by software) to the 32.768 kHz oscillator stabilization flag is SET. This value varies significantly with the crystal manufacturer.

**Table 4-21. Low speed external user clock characteristics (LXTAL in bypass mode)**

Symbol	Parameter	Conditions	Min	Typ	Max	Unit
$f_{LXTAL\_ext}^{(1)}$	External clock source or oscillator frequency	$V_{DD} = 3.3\text{ V}$	—	32.768	1000	kHz
$V_{LXTALH}^{(2)}$	OSC32IN input pin high level voltage	—	$0.7 V_{DD}$	—	$V_{DD}$	V
$V_{LXTALL}^{(2)}$	OSC32IN input pin low level voltage	—	$V_{SS}$	—	$0.3 V_{DD}$	
$t_{H/L(LXTAL)}^{(2)}$	OSC32IN high or low time	—	450	—	—	ns
$t_{R/F(LXTAL)}^{(2)}$	OSC32IN rise or fall time	—	—	—	50	
$C_{IN}^{(2)}$	OSC32IN input capacitance	—	—	5	—	pF
$Ducy_{(LXTAL)}^{(2)}$	Duty cycle	—	30	50	70	%

(1) Based on characterization, not tested in production.

(2) Guaranteed by design, not tested in production.

## 4.8. Internal clock characteristics

**Table 4-22. High speed internal clock (IRC8M) characteristics (For GD32F101x4/6/8/B devices)**

Symbol	Parameter	Conditions	Min	Typ	Max	Unit
$f_{IRC8M}$	High Speed Internal Oscillator (IRC8M) frequency	$V_{DD} = V_{DDA} = 3.3\text{ V}$	—	8	—	MHz
$ACC_{IRC8M}$	IRC8M oscillator Frequency accuracy, Factory-trimmed	$V_{DD} = V_{DDA} = 3.3\text{ V}$ , $T_A = -40\text{ °C} \sim +85\text{ °C}$	-2.5	—	+2.5	%
		$V_{DD} = V_{DDA} = 3.3\text{ V}$ , $T_A = 25\text{ °C}$	-1.0	—	+1.0	%
	IRC8M oscillator Frequency accuracy, User trimming step <sup>(1)</sup>	—	—	0.5	—	%
$Ducy_{IRC8M}^{(2)}$	IRC8M oscillator duty cycle	$V_{DD} = V_{DDA} = 3.3\text{ V}$	45	50	55	%
$I_{DDAIRC8M}^{(1)}$	IRC8M oscillator operating current	$V_{DD} = V_{DDA} = 3.3\text{ V}$ , $T_A = 25\text{ °C}$	—	87	—	$\mu\text{A}$
$t_{SUIRC8M}^{(1)}$	IRC8M oscillator startup time	$V_{DD} = V_{DDA} = 3.3\text{ V}$ , $T_A = 25\text{ °C}$	—	2.5	—	$\mu\text{s}$

(1) Based on characterization, not tested in production.

(2) Guaranteed by design, not tested in production.

**Table 4-23. High speed internal clock (IRC8M) characteristics (For GD32F101x4/6/8/B devices)**



**GD32F101xC/D/E/F/G//K devices)**

Symbol	Parameter	Conditions	Min	Typ	Max	Unit
$f_{IRC8M}$	High Speed Internal Oscillator (IRC8M) frequency	$V_{DD} = V_{DDA} = 3.3 V$	—	8	—	MHz
$ACC_{IRC8M}$	IRC8M oscillator Frequency accuracy, Factory-trimmed	$V_{DD} = V_{DDA} = 3.3 V,$ $T_A = -40^{\circ}C \sim +85^{\circ}C$	-2.5	—	+2.5	%
		$V_{DD} = V_{DDA} = 3.3 V, T_A = 25^{\circ}C$	-1.0	—	+1.0	%
$ACC_{IRC8M}$	IRC8M oscillator Frequency accuracy, User trimming step <sup>(1)</sup>	—	—	0.5	—	%
$Ducy_{IRC8M}$ <sup>(2)</sup>	IRC8M oscillator duty cycle	$V_{DD} = V_{DDA} = 3.3 V$	45	50	55	%
$I_{DDAIRC8M}$ <sup>(1)</sup>	IRC8M oscillator operating current	$V_{DD} = V_{DDA} = 3.3 V,$ $T_A = 25^{\circ}C$	—	62	—	$\mu A$
$t_{SUIRC8M}$ <sup>(1)</sup>	IRC8M oscillator startup time	$V_{DD} = V_{DDA} = 3.3 V,$ $T_A = 25^{\circ}C$	—	0.64	—	$\mu s$

(1) Based on characterization, not tested in production.

(2) Guaranteed by design, not tested in production.

**Table 4-24. Low speed internal clock (IRC40K) characteristics (For GD32F101x4/6/8/B devices)**

Symbol	Parameter	Conditions	Min	Typ	Max	Unit
$f_{IRC40K}$ <sup>(1)</sup>	Low Speed Internal oscillator (IRC40K) frequency	$V_{DD} = V_{DDA} = 3.3 V,$ $T_A = -40^{\circ}C \sim +85^{\circ}C$	20	40	60	kHz
$I_{DDAIRC40K}$ <sup>(2)</sup>	IRC40K oscillator operating current	$V_{DD} = V_{DDA} = 3.3 V,$ $T_A = 25^{\circ}C$	—	1.3	—	$\mu A$
$t_{SUIRC40K}$ <sup>(2)</sup>	IRC40K oscillator startup time	$V_{DD} = V_{DDA} = 3.3 V,$ $T_A = 25^{\circ}C$	—	113	—	$\mu s$

(1) Guaranteed by design, not tested in production.

(2) Based on characterization, not tested in production.

**Table 4-25. Low speed internal clock (IRC40K) characteristics (For GD32F101xC/D/E/F/G//K devices)**

Symbol	Parameter	Conditions	Min	Typ	Max	Unit
$f_{IRC40K}$ <sup>(1)</sup>	Low Speed Internal oscillator (IRC40K) frequency	$V_{DD} = V_{DDA} = 3.3 V,$ $T_A = -40^{\circ}C \sim +85^{\circ}C$	20	40	60	kHz
$I_{DDAIRC40K}$ <sup>(2)</sup>	IRC40K oscillator operating current	$V_{DD} = V_{DDA} = 3.3 V,$ $T_A = 25^{\circ}C$	—	1.2	—	$\mu A$
$t_{SUIRC40K}$ <sup>(2)</sup>	IRC40K oscillator startup time	$V_{DD} = V_{DDA} = 3.3 V,$ $T_A = 25^{\circ}C$	—	124	—	$\mu s$

(1) Guaranteed by design, not tested in production.

(2) Based on characterization, not tested in production.





## 4.9. PLL characteristics

**Table 4-26. PLL characteristics**

Symbol	Parameter	Conditions	Min	Typ	Max	Unit
$f_{PLLIN}^{(1)}$	PLL input clock frequency	—	1	—	25	MHz
$f_{PLLOUT}^{(2)}$	PLL output clock frequency	—	16	—	108	MHz
$f_{VCO}^{(2)}$	PLL VCO output clock frequency	—	32	—	216	MHz
$t_{LOCK}^{(2)}$	PLL lock time	—	—	—	300	$\mu$ s

(1) Based on characterization, not tested in production.

(2) Guaranteed by design, not tested in production.

## 4.10. Memory characteristics

**Table 4-27. Flash memory characteristics (For GD32F101x4/6/8/B devices)**

Symbol	Parameter	Conditions	Min <sup>(1)</sup>	Typ <sup>(1)</sup>	Max <sup>(2)</sup>	Unit
$PE_{CYC}$	Number of guaranteed program /erase cycles before failure (Endurance)	$T_A = -40\text{ }^\circ\text{C} \sim +85\text{ }^\circ\text{C}$	100	—	—	kcycles
$t_{RET}$	Data retention time	—	—	20	—	years
$t_{PROG}$	Word programming time	$T_A = -40\text{ }^\circ\text{C} \sim +85\text{ }^\circ\text{C}$	—	37.5	105	$\mu$ s
$t_{ERASE}$	Page erase time	$T_A = -40\text{ }^\circ\text{C} \sim +85\text{ }^\circ\text{C}$	—	50	400	ms
$t_{MERASE(16K)}$	Mass erase time	$T_A = -40\text{ }^\circ\text{C} \sim +85\text{ }^\circ\text{C}$	—	0.3	3	s
$t_{MERASE(32K)}$	Mass erase time	$T_A = -40\text{ }^\circ\text{C} \sim +85\text{ }^\circ\text{C}$	—	0.6	6	s
$t_{MERASE(64K)}$	Mass erase time	$T_A = -40\text{ }^\circ\text{C} \sim +85\text{ }^\circ\text{C}$	—	1.2	12	s
$t_{MERASE(128K)}$	Mass erase time	$T_A = -40\text{ }^\circ\text{C} \sim +85\text{ }^\circ\text{C}$	—	2.4	24	s

(1) Based on characterization, not tested in production.

(2) Guaranteed by design, not tested in production.

**Table 4-28. Flash memory characteristics (For GD32F101xC/D/E/F/G/VK devices)**

Symbol	Parameter	Conditions	Min <sup>(1)</sup>	Typ <sup>(1)</sup>	Max <sup>(2)</sup>	Unit
$PE_{CYC}$	Number of guaranteed program /erase cycles before failure (Endurance)	$T_A = -40\text{ }^\circ\text{C} \sim +85\text{ }^\circ\text{C}$	100	—	—	kcycles
$t_{RET}$	Data retention time	—	—	20	—	years
$t_{PROG}$	Word programming time	$T_A = -40\text{ }^\circ\text{C} \sim +85\text{ }^\circ\text{C}$	—	37.5	105/170 <sup>(3)</sup>	$\mu$ s
$t_{ERASE}$	Page erase time	$T_A = -40\text{ }^\circ\text{C} \sim +85\text{ }^\circ\text{C}$	—	50	400/500 <sup>(4)</sup>	ms
$t_{MERASE(256K)}$	Mass erase time	$T_A = -40\text{ }^\circ\text{C} \sim +85\text{ }^\circ\text{C}$	—	2.4	24	s
$t_{MERASE(512K)}$	Mass erase time	$T_A = -40\text{ }^\circ\text{C} \sim +85\text{ }^\circ\text{C}$	—	8	64	s
$t_{MERASE(1024K)}$	Mass erase time	$T_A = -40\text{ }^\circ\text{C} \sim +85\text{ }^\circ\text{C}$	—	16	128	s
$t_{MERASE(3072K)}$	Mass erase time	$T_A = -40\text{ }^\circ\text{C} \sim +85\text{ }^\circ\text{C}$	—	64	512	s

(1) Based on characterization, not tested in production.

- (2) Guaranteed by design, not tested in production.
- (3) Flash memory with 256K is 105 us and flash memory >256K is 170 us.
- (4) Flash memory with 256K is 400 ms and flash memory >256K is 500 ms.

## 4.11. NRST pin characteristics

Table 4-29. NRST pin characteristics

Symbol	Parameter	Conditions	Min	Typ	Max	Unit
$V_{IL(NRST)}^{(1)}$	NRST Input low level voltage	$V_{DD} = V_{DDA} = 2.6\text{ V}$	-0.3	—	$0.3 V_{DD}$	V
$V_{IH(NRST)}^{(1)}$	NRST Input high level voltage		$0.7 V_{DD}$	—	$V_{DD} + 0.3$	
$V_{hyst}^{(1)}$	Schmidt trigger Voltage hysteresis		—	350	—	mV
$V_{IL(NRST)}^{(1)}$	NRST Input low level voltage	$V_{DD} = V_{DDA} = 3.3\text{ V}$	-0.3	—	$0.3 V_{DD}$	V
$V_{IH(NRST)}^{(1)}$	NRST Input high level voltage		$0.7 V_{DD}$	—	$V_{DD} + 0.3$	
$V_{hyst}^{(1)}$	Schmidt trigger Voltage hysteresis		—	360	—	mV
$V_{IL(NRST)}^{(1)}$	NRST Input low level voltage	$V_{DD} = V_{DDA} = 3.6\text{ V}$	-0.3	—	$0.3 V_{DD}$	V
$V_{IH(NRST)}^{(1)}$	NRST Input high level voltage		$0.7 V_{DD}$	—	$V_{DD} + 0.3$	
$V_{hyst}^{(1)}$	Schmidt trigger Voltage hysteresis		—	370	—	mV
$R_{pu}^{(2)}$	Pull-up equivalent resistor	—	—	40	—	k $\Omega$

- (1) Based on characterization, not tested in production.
- (2) Guaranteed by design, not tested in production.

Figure 4-2. Recommended external NRST pin circuit<sup>(1)</sup>

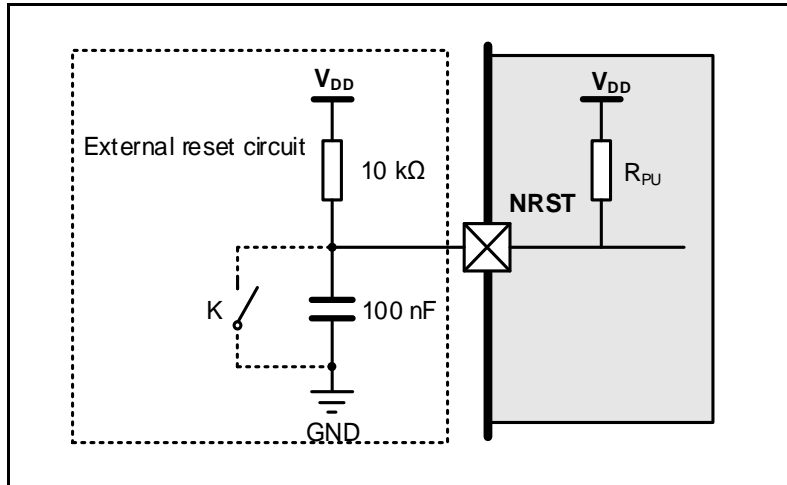

- (1) Unless the voltage on NRST pin go below  $V_{IL(NRST)}$  level, the device would not generate a reliable reset.

## 4.12. GPIO characteristics

Table 4-30. I/O port DC characteristics<sup>(1)(3)</sup> (For GD32F101x4/6/8/B devices)

Symbol	Parameter	Conditions	Min	Typ	Max	Unit
$V_{IL}$	Standard IO Low level input voltage	$2.6\text{ V} \leq V_{DD} = V_{DDA} \leq 3.6\text{ V}$	—	—	$0.3 V_{DD}$	V
	5V-tolerant IO Low level	$2.6\text{ V} \leq V_{DD} = V_{DDA} \leq 3.6\text{ V}$	—	—	$0.3 V_{DD}$	V



Symbol	Parameter	Conditions	Min	Typ	Max	Unit	
	input voltage						
V <sub>IH</sub>	Standard IO Low level input voltage	2.6 V ≤ V <sub>DD</sub> = V <sub>DDA</sub> ≤ 3.6 V	0.7 V <sub>DD</sub>	—	—	V	
	5V-tolerant IO Low level input voltage	2.6 V ≤ V <sub>DD</sub> = V <sub>DDA</sub> ≤ 3.6 V	0.7 V <sub>DD</sub>	—	—	V	
R <sub>PU</sub> (2)	Internal pull-up resistor	All pins	V <sub>IN</sub> = V <sub>SS</sub>	—	40	—	kΩ
		PA10	—	—	10	—	
R <sub>PD</sub> (2)	Internal pull-down resistor	All pins	V <sub>IN</sub> = V <sub>DD</sub>	—	40	—	kΩ
		PA10	—	—	10	—	
IO_Speed=50MHz							
V <sub>OL</sub>	Low level output voltage for an IO Pin (I <sub>IO</sub> = +4 mA)	V <sub>DD</sub> = 2.6V	—	0.12	—	V	
		V <sub>DD</sub> = 3.3 V	—	0.1	—		
		V <sub>DD</sub> = 3.6V	—	0.1	—		
	Low level output voltage for an IO Pin (I <sub>IO</sub> = +12 mA)	V <sub>DD</sub> = 2.6V	—	0.38	—		
		V <sub>DD</sub> = 3.3 V	—	0.32	—		
		V <sub>DD</sub> = 3.6V	—	0.3	—		
V <sub>OH</sub>	High level output voltage for an IO Pin (I <sub>IO</sub> = +8 mA)	V <sub>DD</sub> = 2.6V	—	2.32	—	V	
		V <sub>DD</sub> = 3.3 V	—	3.06	—		
		V <sub>DD</sub> = 3.6V	—	3.37	—		
	High level output voltage for an IO Pin (I <sub>IO</sub> = +15 mA)	V <sub>DD</sub> = 2.6V	—	2.03	—		
		V <sub>DD</sub> = 3.3 V	—	2.76	—		
		V <sub>DD</sub> = 3.6V	—	3.09	—		
IO_Speed=10MHz							
V <sub>OL</sub>	Low level output voltage for an IO Pin (I <sub>IO</sub> = +4 mA)	V <sub>DD</sub> = 2.6V	—	0.29	—	V	
		V <sub>DD</sub> = 3.3 V	—	0.26	—		
		V <sub>DD</sub> = 3.6V	—	0.25	—		
	Low level output voltage for an IO Pin (I <sub>IO</sub> = +8 mA)	V <sub>DD</sub> = 2.6V	—	0.65	—		
		V <sub>DD</sub> = 3.3 V	—	0.51	—		
		V <sub>DD</sub> = 3.6V	—	0.62	—		
V <sub>OH</sub>	High level output voltage for an IO Pin (I <sub>IO</sub> = +8 mA)	V <sub>DD</sub> = 2.6V	—	1.94	—	V	
		V <sub>DD</sub> = 3.3 V	—	2.78	—		
		V <sub>DD</sub> = 3.6V	—	3.11	—		
	High level output voltage for an IO Pin (I <sub>IO</sub> = +10mA)	V <sub>DD</sub> = 2.6V	—	1.71	—		



Symbol	Parameter	Conditions	Min	Typ	Max	Unit
	High level output voltage for an IO Pin ( $I_{IO} = +15\text{mA}$ )	$V_{DD} = 3.3\text{ V}$	—	2.18	—	
		$V_{DD} = 3.6\text{V}$	—	2.85	—	
<b>IO_Speed=2MHz</b>						
$V_{OL}$	Low level output voltage for an IO Pin ( $I_{IO} = +4\text{ mA}$ )	$V_{DD} = 2.6\text{V}$	—	0.59	—	V
		$V_{DD} = 3.3\text{ V}$	—	0.54	—	
		$V_{DD} = 3.6\text{V}$	—	0.51	—	
$V_{OH}$	High level output voltage for an IO Pin ( $I_{IO} = +2\text{mA}$ )	$V_{DD} = 2.6\text{V}$	—	2.14	—	V
		$V_{DD} = 3.3\text{ V}$	—	2.53	—	
	High level output voltage for an IO Pin ( $I_{IO} = +4\text{mA}$ )	$V_{DD} = 3.6\text{V}$	—	2.89	—	

- (1) Based on characterization, not tested in production.
- (2) Guaranteed by design, not tested in production.
- (3) All pins except PC13 / PC14 / PC15. Since PC13 to PC15 are supplied through the Power Switch, which can only be obtained by a small current, the speed of GPIOs PC13 to PC15 should not exceed 2 MHz when they are in output mode (maximum load: 30 pF).

**Table 4-31. I/O port DC characteristics<sup>(1)(3)</sup> (For GD32F101xC/D/E/F/G/I/K devices)**

Symbol	Parameter	Conditions	Min	Typ	Max	Unit	
$V_{IL}$	Standard IO Low level input voltage	$2.6\text{ V} \leq V_{DD} = V_{DDA} \leq 3.6\text{ V}$	—	—	$0.3 V_{DD}$	V	
	5V-tolerant IO Low level input voltage	$2.6\text{ V} \leq V_{DD} = V_{DDA} \leq 3.6\text{ V}$	—	—	$0.3 V_{DD}$	V	
$V_{IH}$	Standard IO Low level input voltage	$2.6\text{ V} \leq V_{DD} = V_{DDA} \leq 3.6\text{ V}$	$0.7 V_{DD}$	—	—	V	
	5V-tolerant IO Low level input voltage	$2.6\text{ V} \leq V_{DD} = V_{DDA} \leq 3.6\text{ V}$	$0.7 V_{DD}$	—	—	V	
$R_{PU}^{(2)}$	Internal pull-up resistor	All pins	$V_{IN} = V_{SS}$	—	40	—	kΩ
		PA10	—	—	10	—	
$R_{PD}^{(2)}$	Internal pull-down resistor	All pins	$V_{IN} = V_{DD}$	—	40	—	kΩ
		PA10	—	—	10	—	
<b>IO_Speed=50MHz</b>							
$V_{OL}$	Low level output voltage for an IO Pin ( $I_{IO} = +8\text{ mA}$ )	$V_{DD} = 2.6\text{V}$	—	0.27	—	V	
		$V_{DD} = 3.3\text{ V}$	—	0.23	—		
		$V_{DD} = 3.6\text{V}$	—	0.22	—		
	Low level output voltage for an IO Pin ( $I_{IO} = +12\text{mA}$ )	$V_{DD} = 2.6\text{V}$	—	0.43	—		
		$V_{DD} = 3.3\text{ V}$	—	0.66	—		
		$V_{DD} = 3.6\text{V}$	—	0.61	—		



Symbol	Parameter	Conditions	Min	Typ	Max	Unit
V <sub>OH</sub>	High level output voltage for an IO Pin (I <sub>IO</sub> = +8 mA)	V <sub>DD</sub> = 2.6V	—	2.3	—	V
		V <sub>DD</sub> = 3.3 V	—	3.05	—	
		V <sub>DD</sub> = 3.6V	—	3.36	—	
	High level output voltage for an IO Pin (I <sub>IO</sub> = +10 mA)	V <sub>DD</sub> = 2.6V	—	2.21	—	
		V <sub>DD</sub> = 3.3 V	—	2.59	—	
		V <sub>DD</sub> = 3.6V	—	2.95	—	
<b>IO_Speed=10MHz</b>						
V <sub>OL</sub>	Low level output voltage for an IO Pin (I <sub>IO</sub> = +8 mA)	V <sub>DD</sub> = 2.6V	—	0.43	—	V
		V <sub>DD</sub> = 3.3 V	—	0.36	—	
		V <sub>DD</sub> = 3.6V	—	0.34	—	
	Low level output voltage for an IO Pin (I <sub>IO</sub> = +15 mA)	V <sub>DD</sub> = 2.6V	—	—	—	
		V <sub>DD</sub> = 3.3 V	—	0.78	—	
		V <sub>DD</sub> = 3.6V	—	0.72	—	
V <sub>OH</sub>	High level output voltage for an IO Pin (I <sub>IO</sub> = +8 mA)	V <sub>DD</sub> = 2.6V	—	2.06	—	V
		V <sub>DD</sub> = 3.3 V	—	2.87	—	
		V <sub>DD</sub> = 3.6V	—	3.2	—	
	High level output voltage for an IO Pin (I <sub>IO</sub> = +15mA)	V <sub>DD</sub> = 2.6V	—	—	—	
		V <sub>DD</sub> = 3.3 V	—	2.39	—	
		V <sub>DD</sub> = 3.6V	—	2.77	—	
<b>IO_Speed=2MHz</b>						
V <sub>OL</sub>	Low level output voltage for an IO Pin (I <sub>IO</sub> = +4 mA)	V <sub>DD</sub> = 2.6V	—	0.44	—	V
		V <sub>DD</sub> = 3.3 V	—	0.36	—	
		V <sub>DD</sub> = 3.6V	—	0.34	—	
V <sub>OH</sub>	High level output voltage for an IO Pin (I <sub>IO</sub> = +4mA)	V <sub>DD</sub> = 2.6V	—	2.22	—	V
		V <sub>DD</sub> = 3.3 V	—	2.99	—	
		V <sub>DD</sub> = 3.6V	—	3.31	—	

- (1) Based on characterization, not tested in production.
- (2) Guaranteed by design, not tested in production.
- (3) All pin except PC13 / PC14 / PC15. Since PC13 to PC15 are supplied through the Power Switch, which can only be obtained by a small current, the speed of GPIOs PC13 to PC15 should not exceed 2 MHz when they are in output mode (maximum load: 30 pF).

**Table 4-32. I/O port AC characteristics<sup>(1)(2)(4)</sup> (For GD32F101x4/6/8/B devices)**

GPIOx_MDy[1:0] bit value <sup>(3)</sup>	Parameter	Conditions	Typ	Unit
GPIOx_CTL->MDy[1:0]=10 (IO_Speed = 2MHz)	T <sub>Rise</sub> /T <sub>Fall</sub>	2.6 ≤ V <sub>DD</sub> ≤ 3.6 V, C <sub>L</sub> = 10 pF	48.6	ns
		2.6 ≤ V <sub>DD</sub> ≤ 3.6 V, C <sub>L</sub> = 30 pF	59.4	
		2.6 ≤ V <sub>DD</sub> ≤ 3.6 V, C <sub>L</sub> = 50 pF	68.4	
GPIOx_CTL->MDy[1:0] = 01 (IO_Speed = 10MHz)	T <sub>Rise</sub> /T <sub>Fall</sub>	2.6 ≤ V <sub>DD</sub> ≤ 3.6 V, C <sub>L</sub> = 10 pF	16	ns
		2.6 ≤ V <sub>DD</sub> ≤ 3.6 V, C <sub>L</sub> = 30 pF	19.4	



GPIOx_MDy[1:0] bit value <sup>(3)</sup>	Parameter	Conditions	Typ	Unit
		$2.6 \leq V_{DD} \leq 3.6 \text{ V}, C_L = 50 \text{ pF}$	25.2	
GPIOx_CTL->MDy[1:0]=11 (IO_Speed = 50MHz)	$T_{Rise}/T_{Fall}$	$2.6 \leq V_{DD} \leq 3.6 \text{ V}, C_L = 10 \text{ pF}$	2.6	ns
		$2.6 \leq V_{DD} \leq 3.6 \text{ V}, C_L = 30 \text{ pF}$	3.2	
		$2.6 \leq V_{DD} \leq 3.6 \text{ V}, C_L = 50 \text{ pF}$	4.2	

- (1) Based on characterization, not tested in production.
- (2) Unless otherwise specified, all test results given for  $T_A = 25 \text{ }^\circ\text{C}$ .
- (3) The I/O speed is configured using the GPIOx\_CTL -> MDy[1:0] bits.
- (4) Only for reference, Depending on user's design.

**Table 4-33. I/O port AC characteristics<sup>(1)(2)(4)</sup> (For GD32F101xC/D/E/F/G/I/K devices)**

GPIOx_MDy[1:0] bit value <sup>(3)</sup>	Parameter	Conditions	Typ	Unit
GPIOx_CTL->MDy[1:0]=10 (IO_Speed = 2MHz)	$T_{Rise}/T_{Fall}$	$2.6 \leq V_{DD} \leq 3.6 \text{ V}, C_L = 10 \text{ pF}$	49.2	ns
		$2.6 \leq V_{DD} \leq 3.6 \text{ V}, C_L = 30 \text{ pF}$	60	
		$2.6 \leq V_{DD} \leq 3.6 \text{ V}, C_L = 50 \text{ pF}$	70.4	
GPIOx_CTL->MDy[1:0] = 01 (IO_Speed = 10MHz)	$T_{Rise}/T_{Fall}$	$2.6 \leq V_{DD} \leq 3.6 \text{ V}, C_L = 10 \text{ pF}$	23.4	ns
		$2.6 \leq V_{DD} \leq 3.6 \text{ V}, C_L = 30 \text{ pF}$	27	
		$2.6 \leq V_{DD} \leq 3.6 \text{ V}, C_L = 50 \text{ pF}$	32	
GPIOx_CTL->MDy[1:0]=11 (IO_Speed = 50MHz)	$T_{Rise}/T_{Fall}$	$2.6 \leq V_{DD} \leq 3.6 \text{ V}, C_L = 10 \text{ pF}$	3.3	ns
		$2.6 \leq V_{DD} \leq 3.6 \text{ V}, C_L = 30 \text{ pF}$	3.5	
		$2.6 \leq V_{DD} \leq 3.6 \text{ V}, C_L = 50 \text{ pF}$	3.6	

- (1) Based on characterization, not tested in production.
- (2) Unless otherwise specified, all test results given for  $T_A = 25 \text{ }^\circ\text{C}$ .
- (3) The I/O speed is configured using the GPIOx\_CTL -> MDy[1:0] bits.
- (4) Only for reference, Depending on user's design.

### 4.13. ADC characteristics

**Table 4-34. ADC characteristics (For GD32F101x4/6/8/B devices)**

Symbol	Parameter	Conditions	Min	Typ	Max	Unit
$V_{DDA}^{(1)}$	Operating voltage	—	2.6	3.3	3.6	V
$V_{IN}^{(1)}$	ADC input voltage range	16 external; 2 internal	0	—	$V_{REFP}$	V
$V_{REFP}^{(2)}$	Positive Reference Voltage	—	2.6	—	$V_{DDA}$	V
$V_{REFN}^{(2)}$	Negative Reference Voltage	—	—	$V_{SSA}$	—	V
$f_{ADC}^{(1)}$	ADC clock	—	0.6	—	14	MHz
$f_s^{(1)}$	Sampling rate	12-bit	0.04	—	1	MSP S
$R_{AIN}^{(2)}$	External input impedance	See <a href="#">Equation 1</a>	—	—	54.8	kΩ
$R_{ADC}^{(2)}$	Input sampling switch resistance	—	—	—	0.2	kΩ
$C_{ADC}^{(2)}$	Input sampling capacitance	No pin/pad capacitance included	—	—	32	pF
$t_s^{(2)}$	Sampling time	$f_{ADC} = 14 \text{ MHz}$	0.11	—	17.11	μs



Symbol	Parameter	Conditions	Min	Typ	Max	Unit
t <sub>CONV</sub> <sup>(2)</sup>	Total conversion time(including sampling time)	12-bit	—	14	—	1/ f <sub>ADC</sub>
t <sub>SU</sub> <sup>(2)</sup>	Startup time	—	—	—	1	μs

- (1) Based on characterization, not tested in production.  
 (2) Guaranteed by design, not tested in production.

**Table 4-35. ADC characteristics(For GD32F101xC/D/E/F/G//K devices)**

Symbol	Parameter	Conditions	Min	Typ	Max	Unit
V <sub>DDA</sub> <sup>(1)</sup>	Operating voltage	—	2.6	3.3	3.6	V
V <sub>IN</sub> <sup>(1)</sup>	ADC input voltage range	—	0	—	V <sub>REFP</sub>	V
V <sub>REFP</sub> <sup>(2)</sup>	Positive Reference Voltage	—	2.6	—	V <sub>DDA</sub>	V
V <sub>REFN</sub> <sup>(2)</sup>	Negative Reference Voltage	—	—	V <sub>SSA</sub>	—	V
f <sub>ADC</sub> <sup>(1)</sup>	ADC clock	—	0.6	—	14	MHz
f <sub>S</sub> <sup>(1)</sup>	Sampling rate	12-bit	0.04	—	1	MSP S
R <sub>AIN</sub> <sup>(2)</sup>	External input impedance	See <a href="#">Equation 1</a>	—	—	219.8	kΩ
R <sub>ADC</sub> <sup>(2)</sup>	Input sampling switch resistance	—	—	—	0.5	kΩ
C <sub>ADC</sub> <sup>(2)</sup>	Input sampling capacitance	No pin/pad capacitance included	—	—	8	pF
t <sub>CAL</sub> <sup>(2)</sup>	Calibration time	f <sub>ADC</sub> = 14 MHz	—	7.28	—	μs
t <sub>S</sub> <sup>(2)</sup>	Sampling time	f <sub>ADC</sub> = 14 MHz	0.11	—	17.11	μs
t <sub>CONV</sub> <sup>(2)</sup>	Total conversion time(including sampling time)	12-bit	—	14	—	1/ f <sub>ADC</sub>
t <sub>SU</sub> <sup>(2)</sup>	Startup time	—	—	—	1	μs

- (1) Based on characterization, not tested in production.  
 (2) Guaranteed by design, not tested in production.

**Equation 1:** R<sub>AIN max</sub> formula  $R_{AIN} < \frac{T_s}{f_{ADC} * C_{ADC} * \ln(2^{N+2})} - R_{ADC}$

The formula above ([Equation 1](#)) is used to determine the maximum external impedance allowed for an error below 1/4 of LSB. Here N=12 (from 12-bit resolution).

**Table 4-36. ADC R<sub>AIN max</sub> for f<sub>ADC</sub> = 14 MHz(For GD32F101x4/6/8/B devices)**

T <sub>s</sub> (cycles)	t <sub>s</sub> (μs)	R <sub>AIN max</sub> (kΩ)
1.5	0.11	0.1
7.5	0.54	1.5
13.5	0.96	2.9
28.5	2.04	6.3
41.5	2.96	9.3
55.5	3.96	12.5



$T_s$ (cycles)	$t_s$ ( $\mu s$ )	$R_{AIN\ max}$ (k $\Omega$ )
71.5	5.11	16.2
239.5	17.11	54.8

**Table 4-37. ADC  $R_{AIN\ max}$  for  $f_{ADC} = 14\ MHz$  (For GD32F101xC/D/E/F/G/K devices)**

$T_s$ (cycles)	$t_s$ ( $\mu s$ )	$R_{AIN\ max}$ (k $\Omega$ )
1.5	0.11	0.8
7.5	0.54	6.4
13.5	0.96	11.9
28.5	2.04	25.7
41.5	2.96	37.6
55.5	3.96	50.5
71.5	5.11	65.2
239.5	17.11	219.8

#### 4.14. Temperature sensor characteristics

**Table 4-38. Temperature sensor characteristics<sup>(1)</sup>**

Symbol	Parameter	Min	Typ	Max	Unit
$T_L$	VSENSE linearity with temperature	—	$\pm 1.5$	—	$^{\circ}C$
Avg_Slope	Average slope	—	4.1	—	mV/ $^{\circ}C$
$V_{25}$	Voltage at 25 $^{\circ}C$	—	1.45	—	V
$t_{S\_temp}$ <sup>(2)</sup>	ADC sampling time when reading the temperature	—	17.1	—	$\mu s$

(1) Based on characterization, not tested in production.

(2) Shortest sampling time can be determined in the application by multiple iterations.

#### 4.15. I2C characteristics

**Table 4-39. I2C characteristics<sup>(1)(2)</sup>**

Symbol	Parameter	Conditions	Standard mode		Fast mode		Unit
			Min	Max	Min	Max	
$t_{SCL(H)}$	SCL clock high time	—	4.0	—	0.6	—	$\mu s$
$t_{SCL(L)}$	SCL clock low time	—	4.7	—	1.3	—	$\mu s$
$T_{SU(SDA)}$	SDA setup time	—	250	—	100	—	ns
$T_{H(SDA)}$	SDA data hold time	—	0 <sup>(3)</sup>	3450	0	900	ns
$T_{R(SDA/SCL)}$	SDA and SCL rise time	—	—	1000	—	300	ns
$T_{F(SDA/SCL)}$	SDA and SCL fall time	—	—	300	—	300	ns
$T_{H(STA)}$	Start condition hold time	—	4.0	—	0.6	—	$\mu s$
$T_{SU(STA)}$	Repeated Start condition setup time	—	4.7	—	0.6	—	$\mu s$
$T_{SU(STO)}$	Stop condition setup time	—	4.0	—	0.6	—	$\mu s$





Symbol	Parameter	Conditions	Standard mode		Fast mode		Unit
			Min	Max	Min	Max	
T <sub>BUFF</sub>	Stop to Start condition time (bus free)	—	4.7	—	1.3	—	μs

- (1) Guaranteed by design, not tested in production.
- (2) To ensure the standard mode I2C frequency,  $f_{PCLK1}$  must be at least 2 MHz. To ensure the fast mode I2C frequency,  $f_{PCLK1}$  must be at least 4 MHz.
- (3) The device should provide a data hold time of 300 ns at least in order to bridge the undefined region of the falling edge of SCL.

Figure 4-3. I2C bus timing diagram

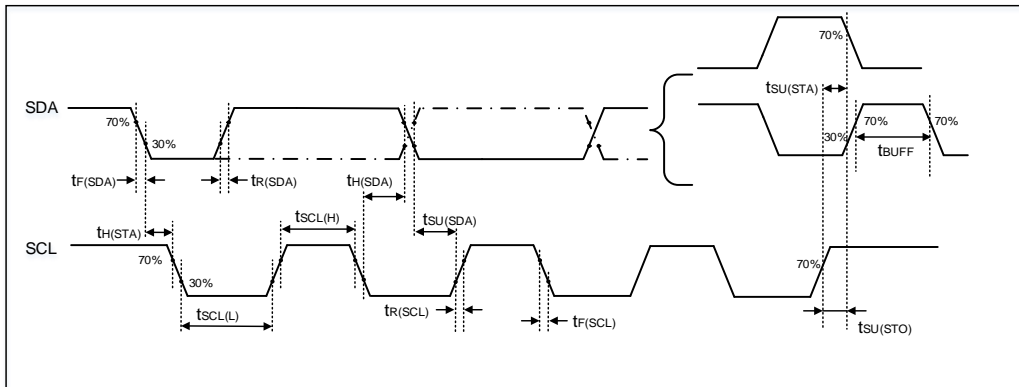

## 4.16. SPI characteristics

Table 4-40. Standard SPI characteristics<sup>(1)</sup>

Symbol	Parameter	Conditions	Min	Typ	Max	Unit
$f_{SCK}$	SCK clock frequency	—	—	—	27	MHz
$t_{SCK(H)}$	SCK clock high time	Master mode, $f_{PCLKx} = 108$ MHz, presc = 4	35.13	37.13	39.13	ns
$t_{SCK(L)}$	SCK clock low time	Master mode, $f_{PCLKx} = 108$ MHz, presc = 4	35.13	37.13	39.13	ns
<b>SPI master mode</b>						
$t_{V(MO)}$	Data output valid time	—	—	—	8	ns
$t_{SU(MI)}$	Data input setup time	—	1	—	—	ns
$t_{H(MI)}$	Data input hold time	—	0	—	—	ns
<b>SPI slave mode</b>						
$t_{SU(NSS)}$	NSS enable setup time	—	0	—	—	ns
$t_{H(NSS)}$	NSS enable hold time	—	1	—	—	ns
$t_{A(SO)}$	Data output access time	—	—	9	—	ns
$t_{DIS(SO)}$	Data output disable time	—	—	11	—	ns
$t_{V(SO)}$	Data output valid time	—	—	11	—	ns
$t_{SU(SI)}$	Data input setup time	—	0	—	—	ns
$t_{H(SI)}$	Data input hold time	—	1	—	—	ns

(1) Based on characterization, not tested in production.

Figure 4-4. SPI timing diagram - master mode

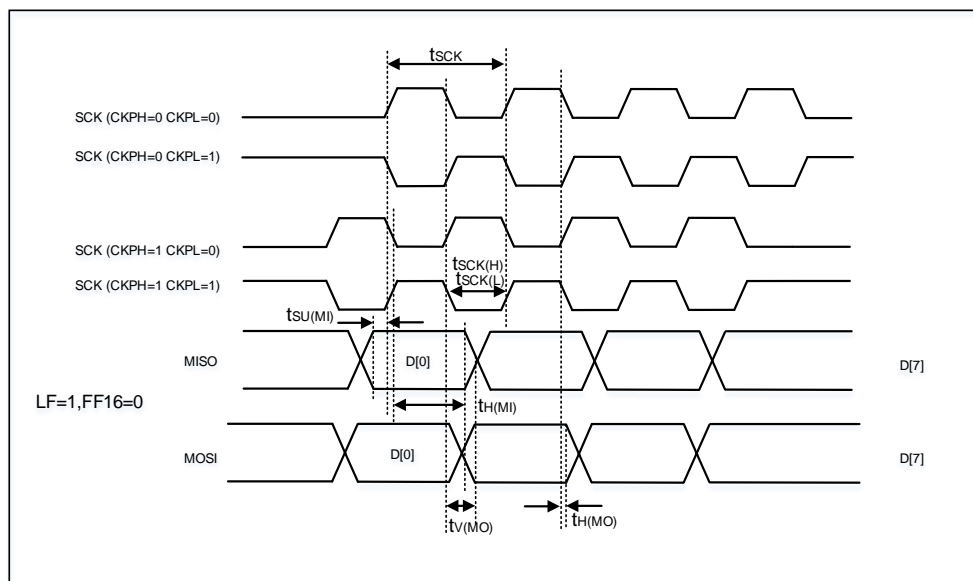
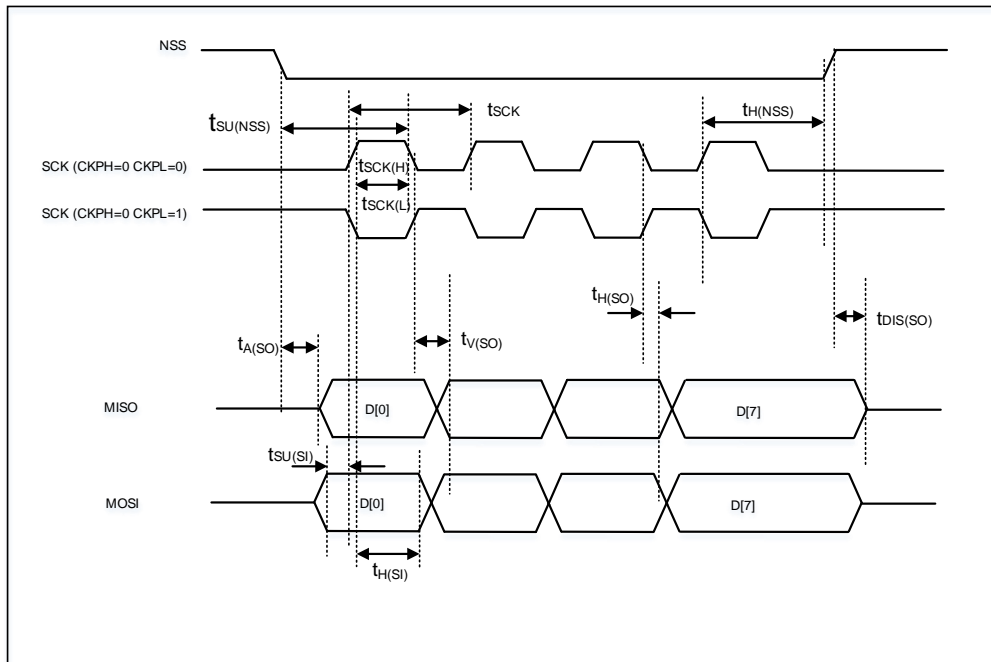

Figure 4-5. SPI timing diagram - slave mode



## 4.17. USART characteristics

Table 4-41. USART characteristics<sup>(1)</sup>

Symbol	Parameter	Conditions	Min	Typ	Max	Unit
$f_{SCK}$	SCK clock frequency	$f_{PCLKx} = 108 \text{ MHz}$	—	—	13.5	MHz
$t_{SCK(H)}$	SCK clock high time	$f_{PCLKx} = 108 \text{ MHz}$	37.0	—	—	ns
$t_{SCK(L)}$	SCK clock low time	$f_{PCLKx} = 108 \text{ MHz}$	37.0	—	—	ns

(1) Guaranteed by design, not tested in production.

## 4.18. TIMER characteristics

**Table 4-42. TIMER characteristics<sup>(1)</sup>**

Symbol	Parameter	Conditions	Min	Max	Unit
$t_{res}$	Timer resolution time	—	1	—	$t_{TIMERxCLK}$
		$f_{TIMERxCLK} = 108 \text{ MHz}$	9.3	—	ns
$f_{EXT}$	Timer external clock frequency	—	0	$f_{TIMERxCLK}/2$	MHz
		$f_{TIMERxCLK} = 108 \text{ MHz}$	0	54	MHz
RES	Timer resolution	—	—	16	bit
$t_{COUNTER}$	16-bit counter clock period when internal clock is selected	—	1	65536	$t_{TIMERxCLK}$
		$f_{TIMERxCLK} = 108 \text{ MHz}$	0.0093	607	$\mu\text{s}$
$t_{MAX\_COUNT}$	Maximum possible count	—	—	$65536 \times 65536$	$t_{TIMERxCLK}$
		$f_{TIMERxCLK} = 108 \text{ MHz}$	—	39.8	s

(1) Guaranteed by design, not tested in production.

## 4.19. WDGT characteristics

**Table 4-43. FWDGT min/max timeout period at 40 kHz (IRC40K)<sup>(1)</sup>**

Prescaler divider	PR[2:0] bits	Min timeout RLD[11:0] = 0x000	Max timeout RLD[11:0] = 0xFFF	Unit
1/4	000	0.025	409.525	ms
1/8	001	0.025	819.025	
1/16	010	0.025	1638.025	
1/32	011	0.025	3276.025	
1/64	100	0.025	6552.025	
1/128	101	0.025	13104.025	
1/256	110 or 111	0.025	26208.025	

(1) Guaranteed by design, not tested in production.

**Table 4-44. WWDGT min-max timeout value at 54 MHz ( $f_{PCLK1}$ )<sup>(1)</sup>**

Prescaler divider	PSC[2:0]	Min timeout value CNT[6:0] = 0x40	Unit	Max timeout value CNT[6:0] = 0x7F	Unit
1/1	00	75.8	$\mu\text{s}$	4.8	ms
1/2	01	151.7		9.7	
1/4	10	303.4		19.4	
1/8	11	606.8		38.8	

(1) Guaranteed by design, not tested in production.

## 4.20. Parameter conditions

Unless otherwise specified, all values given for  $V_{DD} = V_{DDA} = 3.3 \text{ V}$ ,  $T_A = 25 \text{ }^\circ\text{C}$ .





## 5. Package information

### 5.1 LQFP144 package outline dimensions

Figure 5-1. LQFP144 package outline

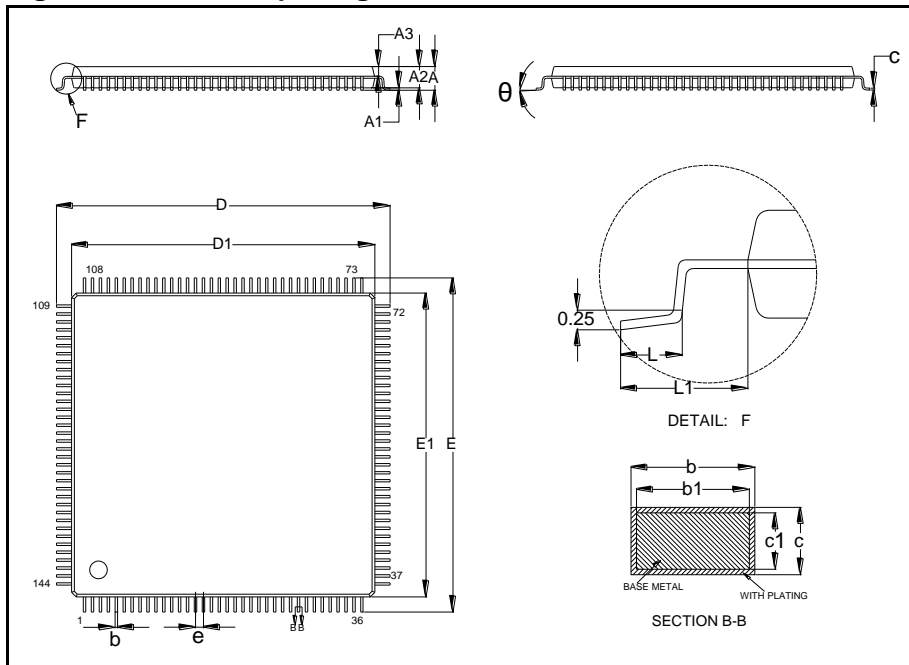
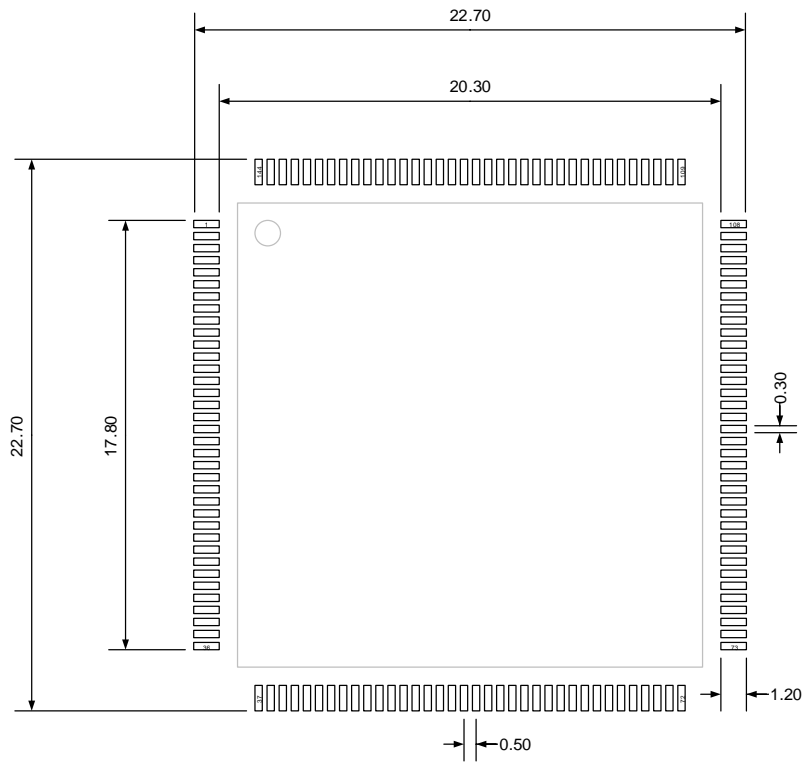

Table 5-1. LQFP144 package dimensions

Symbol	Min	Typ	Max
A	—	—	1.60
A1	0.05	—	0.15
A2	1.35	1.40	1.45
A3	0.59	0.64	0.69
b	0.18	—	0.26
b1	0.17	0.20	0.23
c	0.13	—	0.17
c1	0.12	0.13	0.14
D	21.80	22.00	22.20
D1	19.90	20.00	20.10
E	21.80	22.00	22.20
E1	19.90	20.00	20.10
e	—	0.50	—
L	0.45	—	0.75
L1	—	1.00	—
$\theta$	0°	—	7°

(Original dimensions are in millimeters)

Figure 5-2. LQFP144 recommended footprint



(Original dimensions are in millimeters)

## 5.2 LQFP100 package outline dimensions

Figure 5-3. LQFP100 package outline

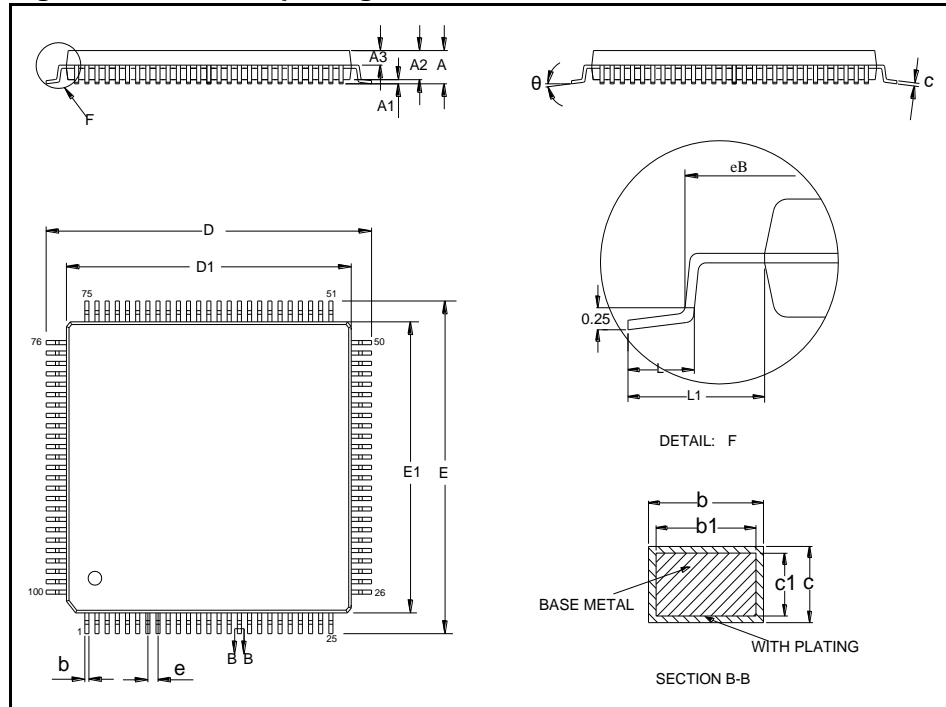

Table 5-2. LQFP100 package dimensions

Symbol	Min	Typ	Max
A	—	—	1.60
A1	0.05	—	0.15
A2	1.35	1.40	1.45
A3	0.59	0.64	0.69
b	0.18	—	0.26
b1	0.17	0.20	0.23
c	0.13	—	0.17
c1	0.12	0.13	0.14
D	15.80	16.00	16.20
D1	13.90	14.00	14.10
E	15.80	16.00	16.20
E1	13.90	14.00	14.10
e	—	0.50	—
eB	15.05	—	15.35
L	0.45	—	0.75
L1	—	1.00	—
θ	0°	—	7°

(Original dimensions are in millimeters)



Figure 5-4. LQFP100 recommended footprint

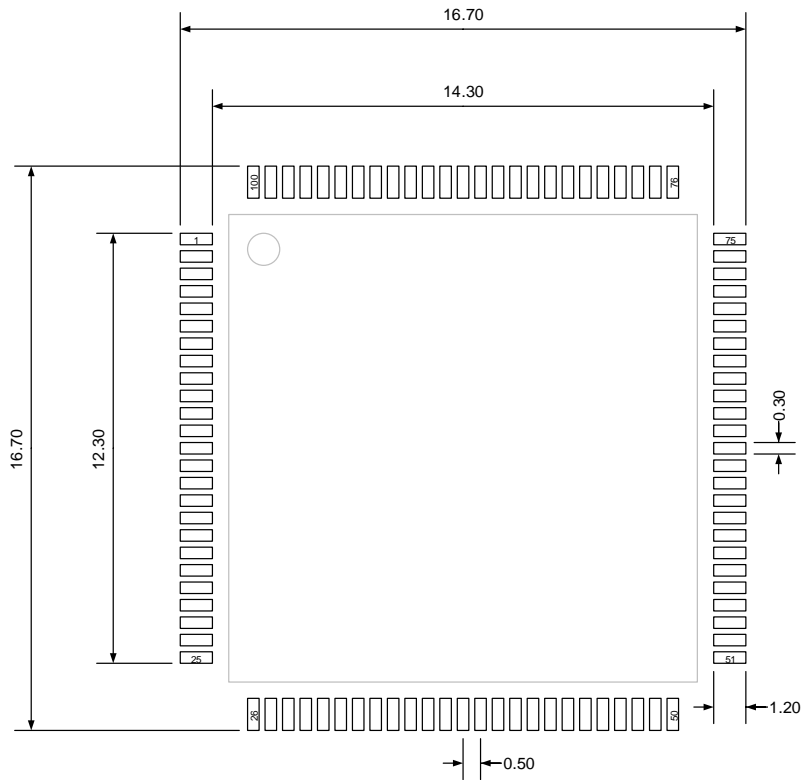

(Original dimensions are in millimeters)

### 5.3 LQFP64 package outline dimensions

Figure 5-5. LQFP64 package outline

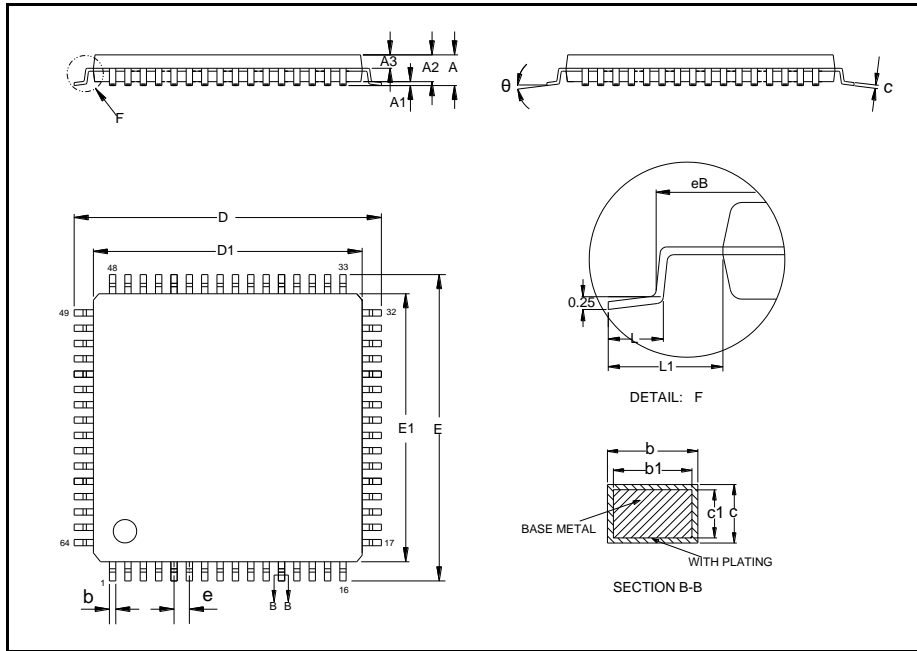
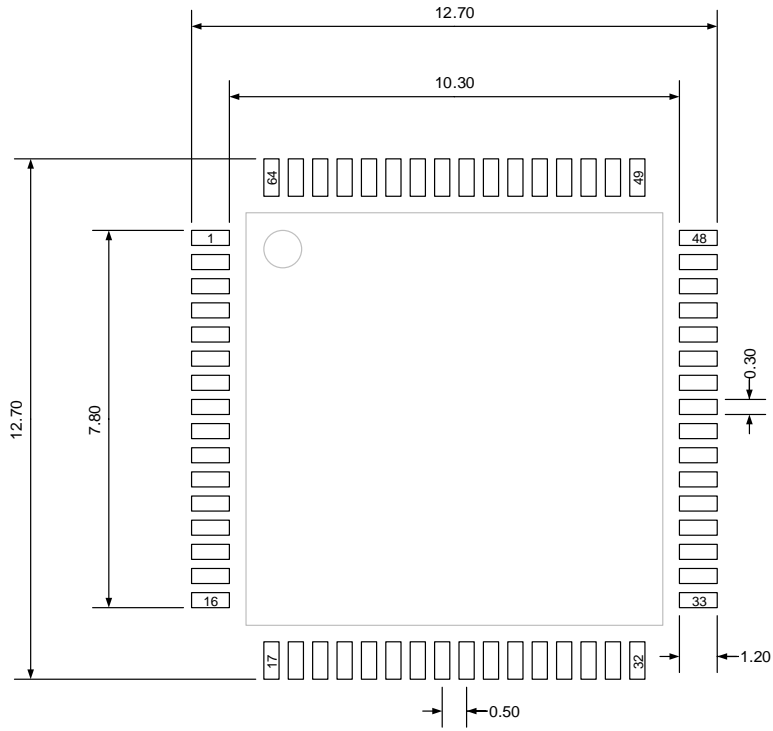

Table 5-3. LQFP64 package dimensions

Symbol	Min	Typ	Max
A	—	—	1.60
A1	0.05	—	0.15
A2	1.35	1.40	1.45
A3	0.59	0.64	0.69
b	0.18	—	0.26
b1	0.17	0.20	0.23
c	0.13	—	0.17
c1	0.12	0.13	0.14
D	11.80	12.00	12.20
D1	9.90	10.00	10.10
E	11.80	12.00	12.20
E1	9.90	10.00	10.10
e	—	0.50	—
eB	11.25	—	11.45
L	0.45	—	0.75
L1	—	1.00	—
$\theta$	0°	—	7°

(Original dimensions are in millimeters)

Figure 5-6. LQFP64 recommended footprint



(Original dimensions are in millimeters)

## 5.4 LQFP48 package outline dimensions

Figure 5-7. LQFP48 package outline

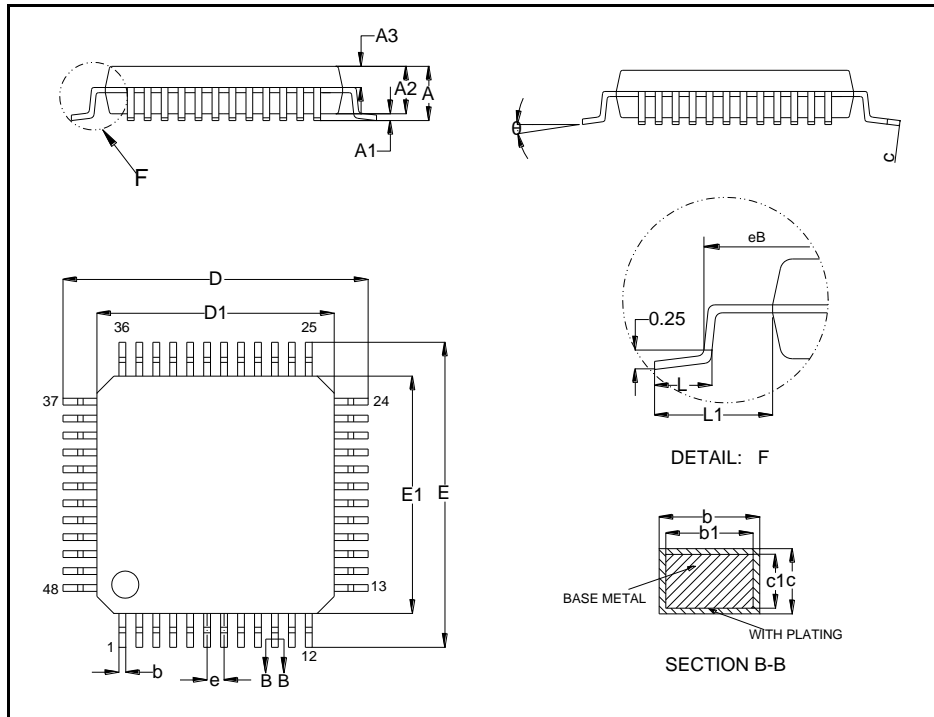
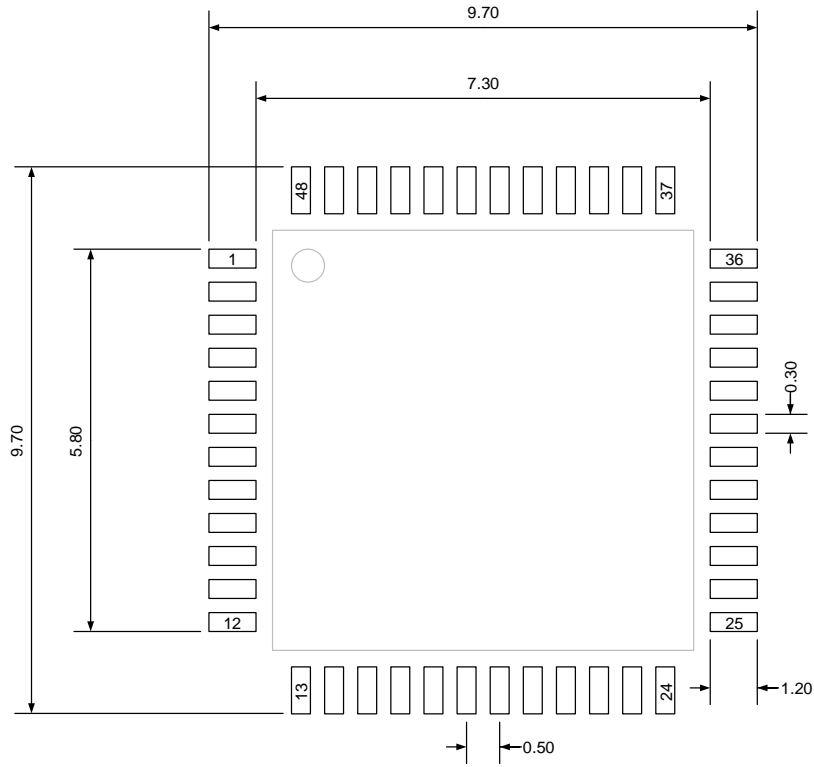

Table 5-4. LQFP48 package dimensions

Symbol	Min	Typ	Max
A	—	—	1.60
A1	0.05	—	0.15
A2	1.35	1.40	1.45
A3	0.59	0.64	0.69
b	0.18	—	0.26
b1	0.17	0.20	0.23
c	0.13	—	0.17
c1	0.12	0.13	0.14
D	8.80	9.00	9.20
D1	6.90	7.00	7.10
E	8.80	9.00	9.20
E1	6.90	7.00	7.10
e	—	0.50	—
eB	8.10	—	8.25
L	0.45	—	0.75
L1	—	1.00	—
$\theta$	0°	—	7°

(Original dimensions are in millimeters)

Figure 5-8. LQFP48 recommended footprint



(Original dimensions are in millimeters)

## 5.5 QFN36 package outline dimensions

Figure 5-9. QFN36 package outline

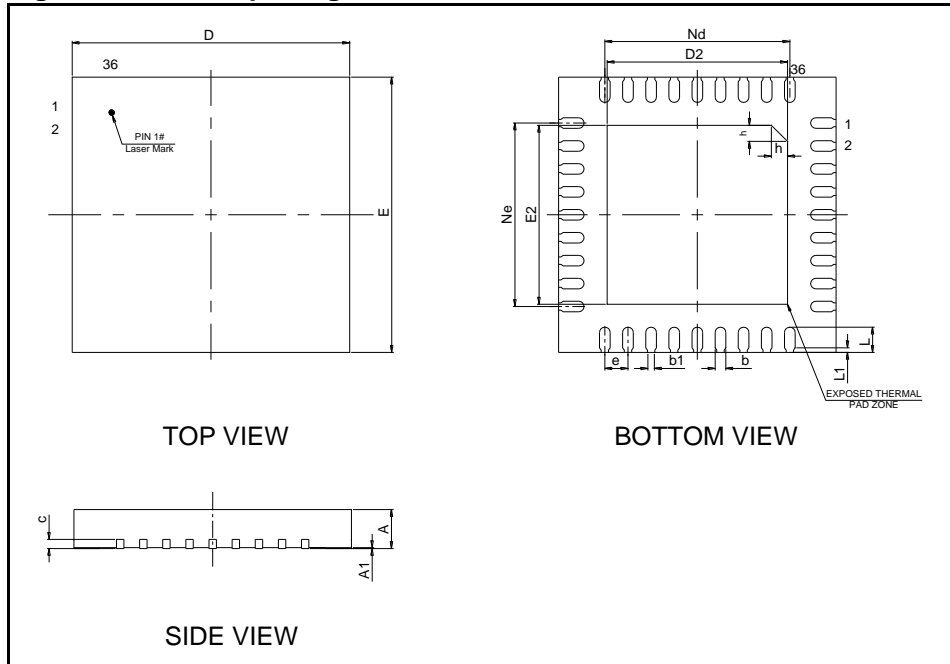
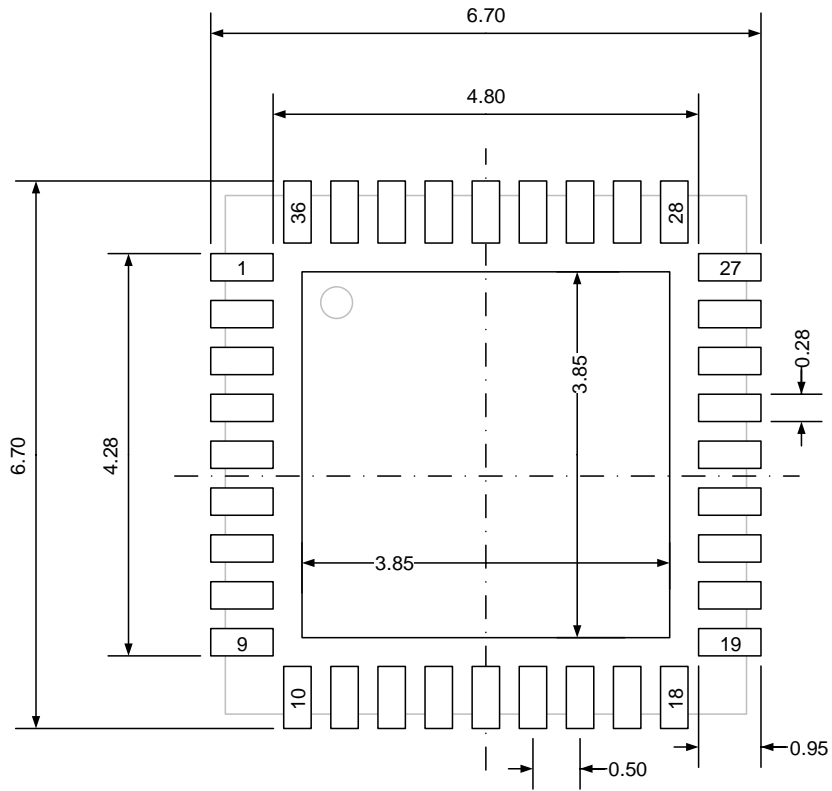

Table 5-5. QFN36 package dimensions

Symbol	Min	Typ	Max
A	0.80	0.85	0.90
A1	0	0.02	0.05
b	0.18	0.23	0.30
b1	—	0.16	—
c	0.18	0.20	0.23
D	5.90	6.00	6.10
D2	3.80	3.90	4.00
E	5.90	6.00	6.10
E2	3.80	3.90	4.00
e	—	0.50	—
h	0.30	0.35	0.40
L	0.50	0.55	0.60
L1	—	0.10	—
Nd	3.95	4.00	4.05
Ne	3.95	4.00	4.05

(Original dimensions are in millimeters)

Figure 5-10. QFN36 recommended footprint



(Original dimensions are in millimeters)

## 5.6 Thermal characteristics

Thermal resistance is used to characterize the thermal performance of the package device, which is represented by the Greek letter “ $\theta$ ”. For semiconductor devices, thermal resistance represents the steady-state temperature rise of the chip junction due to the heat dissipated on the chip surface.

$\theta_{JA}$ : Thermal resistance, junction-to-ambient.

$\theta_{JB}$ : Thermal resistance, junction-to-board.

$\theta_{JC}$ : Thermal resistance, junction-to-case.

$\Psi_{JB}$ : Thermal characterization parameter, junction-to-board.

$\Psi_{JT}$ : Thermal characterization parameter, junction-to-top center.

$$\theta_{JA} = (T_J - T_A) / P_D \quad (5-1)$$

$$\theta_{JB} = (T_J - T_B) / P_D \quad (5-2)$$

$$\theta_{JC} = (T_J - T_C) / P_D \quad (5-3)$$

Where,  $T_J$  = Junction temperature.

$T_A$  = Ambient temperature

$T_B$  = Board temperature

$T_C$  = Case temperature which is monitoring on package surface

$P_D$  = Total power dissipation

$\theta_{JA}$  represents the resistance of the heat flows from the heating junction to ambient air. It is an indicator of package heat dissipation capability. Lower  $\theta_{JA}$  can be considerate as better overall thermal performance.  $\theta_{JA}$  is generally used to estimate junction temperature.

$\theta_{JB}$  is used to measure the heat flow resistance between the chip surface and the PCB board.

$\theta_{JC}$  represents the thermal resistance between the chip surface and the package top case.  $\theta_{JC}$  is mainly used to estimate the heat dissipation of the system (using heat sink or other heat dissipation methods outside the device package).

**Table 5-6. Package thermal characteristics<sup>(1)</sup>**

Symbol	Condition	Package	Value	Unit
$\theta_{JA}$	Natural convection, 2S2P PCB	LQFP144	48.76	°C/W
		LQFP100	57.42	
		LQFP64	61.80	
		LQFP48	64.40	
		QFN36	43.20	
$\theta_{JB}$	Cold plate, 2S2P PCB	LQFP144	35.00	°C/W





Symbol	Condition	Package	Value	Unit
		LQFP100	31.68	
		LQFP64	42.83	
		LQFP48	42.32	
		QFN36	16.51	
$\theta_{JC}$	Cold plate, 2S2P PCB	LQFP144	12.03	°C/W
		LQFP100	13.85	
		LQFP64	21.98	
		LQFP48	22.47	
		QFN36	16.18	
$\Psi_{JB}$	Natural convection, 2S2P PCB	LQFP144	35.32	°C/W
		LQFP100	41.28	
		LQFP64	43.05	
		LQFP48	42.42	
		QFN36	16.64	
$\Psi_{JT}$	Natural convection, 2S2P PCB	LQFP144	1.86	°C/W
		LQFP100	0.75	
		LQFP64	1.58	
		LQFP48	1.74	
		QFN36	1.07	

(1) Thermal characteristics are based on simulation, and meet JEDEC specification.



## 5. Ordering information

**Table 5-1. Part ordering code for GD32F101xx devices**

Ordering code	Flash (KB)	Package	Package type	Temperature operating range
GD32F101ZKT6	3072	LQFP144	Green	Industrial -40°C to +85°C
GD32F101ZIT6	2048	LQFP144	Green	Industrial -40°C to +85°C
GD32F101ZGT6	1024	LQFP144	Green	Industrial -40°C to +85°C
GD32F101ZFT6	768	LQFP144	Green	Industrial -40°C to +85°C
GD32F101ZET6	512	LQFP144	Green	Industrial -40°C to +85°C
GD32F101ZDT6	384	LQFP144	Green	Industrial -40°C to +85°C
GD32F101ZCT6	256	LQFP144	Green	Industrial -40°C to +85°C
GD32F101VKT6	3072	LQFP100	Green	Industrial -40°C to +85°C
GD32F101VIT6	2048	LQFP100	Green	Industrial -40°C to +85°C
GD32F101VGT6	1024	LQFP100	Green	Industrial -40°C to +85°C
GD32F101VFT6	768	LQFP100	Green	Industrial -40°C to +85°C
GD32F101VET6	512	LQFP100	Green	Industrial -40°C to +85°C
GD32F101VDT6	384	LQFP100	Green	Industrial -40°C to +85°C
GD32F101RDT6	384	LQFP64	Green	Industrial -40°C to +85°C
GD32F101RET6	512	LQFP64	Green	Industrial -40°C to +85°C
GD32F101VCT6	256	LQFP100	Green	Industrial -40°C to +85°C
GD32F101VBT6	128	LQFP100	Green	Industrial -40°C to +85°C
GD32F101V8T6	64	LQFP100	Green	Industrial -40°C to +85°C
GD32F101RKT6	3072	LQFP64	Green	Industrial -40°C to +85°C
GD32F101RIT6	2048	LQFP64	Green	Industrial -40°C to +85°C
GD32F101RGT6	1024	LQFP64	Green	Industrial -40°C to +85°C
GD32F101RFT6	768	LQFP64	Green	Industrial -40°C to +85°C
GD32F101RCT6	256	LQFP64	Green	Industrial -40°C to +85°C
GD32F101RBT6	128	LQFP64	Green	Industrial -40°C to +85°C



Ordering code	Flash (KB)	Package	Package type	Temperature operating range
GD32F101R8T6	64	LQFP64	Green	Industrial -40°C to +85°C
GD32F101R6T6	32	LQFP64	Green	Industrial -40°C to +85°C
GD32F101R4T6	16	LQFP64	Green	Industrial -40°C to +85°C
GD32F101CBT6	128	LQFP48	Green	Industrial -40°C to +85°C
GD32F101C8T6	64	LQFP48	Green	Industrial -40°C to +85°C
GD32F101C6T6	32	LQFP48	Green	Industrial -40°C to +85°C
GD32F101C4T6	16	LQFP48	Green	Industrial -40°C to +85°C
GD32F101TBU6	128	QFN36	Green	Industrial -40°C to +85°C
GD32F101T8U6	64	QFN36	Green	Industrial -40°C to +85°C
GD32F101T6U6	32	QFN36	Green	Industrial -40°C to +85°C
GD32F101T4U6	16	QFN36	Green	Industrial -40°C to +85°C

## 6. Revision history

Table 6-1. Revision history

Revision No.	Description	Date
1.0	Initial Release	Jun.2, 2013
2.0	1. Characteristics values modified and package data updated, refers to <b><u>Electrical characteristics</u></b> and <b><u>Package information</u></b> .	Nov.15, 2013
2.1	1. Characteristics values modified, refers to <b><u>Electrical characteristics</u></b> .	Aug.18, 2014
2.2	1. Repair history accumulation error.	Jan.24, 2018
2.3	1. Delete the PD0,PD1 remap to OSC pins information in packages no less than 100 pins, refers to <b><u>Pin definitions</u></b> .	Feb.15, 2020
2.4	1. Integrate the boot loader address in chapter 2.4 together, refers to <b><u>Memory map</u></b> . 2. Add description of V <sub>REFP</sub> and V <sub>REFN</sub> connection in chapter 3.6, refers to <b><u>Analog to digital converter (ADC)</u></b> . 3. Arm® Cortex® w ritten format modification.	Sep.18, 2020
2.5	1. Maximum supply current in deep-sleep mode modification, refers to <b><u>Table 4-3. Power consumption characteristics</u></b> . 2. Table 4-3 update, refers to <b><u>Table 4-3. Power consumption characteristics</u></b> .	Apr.12, 2021
2.6	1. Delete PD0 / PD1 from OSCIN / OSCOUT remap information in chapter 2.6.3 to 2.6.5, ETM related functions modification in chapter 2.6.2 to 2.6.5, refers to <b><u>Pin definitions</u></b> . 2. Modify pinouts, refers to <b><u>Pinouts and pin assignment</u></b> . 3. Characteristics values modified and updated, refers to <b><u>Electrical characteristics</u></b> . 4. Package information and Ordering information update, refer to <b><u>Package information</u></b> and <b><u>Ordering information</u></b> . 5. Modify the notes under <b><u>Table 4-1. Absolute maximum ratings<sup>(1)(4)</sup></u></b> . 6. Modify Vesd (HBM) and Vesd (CDM) standards, refers to <b><u>Electrical characteristics</u></b> . 7. Modify WDG_T characteristics, refers to <b><u>WDGT characteristics</u></b> . 8. Modify SPI/I2S diagrams, refer to <b><u>SPI characteristics</u></b> .	Jun.30, 2022



	<p>and <b><u>I2S characteristics</u></b>.</p> <p>9. Modify I2C characteristics, refer to <b><u>I2C characteristics</u></b>.</p> <p>10. Modify LQFP64 package information, refer to <b><u>LQFP64 package outline dimensions</u></b>.</p> <p>11. Update NRST external pin circuit, refer to <b><u>Figure 4-2. Recommended external NRST pin circuit<sup>(1)</sup></u></b>.</p> <p>12. EXMC related pin update, refer to <b><u>Pin definitions</u></b>.</p>	
2.7	<p>1. Modify gm value in table <b><u>Table 4-19. Low speed external clock (LXTAL) generated from a crystal/ceramic characteristics(For GD32F101x4/6/8/B devices)</u></b> and <b><u>Table 4-20. Low speed external clock (LXTAL) generated from a crystal/ceramic characteristics(For GD32F101xC/D/E/F/G//K devices)</u></b>.</p>	Sep.13, 2022
2.8	<p>1. Format modification.</p> <p>2. Pin name modification in <b><u>Pin definitions</u></b> and <b><u>Pinouts and pin assignment</u></b>.</p> <p>3. Add comments to <b><u>Power consumption</u></b>.</p> <p>4. Modify <b><u>I2C characteristics</u></b> diagram <b><u>Figure 4-3. I2C bus timing diagram</u></b>.</p>	Dec.6, 2022
2.9	<p>1. Format modification: VREFP / VREFN / VDD / VDDA / VSS.</p> <p>2. Modify <b><u>I2C characteristics</u></b> diagram <b><u>Figure 4-3. I2C bus timing diagram</u></b>.</p> <p>3. Add version number and date to cover.</p> <p>4. Add chip type in pin definitions table <b><u>Table 2.5. GD32F101Zx LQFP144 pin definitions/ Table 2.6. GD32F101Vx LQFP100 pin definitions/ Table 2.7. GD32F101Rx LQFP64 pin definitions/ Table 2.8. GD32F101Cx LQFP48 pin definitions/ Table 2.9. GD32F101Tx QFN36 pin definitions</u></b>.</p>	Jun.20, 2023

## Important Notice

This document is the property of GigaDevice Semiconductor Inc. and its subsidiaries (the "Company"). This document, including any product of the Company described in this document (the "Product"), is owned by the Company under the intellectual property laws and treaties of the People's Republic of China and other jurisdictions worldwide. The Company reserves all rights under such laws and treaties and does not grant any license under its patents, copyrights, trademarks, or other intellectual property rights. The names and brands of third party referred thereto (if any) are the property of their respective owner and referred to for identification purposes only.

The Company makes no warranty of any kind, express or implied, with regard to this document or any Product, including, but not limited to, the implied warranties of merchantability and fitness for a particular purpose. The Company does not assume any liability arising out of the application or use of any Product described in this document. Any information provided in this document is provided only for reference purposes. It is the responsibility of the user of this document to properly design, program, and test the functionality and safety of any application made of this information and any resulting product. Except for customized products which has been expressly identified in the applicable agreement, the Products are designed, developed, and/or manufactured for ordinary business, industrial, personal, and/or household applications only. The Products are not designed, intended, or authorized for use as components in systems designed or intended for the operation of weapons, weapons systems, nuclear installations, atomic energy control instruments, combustion control instruments, airplane or spaceship instruments, transportation instruments, traffic signal instruments, life-support devices or systems, other medical devices or systems (including resuscitation equipment and surgical implants), pollution control or hazardous substances management, or other uses where the failure of the device or Product could cause personal injury, death, property or environmental damage ("Unintended Uses"). Customers shall take any and all actions to ensure using and selling the Products in accordance with the applicable laws and regulations. The Company is not liable, in whole or in part, and customers shall and hereby do release the Company as well as its suppliers and/or distributors from any claim, damage, or other liability arising from or related to all Unintended Uses of the Products. Customers shall indemnify and hold the Company as well as its suppliers and/or distributors harmless from and against all claims, costs, damages, and other liabilities, including claims for personal injury or death, arising from or related to any Unintended Uses of the Products.

Information in this document is provided solely in connection with the Products. The Company reserves the right to make changes, corrections, modifications or improvements to this document and Products and services described herein at any time, without notice.