

EN25QW16A (2P)

16 Megabit wide voltage Serial Flash Memory with 4Kbyte Uniform Sector

FEATURES

- Single power supply operation
 - Full voltage range: 1.65-3.6 volt
- Serial Interface Architecture
 - SPI Compatible: Mode 0 and Mode 3
- 16 M-bit Serial Flash
 - 16 M-bit / 2048 KByte / 8192 pages
 - 256 bytes per programmable page
- Standard, Dual or Quad SPI
 - Standard SPI: CLK, CS#, DI, DO, WP#, HOLD#
 - Dual SPI: CLK, CS#, DQ₀, DQ₁, WP#, HOLD#
 - Quad SPI: CLK, CS#, DQ₀, DQ₁, DQ₂, DQ₃
 - Configurable dummy cycle number
- High performance
 - 104 MHz clock rate for Standard SPI
 - 104 MHz clock rate for two data bits
 - 104 MHz clock rate for four data bits
- Low power consumption
 - 10 mA typical active current
 - 1 μ A typical power down current
- Uniform Sector Architecture
 - 512 sectors of 4-Kbyte
 - 64 blocks of 32-Kbyte
 - 32 blocks of 64-Kbyte
 - Any sector or block can be erased individually
- Software and Hardware Write Protection
 - Write Protect all or portion of memory via software
 - Enable/Disable protection with WP# pin
- High performance program/erase speed
 - Page program time: 1 ms typical
 - Sector erase time: 100 ms typical
 - Half Block erase time: 300 ms typical
 - Block erase time: 500 ms typical
 - Chip erase time: 15 seconds typical
- Write Suspend and Write Resume
- Volatile Status Register Bits
- Lockable 3x1024 byte OTP security sector
- Support Serial Flash Discoverable Parameters (SFDP) signature
- Read Unique ID Number
- Minimum 100K endurance cycle
- Data retention time 20 years
- Package Options
 - 8-pin SOP 150 mil body width
 - 8-pin SOP 200 mil body width
 - 8-contact VDFN / WSON (6x5 mm)
 - All Pb-free packages are compliant RoHS, Halogen-Free and REACH
- Industrial temperature Range

GENERAL DESCRIPTION

The device is a 16 Megabit (2048K-byte) Serial Flash memory, with advanced write protection mechanisms. The device supports the single bit and four bits serial input and output commands via standard Serial Peripheral Interface (SPI) pins: Serial Clock, Chip Select, Serial DQ₀ (DI) and DQ₁ (DO), DQ₂ (WP#) and DQ₃ (HOLD#). The memory can be programmed 1 to 256 bytes at a time, using the Page Program instruction.

The device also offers a sophisticated method for protecting individual blocks against erroneous or malicious program and erase operations. By providing the ability to individually protect and unprotect blocks, a system can unprotect a specific block to modify its contents while keeping the remaining blocks of the memory array securely protected. This is useful in applications where program code is patched or updated on a subroutine or module basis or in applications where data storage segments need to be modified without running the risk of errant modifications to the program code segments.

The device is designed to allow either single Sector/Block at a time or full chip erase operation. The device can be configured to protect part of the memory as the software protected mode. The device can sustain a minimum of 100K program/erase cycles on each sector or block.

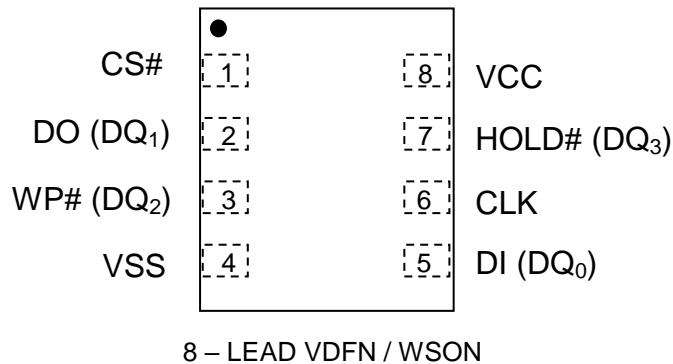
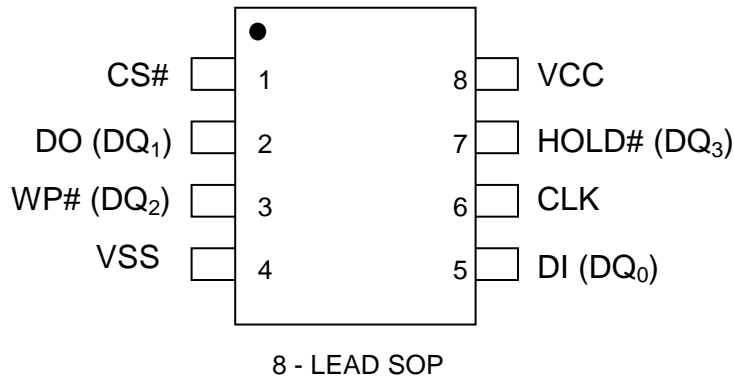
CONNECTION DIAGRAMS (TOP VIEW)

Pin Names

Symbol	Pin Name
CLK	Serial Clock Input
DI (DQ ₀)	Serial Data Input (Data Input Output 0) ^{*1}
DO (DQ ₁)	Serial Data Output (Data Input Output 1) ^{*1}
CS#	Chip Enable
WP# (DQ ₂)	Write Protect (Data Input Output 2) ^{*2}
HOLD# (DQ ₃)	HOLD# pin (Data Input Output 3) ^{*2}
V _{CC}	Supply Voltage (1.65-3.6V)
V _{SS}	Ground
NC	No Connect

Note:

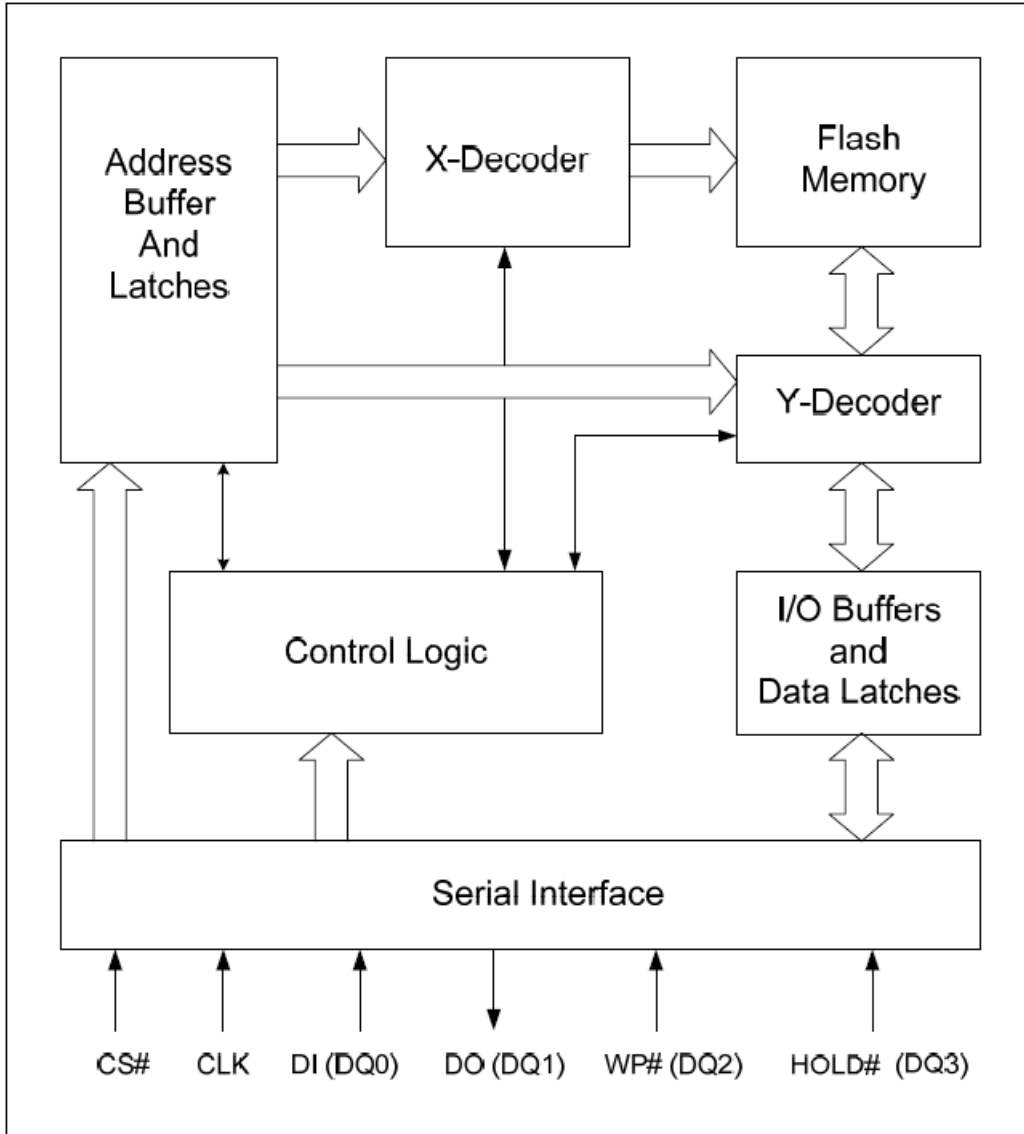
- DQ₀ and DQ₁ are used for Dual and Quad instructions.
- DQ₀ ~ DQ₃ are used for Quad instructions.
WP# & HOLD# functions are only available for Standard/Dual SPI.

BLOCK DIAGRAM

Note:

1. DQ₀ and DQ₁ are used for Dual instructions.
2. DQ₀ ~ DQ₃ are used for Quad instructions.

SIGNAL DESCRIPTION

Serial Data Input, Output and IOs (DI, DO and DQ₀, DQ₁, DQ₂, DQ₃)

The device support standard SPI, Dual SPI and Quad SPI operation. Standard SPI instructions use the unidirectional DI (input) pin to serially write instructions, addresses or data to the device on the rising edge of the Serial Clock (CLK) input pin. Standard SPI also uses the unidirectional DO (output) to read data or status from the device on the falling edge CLK.

Dual and Quad SPI instruction use the bidirectional IO pins to serially write instruction, addresses or data to the device on the rising edge of CLK and read data or status from the device on the falling edge of CLK.

Serial Clock (CLK)

The SPI Serial Clock Input (CLK) pin provides the timing for serial input and output operations. ("See SPI Mode")

Chip Select (CS#)

The SPI Chip Select (CS#) pin enables and disables device operation. When CS# is high the device is deselected and the Serial Data Output (DO, or DQ₀, DQ₁, DQ₂ and DQ₃) pins are at high impedance. When deselected, the devices power consumption will be at standby levels unless an internal erase, program or status register cycle is in progress. When CS# is brought low the device will be selected, power consumption will increase to active levels and instructions can be written to and data read from the device. After power-up, CS# must transition from high to low before a new instruction will be accepted.

Write Protect (WP#)

The Write Protect (WP#) pin can be used to prevent the Status Register from being written. Used in conjunction with the Status Register's Block Protect (4KBL, TB, BP2, BP1 and BP0) bits and Status Register Protect (SRP and SRP1) bits, a portion or the entire memory array can be hardware protected. The WP# function is only available for standard SPI and Dual SPI operation, when during Quad SPI, this pin is the Serial Data IO (DQ₂) for Quad I/O operation.

HOLD (HOLD#)

The HOLD# pin allows the device to be paused while it is actively selected. When QE bit is "0" (factory default), the HOLD# pin is enabled. When HOLD# is brought low, while CS# is low, the DO pin will be at high impedance and signals on the DI and CLK pins will be ignored (don't care). The hold function can be useful when multiple devices are sharing the same SPI signals. The HOLD# function is only available for standard SPI and Dual SPI operation, when during Quad SPI, this pin is the Serial Data IO (DQ₃) for Quad I/O operation

MEMORY ORGANIZATION

The memory is organized as:

- 2,097,152 bytes
- Uniform Sector Architecture
 - 32 blocks of 64-Kbyte
 - 64 sectors of 32-Kbyte
 - 512 sectors of 4-Kbyte
 - 8192 pages (256 bytes each)

Each page can be individually programmed (bits are programmed from 1 to 0). The device is Sector, Block or Chip Erasable but not Page Erasable.

Uniform Block Sector Architecture

64KB Block	32KB Block	Sector	Address range	
31	63	511	01FF000h	01FFFFFFh
	62	⋮	⋮	⋮
30		61	496	01F0000h
	60	495	01EF000h	01EFFFFh
29		59	480	01E0000h
	58	479	01DF000h	01DFFFFh
18		37	464	01D0000h
	36	303	012F000h	012FFFFh
17		35	288	0120000h
	34	287	011F000h	011FFFFh
16		33	272	0110000h
	32	271	010F000h	010FFFFh
		256	0100000h	0100FFFFh

64KB Block	32KB Block	Sector	Address range	
15	31	255	00FF000h	00FFFFFFh
	30	240	00F0000h	00F0FFFFh
14		29	239	00EF000h
	28	224	00E0000h	00E0FFFFh
13		27	223	00DF000h
	26	208	00D0000h	00D0FFFFh
2		5	47	002F000h
	4	32	0020000h	0020FFFFh
1		3	31	001F000h
	2	16	0010000h	0010FFFFh
0		1	15	000F000h
	0	0	0	0000000h

OPERATING FEATURES

Standard SPI Modes

The device is accessed through an SPI compatible bus consisting of four signals: Serial Clock (CLK), Chip Select (CS#), Serial Data Input (DI) and Serial Data Output (DO). Both SPI bus operation Modes 0 (0, 0) and 3 (1, 1) are supported. The primary difference between Mode 0 and Mode 3, as shown in SPI Modes figure, concerns the normal state of the CLK signal when the SPI bus master is in standby and data is not being transferred to the Serial Flash. For Mode 0 the CLK signal is normally low. For Mode 3 the CLK signal is normally high. In either case data input on the DI pin is sampled on the rising edge of the CLK. Data output on the DO pin is clocked out on the falling edge of CLK.

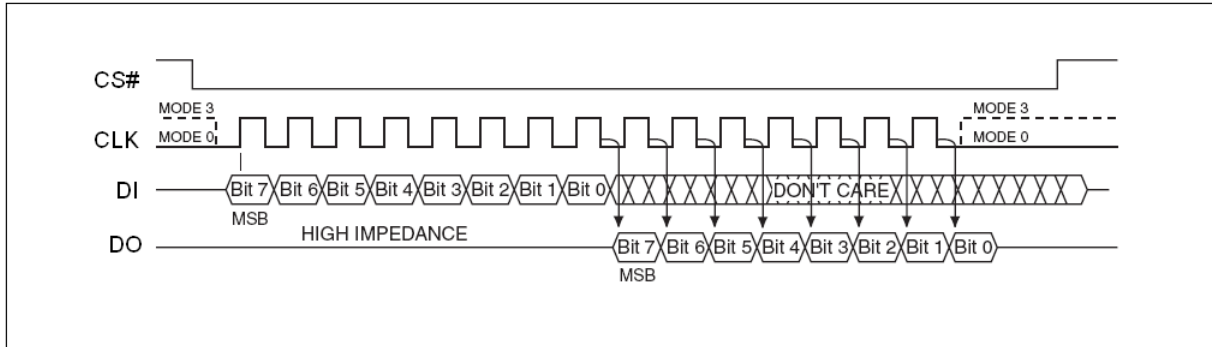

SPI Modes

Dual SPI Instruction

The device supports Dual SPI operation when using the “Dual Output Fast Read and Dual I/ O FAST_READ” (3Bh and BBh) instructions. These instructions allow data to be transferred to or from the Serial Flash memory at two to three times the rate possible with the standard SPI. The Dual Read instructions are ideal for quickly downloading code from Flash to RAM upon power-up (code-shadowing) or for application that cache code-segments to RAM for execution. The Dual output feature simply allows the SPI input pin to also serve as an output during this instruction. When using Dual SPI instructions the DI and DO pins become bidirectional I/O pins; DQ₀ and DQ₁. All other operations use the standard SPI interface with single output signal.

Quad I/O SPI Modes

The device supports Quad output operation when using the Quad I/O Fast Read (EBh). This instruction allows data to be transferred to or from the Serial Flash memory at four to six times the rate possible with the standard SPI. The Quad Read instruction offer a significant improvement in continuous and random access transfer rates allowing fast code-shadowing to RAM or for application that cache code-segments to RAM for execution.

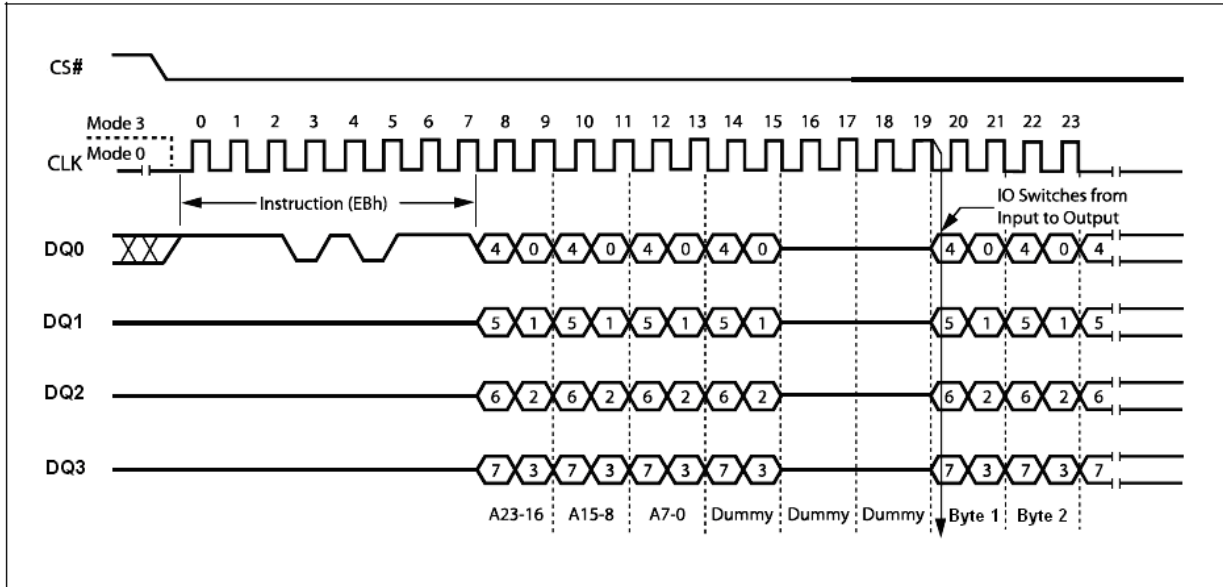

Quad I/O SPI Modes

Page Programming

To program one data byte, two instructions are required: Write Enable (WREN), which is one byte, and a Page Program (PP) or Quad Input Page Program (QPP) sequence, which consists of four bytes plus data. This is followed by the internal Program cycle (of duration t_{PP}).

To spread this overhead, the Page Program (PP) or Quad Input Page Program (QPP) instruction allows up to 256 bytes to be programmed at a time (changing bits from 1 to 0) provided that they lie in consecutive addresses on the same page of memory.

Sector Erase, Half Block Erase, Block Erase and Chip Erase

The Page Program (PP) or Quad Input Page Program (QPP) instruction allows bits to be reset from 1 to 0. Before this can be applied, the bytes of memory need to have been erased to all 1s (FFh). This can be achieved a sector at a time, using the Sector Erase (SE) instruction, half a block at a time using the Half Block Erase (HBE) instruction, a block at a time using the Block Erase (BE) instruction or throughout the entire memory, using the Chip Erase (CE) instruction. This starts an internal Erase cycle (of duration t_{SE} , t_{HBE} , t_{BE} or t_{CE}). The Erase instruction must be preceded by a Write Enable (WREN) instruction.

Polling During a Write, Program or Erase Cycle

A further improvement in the time to Write Status Register (WRSR, WRSR2, WRSR3), Program (PP, QPP) or Erase (SE, HBE, BE or CE) can be achieved by not waiting for the worst case delay (t_W , t_{PP} , t_{SE} , t_{HBE} , t_{BE} or t_{CE}). The Write in Progress (WIP) bit is provided in the Status Register so that the application program can monitor its value, polling it to establish when the previous Write cycle, Program cycle or Erase cycle is complete.

Active Power, Stand-by Power and Deep Power-Down Modes

When Chip Select (CS#) is Low, the device is enabled, and in the Active Power mode. When Chip Select (CS#) is High, the device is disabled, but could remain in the Active Power mode until all internal cycles have completed (Program, Erase, Write Status Register). The device then goes into the Stand-by Power mode. The device consumption drops to I_{CC1} .

The Deep Power-down mode is entered when the specific instruction (the Enter Deep Power-down Mode (DP) instruction) is executed. The device consumption drops further to I_{CC2} . The device remains in this mode until another specific instruction (the Release from Deep Power-down Mode and Read Device ID (RDI) instruction) is executed.

All other instructions are ignored while the device is in the Deep Power-down mode. This can be used as an extra software protection mechanism, when the device is not in active use, to protect the device from inadvertent Write, Program or Erase instructions.

Write Protection

Applications that use non-volatile memory must take into consideration the possibility of noise and other adverse system conditions that may compromise data integrity. To address this concern, the device provides the following data protection mechanisms:

- Power-On Reset and an internal timer (t_{PUW}) can provide protection against inadvertent changes while the power supply is outside the operating specification.
- Program, Erase and Write Status Register instructions are checked that they consist of a number of clock pulses that is a multiple of eight, before they are accepted for execution.
- All instructions that modify data must be preceded by a Write Enable (WREN) instruction to set the Write Enable Latch (WEL) bit. This bit is returned to its reset state by the following events:
 - Power-up
 - Write Disable (WRDI) instruction completion or Write Status Register (WRSR) instruction completion, Write Status Register 2 (WRSR2) instruction completion or Write Status Register 3 (WRSR3) instruction completion or Page Program (PP) or Quad Input Page Program (QPP) instruction completion or Sector Erase (SE) instruction completion or Half Block Erase (HBE) / Block Erase (BE) instruction completion or Chip Erase (CE) instruction completion
- The Block Protect (CMP, 4KBL, TB, BP2, BP1, BP0) bits allow part of the memory to be configured as read-only. This is the Software Protected Mode (SPM).
- The Write Protect (WP#) signal allows the Block Protect (CMP, 4KBL, TB, BP2, BP1, BP0) bits and Status Register Protect (SRP and SRP1) bit to be protected. This is the Hardware Protected Mode (HPM).
- In addition to the low power consumption feature, the Deep Power-down mode offers extra software protection from inadvertent Write, Program and Erase instructions, as all instructions are ignored except one particular instruction (the Release from Deep Power-down instruction).

Protected Area Sizes Sector Organization

Status Register Content ^{*1}						Memory Content ^{*2}			
CMP	4KBL BP4	TB BP3	BP2	BP1	BP0	Protect Areas	Addresses	Density	Portion
0	X	X	0	0	0	None	None	None	None
0	0	0	0	0	1	Block 31	1F0000h-1FFFFFFh	64KB	Upper 1/32
0	0	0	0	1	0	Block 30 to 31	1E0000h-1FFFFFFh	128KB	Upper 1/16
0	0	0	0	1	1	Block 28 to 31	1C0000h-1FFFFFFh	256KB	Upper 1/8
0	0	0	1	0	0	Block 24 to 31	180000h-1FFFFFFh	512KB	Upper 1/4
0	0	0	1	0	1	Block 16 to 31	100000h-1FFFFFFh	1024KB	Upper 1/2
0	0	1	0	0	1	Block 0	000000h-00FFFFh	64KB	Lower 1/32
0	0	1	0	1	0	Block 0 to 1	000000h-01FFFFh	128KB	Lower 1/16
0	0	1	0	1	1	Block 0 to 3	000000h-03FFFFh	256KB	Lower 1/8
0	0	1	1	0	0	Block 0 to 7	000000h-07FFFFh	512KB	Lower 1/4
0	0	1	1	0	1	Block 0 to 15	000000h-0FFFFFFh	1024KB	Lower 1/2
0	X	X	1	1	X	Block 0 to 31	000000h-1FFFFFFh	2048KB	All
0	1	0	0	0	1	Block 31	1FF000h-1FFFFFFh	4KB	Upper 1/512
0	1	0	0	1	0	Block 31	1FE000h-1FFFFFFh	8KB	Upper 1/256
0	1	0	0	1	1	Block 31	1FC000h-1FFFFFFh	16KB	Upper 1/128
0	1	0	1	0	X	Block 31	1F8000h-1FFFFFFh	32KB	Upper 1/64
0	1	1	0	0	1	Block 0	000000h-000FFFh	4KB	Lower 1/512
0	1	1	0	1	0	Block 0	000000h-001FFFh	8KB	Lower 1/256
0	1	1	0	1	1	Block 0	000000h-003FFFh	16KB	Lower 1/128
0	1	1	1	0	X	Block 0	000000h-007FFFh	32KB	Lower 1/64

Protected Area Sizes Sector Organization- Continued

Status Register Content ^{*1}						Memory Content ^{*2}			
CMP	4KBL BP4	TB BP3	BP2	BP1	BP0	Protect Areas	Addresses	Density	Portion
1	X	X	0	0	0	Block 0 to 31	000000h-1FFFFFFh	2048KB	All
1	0	0	0	0	1	Block 0 to 30	000000h-1EFFFFh	1948KB	Lower 31/32
1	0	0	0	1	0	Block 0 to 29	000000h-1DFFFFh	1920KB	Lower 15/16
1	0	0	0	1	1	Block 0 to 27	000000h-1BFFFFh	1792KB	Lower 7/8
1	0	0	1	0	0	Block 0 to 23	000000h-17FFFFh	1536KB	Lower 3/4
1	0	0	1	0	1	Block 0 to 15	000000h-0FFFFFFh	1024KB	Lower 1/2
1	0	1	0	0	1	Block 1 to 31	010000h-1FFFFFFh	1984KB	Upper 31/32
1	0	1	0	1	0	Block 2 to 31	020000h-1FFFFFFh	1920KB	Upper 15/16
1	0	1	0	1	1	Block 4 to 31	040000h-1FFFFFFh	1792KB	Upper 7/8
1	0	1	1	0	0	Block 8 to 31	080000h-1FFFFFFh	1536KB	Upper 3/4
1	0	1	1	0	1	Block 16 to 31	100000h-1FFFFFFh	1024KB	Upper 1/2
1	1	0	0	0	1	Block 0 to 31	000000h-1FEFFFFh	2044KB	Lower 511/512
1	1	0	0	1	0	Block 0 to 31	000000h-1FDFFFFh	2040KB	Lower 255/256
1	1	0	0	1	1	Block 0 to 31	000000h-1FBFFFFh	2032KB	Lower 127/128
1	1	0	1	0	X	Block 0 to 31	000000h-1F7FFFh	2016KB	Lower 63/64
1	1	1	0	0	1	Block 0 to 31	001000h-1FFFFFFh	2044KB	Upper 511/512
1	1	1	0	1	0	Block 0 to 31	002000h-1FFFFFFh	2040KB	Upper 255/256
1	1	1	0	1	1	Block 0 to 31	004000h-1FFFFFFh	2032KB	Upper 127/128
1	1	1	1	0	X	Block 0 to 31	008000h-1FFFFFFh	2016KB	Upper 63/64
1	X	X	1	1	X	None	None	None	None

Note:

1. X = don't care
2. If any Erase or Program command specifies a memory region that contains protected data portion, this command will be ignored.

INSTRUCTIONS

All instructions, addresses and data are shifted in and out of the device, most significant bit first. Serial Data Input (DI) is sampled on the first rising edge of Serial Clock (CLK) after Chip Select (CS#) is driven Low. Then, the one-byte instruction code must be shifted in to the device, most significant bit first, on Serial Data Input (DI), each bit being latched on the rising edges of Serial Clock (CLK).

The instruction set is listed in Instruction Set table. Every instruction sequence starts with a one-byte instruction code. Depending on the instruction, it might be followed by address bytes, or data bytes, or both or none. Chip Select (CS#) must be driven High after the last bit of the instruction sequence has been shifted in. In the case of a Read Data Bytes (READ), Read Data Bytes at Higher Speed (Fast_Read), Dual Output Fast Read (3Bh), Dual I/O Fast Read (BBh), Quad Output Fast Read (6Bh), Quad Input/Output FAST_READ (EBh) or Release from Deep Power-down, and Read Device ID (RDI) instruction, the shifted-in instruction sequence is followed by a data-out sequence. Chip Select (CS#) can be driven High after any bit of the data-out sequence is being shifted out.

In the case of a write instruction, Chip Select (CS#) must be driven High exactly at a byte boundary, otherwise the instruction is rejected, and is not executed. That is, Chip Select (CS#) must be driven High when the number of clock pulses after Chip Select (CS#) being driven Low is an exact multiple of eight. For Page Program, if at any time the input byte is not a full byte, nothing will happen and WEL will not be reset.

In the case of multi-byte commands of Page Program (PP), Quad Input Page Program (QPP) and Release from Deep Power Down (RES) minimum number of bytes specified has to be given, without which, the command will be ignored.

In the case of Page Program, if the number of byte after the command is less than 4 (at least 1 data byte), it will be ignored too. In the case of SE and HBE/BE, exact 24-bit address is a must, any less or more will cause the command to be ignored.

All attempts to access the memory array during a Write Status Register cycle, Program cycle or Erase cycle are ignored, and the internal Write Status Register cycle, Program cycle or Erase cycle continues unaffected.

Instruction Set

Instruction Name	Byte 1 Code	Byte 2	Byte 3	Byte 4	Byte 5	Byte 6	n-Bytes
RSTEN	66h						
RST ⁽¹⁾	99h						
Write Enable (WREN)	06h						
Volatile Status Register Write Enable ⁽³⁾	50h						
Write Disable (WRDI)	04h						
Read Status Register (RDSR)	05h	SR7-SR0					
Read Status Register 2 (RDSR2)	09h /35h	SR2.7-SR2.0					
Read Status Register 3 (RDSR3)	95h /15h	SR3.7-SR3.0					
Write Status Register (WRSR)	01h	SR7-SR0	SR2.7-SR2.0	SR3.7-SR3.0			
Write Status Register 2 (WRSR2)	31h	SR2.7-SR2.0					
Write Status Register 3 (WRSR3)	C0h /11h	SR3.7-SR3.0					
Write Suspend	75h/B0h						
Write Resume	7Ah/30h						
Deep Power-down	B9h						
Release from Deep Power-down, and read Device ID (RES)	ABh	dummy	dummy	dummy	(ID7-ID0)		(5)
Release from Deep Power-down (RDP)							
Manufacturer/ Device ID	90h	dummy	dummy	00h	(M7-M0)	(ID7-ID0)	(6)
				01h	(ID7-ID0)	(M7-M0)	
Read Identification (RDID)	9Fh	(M7-M0)	(ID15-ID8)	(ID7-ID0)	(6)		
Read SFDP mode	5Ah	A23-A16	A15-A8	A7-A0	dummy	(D7-D0)	(Next Byte) continuous
Read Unique ID	4Bh	00h	00h	00h	dummy	(UID7-UID0)	continuous
Erase Security Registers	44h	A23-A16	A15-A8	A7-A0			
Program Security Registers	42h	A23-A16	A15-A8	A7-A0	(D7-D0)	(Next Byte)	continuous
Read Security Registers	48h	A23-A16	A15-A8	A7-A0	dummy	(D7-D0)	(Next Byte) continuous
Set Burst with Wrap	77h	dummy	dummy	dummy	W7-W0		

Note:

- RST command only executed if RSTEN command is executed first. Any intervening command will disable Reset.
- Volatile Status Register Write Enable command must precede WRSR command without any intervening commands to write data to Volatile Status Register.
- Data bytes are shifted with Most Significant Bit first. Byte fields with data in parenthesis "()" indicate data being read from the device on the DO pin.
- The Device ID will repeat continuously until CS# terminates the instruction.
- The Manufacturer ID and Device ID bytes will repeat continuously until CS# terminates the instruction. 00h on Byte 4 starts with MID and alternate with DID, 01h on Byte 4 starts with DID and alternate with MID.
- (M7-M0): Manufacturer, (ID15-ID8): Memory Type, (ID7-ID0): Memory Capacity.

Instruction Set (Read Instruction)

Instruction Name	OP Code	Address bits	Dummy bits / Clocks (Default)	Data Out	Remark
Read Data	03h	24 bits	0	(D7-D0, ...)	(Next Byte) continuous
Fast Read	0Bh	24 bits	8 bits / 8 clocks	(D7-D0, ...)	(Next Byte) continuous
Dual Output Fast Read	3Bh	24 bits	8 bits / 8 clocks	(D7-D0, ...)	(one byte Per 4 clocks, continuous)
Dual I/O Fast Read	BBh	24 bits	8 bits / 4 clocks	(D7-D0, ...)	(one byte Per 4 clocks, continuous)
Quad Output Fast Read	6Bh	24 bits	8 bits / 8 clocks	(D7-D0, ...)	(one byte per 2 clocks, continuous)
Quad I/O Fast Read	EBh	24 bits	24 bits / 6 clocks	(D7-D0, ...)	(one byte per 2 clocks, continuous)

Instruction Set (Program Instruction)

Instruction Name	OP Code	Address bits	Dummy bits / Clocks (Default)	Data In	Remark
Page Program (PP)	02h	24 bits	0	(D7-D0, ...)	(Next Byte) continuous
Quad Input Page Program (QPP)	32h	24 bits	0	(D7-D0, ...)	(one byte per 2 clocks, continuous)

Instruction Set (Erase Instruction)

Instruction Name	OP Code	Address bits	Dummy bits / Clocks (Default)	Data Out	Remark
Sector Erase (SE)	20h	24 bits	0	-	
32K Half Block Erase (HBE)	52h	24 bits	0	-	
64K Block Erase (BE)	D8h	24 bits	0	-	
Chip Erase (CE)	C7h/ 60h	0 bits	0	-	

Manufacturer and Device Identification

OP Code	(M7-M0)	(ID15-ID0)	(ID7-ID0)
ABh			14h
90h	1Ch		14h
9Fh	1Ch	6115h	

Reset-Enable (RSTEN) (66h) and Reset (RST) (99h)

The Reset operation is used as a system (software) reset that puts the device in normal operating Ready mode and lost all the current volatile setting, such as Volatile Status Register bits, Write Enable Latch status (WEL) Program/Erase Suspend status, Read Parameter (P7-0) Deep Power Down Mode, Continuous Read Mode bit setting (M7-0) and Wrap Bit Setting (W6-4). This operation consists of two commands: Reset-Enable (RSTEN) and Reset (RST).

To reset the device the host drives CS# low, sends the Reset-Enable command (66h), and drives CS# high. Next, the host drives CS# low again, sends the Reset command (99h), and drives CS# high.

The Reset operation requires the Reset-Enable command followed by the Reset command. Any command other than the Reset command after the Reset-Enable command will disable the Reset-Enable.

A successful command execution will reset the status register, see Reset-Enable and Reset Sequence Diagram figure for SPI Mode. A device reset during an active Program or Erase operation aborts the operation, which can cause the data of the targeted address range to be corrupted or lost. Depending on the prior operation, the reset timing may vary. Recovery from a Write operation requires more software latency time (t_{SR}) than recovery from other operations.

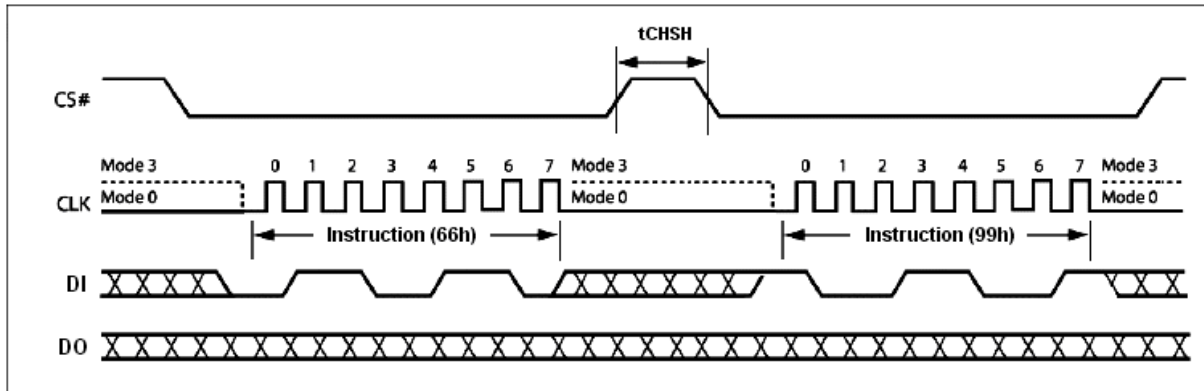

Reset-Enable and Reset Sequence Diagram

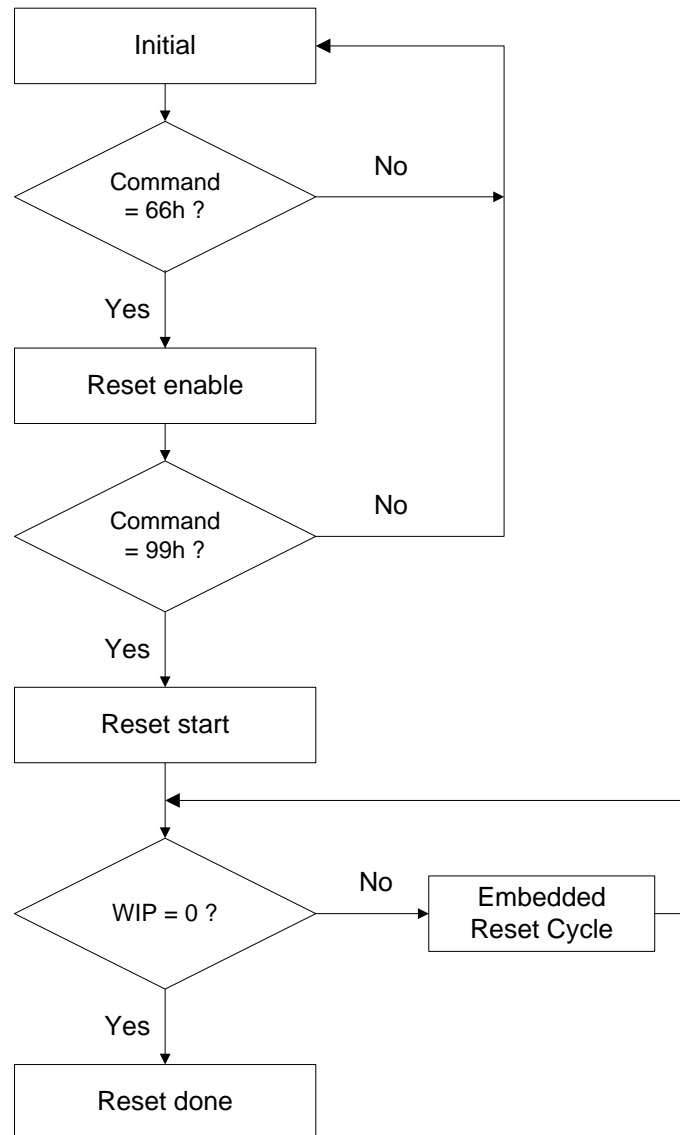
Software Reset Flow

Note:

1. Reset-Enable (RSTEN) (66h) and Reset (RST) (99h) commands need to match standard SPI.
2. The reset command could be executed during embedded program and erase process.
3. This flow can release the device from Deep power down mode.
4. The Status Register Bit and Status Register 2 Bit will reset to default value after reset done.
5. If user reset device during erase, the embedded reset cycle software reset latency will take about 28us in worst case.

Write Enable (WREN) (06h)

The Write Enable (WREN) instruction (Write Enable Instruction Sequence Diagram figure) sets the Write Enable Latch (WEL) bit. The Write Enable Latch (WEL) bit must be set prior to every Page Program (PP), Quad Input Page Program (QPP), Sector Erase (SE), Block Erase (HBE/BE), Chip Erase (CE) and Write Status Register (WRSR/ WRSR3) instruction.

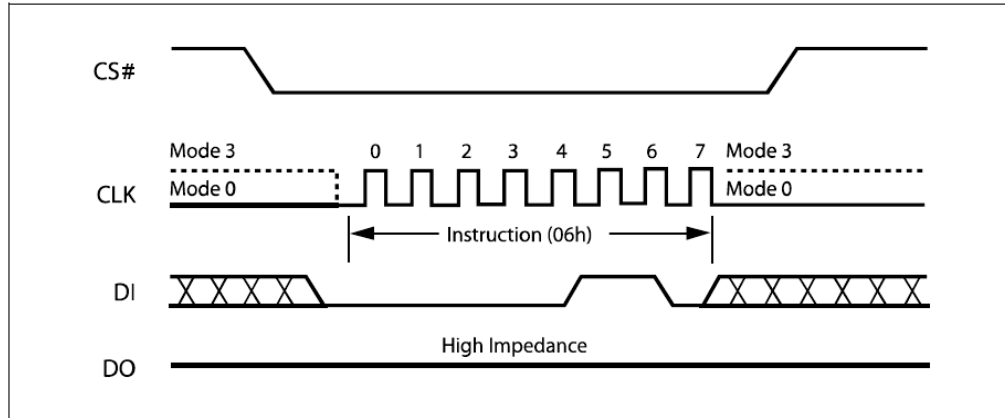
The Write Enable (WREN) instruction is entered by driving Chip Select (CS#) Low, sending the instruction code, and then driving Chip Select (CS#) High.

Write Enable Instruction Sequence Diagram
Volatile Status Register Write Enable (50h)

This feature enable user to change memory protection schemes quickly without waiting for the typical non-volatile bit write cycles or affecting the endurance of the Status Register non-volatile bits. The Volatile Status Register Write Enable (50h) command won't set the Write Enable Latch (WEL) bit, it is only valid for 'Write Status Register' (01h) command to change the Volatile Status Register bit values.

To write to Volatile Status Register, issue the Volatile Status Register Write Enable (50h) command prior issuing WRSR (01h). The Status Register bits will be refresh to Volatile Status Register (SR[7:2]) within t_{SHSL2} (50ns). Upon power off or the execution of a Software/Hardware Reset, the volatile Status Register bit values will be lost, and the non-volatile Status Register bit values will be restored. The instruction sequence is shown in Volatile Status Register Write Enable Instruction Sequence Diagram figure.

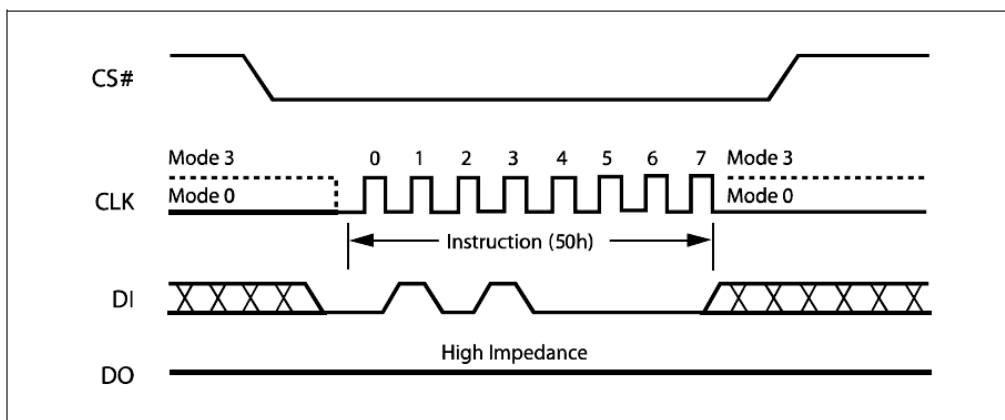
Volatile Status Register Write Enable Instruction Sequence Diagram

Write Disable (WRDI) (04h)

The Write Disable instruction (Write Disable Instruction Sequence Diagram figure) resets the Write Enable Latch (WEL) bit in the Status Register to a 0. The Write Disable instruction is entered by driving Chip Select (CS#) low, shifting the instruction code "04h" into the DI pin and then driving Chip Select (CS#) high. Note that the WEL bit is automatically reset after Power-up and upon completion of the Write Status Register, Page Program, Sector Erase, Block Erase (HBE/BE) and Chip Erase instructions.

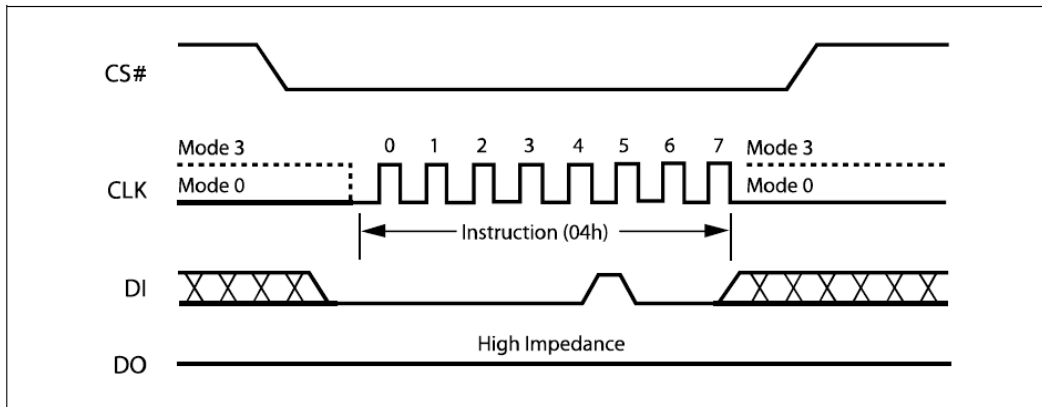

Write Disable Instruction Sequence Diagram

Read Status Register (RDSR) (05h)

The Read Status Register (RDSR) instruction allows the Status Register to be read. The Status Register may be read at any time, even while a Program, Erase or Write Status Register cycle is in progress. When one of these cycles is in progress, it is recommended to check the Write in Progress (WIP) bit before sending a new instruction to the device.

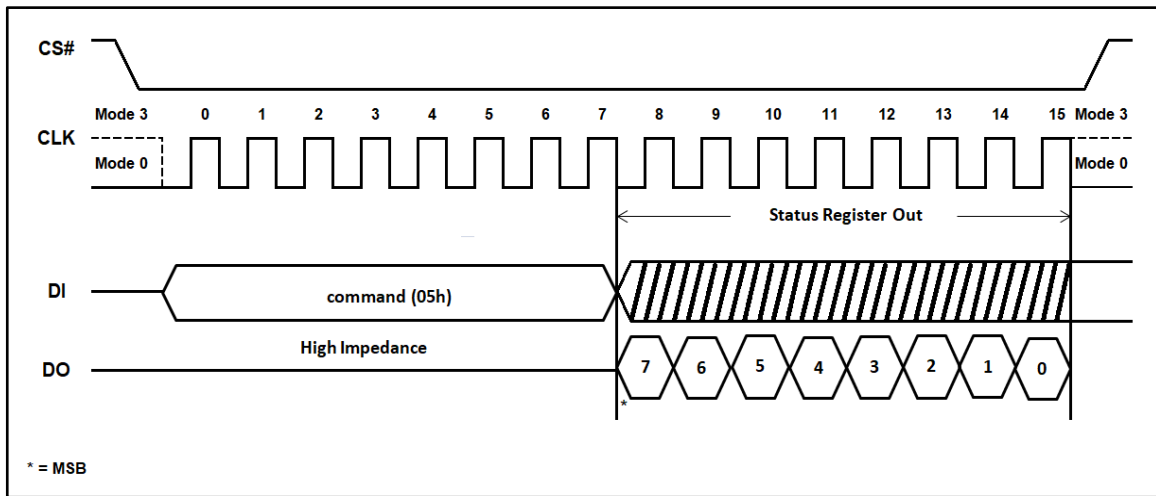

Read Status Register Instruction Sequence Diagram

Status Register Bit Locations

SR7	SR6	SR5	SR4	SR3	SR2	SR1	SR0
SRP bit (Status Register Protect)	4KBL bit (4KB boot lock)	TB bit (Top / Bottom Protect)	BP2 bit (Block Protected)	BP1 bit (Block Protected)	BP0 bit (Block Protected)	WEL bit (Write Enable Latch)	WIP bit (Write In Progress)
1 = status register write disable	1 = Sector 0 = 64KB Block (default 0)	1 = Bottom 0 = Top (default 0)	(note 1)	(note 1)	(note 1)	1 = write enable 0 = not write enable	1 = write operation 0 = not in write operation
Volatile bit / Non-volatile bit	Volatile bit / Non-volatile bit	Volatile bit / Non-volatile bit	Volatile bit / Non-volatile bit	Volatile bit / Non-volatile bit	Volatile bit / Non-volatile bit	Read only bit	Read only bit

Note:

1. See the "Protected Area Sizes Sector Organization" table.

The status and control bits of the Status Register are as follows:

SRP bit. The Status Register Protect (SRP) bit is operated in conjunction with the Write Protect (WP#) signal. The Status Register Write Protect (SRP) bit and Write Protect (WP#) signal allow the device to be put in the Hardware Protected mode (when the Status Register Protect (SRP) bit is set to 1, and Write Protect (WP#) is driven Low). In this mode, the bits of the Status Register (4KBL, TB, BP2, BP1, BP0) become read-only bits and the Write Status Register (WRSR) instruction is no longer accepted for execution.

4KBL bit. The 4KB Boot Lock bit (4KBL) is set by WRSR command. 4KBL also controls Block Protect table, please refer to Protected Area Sizes Sector Organization Table.

TB bit. The Top/Bottom Protect Bit (TB) controls if the Block Protect Bits (BP2, BP1, BP0) protect from the Top (TB = 0) or the Bottom (TB = 1) of the array as shown in the Protected Area Sizes Sector Organization table. The factory default setting is TB = 0. The TB bit can be set with the Write Status Register instruction.

BP2, BP1, BP0 bits. The Block Protect (BP2, BP1, BP0) bits are non-volatile. They define the size of the area to be software protected against Program and Erase instructions. These bits are written with the Write Status Register (WRSR) instruction. When one or both of the Block Protect (BP2, BP1, BP0) bits is set to 1, the relevant memory area (as defined in Table 3.) becomes protected against Page Program (PP), Quad Input Page Program (QPP), Sector Erase (SE) and Block Erase (HBE/BE) instructions. The Block Protect (BP2, BP1, BP0) bits can be written and provided that the Hardware Protected mode has not been set. The Chip Erase (CE) instruction is executed if all memory regions aren't protected by the Block Protect (CMP, 4KBL, TB, BP2, BP1, BP0) bits and EBL bit is 0.

WEL bit. The Write Enable Latch (WEL) bit indicates the status of the internal Write Enable Latch. When set to 1 the internal Write Enable Latch is set, when set to 0 the internal Write Enable Latch is reset and no Write Status Register, Program or Erase instruction is accepted.

WIP bit. The Write In Progress (WIP) bit indicates whether the memory is busy with a Write Status Register, Program or Erase cycle. When set to 1, such a cycle is in progress, when reset to 0 no such cycle is in progress.

Read Status Register 2 (RDSR2) (09h/35h)

The Read Status Register 2 (RDSR2) instruction allows the Status Register 2 to be read. The Status Register 2 may be read at any time, even while a Write Suspend or Write Resume cycle is in progress, OTP array lock bits, QE bits enable or not and BP protection table related bit: CMP. When one of these cycles is in progress, it is recommended to check the Write in Progress (WIP) bit before sending a new instruction to the device.

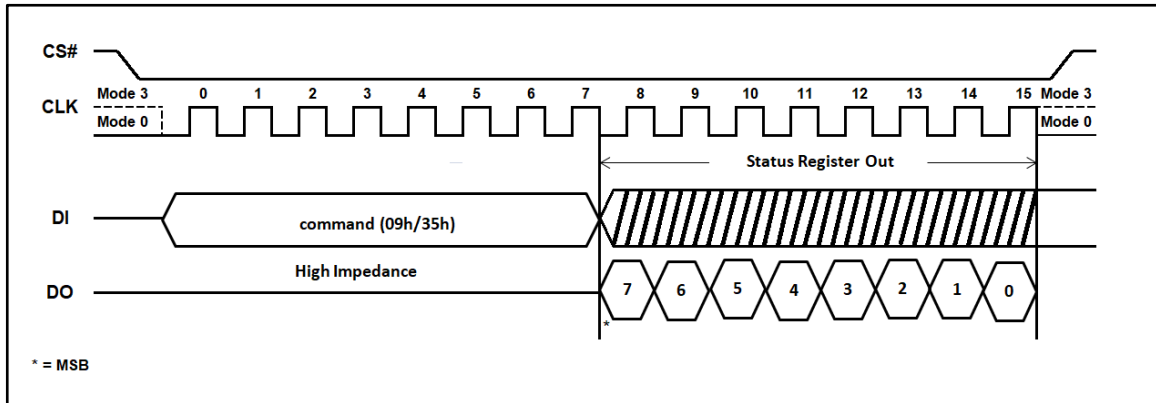

Read Status Register 2 Instruction Sequence Diagram

Status Register 2 Bit Locations

SR2.7	SR2.6	SR2.5	SR2.4	SR2.3	SR2.2	SR2.1	SR2.0
WSE bit (Write Suspend Erase status bit)	CMP bit	SPL0 bit	SPL1 bit	SPL2 bit	WSP bit (Write Suspend Program bits)	QE bit	Reserved bit
1 = Erase suspended 0 = Erase is not suspended	(note 2)	1 = OTP1 sector is protected	1 = OTP2 sector is protected	1 = OTP3 sector is protected	1 = Program suspended 0 = Program is not suspended	1 = WP# and HOLD#/RESET# disable 0 = WP# and HOLD#/RESET# enable (default 0)	
Indicator bit	Non-volatile / Volatile bit	OTP bit	OTP bit	OTP bit	Indicator bit	Non-volatile / Volatile bit	

Note:

1. The default of each volatile bit is “0” at Power-up or after reset.
2. See the “Protected Area Sizes Sector Organization” table.

The status and control bits of the Suspend Status Register 2 are as follows:

WSE bit. The Write Suspend Erase Status (WSE) bit indicates when an Erase operation has been suspended. The WSE bit is “1” after the host issues a suspend command during an Erase operation. Once the suspended Erase resumes, the WSE bit is reset to “0”.

CMP bit. The Complement Protect bit(CMP) is a non-volatile bit in Status Register 2. It is used in conjunction with 4KBL, TB, BP2, BP1, BP0 bits to provide more flexibility for the array protection. The default setting is CMP=0.

SPL0 bit. The SPL0 bit is non-volatile One Time Program (OTP) bit in status register that provide the write protect control and status to the security sector 0. User can read/program/erase security sector 0 as normal sector while SPL0 value is equal 0, after SPL0 is programmed with 1 by WRSR command, the security sector 0 is protected from program and erase operation. The SPL0 bit can only be programmed once.

SPL1 bit. The SPL1 bit is non-volatile One Time Program (OTP) bit in status register that provide the write protect control and status to the security sector 1. User can read/program/erase security sector 1 as normal sector while SPL1 value is equal 0, after SPL1 is programmed with 1 by WRSR command, the security sector 1 is protected from program and erase operation. The SPL1 bit can only be programmed once.

SPL2 bit. The SPL2 bit is non-volatile One Time Program (OTP) bit in status register that provide the write protect control and status to the security sector 2. User can read/program/erase security sector 2 as normal sector while SPL2 value is equal 0, after SPL2 is programmed with 1 by WRSR command, the security sector 2 is protected from program and erase operation. The SPL2 bit can only be programmed once.

WSP bit. The Write Suspend Program Status (WSP) bit indicates when a Program operation has been suspended. The WSP is “1” after the host issues a suspend command during the Program operation. Once the suspended Program resumes, the WSP bit is reset to “0”.

QE bit. The Quad Enable (QE) bit is a non-volatile Read/Write bit in the Status Register 2 to disable WP# and Hold# before Quad operation. When it is “0” (factory default), the WP# and HOLD# are enabled.

On the other hand, while QE bit is “1”, the WP# and HOLD# are disabled.

User can use Flash Programmer to set QE bit as “1” and then the host system can let WP# and HOLD# keep floating in SPI mode.

SRP	WP#	Status	Description
0	X	Software protect	Status register can be changed
1	0	Hardware protect	Status register is locked
1	1	Hardware unprotect	Status register can be changed

Reserved bit. Status Register 2, bit locations SR2.0 are reserved for future use. Current devices will read 0 for these bit locations. It is recommended to mask out the reserved bit when testing the Suspend Status Register. Doing this will ensure compatibility with future devices.

Read Status Register 3 (RDSR3) (95h/15h)

The Read Status Register 3 (RDSR3) instruction allows the Status Register 3 to be read. The Status Register 3 may be read at any time, even while output drive strength setting, wrap read length, blank check bit and dummy byte bit. When one of these bytes is in progress, it is recommended to check the Write in Progress (WIP) bit before sending a new instruction to the device.

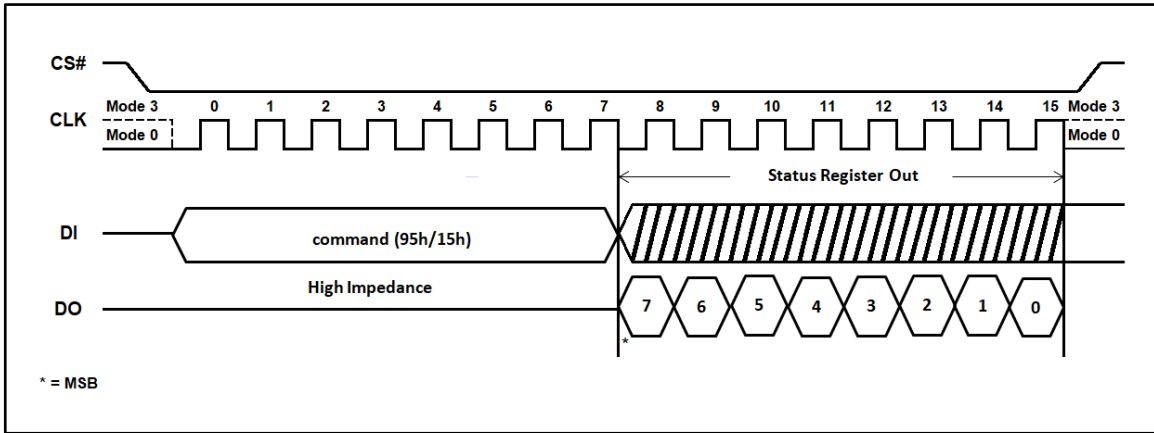

Read Status Register 3 Instruction Sequence Diagram

Status Register 3 Bit Locations

SR3.7	SR3.6	SR3.5	SR3.4	SR3.3	SR3.2	SR3.1	SR3.0
Dummy configuration bit	Output Drive Strength bit		Burst Length bit		Blank check bit	WEL bit (Write Enable Latch)	WIP bit (Write In Progress)
0= default dummy byte(default) 1 = more dummy byte at BBh/EBh for higher speed	00 = 67% (default) 01 = 100% 10 = 50% Drive 11 = 83% Drive		00 = 8 Bytes (default) 01 = 16 Bytes 10 = 32 Bytes 11 = 64 Bytes		1 = flash is blank after ship out (default) 0 = flash had been programmed	1 = write enable 0 = not write enable	1 = write operation 0 = not in write operation
Non-volatile/volatile bit	Non-volatile/volatile bit		Indicator bit		Indicator bit	Read only bit	Read only bit

The status and control bits of the Status Register 3 are as follows:

Dummy configuration bit. While set DC (dummy configuration) to 1, it provides more latency time while flash preparing to output data.

Read Command	Dummy configuration	Number of dummy clk
BBh	0 (default)	4
	1	8
EBh	0 (default)	6
	1	10

Output Drive Strength bit. The Output Drive Strength (SR3.6 and SR3.5) bits indicate the status of output Drive Strength in I/O pins.

Burst Length bit. The Burst Length (SR3.4 and SR3.3) bits indicate the status of wrap burst read length. The Burst Length feature is set by “Set Burst with Wrap (77h)” operation. These two bits only show the Burst Length.

Blank check bit. This bit is related with whole chip blank as factory default. Once any byte is programmed, this bit turns to 0 and will not be restored by further erase operation.

WEL bit. The Write Enable Latch (WEL) bit indicates the status of the internal Write Enable Latch. When set to 1 the internal Write Enable Latch is set, when set to 0 the internal Write Enable Latch is reset and no Write Status Register, Program or Erase instruction is accepted.

WIP bit. The Write in Progress (WIP) bit indicates whether the memory is busy with a Write Status Register, Program or Erase cycle. When set to 1, such a cycle is in progress, when reset to 0 no such cycle is in progress.

Write Status Register (WRSR) (01h)

The Write Status Register (WRSR) instruction allows new values to be written to the Status Registers. Before it can be accepted, a Write Enable (WREN) instruction must previously have been executed. After the Write Enable (WREN) instruction has been decoded and executed, the device sets the Write Enable Latch (WEL).

The Write Status Register (WRSR) instruction is entered by driving Chip Select (CS#) Low, followed by the instruction code and the data byte or data bytes on Serial Data Input (DI). The WRSR instruction also support multi bytes data input to set other status registers.

The instruction sequence is shown in Write Status Register Instruction Sequence Diagram figure and Write Status Register Instruction Sequence Diagram (multi byte) (3byte) figure. The Write Status Register (WRSR) instruction has no effect on S1 and S0 of the Status Register. Chip Select (CS#) must be driven High after the 8th or 16th or 24th bits of the data byte has been latched in. If not, the Write Status Register (WRSR) instruction is not executed. As soon as Chip Select (CS#) is driven High, the self-timed Write Status Register cycle (whose duration is t_w) is initiated. While the Write Status Register cycle is in progress, the Status Register may still be read to check the value of the Write in Progress (WIP) bit. The Write in Progress (WIP) bit is 1 during the self-timed Write Status Register cycle, and is 0 when it is completed. When the cycle is completed, the Write Enable Latch (WEL) is reset.

The Write Status Register (WRSR) instruction allows the user to change the values of the Block Protect (CMP, 4KBL, TB, BP2, BP1, BP0) bits, to define the size of the area that is to be treated as read-only, as defined in Protected Area Sizes Sector Organization table. The Write Status Register (WRSR) instruction also allows the user to set or reset the Status Register Protect (SRP) bit in accordance with the Write Protect (WP#) signal. The Status Register Protect (SRP) bit and Write Protect (WP#) signal allow the device to be put in the Hardware Protected Mode (HPM). The Write Status Register (WRSR) instruction is not executed once the Hardware Protected Mode (HPM) is entered.

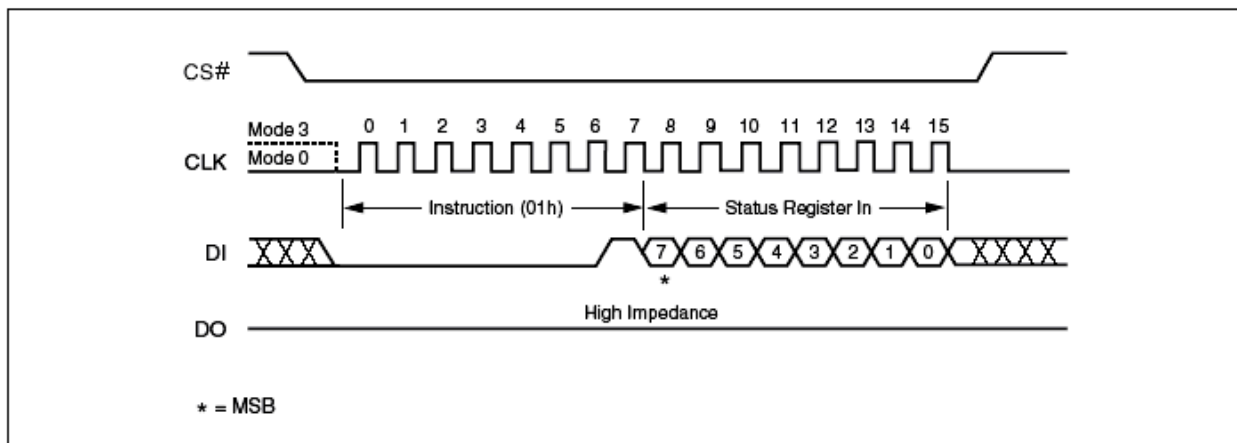
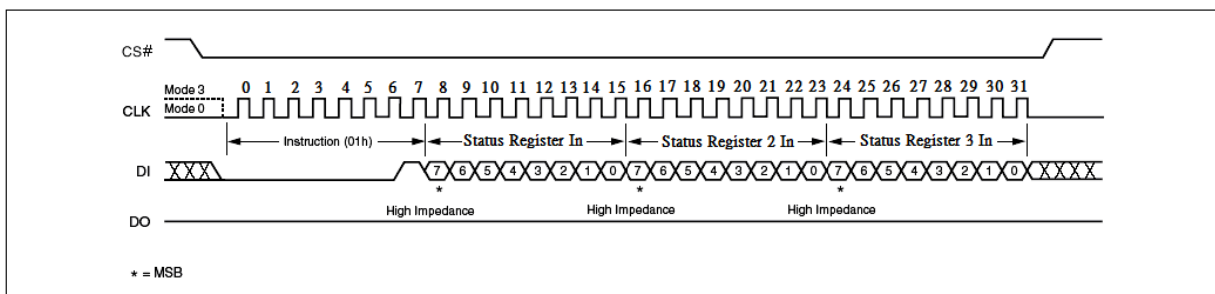

Write Status Register Instruction Sequence Diagram

Write Status Register Instruction Sequence Diagram (multi byte) (3byte)

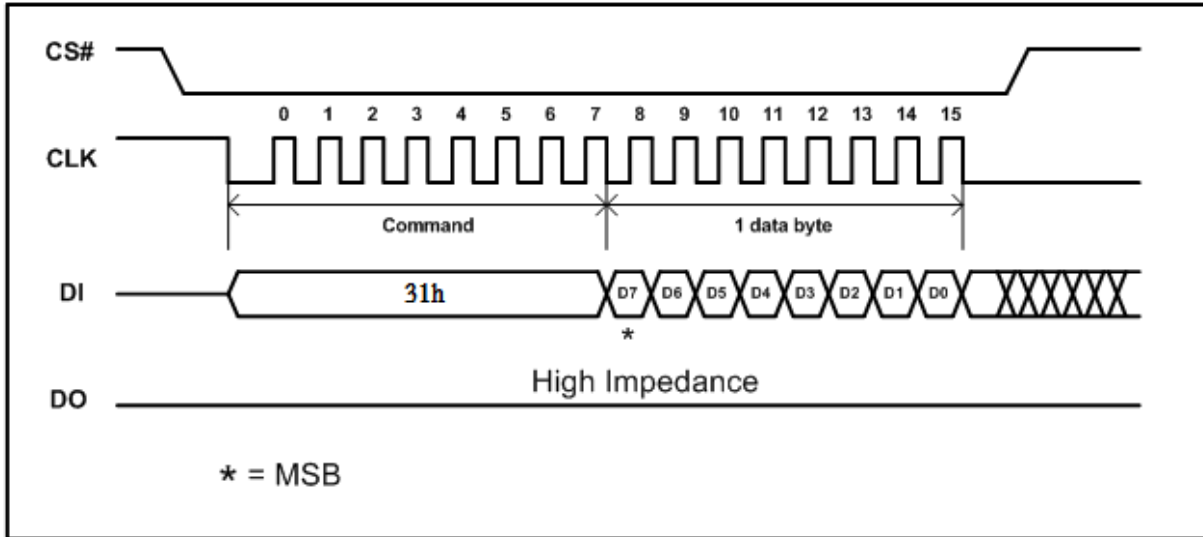
Write Status Register 2 (31h/01h)

The Write Status Register 2(31h) command can be used to set SPL0/SPL1/SPL2 OTP bits , QE bit, CMP bit To set these bits to the host driver CS# low, sends the Write Status Register 2(31h) and one data byte, then drivers CS# high. 01h (WRSR) command also can set status register 2.

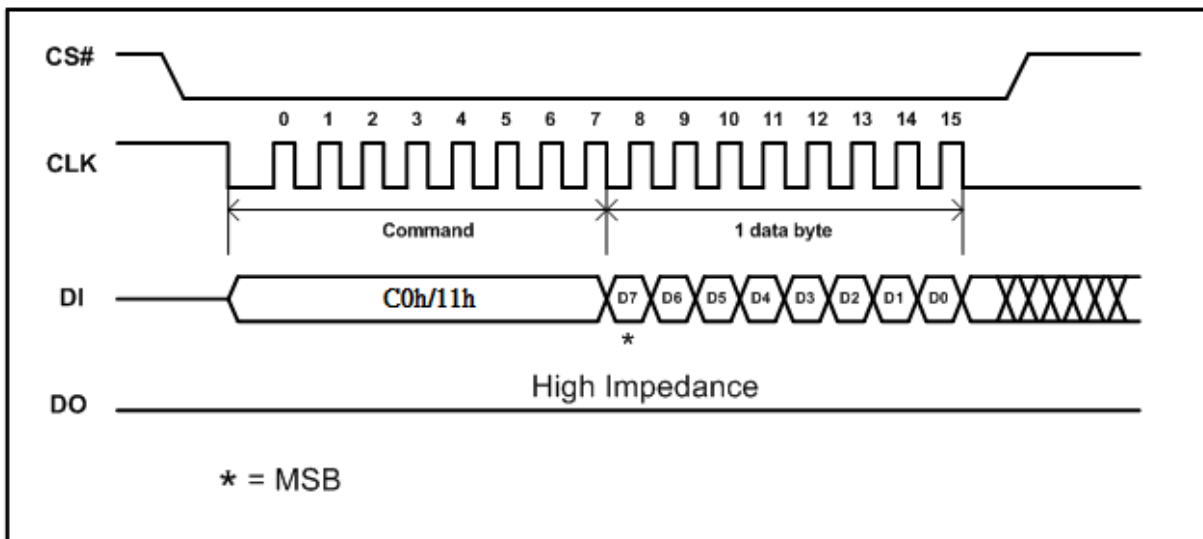
Write Status Register 2 Instruction Sequence Diagram
Write Status Register 3 (C0h/11h/01h)

The Write Status Register 3 (C0h/11h) command can be used to set output drive strength in I/O pins and dummy configuration for read command bit. To set these bits to the host driver CS# low, sends the Write Status Register 3 (C0h or 11h) and one data byte, then drivers CS# high. 01h (WRSR) command also can set status register 3.



Write Status Register 3 Instruction Sequence Diagram

Read Data Bytes (READ) (03h)

The device is first selected by driving Chip Select (CS#) Low. The instruction code for the Read Data Bytes (READ) instruction is followed by a 3-byte address (A23-A0), each bit being latched-in during the rising edge of Serial Clock (CLK). Then the memory contents, at that address, is shifted out on Serial Data Output (DO), each bit being shifted out, at a maximum frequency f_R , during the falling edge of Serial Clock (CLK).

The instruction sequence is shown in Read Data Instruction Sequence Diagram figure. The first byte addressed can be at any location. The address is automatically incremented to the next higher address after each byte of data is shifted out. The whole memory can, therefore, be read with a single Read Data Bytes (READ) instruction. When the highest address is reached, the address counter rolls over to 000000h, allowing the read sequence to be continued indefinitely.

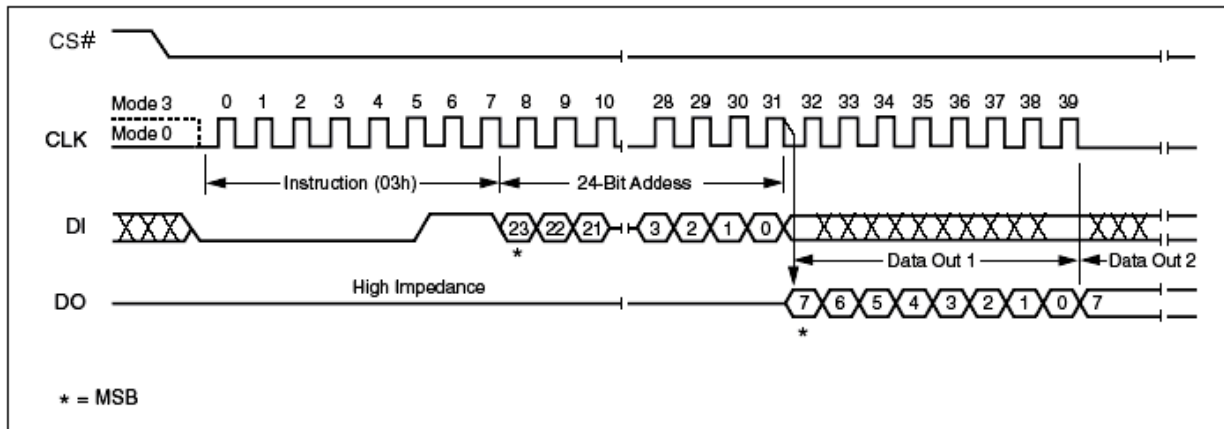
The Read Data Bytes (READ) instruction is terminated by driving Chip Select (CS#) High. Chip Select (CS#) can be driven High at any time during data output. Any Read Data Bytes (READ) instruction, while an Erase, Program or Write cycle is in progress, is rejected without having any effects on the cycle that is in progress.



Read Data Instruction Sequence Diagram

Read Data Bytes at Higher Speed (FAST_READ) (0Bh)

The device is first selected by driving Chip Select (CS#) Low. The instruction code for the Read Data Bytes at Higher Speed (FAST_READ) instruction is followed by a 3-byte address (A23-A0) and a dummy byte, each bit being latched-in during the rising edge of Serial Clock (CLK). Then the memory contents, at that address, is shifted out on Serial Data Output (DO), each bit being shifted out, at a maximum frequency F_R , during the falling edge of Serial Clock (CLK).

The instruction sequence is shown in Fast Read Instruction Sequence Diagram figure. The first byte addressed can be at any location. The address is automatically incremented to the next higher address after each byte of data is shifted out. The whole memory can, therefore, be read with a single Read Data Bytes at Higher Speed (FAST_READ) instruction. When the highest address is reached, the address counter rolls over to 000000h, allowing the read sequence to be continued indefinitely.

The Read Data Bytes at Higher Speed (FAST_READ) instruction is terminated by driving Chip Select (CS#) High. Chip Select (CS#) can be driven High at any time during data output. Any Read Data Bytes at Higher Speed (FAST_READ) instruction, while an Erase, Program or Write cycle is in progress, is rejected without having any effects on the cycle that is in progress.

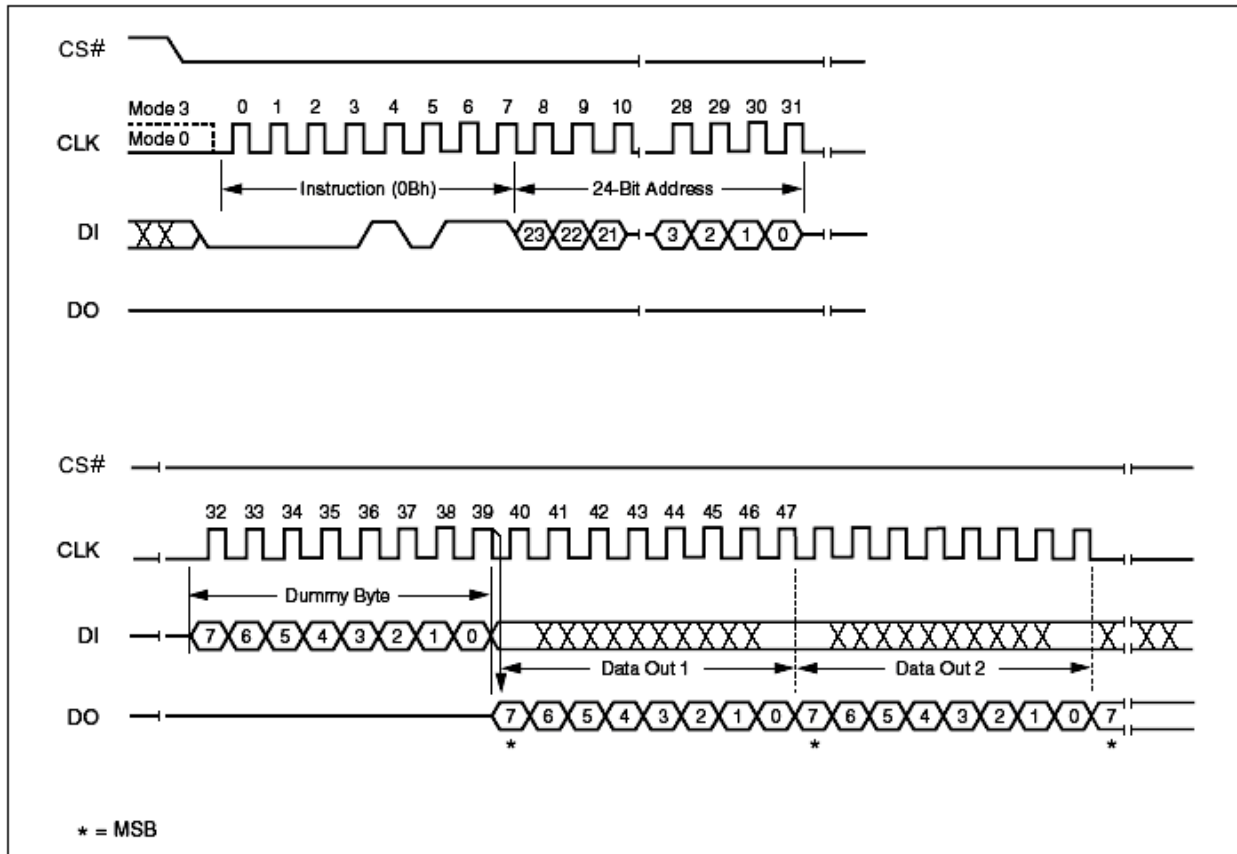
Fast Read Instruction Sequence Diagram

Dual Output Fast Read (3Bh)

The Dual Output Fast Read (3Bh) is similar to the standard Fast Read (0Bh) instruction except that data is output on two pins, DQ₀ and DQ₁, instead of just DQ₁. This allows data to be transferred from the device at twice the rate of standard SPI devices. The Dual Output Fast Read instruction is ideal for quickly downloading code from RAM upon power-up or for applications that cache code-segments to RAM for execution.

Similar to the Fast Read instruction, the Dual Output Fast Read instructions can operation at the highest possible frequency of F_R (see AC Electrical Characteristics). This is accomplished by adding eight “dummy clocks after the 24-bit address as shown in Dual Output Fast Read Instruction Sequence Diagram figure. The dummy clocks allow the device’s internal circuits additional time for setting up the initial address. The input data during the dummy clock is “don’t care”. However, the DI pin should be high-impedance prior to the falling edge of the first data out clock.

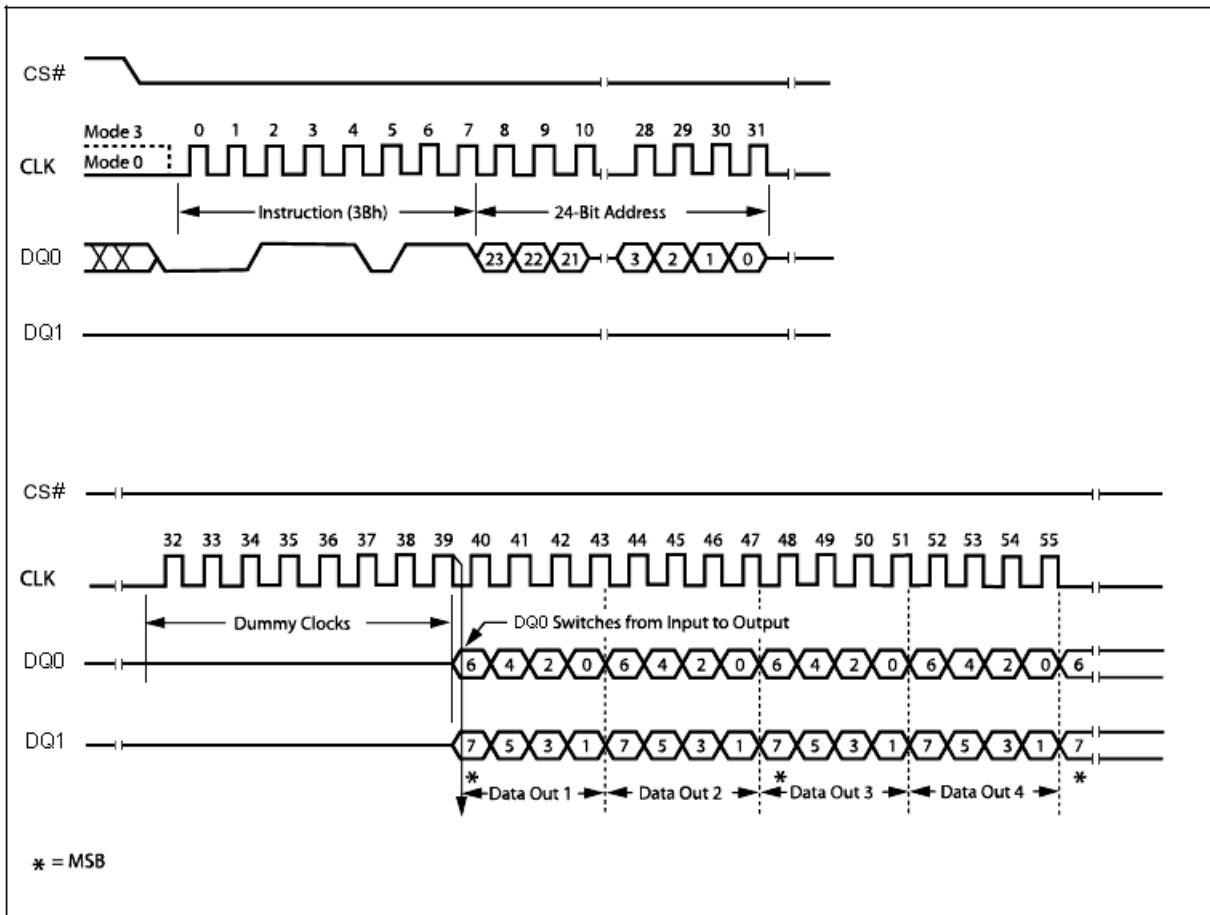

Dual Output Fast Read Instruction Sequence Diagram

Dual Input / Output FAST_READ (BBh)

The Dual I/O Fast Read (BBh) instruction allows for improved random access while maintaining two IO pins, DQ₀ and DQ₁. It is similar to the Dual Output Fast Read (3Bh) instruction but with the capability to input the Address bits (A23-0) two bits per clock. This reduced instruction overhead may allow for code execution (XIP) directly from the Dual SPI in some applications.

The Dual I/O Fast Read instruction enable double throughput of Serial Flash in read mode. The address is latched on rising edge of CLK, and data of every two bits (interleave 2 I/O pins) shift out on the falling edge of CLK at a maximum frequency. The first address can be at any location. The address is automatically increased to the next higher address after each byte data is shifted out, so the whole memory can be read out at a single Dual I/O Fast Read instruction. The address counter rolls over to 0 when the highest address has been reached. Once writing Dual I/O Fast Read instruction, the following address/dummy/data out will perform as 2-bit instead of previous 1-bit, as shown in Dual Input / Output Fast Read Instruction Sequence Diagram (M5-4 ≠ (1,0)) figure.

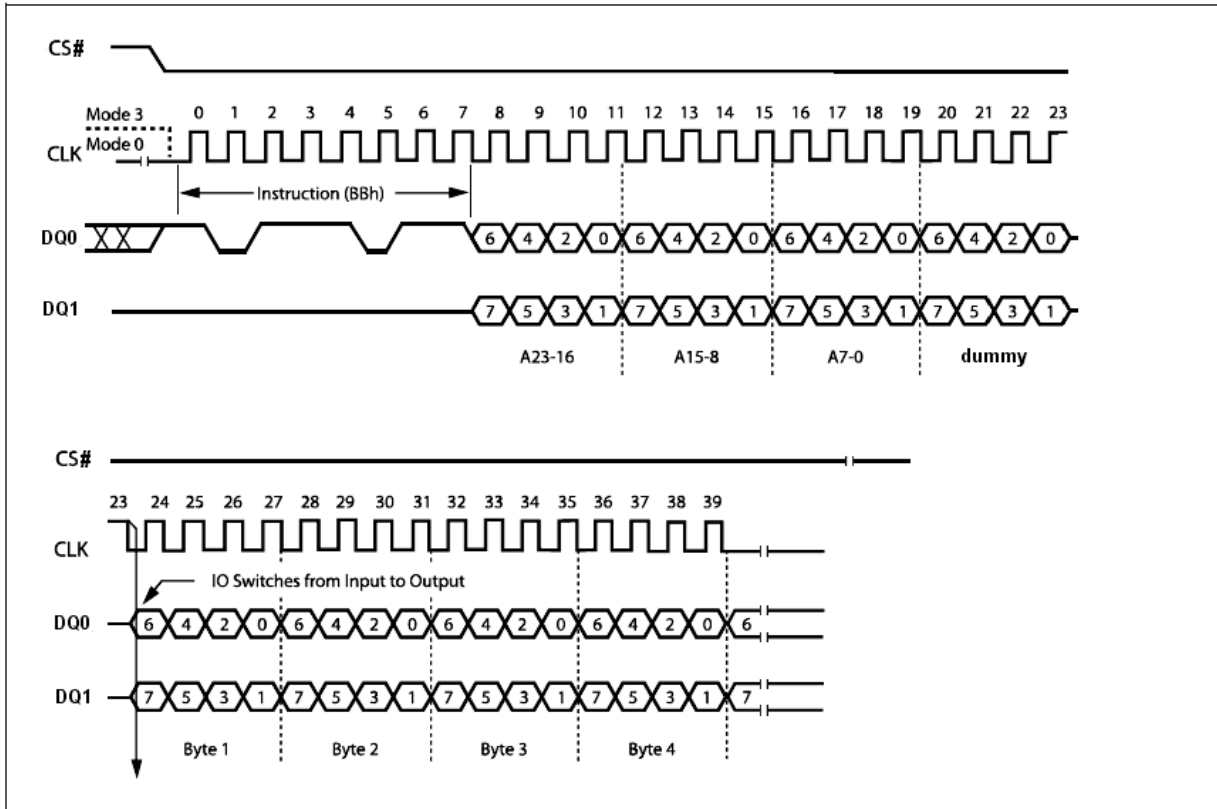

Dual Input / Output Fast Read Instruction Sequence Diagram (M5-4 ≠ (1,0))

Dual I/O Fast Read with “Enhance Read Mode”

The Dual I/O Fast Read command can further reduce command overhead through setting the “Enhance Read Mode” bits (M7-0) after the input 3-byte address (A23-A0). If the “Enhance Read Mode” bits (M5-4) = (1, 0), then the next Dual I/O Fast Read command does not require the BBh command code while next CS# goes low. If the “Enhance Read Mode” bits (M5-4) ≠ (1, 0), the next command needs the command code. A “Enhance Read Mode” Reset command can be used to reset (M5-4) before issuing normal command.

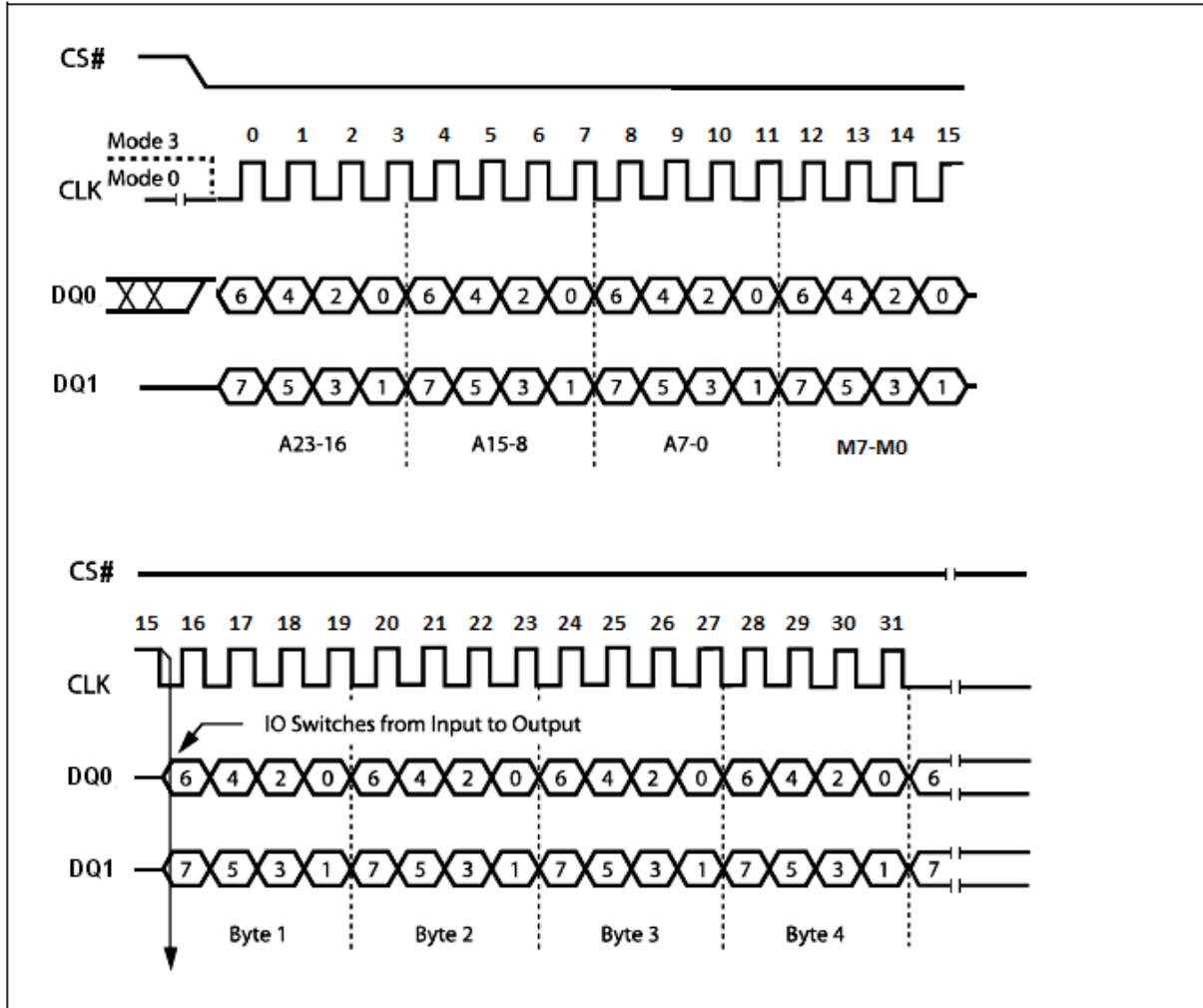

Dual Input / Output Fast Read Instruction Sequence Diagram with “Enhance Read Mode” (M5-4 = (1,0))

Quad Output Fast Read (6Bh)

The Quad Output Fast Read (6Bh) instruction is similar to the Dual Output Fast Read (3Bh) instruction except that data is output through four pins, DQ0, DQ1, DQ2 and DQ3 and eight dummy clocks are required prior to the data output. The Quad Output dramatically reduces instruction overhead allowing faster random access for code execution (XIP) directly from the Quad SPI.

The Quad Output Fast Read (6Bh) address is latching on rising edge of CLK, and data of every four bits (interleave on 4 I/O pins) shift out on the falling edge of CLK at a maximum frequency F_R . The first address can be any location. The address is automatically increased to the next higher address after each byte data is shifted out, so the whole memory can be read out at a single Quad Output Fast Read instruction. The address counter rolls over to 0 when the highest address has been reached.

The sequence of issuing Quad Output Fast Read (6Bh) instruction is: CS# goes low -> sending Quad Output Fast Read (6Bh) instruction -> 24-bit address on DQ0 -> 8 dummy clocks -> data out interleave on DQ3, DQ2, DQ1 and DQ0 -> to end Quad Output Fast Read (6Bh) operation can use CS# to high at any time during data out, as shown in Quad Output Fast Read Instruction Sequence Diagram figure.

The Quad Enable bit (QE) of Status Register (S9) must be set to enable for the Quad Output Fast Read command.

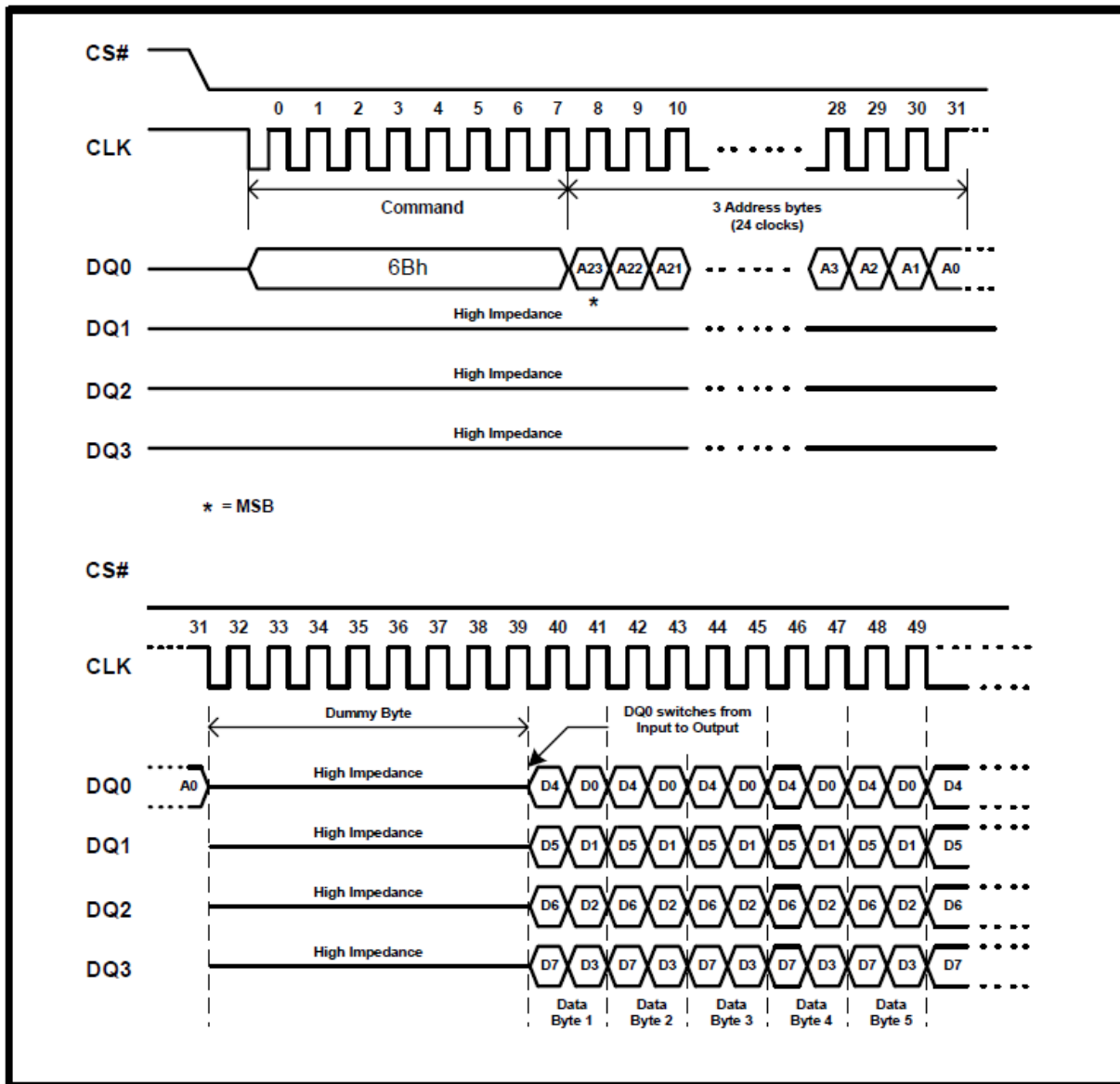

Quad Output Fast Read Instruction Sequence Diagram

Quad Input / Output FAST_READ (EBh)

The Quad Input/Output FAST_READ (EBh) instruction is similar to the Dual I/O Fast Read (BBh) instruction except that address and data bits are input and output through four pins, DQ₀, DQ₁, DQ₂ and DQ₃ and six dummy clocks are required prior to the data output. The Quad I/O dramatically reduces instruction overhead allowing faster random access for code execution (XIP) directly from the Quad SPI.

The Quad Input/Output FAST_READ (EBh) instruction enable quad throughput of Serial Flash in read mode. The address is latching on rising edge of CLK, and data of every four bits (interleave on 4 I/O pins) shift out on the falling edge of CLK at a maximum frequency F_R. The first address can be any location. The address is automatically increased to the next higher address after each byte data is shifted out, so the whole memory can be read out at a single Quad Input/Output FAST_READ instruction. The address counter rolls over to 0 when the highest address has been reached. Once writing Quad Input/Output FAST_READ instruction, the following address/dummy/data out will perform as 4-bit instead of previous 1-bit.

The sequence of issuing Quad Input/Output FAST_READ (EBh) instruction is: CS# goes low -> sending Quad Input/Output FAST_READ (EBh) instruction -> 24-bit address interleave on DQ₃, DQ₂, DQ₁ and DQ₀ -> 6 dummy clocks -> data out interleave on DQ₃, DQ₂, DQ₁ and DQ₀ -> to end Quad Input/Output FAST_READ (EBh) operation can use CS# to high at any time during data out, as shown in Quad Input / Output Fast Read Instruction Sequence Diagram figure.

The Quad Enable bit (QE) of Status Register (S9) must be set to enable for the Quad I/O Fast read command.

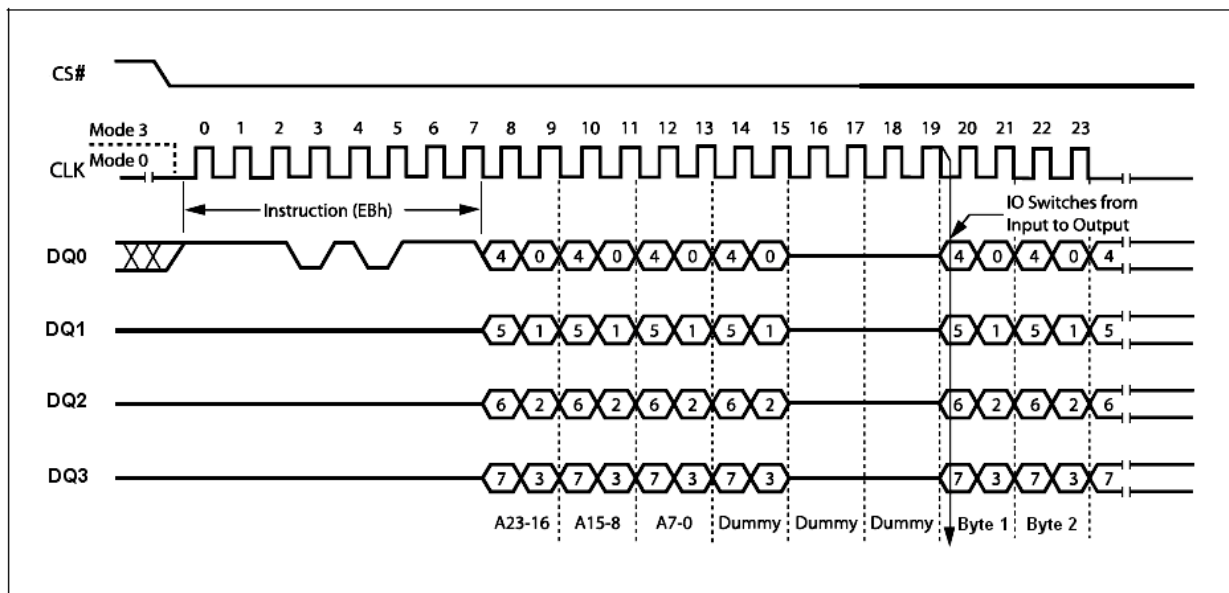

Quad Input / Output Fast Read Instruction Sequence Diagram

Quad I/O Fast Read with “Enhance Read Mod”

Another sequence of issuing Quad Input/Output FAST_READ (EBh) instruction especially useful in random access is : CS# goes low -> sending Quad Input/Output FAST_READ (EBh) instruction -> 24-bit address interleave on DQ₃, DQ₂, DQ₁ and DQ₀ -> Enhance Read Mode bit P[5,4]=(1,0) -> 4 dummy clocks -> data out interleave on DQ₃, DQ₂, DQ₁ and DQ₀ till CS# goes high -> CS# goes low (reduce Quad Input/Output FAST_READ (EBh) instruction) -> 24-bit random access address, as shown in Quad Input/Output Fast Read Enhance Read Mode Sequence Diagram figure.

In the Enhance Read Mode, P[5:4] must be equal to (1, 0) ; likewise P[7:0] = Axh, Exh, can make this mode continue and reduce the next Quad Input/Output FAST_READ (EBh) instruction. Once P[5:4] is no longer equal to (1,0); likewise P[7:0] = FFh, 00h. These commands will reset the enhance read mode.

While Program/ Erase/ Write Status Register is in progress, Quad Input/Output FAST_READ (EBh) instruction is rejected without impact on the Program/ Erase/ Write Status Register current cycle.

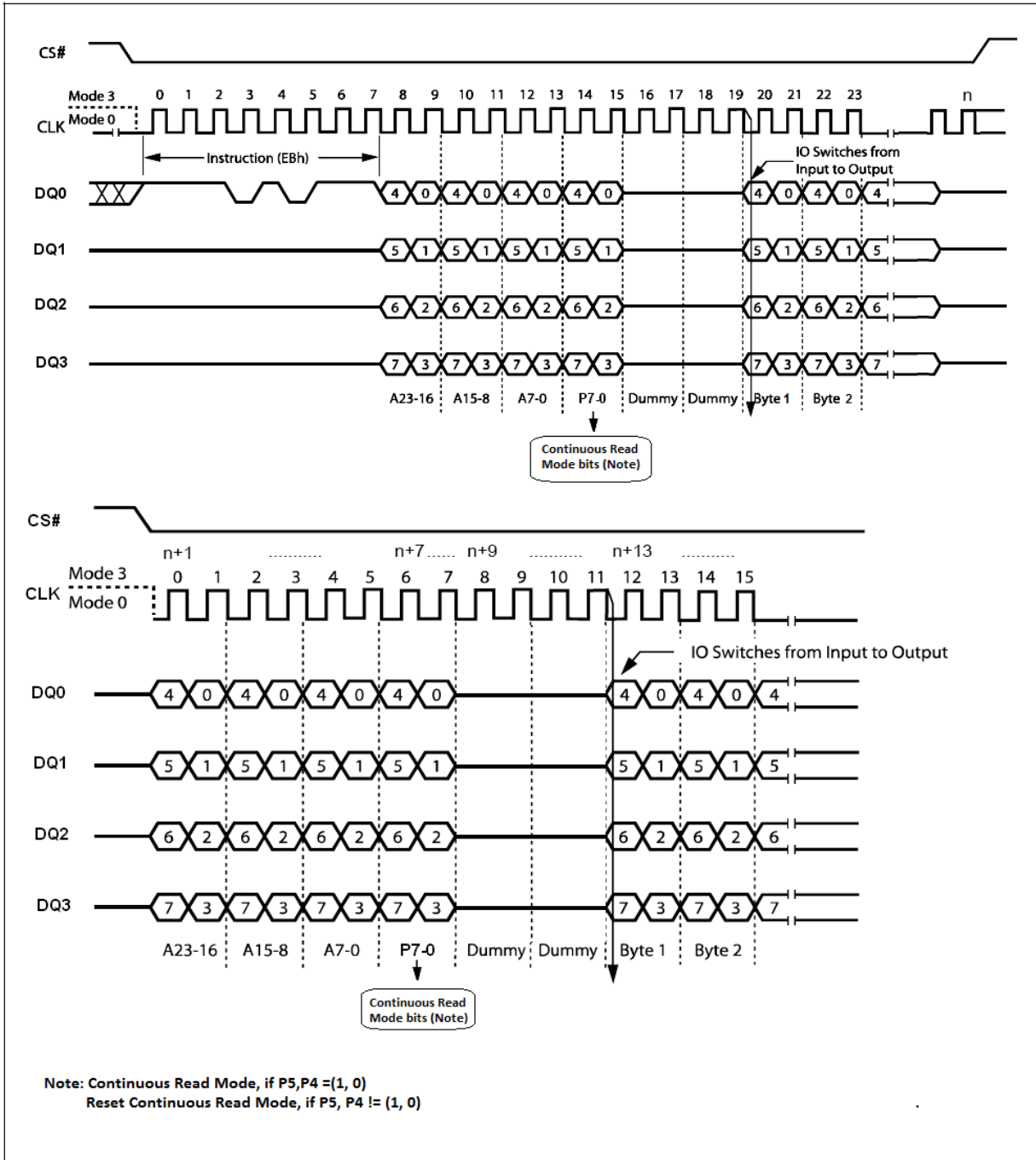

Quad Input / Output Fast Read Enhance Read Mode Sequence Diagram

Quad Input/Output Fast Read with “8/16/32/64 byte Wrap Around”

The Quad I/O Fast Read command can be used to access a specific portion within a page by issuing “Set Burst with Wrap” (77h) commands prior to EBh. The “Set Burst with Wrap” (77h) command can either enable or disable the “Wrap Around” feature for the following EBh commands. When “Wrap Around” is enabled, the data being accessed can be limited to either an 8/16/32/64-byte section of a 256-byte page. The output data starts at the initial address specified in the command, once it reaches the ending boundary of the 8/16/32/64-byte section, the output will wrap around the beginning boundary automatically until CS# is pulled high to terminate the command.

The Burst with Wrap feature allows applications that use cache to quickly fetch a critical address and then fill the cache afterwards within a fixed length (8/16/32/64-byte) of data without issuing multiple read commands. The “Set Burst with Wrap” command allows three “Wrap Bits” W6-W4 to be set. The W4 bit is used to enable or disable the “Wrap Around” operation while W6-W5 is used to specify the length of the wrap around section within a page.

Set Burst with Wrap (77h)

The Set Burst with Wrap command is used in conjunction with “Quad I/O Fast Read (EBh)” command to access a fixed length of 8/16/32/64-byte section within a 256-byte page, in standard SPI mode.

The Set Burst with Wrap command sequence: CS# goes low -> Send Set Burst with Wrap command (77h)-> 24 dummy bits -> 8 bits “Wrap bits” ->CS# goes high. (Set Burst with Wrap Sequence Diagram figure.)

W6, W5	W4=0		W4=1 (default)	
	Wrap Around	Wrap Length	Wrap Around	Wrap Length
0, 0	Yes	8 byte	No	-
0, 1	Yes	16 byte	No	-
1, 0	Yes	32 byte	No	-
1, 1	Yes	64 byte	No	-

If the W6-W4 bits are set by the Set Burst with Wrap (77h) command, all the following “Quad I/O Fast Read (EBh)” command will use the W6-W4 setting to access the 8/16/32/64-byte section within any page. To exit the “Wrap Around” function and return to normal read operation, another Set Burst with Wrap command should be issued to set W4=1.

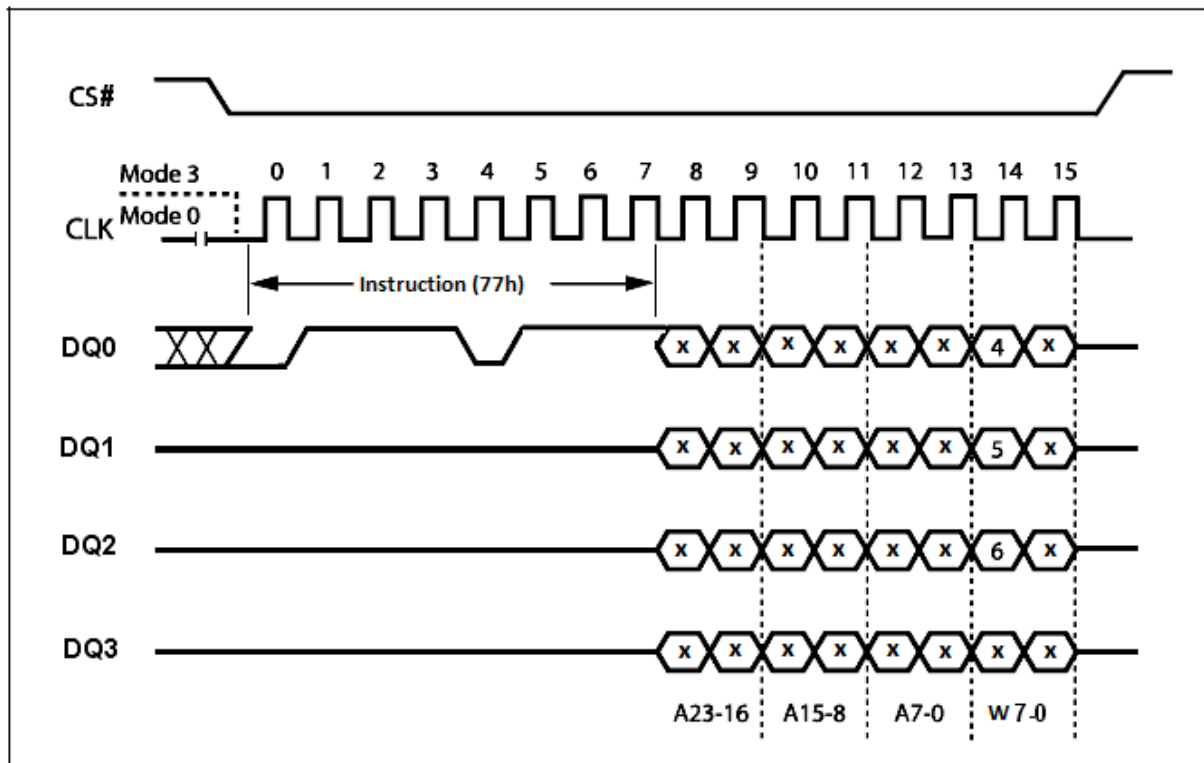
Set Burst with Wrap Sequence Diagram

Page Program (PP) (02h)

The Page Program (PP) instruction allows bytes to be programmed in the memory. Before it can be accepted, a Write Enable (WREN) instruction must previously have been executed. After the Write Enable (WREN) instruction has been decoded, the device sets the Write Enable Latch (WEL).

The Page Program (PP) instruction is entered by driving Chip Select (CS#) Low, followed by the instruction code, three address bytes and at least one data byte on Serial Data Input (DI). If the 8 least significant address bits (A7-A0) are not all zero, all transmitted data that goes beyond the end of the current page are programmed from the start address of the same page (from the address whose 8 least significant bits (A7-A0) are all zero). Chip Select (CS#) must be driven Low for the entire duration of the sequence.

The instruction sequence is shown in Page Program Instruction Sequence Diagram figure. If more than 256 bytes are sent to the device, previously latched data are discarded and the last 256 data bytes are guaranteed to be programmed correctly within the same page. If less than 256 Data bytes are sent to device, they are correctly programmed at the requested addresses without having any effects on the other bytes of the same page.

Chip Select (CS#) must be driven High after the eighth bit of the last data byte has been latched in, otherwise the Page Program (PP) instruction is not executed.

As soon as Chip Select (CS#) is driven high, the self-timed Page Program cycle (whose duration is t_{PP}) is initiated. While the Page Program cycle is in progress, the Status Register may be read to check the value of the Write in Progress (WIP) bit. The Write in Progress (WIP) bit is 1 during the self-timed Page Program cycle, and is 0 when it is completed. At some unspecified time before the cycle is completed, the Write Enable Latch (WEL) bit is reset.

A Page Program (PP) instruction applied to a page which is protected by the Block Protect (CMP, 4KBL, TB, BP2, BP1, BP0) bits (Protected Area Sizes Sector Organization table) is not executed.

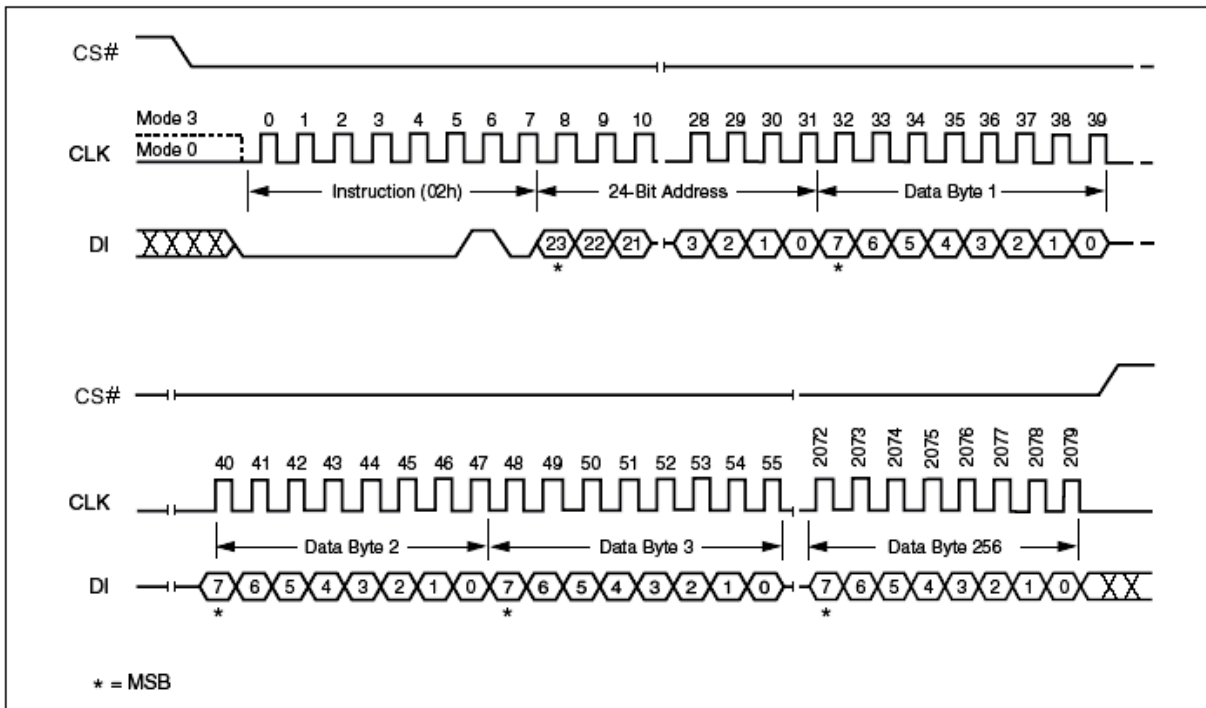

Page Program Instruction Sequence Diagram

Quad Input Page Program (QPP) (32h)

The Quad Page Program (QPP) instruction allows up to 256 bytes of data to be programmed at previously erased (FFh) memory locations using four pins: DQ0, DQ1, DQ2 and DQ3. The Quad Page Program can improve performance for PROM Programmer and applications that have slow clock speeds < 5MHz. Systems with faster clock speed will not realize much benefit for the Quad Page Program instruction since the inherent page program time is much greater than the time it take to clock- in the data.

To use Quad Page Program (QPP) the WP# and HOLD# Disable (QE) bit in Status Register must be set to 1. A Write Enable instruction must be executed before the device will accept the Quad Page Program (QPP) instruction (SR.1, WEL=1). The instruction is initiated by driving the CS# pin low then shifting the instruction code "32h" followed by a 24-bit address (A23-A0) and at least one data byte, into the IO pins. The CS# pin must be held low for the entire length of the instruction while data is being sent to the device. All other functions of Quad Page Program (QPP) are identical to standard Page Program. The Quad Page Program (QPP) instruction sequence is shown in Quad Input Page Program Instruction Sequence Diagram figure.

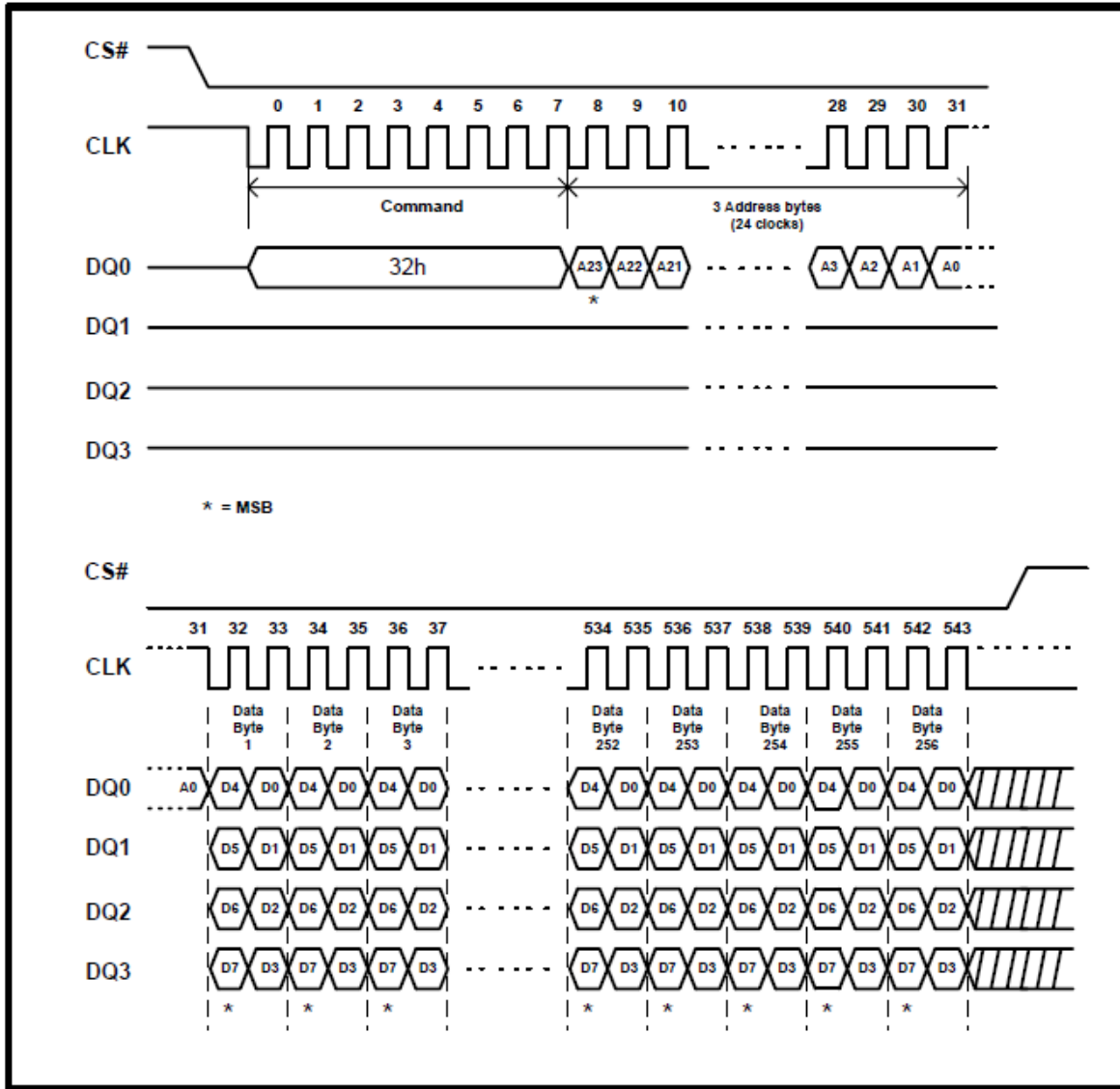

Quad Input Page Program Instruction Sequence Diagram

Write Suspend (75h/B0h)

Write Suspend allows the interruption of Sector Erase, Block Erase or Page Program operations in order to read data in another sector or block of memory. The original operation can be continued with Write Resume command. The instruction sequence is shown in Write Suspend Instruction Sequence Diagram figure.

Only one write operation can be suspended at a time; if an operation is already suspended, the device will ignore the Write Suspend command. Write Suspend during Chip Erase is ignored; Chip Erase is not a valid command while a write is suspended.

Suspend to suspend ready timing: 28 us.

Resume to another suspend timing: min 0.3 us typ 400 us.

Note:

User can use resume to another suspend minimum timing for issue next suspend after resume, but the device needs equal or longer typical time to make other progress after resume command.

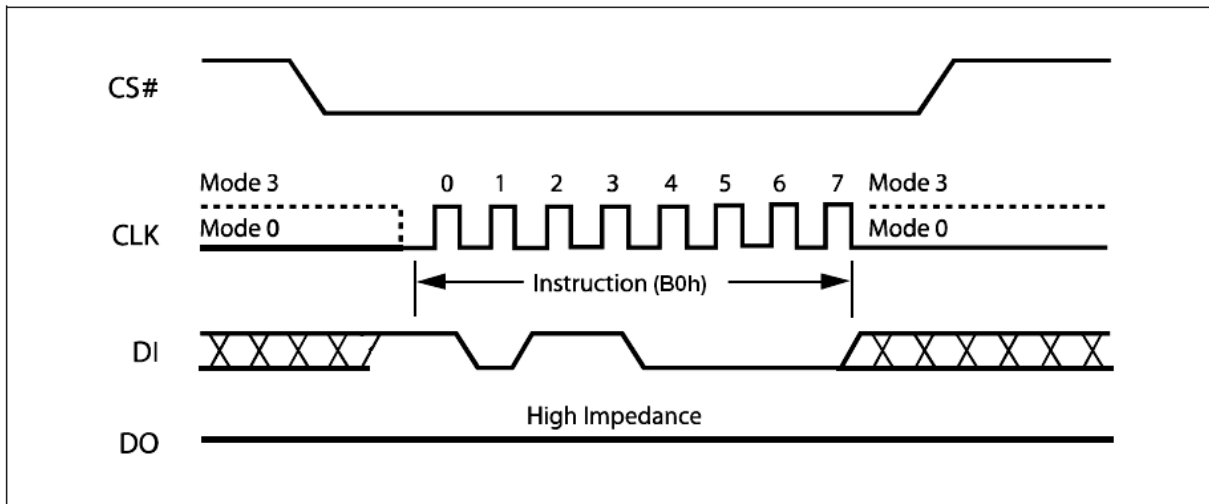

Write Suspend Instruction Sequence Diagram

Write Suspend During Sector Erase or Block Erase

The Write Status Register command (01h, 31h, C0h, 11h) and Erase OTP array command (44h) and Erase commands (20h, 52h, D8h, C7h/60h) are not allowed during Erase suspend.

Issuing a Write Suspend instruction during Erasing allows the host to read any block which is not being erased or to program any block which is not being erased. Program commands pointing to the suspended sector will be ignored. Any attempt to read from the suspended block will output unknown data because the Sector or Block Erase will be incomplete.

To execute a Write Suspend operation, the host drives CS# low, sends the Write Suspend command cycle (B0h), then drives CS# high. A cycle is two nibbles long, most significant nibble first. The Suspend Status register indicates that the erase has been suspended by changing the WSE bit from “0” to “1”, but the device will not accept another command until it is ready. To determine when the device will accept a new command, poll the WIP bit in the Suspend Status register or after issue erase suspend command, latency time 28 us is needed before issue another command. For “Suspend to Read”, “Resume to Read”, “Resume to Suspend” timing specification please note Suspend to Read Latency, Resume to Read Latency and Resume to Suspend Latency figure.

Write Suspend During Page Programming

The Write Status Register command (01h, 31h, C0h, 11h) and Erase/Program OTP array command (44h, 42h) and Erase commands (20h, 52h, D8h, C7h/60h) and Page Program command (02h, 32h) are not allowed during Program suspend.

Issuing a Write Suspend instruction during Page Programming allows the host to read any page which is not being programmed. Erase commands pointing to the suspended sector will be ignored. Any attempt to read from the suspended page will output unknown data because the program will be incomplete.

To execute a Write Suspend operation, the host drives CS# low, sends the Write Suspend command cycle (B0h), then drives CS# high. A cycle is two nibbles long, most significant nibble first. The Suspend Status register indicates that the programming has been suspended by changing the WSP bit from “0” to “1”, but the device will not accept another command until it is ready. To determine when the device will accept a new command, poll the WIP bit in the Suspend Status register or after issue program suspend command, latency time 28 us is needed before issue another command. For “Suspend to Read”, “Resume to Read”, “Resume to Suspend” timing specification please note Suspend to Read Latency, Resume to Read Latency and Resume to Suspend Latency figure.

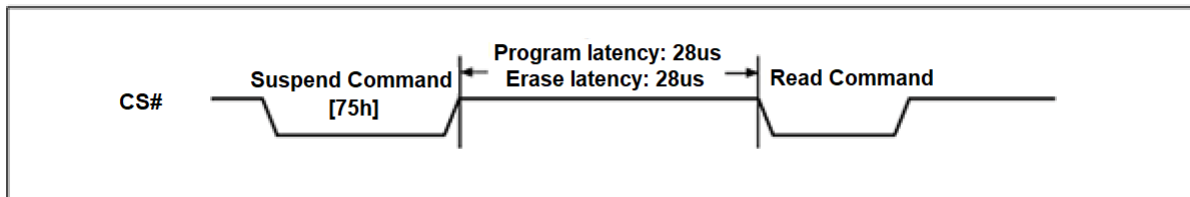

Suspend to Read Latency

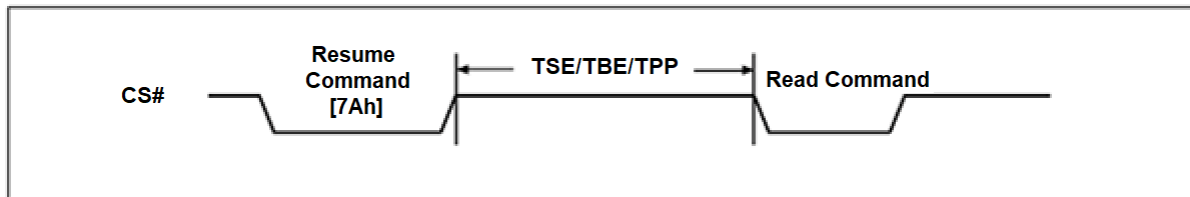

Resume to Read Latency

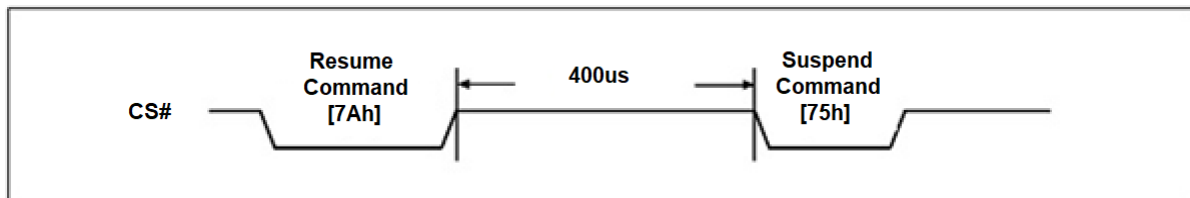

Resume to Suspend Latency

Write Resume (7Ah/30h)

Write Resume restarts a Write command that was suspended, and changes the suspend status bit in the Status Register 2 (WSE or WSP) back to “0”.

The instruction sequence is shown in Write Resume Instruction Sequence Diagram figure. To execute a Write Resume operation, the host drives CS# low, sends the Write Resume command cycle (7Ah/30h), then drives CS# high. A cycle is two nibbles long, most significant nibble first. To determine if the internal, self-timed Write operation completed, poll the WIP bit in the Status Register 2, or wait the specified time t_{SE} , t_{HBE} , t_{BE} or t_{PP} for Sector Erase, Half Block Erase, Block Erase or Page Programming, respectively. The total write time before suspend and after resume will not exceed the uninterrupted write times t_{SE} , t_{HBE} , t_{BE} or t_{PP} . Resume to another suspend operation requires latency time of 400 μ s.

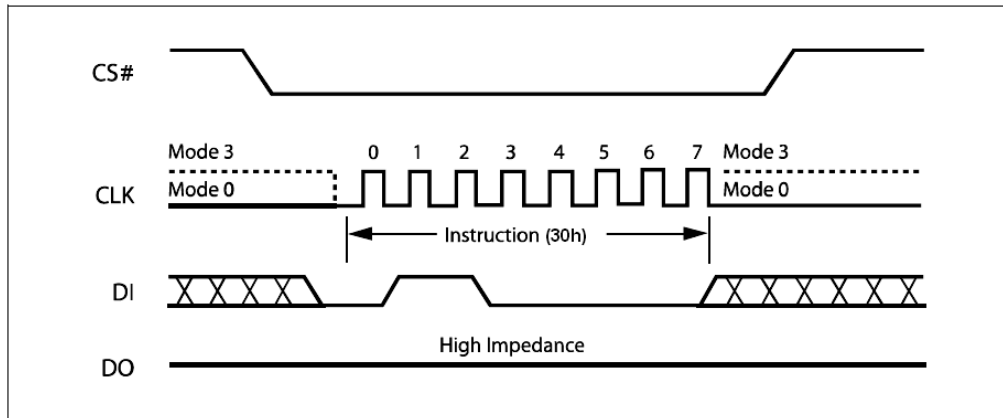

Resume Instruction Sequence Diagram

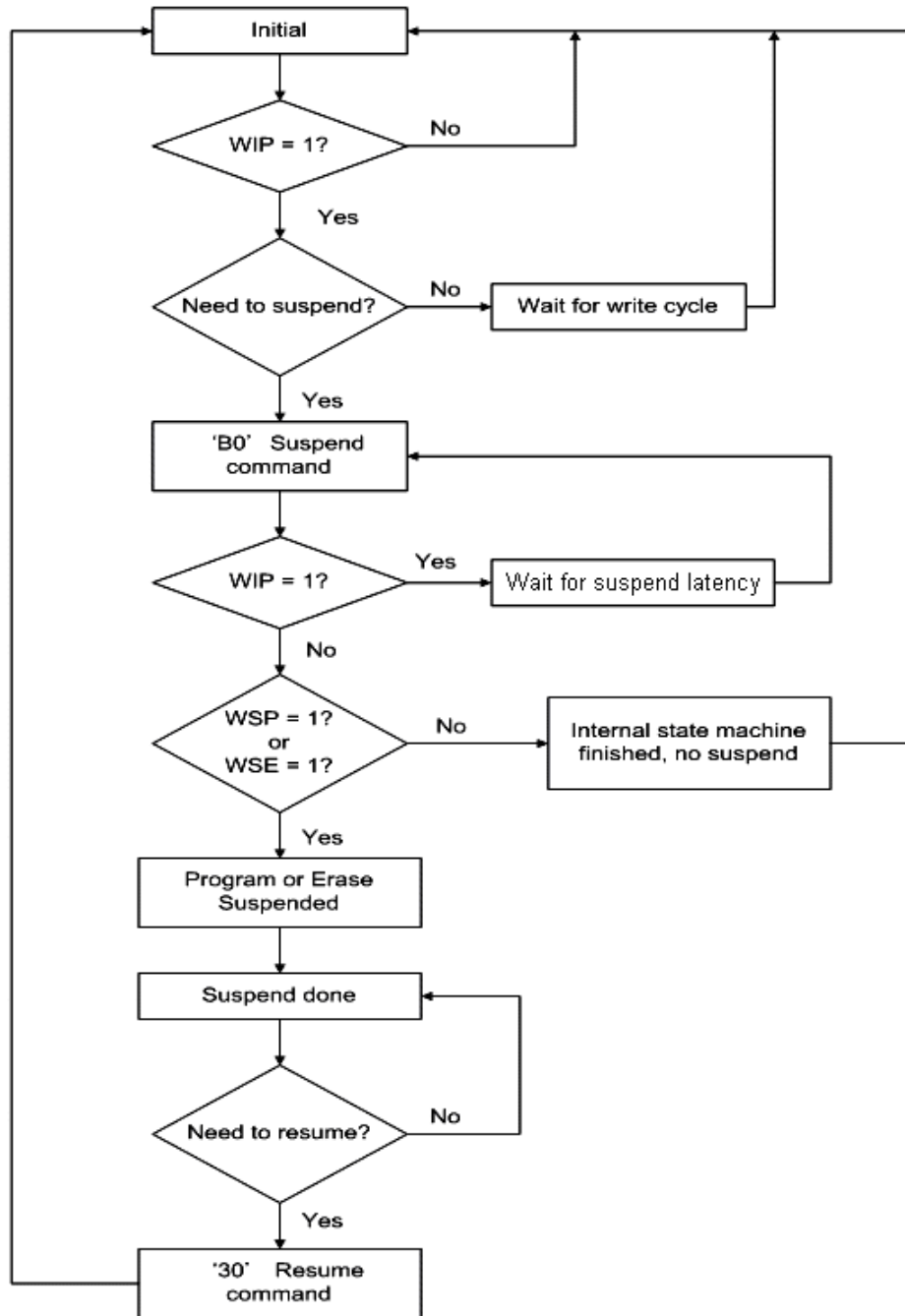
Write Suspend/Resume Flow
Note:

1. The 'WIP' can be either checked by command '05h' polling.
2. 'Wait for write cycle' can be referring to maximum write cycle time or polling the WIP.
3. 'Wait for suspend latency', after issue program suspend command, latency time 28 us is needed before issue another command or polling the WIP.
4. The 'WSP' and 'WSE' can be checked by command '09h/35h' polling.
5. 'Suspend done' means the chip can do further operations allowed by suspend spec.

Sector Erase (SE) (20h)

The Sector Erase (SE) instruction sets to 1 (FFh) all bits inside the chosen sector. Before it can be accepted, a Write Enable (WREN) instruction must previously have been executed. After the Write Enable (WREN) instruction has been decoded, the device sets the Write Enable Latch (WEL).

The Sector Erase (SE) instruction is entered by driving Chip Select (CS#) Low, followed by the instruction code, and three address bytes on Serial Data Input (DI). Any address inside the Sector (see Table 2) is a valid address for the Sector Erase (SE) instruction. Chip Select (CS#) must be driven Low for the entire duration of the sequence.

The instruction sequence is shown in Sector Erase Instruction Sequence Diagram figure. Chip Select (CS#) must be driven High after the eighth bit of the last address byte has been latched in, otherwise the Sector Erase (SE) instruction is not executed. As soon as Chip Select (CS#) is driven High, the self-timed Sector Erase cycle (whose duration is t_{SE}) is initiated. While the Sector Erase cycle is in progress, the Status Register may be read to check the value of the Write in Progress (WIP) bit. The Write in Progress (WIP) bit is 1 during the self-timed Sector Erase cycle, and is 0 when it is completed. At some unspecified time before the cycle is completed, the Write Enable Latch (WEL) bit is reset.

A Sector Erase (SE) instruction applied to a sector which is protected by the Block Protect (CMP, 4KBL, TB, BP2, BP1, BP0) bits (see Table 3) or Boot Lock feature will be ignored.

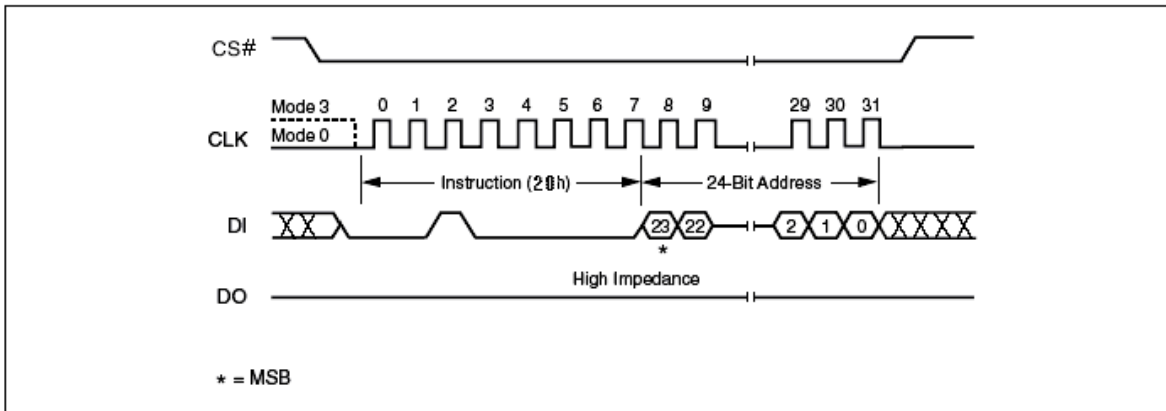

Sector Erase Instruction Sequence Diagram

32KB Half Block Erase (HBE) (52h)

The Half Block Erase (HBE) instruction sets to 1 (FFh) all bits inside the chosen block. Before it can be accepted, a Write Enable (WREN) instruction must previously have been executed. After the Write Enable (WREN) instruction has been decoded, the device sets the Write Enable Latch (WEL).

The Half Block Erase (HBE) instruction is entered by driving Chip Select (CS#) Low, followed by the instruction code, and three address bytes on Serial Data Input (DI). Any address inside the Block (see Table 2) is a valid address for the Half Block Erase (HBE) instruction. Chip Select (CS#) must be driven Low for the entire duration of the sequence.

The instruction sequence is shown in 32KB Half Block Erase Instruction Sequence Diagram figure. Chip Select (CS#) must be driven High after the eighth bit of the last address byte has been latched in, otherwise the Half Block Erase (HBE) instruction is not executed. As soon as Chip Select (CS#) is driven High, the self-timed Block Erase cycle (whose duration is t_{HBE}) is initiated. While the Half Block Erase cycle is in progress, the Status Register may be read to check the value of the Write in Progress (WIP) bit. The Write in Progress (WIP) bit is 1 during the self-timed Half Block Erase cycle, and is 0 when it is completed. At some unspecified time before the cycle is completed, the Write Enable Latch (WEL) bit is reset.

A Half Block Erase (HBE) instruction applied to a block which is protected by the Block Protect (CMP, 4KBL, TB, BP2, BP1, BP0) bits (see Protected Area Sizes Sector Organization table).

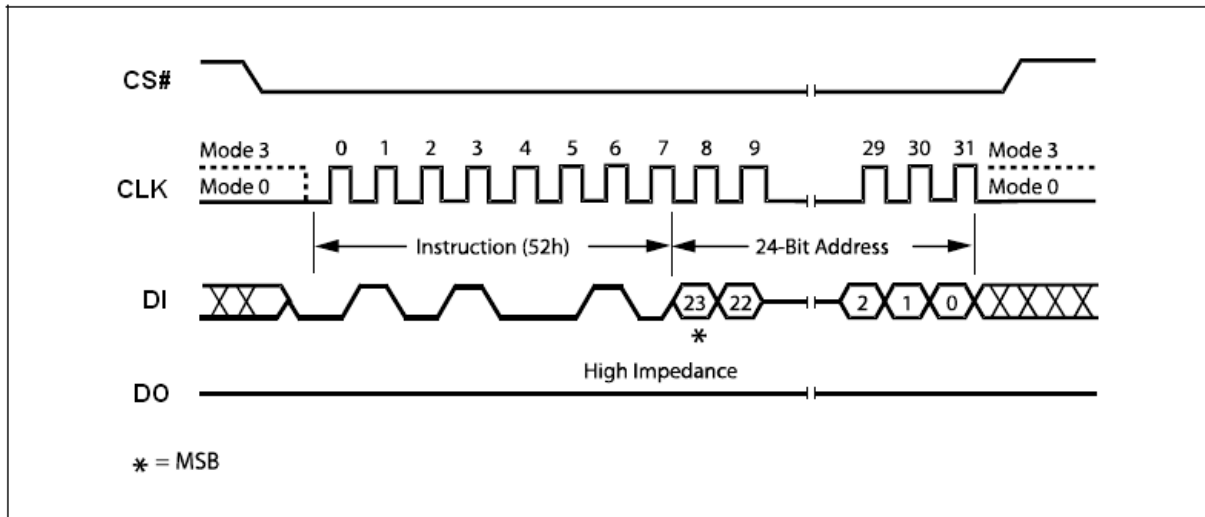
32KB Half Block Erase Instruction Sequence Diagram

64KB Block Erase (BE) (D8h)

The Block Erase (BE) instruction sets to 1 (FFh) all bits inside the chosen block. Before it can be accepted, a Write Enable (WREN) instruction must previously have been executed. After the Write Enable (WREN) instruction has been decoded, the device sets the Write Enable Latch (WEL).

The Block Erase (BE) instruction is entered by driving Chip Select (CS#) Low, followed by the instruction code, and three address bytes on Serial Data Input (DI). Any address inside the Block (see Uniform Block Sector Architecture table) is a valid address for the Block Erase (BE) instruction. Chip Select (CS#) must be driven Low for the entire duration of the sequence.

The instruction sequence is shown in Figure 33. Chip Select (CS#) must be driven High after the eighth bit of the last address byte has been latched in, otherwise the Block Erase (BE) instruction is not executed. As soon as Chip Select (CS#) is driven High, the self-timed Block Erase cycle (whose duration is t_{BE}) is initiated. While the Block Erase cycle is in progress, the Status Register may be read to check the value of the Write in Progress (WIP) bit. The Write in Progress (WIP) bit is 1 during the self-timed Block Erase cycle, and is 0 when it is completed. At some unspecified time before the cycle is completed, the Write Enable Latch (WEL) bit is reset.

A Block Erase (BE) instruction applied to a block which is protected by the Block Protect (CMP, 4KBL, TB, BP2, BP1, BP0) bits (see Protected Area Sizes Sector Organization table).

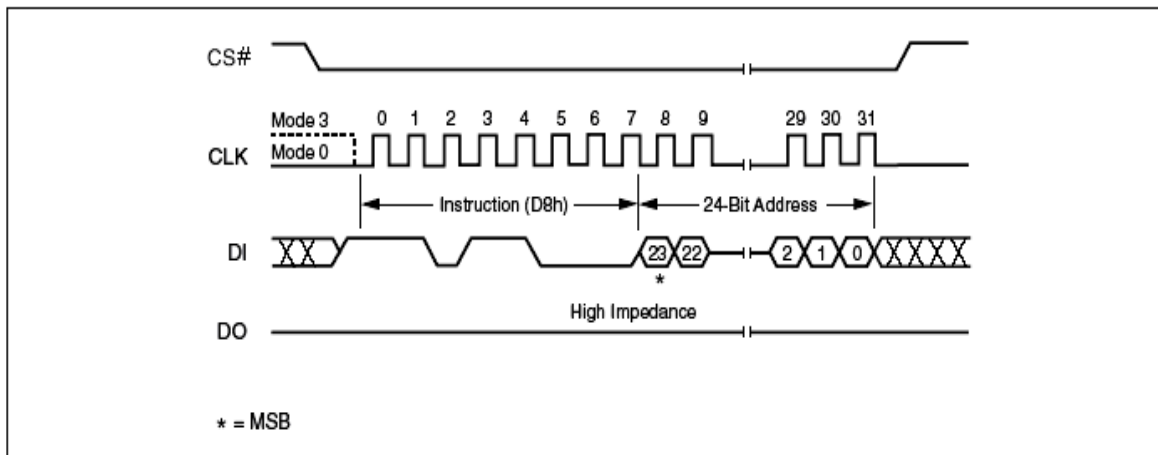

64KB Block Erase Instruction Sequence Diagram

Chip Erase (CE) (C7h/60h)

The Chip Erase (CE) instruction sets all bits to 1 (FFh). Before it can be accepted, a Write Enable (WREN) instruction must previously have been executed. After the Write Enable (WREN) instruction has been decoded, the device sets the Write Enable Latch (WEL).

The Chip Erase (CE) instruction is entered by driving Chip Select (CS#) Low, followed by the instruction code on Serial Data Input (DI). Chip Select (CS#) must be driven Low for the entire duration of the sequence.

The instruction sequence is shown in Chip Erase Instruction Sequence Diagram figure. Chip Select (CS#) must be driven High after the eighth bit of the instruction code has been latched in, otherwise the Chip Erase instruction is not executed. As soon as Chip Select (CS#) is driven High, the self-timed Chip Erase cycle (whose duration is t_{CE}) is initiated. While the Chip Erase cycle is in progress, the Status Register may be read to check the value of the Write in Progress (WIP) bit. The Write in Progress (WIP) bit is 1 during the self-timed Chip Erase cycle, and is 0 when it is completed. At some unspecified time before the cycle is completed, the Write Enable Latch (WEL) bit is reset.

The Chip Erase (CE) instruction is ignored if one or more blocks are protected.

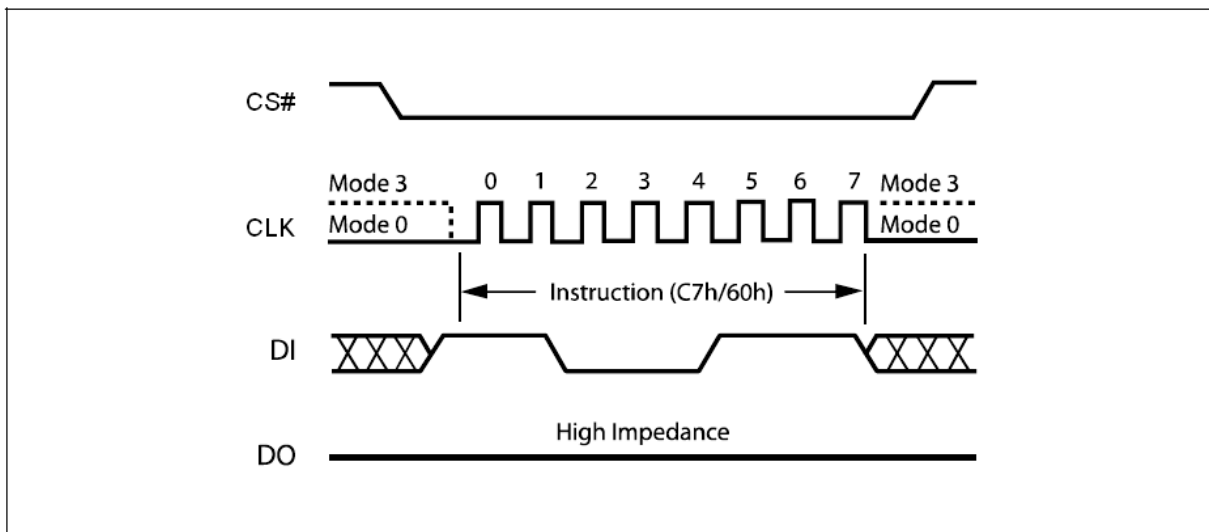

Chip Erase Instruction Sequence Diagram

Deep Power-down (DP) (B9h)

Executing the Deep Power-down (DP) instruction is the only way to put the device in the lowest consumption mode (the Deep Power-down mode). It can also be used as an extra software protection mechanism, while the device is not in active use, since in this mode, the device ignores all Write, Program and Erase instructions.

Driving Chip Select (CS#) High deselects the device, and puts the device in the Standby mode (if there is no internal cycle currently in progress). But this mode is not the Deep Power-down mode. The Deep Power-down mode can only be entered by executing the Deep Power-down (DP) instruction, to reduce the standby current (from I_{CC1} to I_{CC2} , as specified in DC Characteristics table.)

Once the device has entered the Deep Power-down mode, all instructions are ignored except the Release from Deep Power-down, Read Device ID (RDI) or Software Reset instruction which release the device from this mode. The Release from Deep Power-down and Read Device ID (RDI) instruction also allows the Device ID of the device to be output on Serial Data Output (DO).

The Deep Power-down mode automatically stops at Power-down, and the device always Powers-up in the Standby mode. The Deep Power-down (DP) instruction is entered by driving Chip Select (CS#) Low, followed by the instruction code on Serial Data Input (DI). Chip Select (CS#) must be driven Low for the entire duration of the sequence.

The instruction sequence is shown in Deep Power-down Instruction Sequence Diagram figure. Chip Select (CS#) must be driven High after the eighth bit of the instruction code has been latched in, otherwise the Deep Power-down (DP) instruction is not executed. As soon as Chip Select (CS#) is driven High, it requires a delay of t_{DP} before the supply current is reduced to I_{CC2} and the Deep Power-down mode is entered.

Any Deep Power-down (DP) instruction, while an Erase, Program or Write cycle is in progress, is rejected without having any effects on the cycle that is in progress.

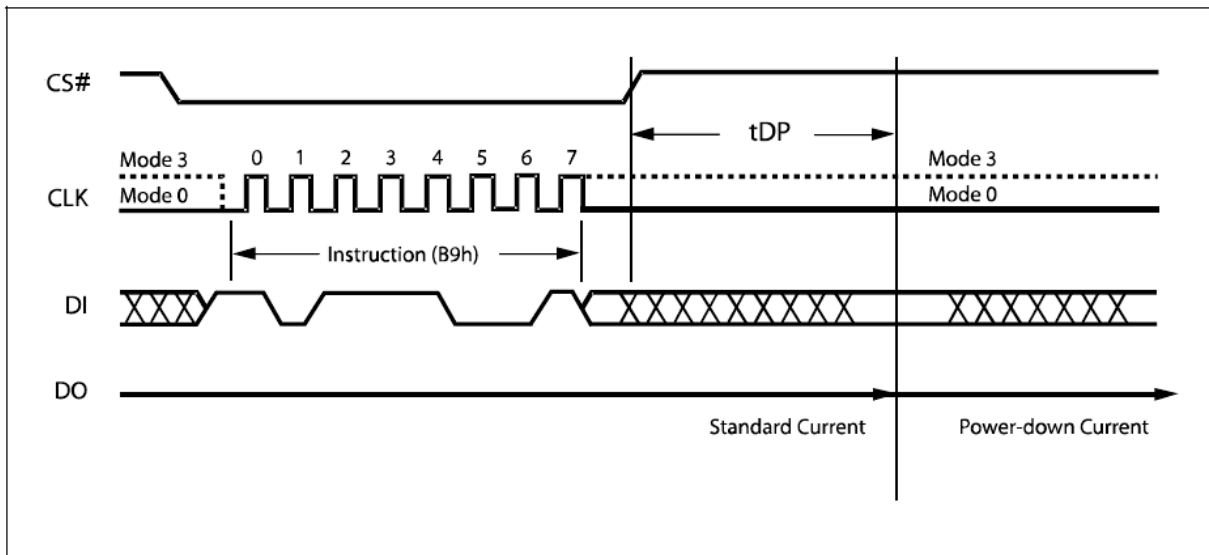

Deep Power-down Instruction Sequence Diagram

Release from Deep Power-down and Read Device ID (RDI)

Once the device has entered the Deep Power-down mode, all instructions are ignored except the Release from Deep Power-down and Read Device ID (RDI) instruction. Executing this instruction takes the device out of the Deep Power-down mode.

Please note that this is not the same as, or even a subset of, the JEDEC 16-bit Electronic Signature that is read by the Read Identifier (RDID) instruction. The old-style Electronic Signature is supported for reasons of backward compatibility, only, and should not be used for new designs. New designs should, instead, make use of the JEDEC 16-bit Electronic Signature, and the Read Identifier (RDID) instruction.

When used only to release the device from the power-down state, the instruction is issued by driving the CS# pin low, shifting the instruction code “ABh” and driving CS# high as shown in Release Power-down Instruction Sequence Diagram figure. After the time duration of t_{RES1} (See AC Characteristics) the device will resume normal operation and other instructions will be accepted. The CS# pin must remain high during the t_{RES1} time duration.

When used only to obtain the Device ID while not in the power-down state, the instruction is initiated by driving the CS# pin low and shifting the instruction code “ABh” followed by 3-dummy bytes. The Device ID bits are then shifted out on the falling edge of CLK with most significant bit (MSB) first as shown in Release Power-down / Device ID Instruction Sequence Diagram figure. The Device ID value for the device is listed in Table 5. The Device ID can be read continuously. The instruction is completed by driving CS# high.

When Chip Select (CS#) is driven High, the device is put in the Stand-by Power mode. If the device was not previously in the Deep Power-down mode, the transition to the Stand-by Power mode is immediate. If the device was previously in the Deep Power-down mode, though, the transition to the Standby Power mode is delayed by t_{RES2} , and Chip Select (CS#) must remain High for at least t_{RES2} (max), as specified in AC Characteristics table. Once in the Stand-by Power mode, the device waits to be selected, so that it can receive, decode and execute instructions.

Except while an Erase, Program or Write Status Register cycle is in progress, the Release from Deep Power-down and Read Device ID (RDI) instruction always provides access to the 8bit Device ID of the device, and can be applied even if the Deep Power-down mode has not been entered.

Any Release from Deep Power-down and Read Device ID (RDI) instruction while an Erase, Program or Write Status Register cycle is in progress, is not decoded, and has no effect on the cycle that is in progress.

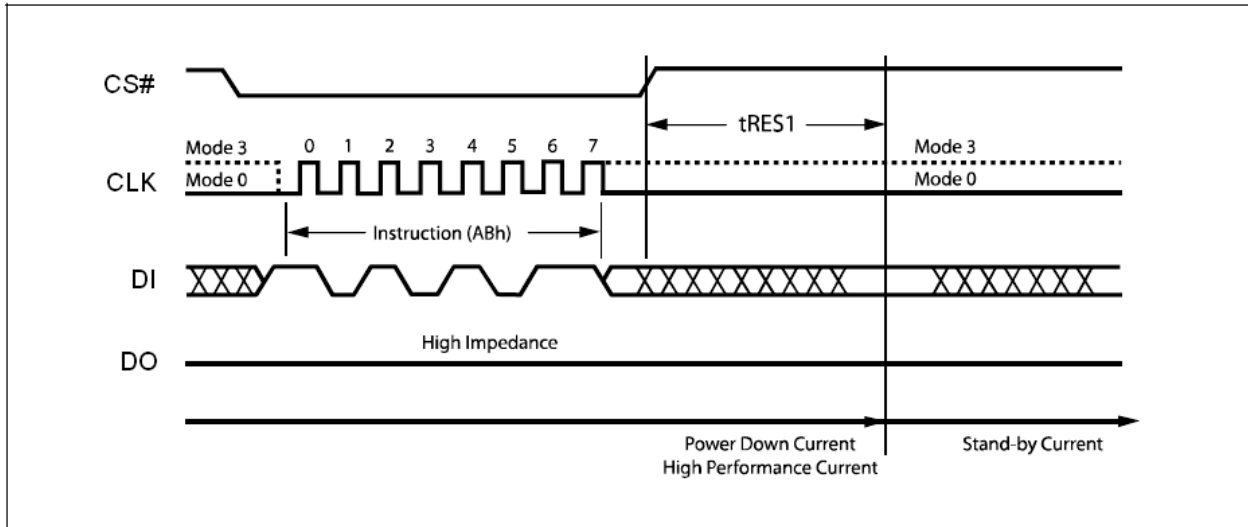

Release Power-down Instruction Sequence Diagram

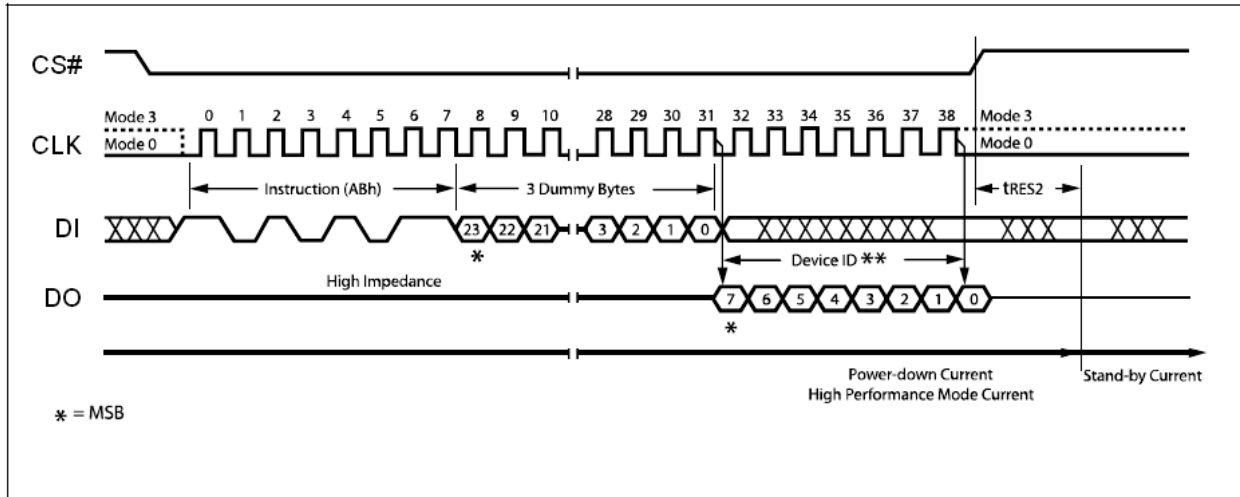

Release Power-down / Device ID Instruction Sequence Diagram

Read Manufacturer / Device ID (90h)

The Read Manufacturer/Device ID instruction is an alternative to the Release from Power-down / Device ID instruction that provides both the JEDEC assigned manufacturer ID and the specific device ID.

The Read Manufacturer/Device ID instruction is very similar to the Release from Power-down / Device ID instruction. The instruction is initiated by driving the CS# pin low and shifting the instruction code “90h” followed by a 24-bit address (A23-A0) of 000000h. After which, the Manufacturer ID for Eon (1Ch) and the Device ID are shifted out on the falling edge of CLK with most significant bit (MSB) first as shown in Read Manufacturer / Device ID Diagram figure. The Device ID values for the device are listed in Manufacturer and Device Identification table. If the 24-bit address is initially set to 000001h the Device ID will be read first

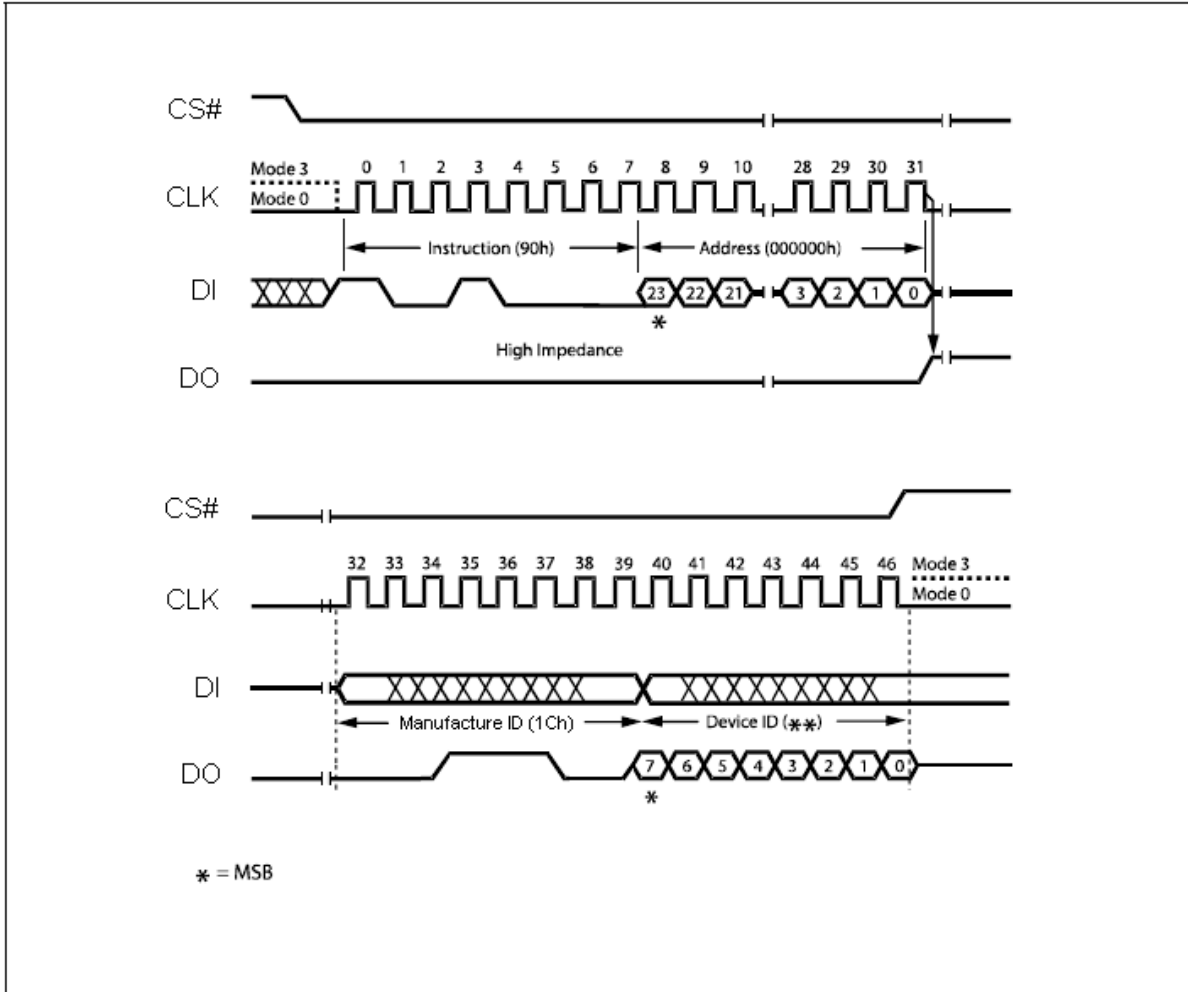

Read Manufacturer / Device ID Diagram

Read Identification (RDID) (9Fh)

The Read Identification (RDID) instruction allows the 8-bit manufacturer identification to be read, followed by two bytes of device identification. The device identification indicates the memory type in the first byte, and the memory capacity of the device in the second byte.

Any Read Identification (RDID) instruction while an Erase or Program cycle is in progress, is not decoded, and has no effect on the cycle that is in progress. The Read Identification (RDID) instruction should not be issued while the device is in Deep Power down mode.

The device is first selected by driving Chip Select Low. Then, the 8-bit instruction code for the instruction is shifted in. This is followed by the 24-bit device identification, stored in the memory, being shifted out on Serial Data Output, each bit being shifted out during the falling edge of Serial Clock. The instruction sequence is shown in Read Identification (RDID) figure. The Read Identification (RDID) instruction is terminated by driving Chip Select High at any time during data output.

When Chip Select is driven High, the device is put in the Standby Power mode. Once in the Standby Power mode, the device waits to be selected, so that it can receive, decode and execute instructions.

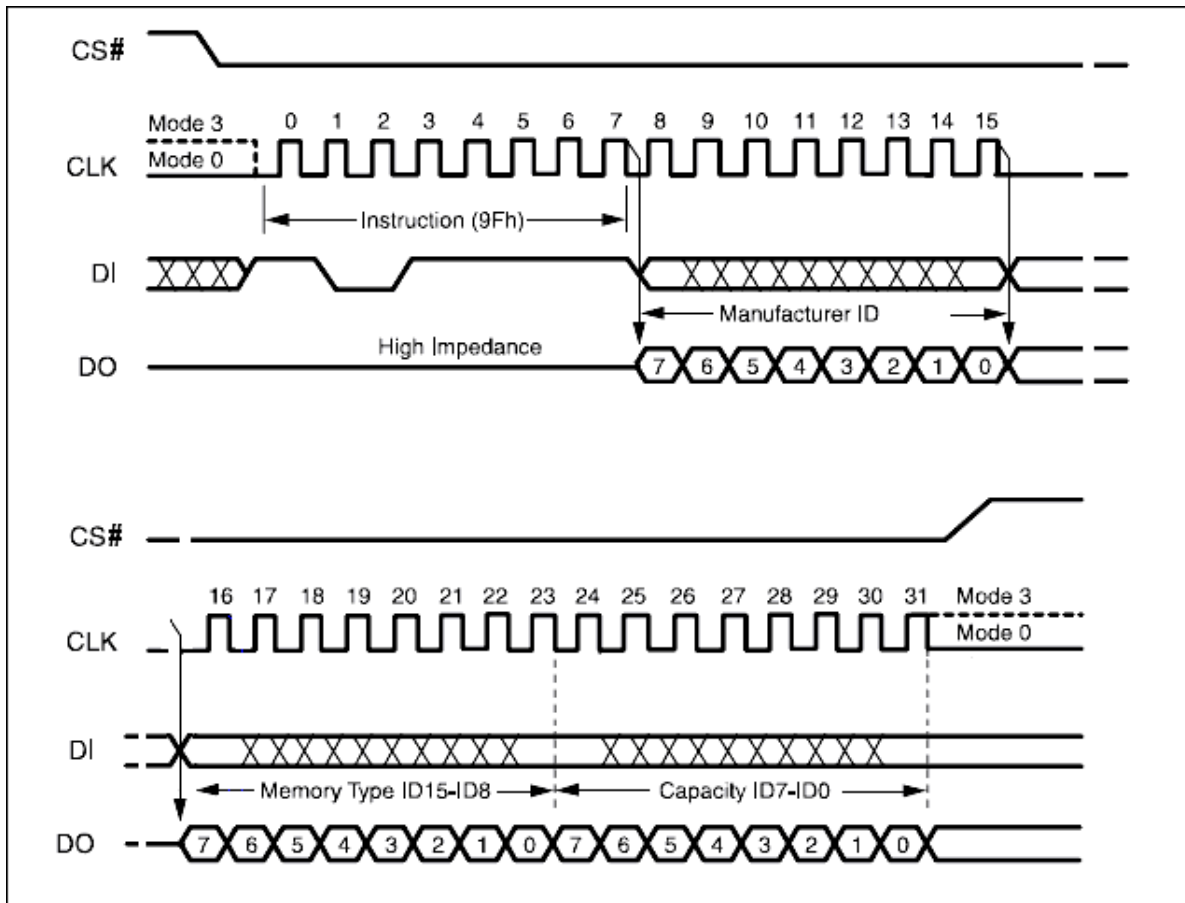
Read Identification (RDID)

Program OTP array (42h)

The Program OTP array operation is similar to the Page Program instruction. It allows from one byte to 256 bytes of security register data to be programmed at previously erased (FFh) memory locations. A Write Enable instruction must be executed before the device will accept the Program OTP array Instruction. The instruction is initiated by driving the CS# pin low then shifting the instruction code “42h” followed by a 24-bit address (A23-A0) and at least one data byte, into the DI pin. The CS# pin must be held low for the entire length of the instruction while data is being sent to the device.

The Program OTP array instruction sequence is shown in Program OTP array figure. The OTP array Lock Bits (SPL0-SPL3) in Status Register2 can be used to OTP protect the OTP array data. Once a lock bit is set to 1, the corresponding OTP array will be permanently locked, Program OTP array instruction to that register will be ignored.

OTP Sector Address

Lock bit	Sector	Sector Size	Address Range
SPL0	511	1024 byte	1FF000h – 1FF3FFh
SPL1	510	1024 byte	1FE000h – 1FE3FFh
SPL2	509	1024 byte	1FD000h – 1FD3FFh

Note: The OTP sector is mapping to sector 511, 510 and 509

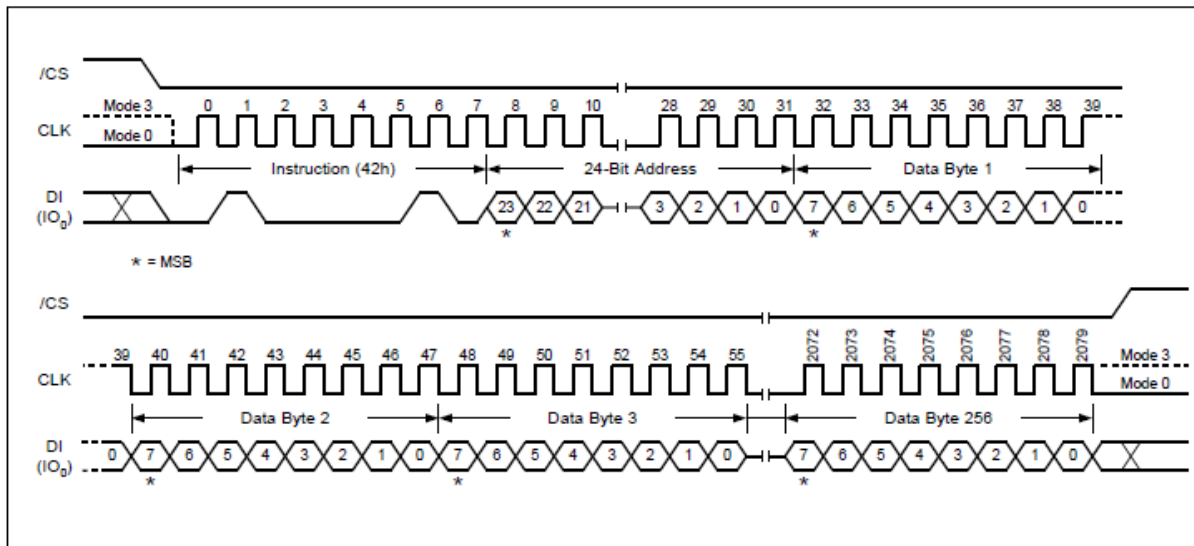

Program OTP array

Read OTP array (48h)

The Read OTP array instruction is similar to the Fast Read instruction and allows one or more data bytes to be sequentially read from one of the three OTP array. The instruction is initiated by driving the CS# pin low and then shifting the instruction code “48h” followed by a 24-bit address (A23-A0) and eight “dummy” clocks into the DI pin.

The code and address bits are latched on the rising edge of the CLK pin. After the address is received, the data byte of the addressed memory location will be shifted out on the DO pin at the falling edge of CLK with most significant bit (MSB) first. The byte address is automatically incremented to the next byte address after each byte of data is shifted out. Once the byte address reaches the last byte of the register (byte address FFh), it will reset to address 00h, the first byte of the register, and continue to increment. The instruction is completed by driving CS# high. The Read OTP array instruction sequence is shown in Read OTP array figure. If a Read OTP array instruction is issued while an Erase, Program or Write cycle is in process (WIP=1) the instruction is ignored and will not have any effects on the current cycle. The Read OTP array instruction allows clock rates from D.C. to a maximum of F_R (see AC Electrical Characteristics).

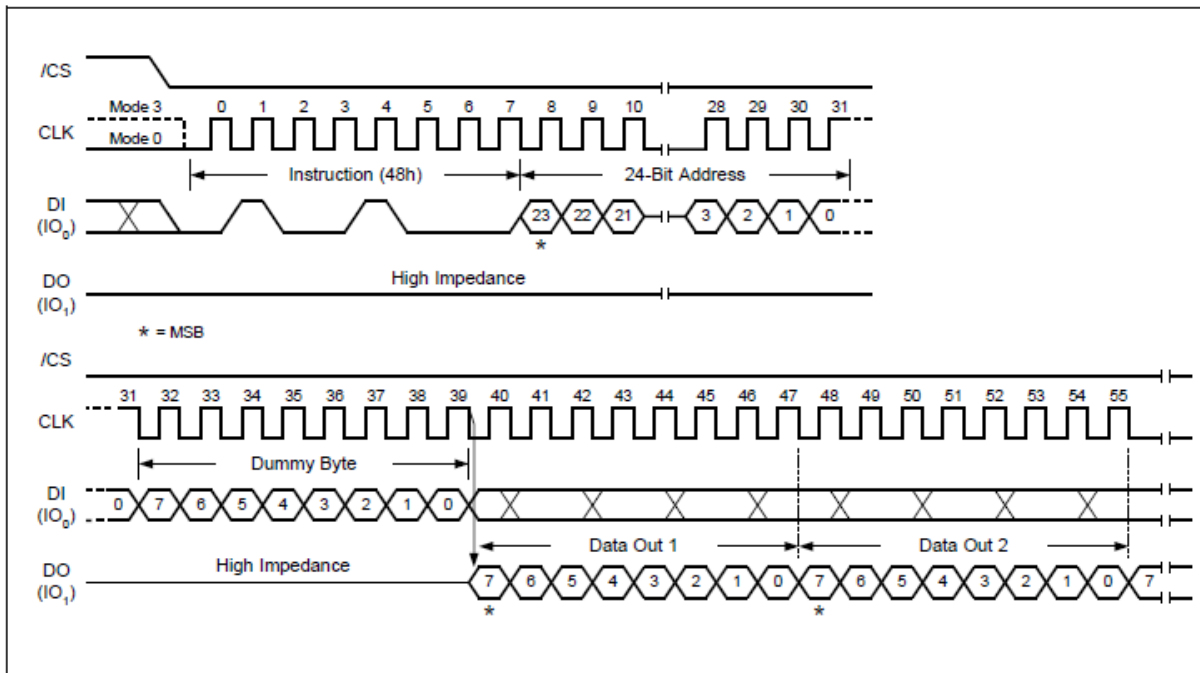

Read OTP array

Erase OTP array (44h)

The device offers three set of 3x1024byte OTP array which can be erased and programmed individually. These registers may be used by the system manufacturers to store security and other important information separately from the main memory array.

The Erase OTP array instruction is similar to the Sector Erase instruction. A Write Enable instruction must be executed before the device will accept the Erase OTP array Instruction (Status Register bit WEL must equal 1). The instruction is initiated by driving the CS# pin low and shifting the instruction code “44h” followed by a 24-bit address (A23-A0) to erase one of the three security registers.

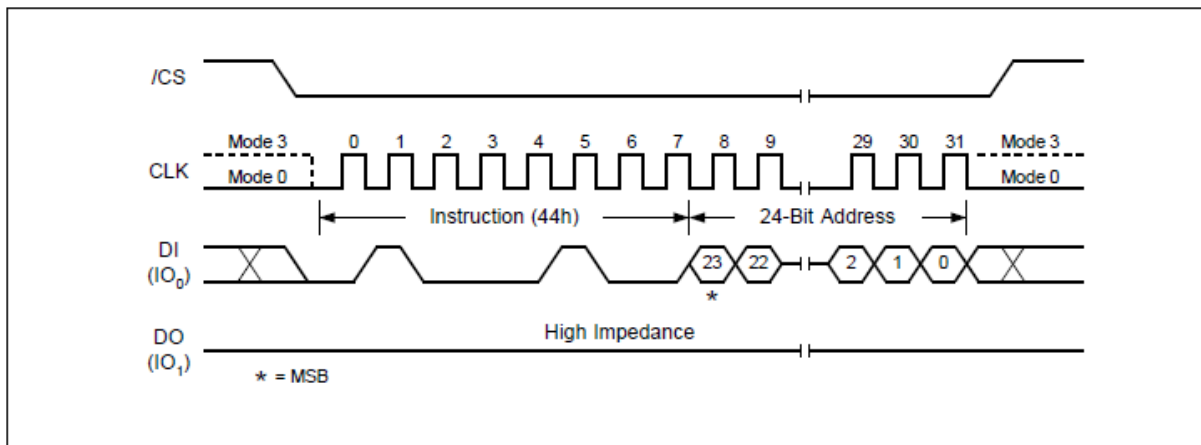
The Erase OTP array instruction sequence is shown in Erase OTP array figure. The CS# pin must be driven high after the eighth bit of the last byte of the instruction has been latched. If this is not done the instruction will not be executed. After CS# is driven high, the self-timed Erase OTP array operation will commence for a time duration of t_{SE} (See AC Characteristics). While the Erase OTP array cycle is in progress, the Read Status Register instruction may still be accessed for checking the status of the WIP bit. The WIP bit is a 1 during the erase cycle and becomes a 0 when the cycle is finished and the device is ready to accept other instructions again. After the Erase OTP array cycle has finished the Write Enable Latch (WEL) bit in the Status Register is cleared to 0. The Security Register Lock Bits (SPL0-3) in the Status Register-2 can be used to OTP protect the security registers. Once a lock bit is set to 1, the corresponding security register will be permanently locked, Erase OTP array instruction to that register will be ignored.



Erase OTP array

Read SFDP Mode (5Ah)

Device features Serial Flash Discoverable Parameters (SFDP) mode. Host system can retrieve the operating characteristics, structure and vendor specified information such as identifying information, memory size, operating voltage and timing information of this device by SFDP mode.

The device is first selected by driving Chip Select (CS#) Low. The instruction code for the Read SFDP Mode is followed by a 3-byte address (A23-A0) and a dummy byte, each bit being latched-in during the rising edge of Serial Clock (CLK). Then the memory contents, at that address, is shifted out on Serial Data Output (DO), each bit being shifted out, at a maximum frequency F_R , during the falling edge of Serial Clock (CLK).

The instruction sequence is shown in Read SFDP Mode and Unique ID Number Instruction Sequence Diagram figure. The first byte addressed can be at any location. The address is automatically incremented to the next higher address after each byte of data is shifted out. The whole memory can, therefore, be read with a single Serial Flash Discoverable Parameters (SFDP) instruction. When the highest address is reached, the address counter rolls over to 0x00h, allowing the read sequence to be continued indefinitely. The Serial Flash Discoverable Parameters (SFDP) instruction is terminated by driving Chip Select (CS#) High. Chip Select (CS#) can be driven High at any time during data output. Any Read Data Bytes at Serial Flash Discoverable Parameters (SFDP) instruction, while an Erase, Program or Write cycle is in progress, is rejected without having any effects on the cycle that is in progress.

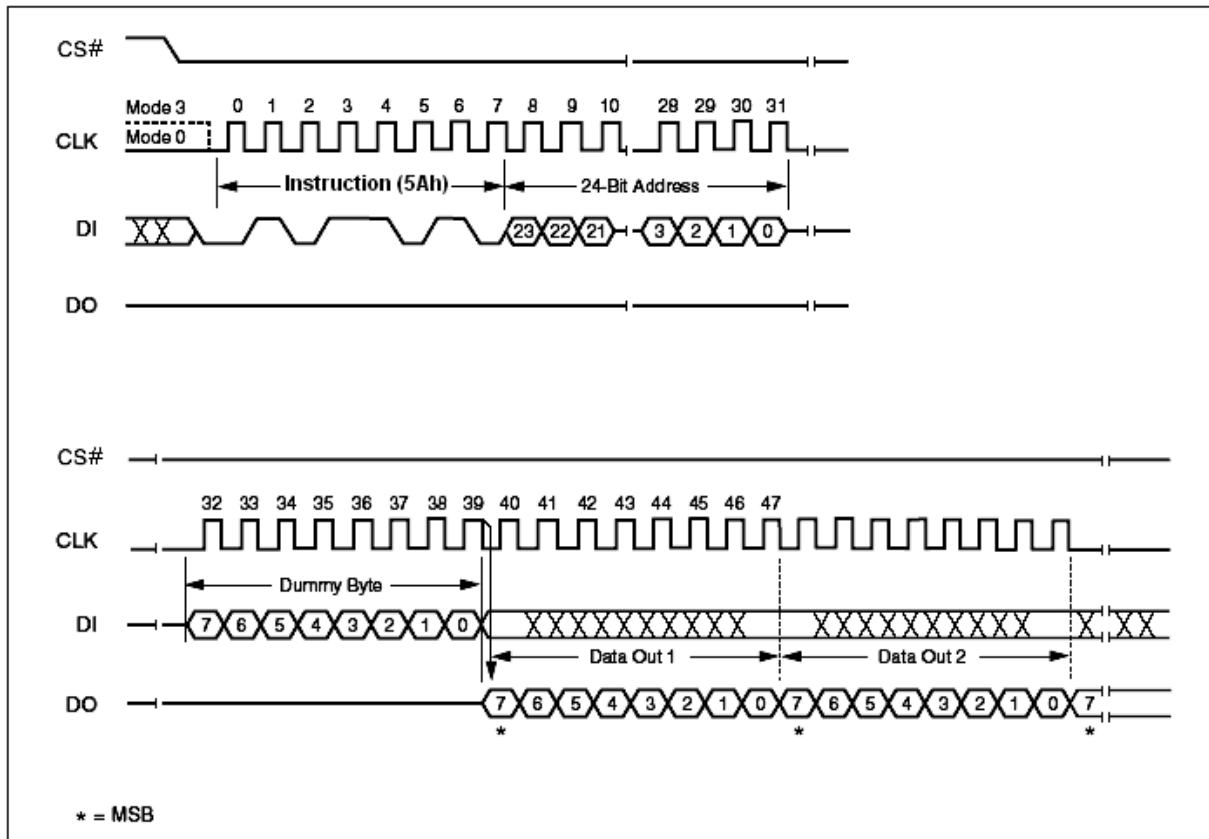

Read SFDP Mode and Unique ID Number Instruction Sequence Diagram

**Serial Flash Discoverable Parameters (SFDP) Signature and Parameter Identification Data Value
(Advanced Information)**

Description	Address (h) (Byte Mode)	Address (Bit)	Data (h)	Comment
SFDP Signature	00h	07 : 00	53h	Signature [31:0]: Hex: 50444653
	01h	15 : 08	46h	
	02h	23 : 16	44h	
	03h	31 : 24	50h	
SFDP Minor Revision Number	04h	07 : 00	00h	Star from 0x00
SFDP Major Revision Number	05h	15 : 08	01h	Star from 0x01
Number of Parameter Headers (NPH)	06h	23 : 16	00h	1 parameter header
Unused	07h	31 : 24	FFh	Reserved
ID Number	08h	07 : 00	00h	JEDEC ID
Parameter Table Minor Revision Number	09h	15 : 08	00h	Star from 0x00
Parameter Table Major Revision Number	0Ah	23 : 16	01h	Star from 0x01
Parameter Table Length (in DW)	0Bh	31 : 24	09h	9 DWORDs
Parameter Table Pointer (PTP)	0Ch	07 : 00	30h	000030h
	0Dh	15 : 08	00h	
	0Eh	23 : 16	00h	
Unused	0Fh	31 : 24	FFh	Reserved

Parameter ID (0) (Advanced Information) 1/9

Description	Address (h) (Byte Mode)	Address (Bit)	Data (b/h)	Data (h)	Comment		
Block / Sector Erase sizes Identifies the erase granularity for all Flash Components	30h	00	01b	EDh	00 = reserved 01 = 4KB erase 10 = reserved 11 = 64KB erase		
		01					
Write Granularity		02	1b		0 = No, 1 = Yes		
Write Enable Instruction Required for Writing to Volatile Status Register		03	01b		00 = N/A 01 = use 50h opcode 11 = use 06h opcode		
Write Enable Opcode Select for Writing to Volatile Status Register		04					
Unused		05	111b		Reserved		
		06					
		07					
4 Kilo-Byte Erase Opcode		31h	08		20h	20h	4 KB Erase Support (FFh = not supported)
			09				
	10						
	11						
	12						
	13						
	14						
Supports (1-1-2) Fast Read Device supports single input opcode & address and dual output data Fast Read	32h	16	1b	F1h	0 = not supported 1 = supported		
		17	00b			00 = 3-Byte 01 = 3- or 4-Byte (e.g. defaults to 3-Byte mode; enters 4-Byte mode on command) 10 = 4-Byte 11 = reserved	
Address Byte Number of bytes used in addressing for flash array read, write and erase.		18					
		Supports Double Data Rate (DDR) Clocking Indicates the device supports some type of double transfer rate clocking.			19		0b
Supports (1-2-2) Fast Read Device supports single input opcode, dual input address, and dual output data Fast Read		20	1b		0 = not supported 1 = supported		
Supports (1-4-4) Fast Read Device supports single input opcode, quad input address, and quad output data Fast Read		21	1b		0 = not supported 1 = supported		
Supports (1-1-4) Fast Read Device supports single input opcode & address and quad output data Fast Read		22	1b		0 = not supported 1 = supported		
Unused		23	1b		Reserved		
Unused		33h	24		FFh	FFh	Reserved
			25				
	26						
	27						
	28						
	29						
	30						
31							

Parameter ID (0) (Advanced Information) 2/9

Description	Address (h) (Byte Mode)	Address (Bit)	Data (h)	Comment
Flash Memory Density	37h : 34h	31 : 00	00FFFFFFh	16 Mbits

Parameter ID (0) (Advanced Information) 3/9

Description	Address (h) (Byte Mode)	Address (Bit)	Data (b/h)	Data (h)	Comment
(1-4-4) Fast Read Number of Wait states (dummy clocks) needed before valid output	38h	00	00100b	44h	4 dummy clocks
		01			
		02			
		03			
		04			
Quad Input Address Quad Output (1-4-4) Fast Read Number of Mode Bits	38h	05	010b	44h	8 mode bits
		06			
		07			
(1-4-4) Fast Read Opcode Opcode for single input opcode, quad input address, and quad output data Fast Read.	39h	08	EBh	EBh	
		09			
		10			
		11			
		12			
		13			
		14			
(1-1-4) Fast Read Number of Wait states (dummy clocks) needed before valid output	3Ah	16	01000b	08h	
		17			
		18			
		19			
		20			
(1-1-4) Fast Read Number of Mode Bits	3Ah	21	000b	08h	
		22			
		23			
(1-1-4) Fast Read Opcode Opcode for single input opcode & address and quad output data Fast Read.	3Bh	31 : 24	6Bh	6Bh	

Parameter ID (0) (Advanced Information) 4/9

Description	Address (h) (Byte Mode)	Address (Bit)	Data (b/h)	Data (h)	Comment
(1-1-2) Fast Read Number of Wait states (dummy clocks) needed before valid output	3Ch	00	01000b	08h	8 dummy clocks
		01			
		02			
		03			
		04			
(1-1-2) Fast Read Number of Mode Bits	3Ch	05	000b	08h	Not Supported
		06			
		07			
(1-1-2) Fast Read Opcode Opcode for single input opcode & address and dual output data Fast Read.	3Dh	15 : 08	3Bh	3Bh	
(1-2-2) Fast Read Number of Wait states (dummy clocks) needed before valid output	3Eh	16	00100b	04h	4 dummy clocks
		17			
		18			
		19			
		20			
(1-2-2) Fast Read Number of Mode Bits	3Eh	21	000b	04h	Not Supported
		22			
		23			
(1-2-2) Fast Read Opcode Opcode for single input opcode, dual input address, and dual output data Fast Read.	3Fh	31 : 24	BBh	BBh	

Parameter ID (0) (Advanced Information) 5/9

Description	Address (h) (Byte Mode)	Address (Bit)	Data (b/h)	Data (h)	Comment	
Supports (2-2-2) Fast Read Device supports dual input opcode & address and dual output data Fast Read.	40h	00	0b	EEh	0 = not supported 1 = supported	
Reserved. These bits default to all 1's		01	111b		EEh	Reserved
		02				
		03				
Supports (4-4-4) Fast Read Device supports Quad input opcode & address and quad output data Fast Read.		04	0b		EEh	0 = not supported 1 = supported (EQPI Mode)
Reserved. These bits default to all 1's		05	111b		EEh	Reserved
		06				
	07					
Reserved. These bits default to all 1's	43h : 41h	31 : 08	FFh	FFh	Reserved	

Parameter ID (0) (Advanced Information) 6/9

Description	Address (h) (Byte Mode)	Address (Bit)	Data (b/h)	Data (h)	Comment
Reserved. These bits default to all 1's	45h : 44h	15 : 00	FFh	FFh	Reserved
(2-2-2) Fast Read Number of Wait states (dummy clocks) needed before valid output	46h	16	00000b	00h	Not Supported
		17			
		18			
		19			
		20			
(2-2-2) Fast Read Number of Mode Bits	46h	21	000b	00h	Not Supported
		22			
		23			
(2-2-2) Fast Read Opcode Opcode for dual input opcode & address and dual output data Fast Read.	47h	31 : 24	FFh	FFh	Not Supported

Parameter ID (0) (Advanced Information) 7/9

Description	Address (h) (Byte Mode)	Address (Bit)	Data (b/h)	Data (h)	Comment
Reserved. These bits default to all 1's	49h : 48h	15 : 00	FFh	FFh	Reserved
(4-4-4) Fast Read Number of Wait states (dummy clocks) needed before valid output	4Ah	16	00h	00h	Reserved
		17			
		18			
		19			
		20			
(4-4-4) Fast Read Number of Mode Bits	4Ah	21	000b	00h	Reserved
		22			
		23			
(4-4-4) Fast Read Opcode Opcode for quad input opcode/address, quad output data Fast Read.	4Bh	31 : 24	FFh	FFh	Reserved

Parameter ID (0) (Advanced Information) 8/9

Description	Address (h) (Byte Mode)	Address (Bit)	Data (h)	Comment
Sector Type 1 Size	4Ch	07 : 00	0Ch	4 KB
Sector Type 1 Opcode	4Dh	15 : 08	20h	
Sector Type 2 Size	4Eh	23 : 16	0Fh	32KB
Sector Type 2 Opcode	4Fh	31 : 24	52h	

Parameter ID (0) (Advanced Information) 9/9

Description	Address (h) (Byte Mode)	Address (Bit)	Data (h)	Comment
Sector Type 3 Size	50h	07 : 00	10h	64 KB
Sector Type 3 Opcode	51h	15 : 08	D8h	
Sector Type 4 Size	52h	23 : 16	00h	Not Supported
Sector Type 4 Opcode	53h	31 : 24	FFh	Not Supported

Read Unique ID Number (4Bh)

The Read Unique ID Number instruction accesses a factory-set read-only 128-bit number that is unique to each device. The ID number can be used in conjunction with user software methods to help prevent copying or cloning of a system. The Read Unique ID instruction is initiated by driving the CS# pin low and shifting the instruction code “4Bh” followed by a three bytes of addresses, 0x000000h, and one byte of dummy clocks. After which, the 128-bit ID is shifted out on the falling edge of CLK. (Read Unique ID Instruction Sequence Diagram figure)

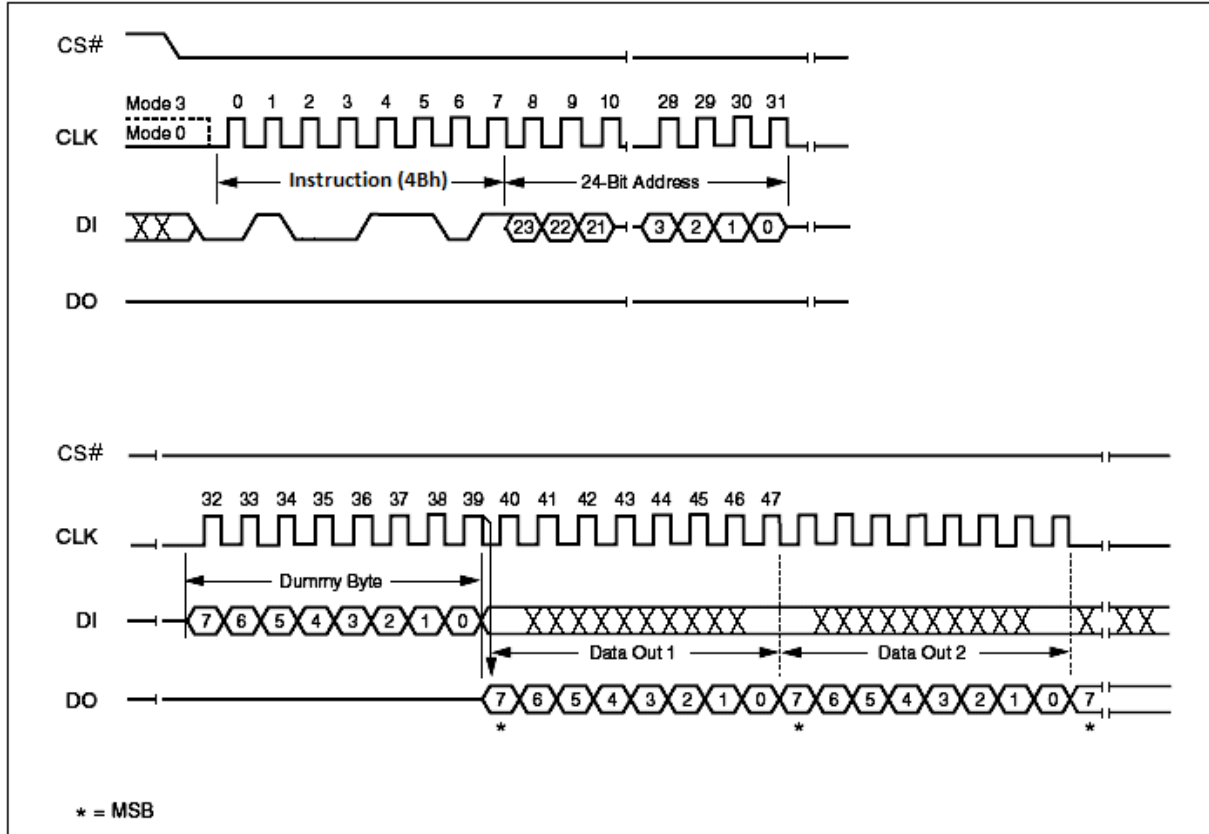
Read Unique ID Instruction Sequence Diagram

Power-up Timing

All functionalities and DC specifications are specified for a V_{CC} ramp rate of greater than 1V per 100 ms (0V to 1.65V in less than 270 ms). See Power-Up Timing table and Power-up Timing figure for more information.

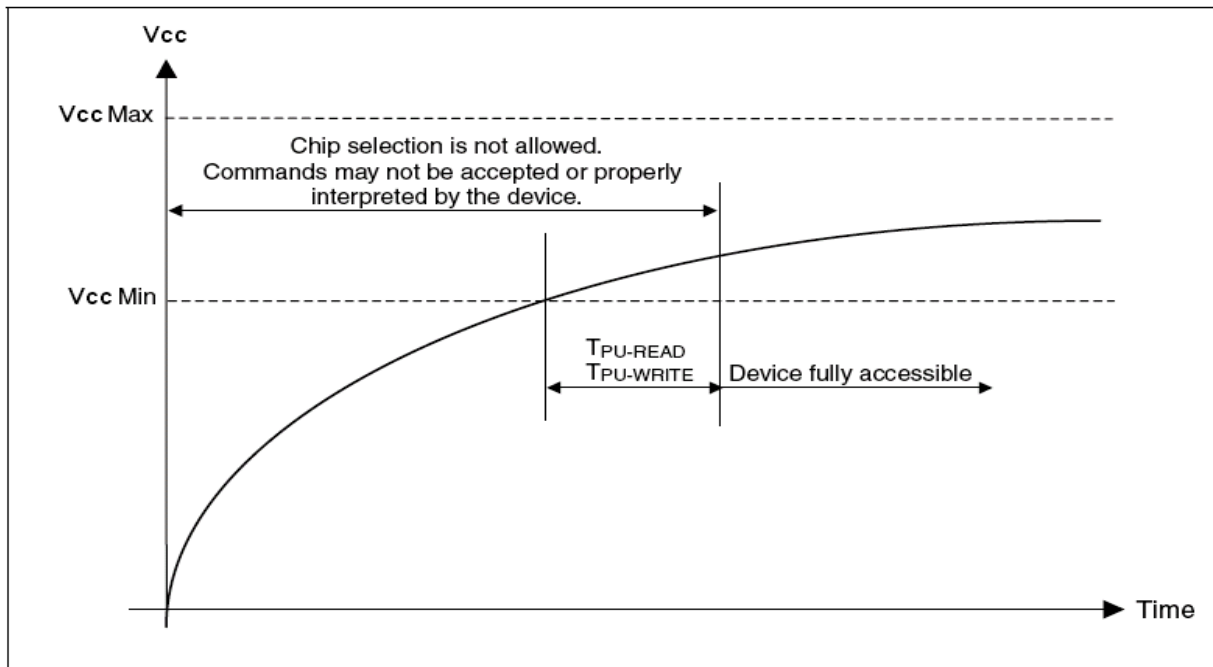

Power-up Timing

Power-Up Timing

Symbol	Parameter	Min.	Unit
$T_{PU-READ}^{*1}$	$V_{CC\ Min}$ to Read Operation	100	μs
$T_{PU-WRITE}^{*1}$	$V_{CC\ Min}$ to Write Operation	100	μs

Note:

1. This parameter is measured only for initial qualification and after a design or process change that could affect this parameter.

INITIAL DELIVERY STATE

The device is delivered with the memory array erased: all bits are set to 1 (each byte contains FFh). The Status Register contains 00h (all Status Register bits are 0) except SR3.2 (blank check bit) equals to 1.

DC Characteristics

($T_A = -40^{\circ}\text{C}$ to 85°C ; $V_{CC} = 1.65\text{-}3.6\text{V}$)

Symbol	Parameter	Test Conditions	Min.	Typ.	Max.	Unit
I_{LI}	Input Leakage Current		-	1	± 2	μA
I_{LO}	Output Leakage Current		-	1	± 2	μA
I_{CC1}	Standby Current	$CS\# = V_{CC}, V_{IN} = V_{SS}$ or V_{CC}	-	1	10	μA
I_{CC2}	Deep Power-down Current	$CS\# = V_{CC}, V_{IN} = V_{SS}$ or V_{CC}	-	1	10	μA
I_{CC3}	Operating Current (READ)	$CLK = 0.1 V_{CC} / 0.9 V_{CC}$ at 104 MHz, DQ = open	-	10	16	mA
		$CLK = 0.1 V_{CC} / 0.9 V_{CC}$ at 104 MHz for Quad Output Read, DQ = open	-	12	18	mA
I_{CC4}	Operating Current (PP)	$CS\# = V_{CC}$	-	-	25	mA
I_{CC5}	Operating Current (WRSR/WRSR3)	$CS\# = V_{CC}$	-	-	25	mA
I_{CC6}^{*1}	Operating Current (SE)	$CS\# = V_{CC}$	-	13	25	mA
I_{CC7}^{*1}	Operating Current (HBE/BE)	$CS\# = V_{CC}$	-	13	25	mA
V_{IL}	Input Low Voltage		-0.5	-	$0.2 V_{CC}$	V
V_{IH}	Input High Voltage		$0.7 V_{CC}$	-	$V_{CC}+0.4$	V
V_{OL}	Output Low Voltage	$I_{OL} = 100 \mu\text{A}, V_{CC} = V_{CC}$ Min.	-	-	0.3	V
V_{OH}	Output High Voltage	$I_{OH} = -100 \mu\text{A}, V_{CC} = V_{CC}$ Min.	$V_{CC}-0.2$	-	-	V

Note:

1. Erase current measure on all cells = '0' state.
2. Typical value of I_{CC3} @104 MHz at $T = 25^{\circ}\text{C}$, $V_{CC} = 3.3\text{V}$. Other typical values at $T = 25^{\circ}\text{C}$, $V_{CC} = 1.8\text{V}$.
3. Value guaranteed by design and/or characterization, not 100% tested in production.

AC Measurement Conditions

Symbol	Parameter	Min.	Max.	Unit
C_L	Load Capacitance	30		pF
	Input Rise and Fall Times	-	5	ns
	Input Pulse Voltages	0.2V _{CC} to 0.8V _{CC}		V
	Input Timing Reference Voltages	0.3V _{CC} to 0.7V _{CC}		V
	Output Timing Reference Voltages	V _{CC} / 2		V

AC Measurement I/O Waveform

AC Characteristics

 (T_A = -40°C to 85°C; V_{CC} = 1.65-3.6V)

Symbol	Alt	Parameter	Min	Typ	Max	Unit
F _R	f _c	Serial Clock Frequency for all commands, 0xBB-0xEB Read at DC=1, at V _{CC} = 2.3-3.6V	-	-	104	MHz
		Serial Clock Frequency for all commands, 0xBB-0xEB Read at DC=1, at V _{CC} = 1.65-2.3V	-	-	80	MHz
		Serial Clock Frequency for all commands, 0xBB-0xEB Read at DC=0, at V _{CC} = 1.65-3.6V	-	-	66	MHz
f _R		Serial Clock Frequency for READ	D.C.	-	50	MHz
t _{CH} ^{*1}		Serial Clock High Time for SDR	45% (1/F _c)	-	-	ns
t _{CL} ^{*1}		Serial Clock Low Time for SDR	45% (1/F _c)	-	-	ns
t _{CLCH} ^{*2}		Serial Clock Rise Time (Slew Rate)	0.2	-	-	V / ns
t _{CHCL} ^{*2}		Serial Clock Fall Time (Slew Rate)	0.2	-	-	V / ns
t _{SLCH}	t _{css}	CS# Active Setup Time	10	-	-	ns
t _{CHSH}		CS# Active Hold Time	10	-	-	ns
t _{SHCH}		CS# Not Active Setup Time	10	-	-	ns
t _{CHSL}		CS# Not Active Hold Time	10	-	-	ns
t _{SHSL}	t _{CSH}	CS# High Time	40	-	-	ns
t _{SHSL} ^{*2}	t _{CSH}	Volatile Register Write Time	50	-	-	ns
t _{SHQZ} ^{*2}	t _{DIS}	Output Disable Time	-	-	12	ns
t _{CLQX}	t _{HO}	Output Hold Time	1.2	-	-	ns
t _{DVCH}	t _{DSU}	Data In Setup Time	4	-	-	ns
t _{CHDX}	t _{DH}	Data In Hold Time	4	-	-	ns
t _{HLCH}		HOLD# Low Setup Time (relative to CLK)	5	-	-	ns
t _{HHCH}		HOLD# High Setup Time (relative to CLK)	5	-	-	ns
t _{CHHH}		HOLD# Low Hold Time (relative to CLK)	5	-	-	ns
t _{CHHL}		HOLD# High Hold Time (relative to CLK)	5	-	-	ns
t _{HLQZ} ^{*2}	t _{HZ}	HOLD# to Output High-Z	-	-	10	ns
t _{HHQX} ^{*2}	t _{LZ}	HOLD# to Output Low-Z	-	-	10	ns
t _{CLQV}	t _v	Output Valid from CLK	-	-	12	ns
t _{WHSL} ^{*3}		Write Protect Setup Time before CS# Low	20	-	-	ns
t _{SHWL} ^{*3}		Write Protect Hold Time after CS# High	100	-	-	ns
t _{DP} ^{*2}		CS# High to Deep Power-down Mode	-	-	3	μs
t _{RES1} ^{*2}		CS# High to Standby Mode without Electronic Signature read	-	-	30	μs
t _{RES2} ^{*2}		CS# High to Standby Mode with Electronic Signature read	-	-	30	μs

AC Characteristics-Continued

Symbol	Alt	Parameter	Min	Typ	Max	Unit	
t _W		Write Status Register Cycle Time	-	4	30	ms	
t _{PP}		Page Programming Time	-	1	4	ms	
t _{SE}		Sector Erase Time	-	0.1	0.5	s	
t _{HBE}		Half Block Erase Time	-	0.3	2	s	
t _{BE}		Block Erase Time	-	0.5	3	s	
t _{CE}		Chip Erase Time	-	15	35	s	
	t _{SR}	Software Reset Latency	WIP = write operation	-	-	28	μs
			WIP = not in write operation	-	-	0	μs

Note:

1. t_{CH} + t_{CL} must be greater than or equal to 1/ f_C.
2. Value guaranteed by characterization, not 100% tested in production.
3. Only applicable as a constraint for a Write status Register instruction when Status Register Protect Bit is set at 1.
4. Typical value at T=25°C.

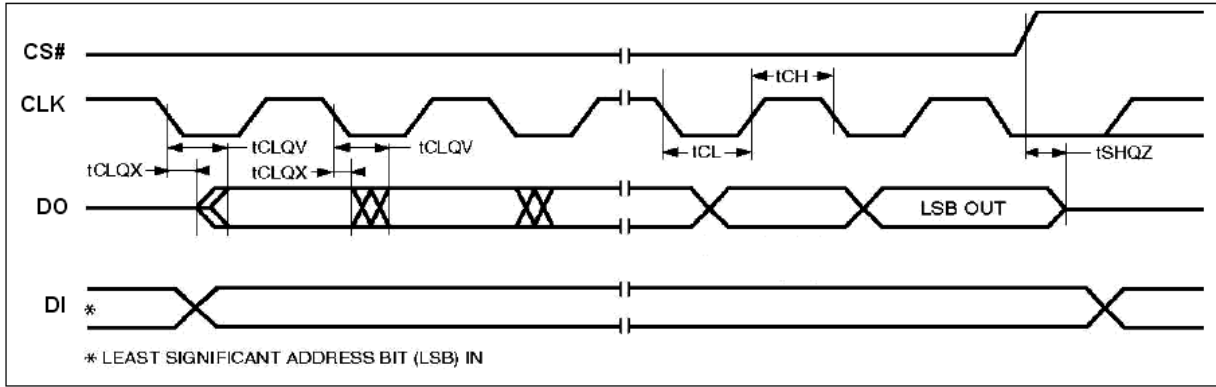
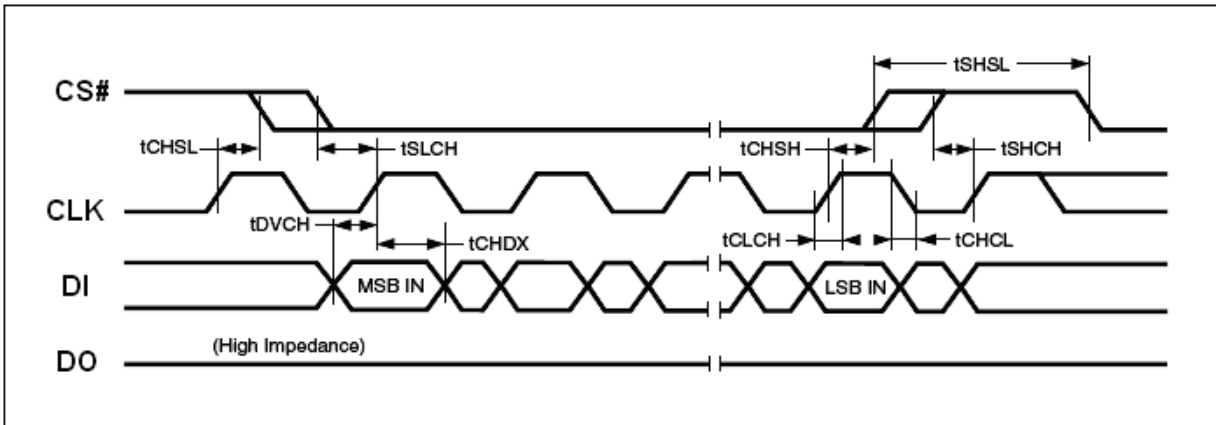
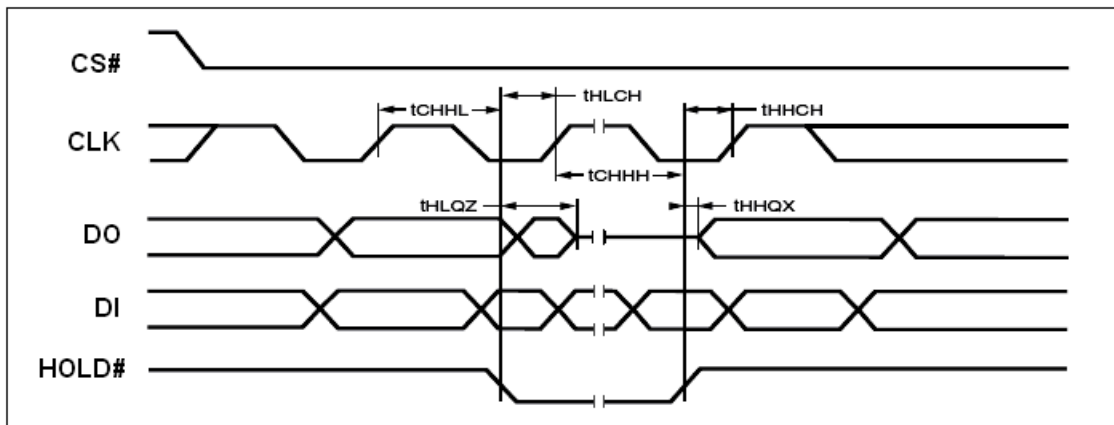
Serial Output Timing

Input Timing

Hold Timing

ABSOLUTE MAXIMUM RATINGS

Stresses above the values so mentioned above may cause permanent damage to the device. These values are for a stress rating only and do not imply that the device should be operated at conditions up to or above these values. Exposure of the device to the maximum rating values for extended periods of time may adversely affect the device reliability.

Parameter	Value	Unit
Storage Temperature	-65 to +150	°C
Output Short Circuit Current ^{*1}	200	mA
Input and Output Voltage (with respect to ground) ^{*2}	-0.5 to V _{CC} +0.5	V
V _{CC}	-0.5 to V _{CC} +0.5	V

Note:

1. No more than one output shorted at a time. Duration of the short circuit should not be greater than one second.
2. Minimum DC voltage on input or I/O pins is -0.5V. During voltage transitions, inputs may undershoot V_{SS} to -1.0V for periods of up to 50ns and to -2.0V for periods of up to 20ns. See figure below. Maximum DC voltage on output and I/O pins is V_{CC} + 0.5V. During voltage transitions, outputs may overshoot to V_{CC} + 1.5V for periods up to 20ns. See figure below.

RECOMMENDED OPERATING RANGES ^{*1}

Parameter	Value	Unit
Ambient Operating Temperature Industrial Devices	-40 to 85	°C
Operating Supply Voltage V _{CC}	Full: 1.65 to 3.6	V

Note:

1. Recommended Operating Ranges define those limits between which the functionality of the device is guaranteed.

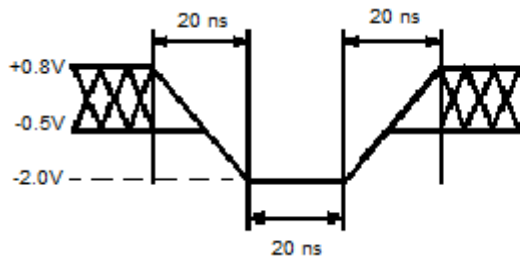

Maximum Negative Overshoot Waveform

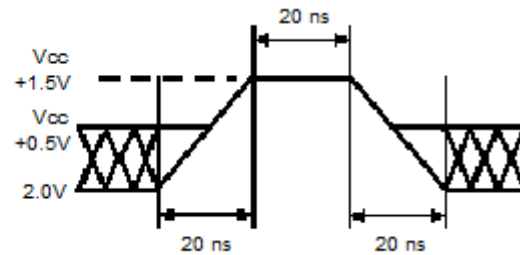

Maximum Positive Overshoot Waveform

CAPACITANCE $(V_{CC} = 1.65\text{-}3.6\text{V})$

Parameter Symbol	Parameter Description	Test Setup	Typ	Max	Unit
C_{IN}	Input Capacitance	$V_{IN} = 0$	-	6	pF
C_{OUT}	Output Capacitance	$V_{OUT} = 0$	-	8	pF

Note: Sampled only, not 100% tested, at $T_A = 25^\circ\text{C}$ and a frequency of 20MHz.

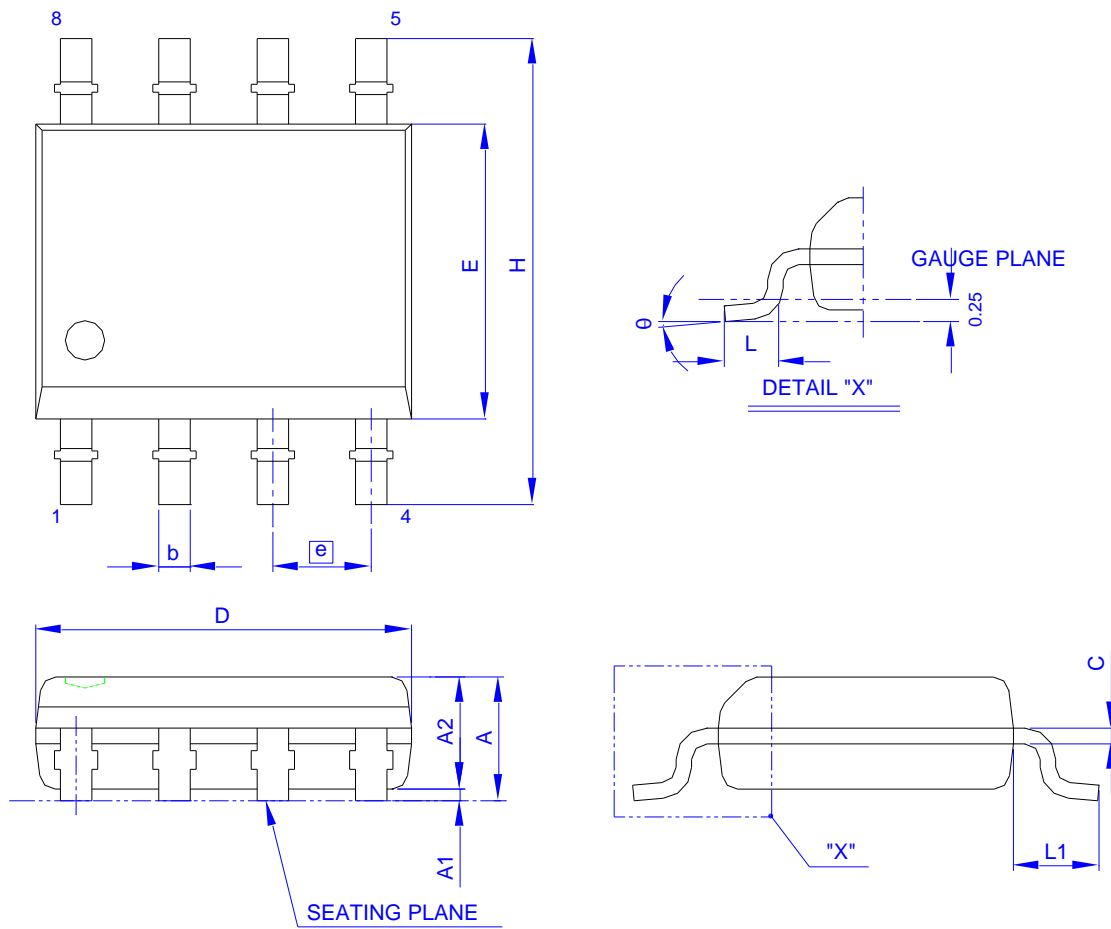
PACKAGE MECHANICAL
SOP 8 (150 mil)

Symbol	Dimension in mm			Dimension in inch			Symbol	Dimension in mm			Dimension in inch		
	Min	Norm	Max	Min	Norm	Max		Min	Norm	Max	Min	Norm	Max
A	1.35	1.60	1.75	0.053	0.063	0.069	D	4.80	4.90	5.00	0.189	0.193	0.197
A ₁	0.10	0.15	0.25	0.004	0.006	0.010	E	3.80	3.90	4.00	0.150	0.154	0.157
A ₂	1.25	1.45	1.55	0.049	0.057	0.061	L	0.40	0.66	0.86	0.016	0.026	0.034
b	0.33	0.406	0.51	0.013	0.016	0.020	e	1.27 BSC			0.050 BSC		
c	0.19	0.203	0.25	0.0075	0.008	0.010	L ₁	1.00	1.05	1.10	0.039	0.041	0.043
H	5.80	6.00	6.20	0.228	0.236	0.244	θ	0°	---	8°	0°	---	8°

Controlling dimension: millimeter

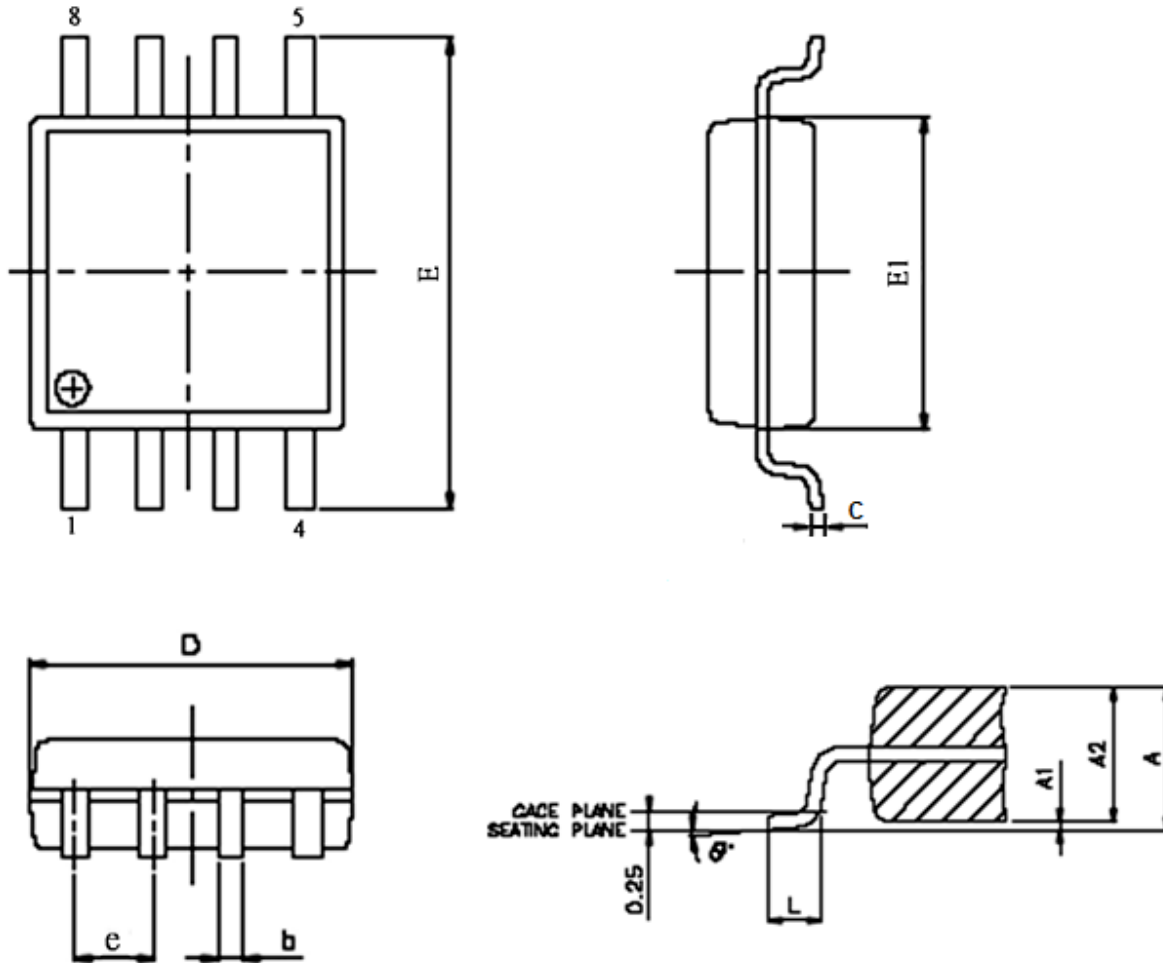
SOP 200 mil (official name = 208 mil)

SYMBOL	DIMENSION IN MM		
	MIN.	NOR	MAX
A	1.75	1.975	2.20
A1	0.05	0.15	0.25
A2	1.70	1.825	1.95
D	5.15	5.275	5.40
E	7.70	7.90	8.10
E1	5.15	5.275	5.40
e	---	1.27	---
b	0.35	0.425	0.50
C	0.19	0.200	0.25
L	0.5	0.65	0.80
θ	0°	4°	8°

- Note : 1. Coplanarity: 0.1 mm
 2. Max. allowable mold flash is 0.15 mm
 at the pkg ends, 0.25 mm between leads.

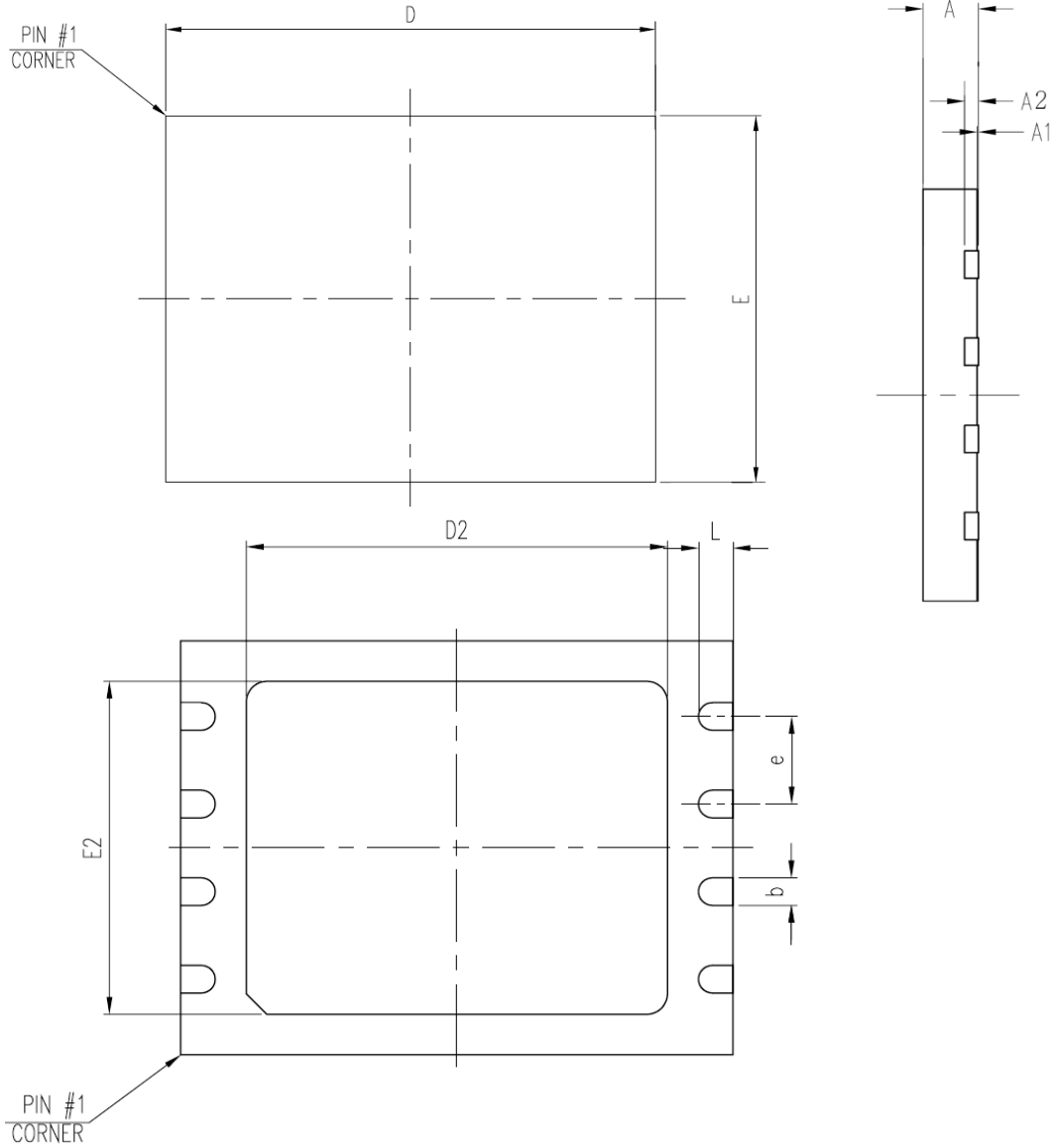
VDFN / WSON 8 (6x5 mm)

SYMBOL	DIMENSION IN MM		
	MIN.	NOR	MAX
A	0.70	0.75	0.80
A1	0.00	0.02	0.04
A2	---	0.20	---
D	5.90	6.00	6.10
E	4.90	5.00	5.10
D2	3.30	3.40	3.50
E2	3.90	4.00	4.10
e	---	1.27	---
b	0.35	0.40	0.45
L	0.55	0.60	0.65

Note: 1. Coplanarity: 0.1 mm

ORDERING INFORMATION

EN25QW16A - 104 H I P 2P

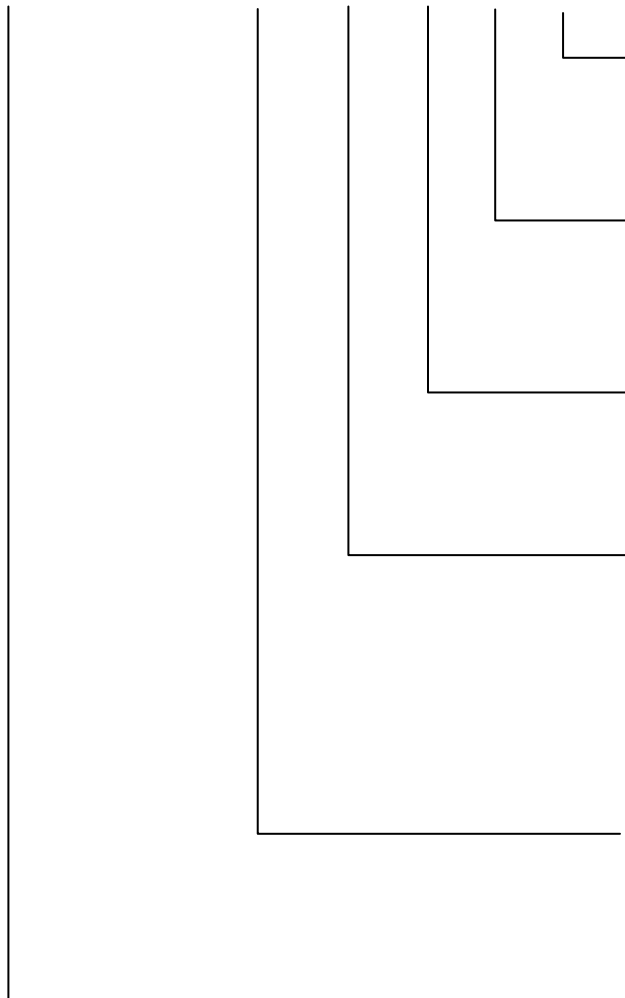

DIFFERENTIATION CODE

PACKAGING CONTENT

P = RoHS, Halogen-Free and REACH compliant

TEMPERATURE RANGE

I = Industrial (-40°C to +85°C)

PACKAGE

G = 8-pin 150 mil SOP

H = 8-pin 200 mil SOP

W = 8-contact VDFN / WSON (6x5 mm)

SPEED

104 = 104 MHz

BASE PART NUMBER

EN = Eon Silicon Solution Inc.

25QW = 1.65-3.6V Serial Flash with 4KB Uniform-Sector

16 = 16 Megabit (2048K x 8)

A = version identifier

Revisions List

Revision No	Description	Date
0.1	Initial Release	2022.03.17
0.2	Modify Chip Erase (CE) Address bits of Instruction Set (Erase Instruction) table	2022.05.09
1.0	<ol style="list-style-type: none"> 1. Delete Preliminary [in tail] 2. Modify Dummy configuration bit table 3. Modify the specification of ICC1, ICC2, ICC3, ICC7, tCE and suspend / resume time 4. Add VDFN / WSON 8 (6x5mm) package 	2022.08.11
1.1	<ol style="list-style-type: none"> 1. Modify the description of RDSR, RDSR2 and RDSR3 2. Modify EQPI Mode command 3. Correct Overshoot Waveform description 	2023.02.01
1.2	<ol style="list-style-type: none"> 1. Modify the memory organization 2. USON 3x2 and USON 4x3 removed 	2024.01.08

Important Notice

All rights reserved.

No part of this document may be reproduced or duplicated in any form or by any means without the prior permission of ESMT.

The contents contained in this document are believed to be accurate at the time of publication. ESMT assumes no responsibility for any error in this document, and reserves the right to change the products or specification in this document without notice.

The information contained herein is presented only as a guide or examples for the application of our products. No responsibility is assumed by ESMT for any infringement of patents, copyrights, or other intellectual property rights of third parties which may result from its use. No license, either express, implied or otherwise, is granted under any patents, copyrights or other intellectual property rights of ESMT or others.

Any semiconductor devices may have inherently a certain rate of failure. To minimize risks associated with customer's application, adequate design and operating safeguards against injury, damage, or loss from such failure, should be provided by the customer when making application designs.

ESMT's products are not authorized for use in critical applications such as, but not limited to, life support devices or system, where failure or abnormal operation may directly affect human lives or cause physical injury or property damage. If products described here are to be used for such kinds of application, purchaser must do its own quality assurance testing appropriate to such applications.